



# installation and start-up instructions

## HUMIDIFIERS AND HUMIDISTAT

# HUM

Cancels: II 912D-56-3

II HUM-56-1  
7-98

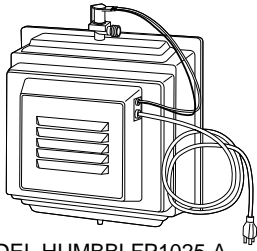

MODEL HUMBLFP1025-A--  
FAN-POWERED  
HUMIDIFIER

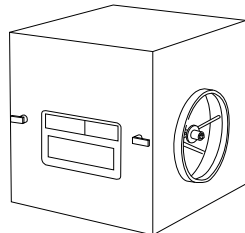

MODEL HUMBBWTR2019-A--  
WATER-SAVER  
BYPASS HUMIDIFIER

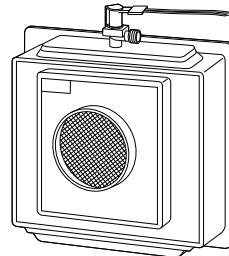

MODEL HUMBLBP2018-A--  
BYPASS HUMIDIFIER

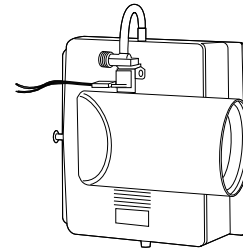

MODEL HUMBBSBP2017-A--

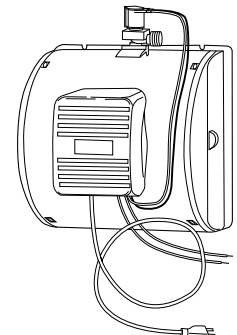

MODEL HUMBBSFP1016-A--  
FAN-POWERED  
HUMIDIFIER

A98361

### → Humidifiers

**NOTE:** Read the entire instruction in manual applicable to specific unit before starting the installation. This symbol → indicates a change since the last issue.

### SAFETY CONSIDERATIONS

Improper installation, adjustment, alteration, service, maintenance, or use can cause explosion, fire, electrical shock, or other conditions which may cause personal injury or property damage. Consult a qualified installer, service agency, distributor, or branch for information or assistance. The qualified installer or agency must use factory-authorized kits or accessories when modifying this product. Refer to the individual instructions packaged with the kits or accessories when installing.

Follow all safety codes. Wear safety glasses and work gloves. Use quenching cloth for brazing operations. Have fire extinguisher available. Read these instructions thoroughly and follow all warnings or cautions attached to the unit. Consult local building codes and National Electrical Code (NEC) for special requirements.

Recognize safety information. This is the safety-alert symbol ⚠. When you see this symbol on the unit and in instructions or manuals, be alert to the potential for personal injury.

Understand the signal words DANGER, WARNING, and CAUTION. These words are used with the safety-alert symbol. DANGER identifies the most serious hazards which **will** result in severe personal injury or death. WARNING signifies hazards which **could** result in personal injury or death. CAUTION is used to identify unsafe practices which **would** result in minor personal injury or product and property damage.

**WARNING:** Before installing or servicing system, always turn off main power to system. There may be more than 1 disconnect switch. Turn off accessory heater power if applicable. Electrical shock can cause personal injury or death.

**CAUTION:** Unit must not be installed where freezing temperatures could occur. Do not install unit on the furnace or fan coil jacket. Do not install unit where ends of cooling coil could restrict airflow to the humidifier. Condensation damage could occur if home has closed-off, unheated rooms.

### INSTALLATION OF HUMBLBP2018-A-- BYPASS HUMIDIFIER

Bryant's HUMBLBP2018-A-- bypass humidifier can be installed on either the supply or return plenum of a forced-air system. This unit requires an external bypass duct between the supply- and return-air ductwork.

It is recommended to install the humidifier where it can be easily serviced. If this humidifier is installed with a central cooling system the bypass duct must have a shutoff damper to close during the cooling season. Always install humidifier downstream of an electronic air cleaner.

## → I. INSPECT PACKAGE AND CHECK EQUIPMENT

Inspect contents of packaged humidifier. File claim with shipping company prior to installation if shipment is damaged or incomplete.

The package should contain:

1. Humidifier and media assembly
2. Humidistat
3. Template
4. Owner's Manual
5. Warranty Certificate
6. Solenoid valve with bridge rectifier
7. Saddle valve assembly with adapter
8. Four sheet metal screws
9. Foam tape
10. Water noise reducer (use for water pressure over 60 psi)
11. 6-in. damper
12. Worm clamp for field-supplied drain tube
13. Humidifier maintenance instruction sticker
14. Bryant logo label

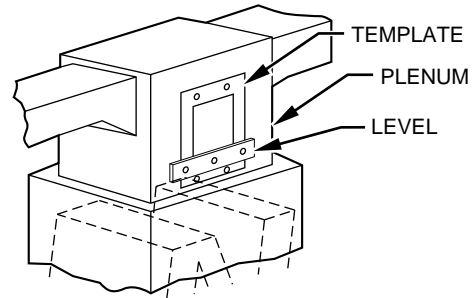
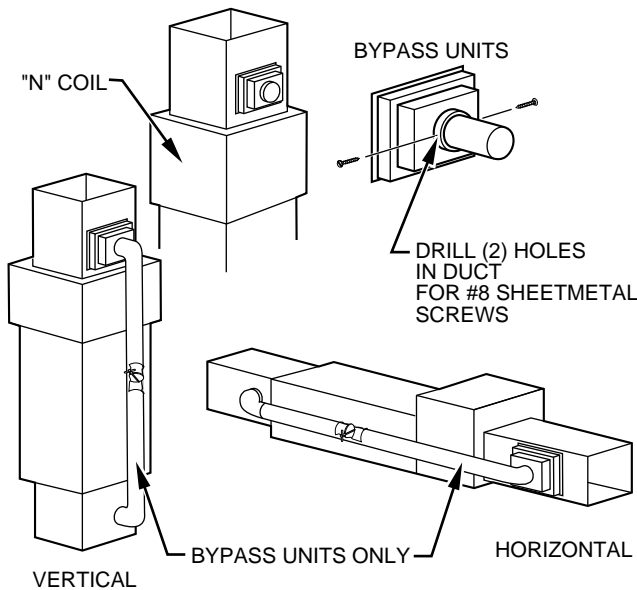

Fig. 2—Preparing Plenum Opening

A97096

**IMPORTANT:** For humidifier to operate properly it must be level and mounted on a vertical surface.

3. Drill four 1/8-in. holes in plenum.
4. Cut opening in plenum using heavy solid lines on template as a guide.



→ Fig. 1—Installation of HUMBBLBP2018-A-- Bypass-Type Humidifier

A98363

## II. SELECT LOCATION (SEE FIG. 1.)

Humidifier may be installed on either supply or return plenum. If furnace has air conditioning coil, be sure humidifier does not interfere with coil ends. Remember to provide clearance for maintenance and evaporator pad removal.

## III. PREPARE PLENUM OPENING (SEE FIG. 2.)

1. Use template for marking humidifier opening.
2. Tape in place on plenum making sure template is level.

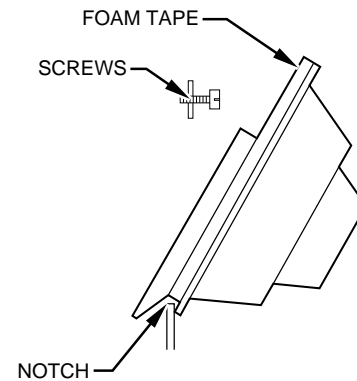

→ Fig. 3—Mounting the Humidifier

A98364

## IV. MOUNT THE HUMIDIFIER (SEE FIG. 3.)

1. Attach foam tape on inside of mounting flange.
2. Hook bottom notch of humidifier on opening cut in plenum.
3. Push top of humidifier to plenum aligning screw holes with flange.
4. Align, level, and secure using top screws first.
5. Insert bottom screws and tighten all screws for air tight seal.

## → V. INSTALL BYPASS DUCT

Attach field-supplied 6-in. diameter duct, elbow, or starting collar with field-supplied 1/4-in. zip screws. Install supplied 6-in. damper in 6-in. duct connector.

**IMPORTANT:** On systems with central cooling, the damper should be closed during cooling season to prevent bypass air.

**CAUTION:** Do not support weight of bypass duct from humidifier — damage could result.

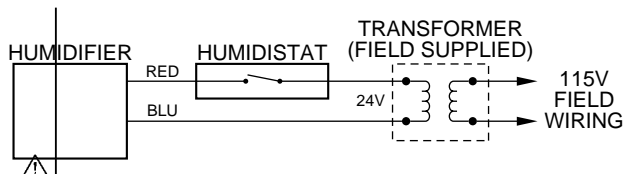
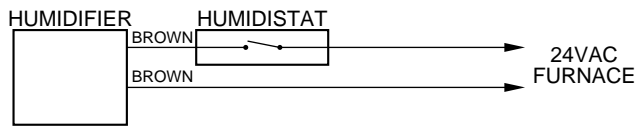

→ Fig. 4—Installation of Humidistat on Bypass-Type Humidifier

A98365

## VI. INSTALL DRAIN LINE

1. Use 1/2- or 5/8-in. vinyl tubing (field supplied) to connect drain on bottom of humidifier housing to an open drain.
- 2. Use supplied worm clamp to hold drain tubing in position over drain fitting outlet.

**CAUTION:** Unit may leak if drain tubing is misapplied. Do not insert tubing inside of drain fitting outlet.

3. Make sure line is free of traps due to sagging and has sufficient pitch to drain.

## VII. MAKE WATER CONNECTION

If garden hose is not used for water supply:

1. Mount saddle valve on water line according to instructions supplied with valve.
2. Run 1/4-in. diameter (water line grade) tubing from saddle valve to adapter on solenoid valve and tighten compression fittings.

**IMPORTANT:** If water pressure is higher than normal (60 psi), use noise suppression disk included in parts bag. (Read water noise reducer note located inside package for instructions.) For normal operation, saddle valve need only be opened 1 full turn to meet performance requirements.

3. Open valve and check installation for leaks.

**NOTE:** Saddle valve is self piercing on copper lines; 1/4-in. hole must be drilled in steel or iron pipes. Use only a grounded drill or a hand drill to avoid shock hazard. Turn off water and drain the pipe prior to drilling 1/4-in. hole.

## VIII. INSTALL HUMIDISTAT AND COMPLETE WIRING

1. Mount humidistat on inside wall, or return-air duct in accordance with section INSTALLATION OF HUMIDISTAT on page 10.
- 2. Wire brown low voltage leads to furnace control board, or install a field-supplied step-down transformer 115vac/24vac 60Hz to power solenoid valve. (See Fig. 4.) Make sure bridge rectifier is attached to coil of solenoid valve.

**NOTE:** Wiring must comply with National Electrical Code and any local codes or ordinances that may apply.

## IX. START-UP

1. Open saddle valve to permit water flow to the solenoid.
2. Check all connections for water leaks.
3. Set thermostat to call for heat. Set humidistat for highest humidity setting making sure contacts are closed. After a few minutes of operation, check the drain connection for leaks and to see if water is flowing through humidifier.
4. Reverse thermostat and humidistat settings to insure proper shutdown.
5. Reset thermostat to normal setting. Reset humidistat to recommended setting.

## X. FINAL STEPS

Attach humidifier maintenance instruction sticker to a visible location.

1. Inform homeowner of proper operation, maintenance, and humidistat setting.
  - a. If unit is installed during cooling season, close bypass damper, set humidistat for summer setting (OFF or lowest setting).
  - b. If installed during heating season, set unit for normal operation.

## INSTALLATION OF HUMBBLFP1025-A-- FAN POWERED HUMIDIFIER

Bryant's HUMBBLFP1025-A-- fan powered humidifier can only be installed on the supply plenum of a forced-air system. This unit requires an external 115-vac (fused) plug-in receptacle near the equipment for proper operation.

It is recommended to install the humidifier where it can be easily serviced. Pad access can be easily obtained from either the top or bottom of unit. Always install humidifier downstream of an electronic air cleaner.

## → I. INSPECT PACKAGE AND CHECK EQUIPMENT

Inspect the contents of packaged humidifier. File claim with shipping company prior to installation if shipment is damaged or incomplete.

The package should contain:

1. Humidifier and media assembly
2. Humidistat
3. Template
4. Owner's Manual
5. Warranty Certificate
6. Solenoid valve
7. Saddle valve assembly with adapter
8. Four sheet metal screws
9. Foam tape
10. Water noise reducer (use for water pressure over 60 psi)
11. Worm clamp for field-supplied drain tube
12. Humidifier maintenance instruction sticker
13. Bryant logo label

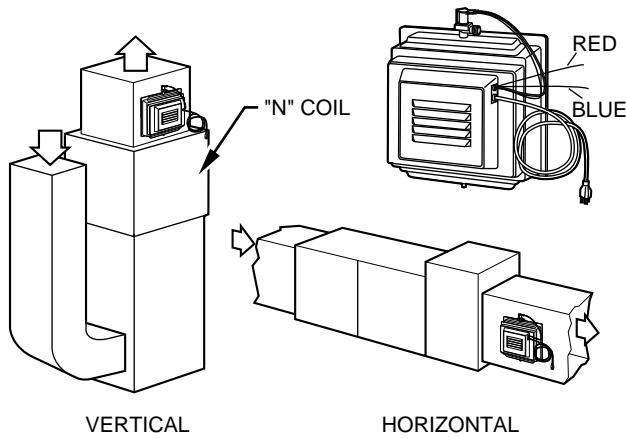

A98366

→ Fig. 5—Installation of HUMBLFP1025-A-- Fan-Type Humidifier

## II. SELECT LOCATION (SEE FIG. 5.)

Humidifier must be installed on supply plenum only. If furnace has air conditioning coil, be sure humidifier does not interfere with coil ends.

Remember to provide clearance for maintenance and evaporator pad removal. To access pad remove top or bottom cover to expose assembly (turn knob counter-clockwise).

## III. PREPARE PLENUM OPENING (SEE FIG. 2.)

1. Use template for marking humidifier opening.
2. Tape in place on plenum making sure template is level.

**IMPORTANT:** For humidifier to operate properly it must be level and mounted on a vertical surface.

3. Drill four 1/8-in. holes in plenum.
4. Cut opening in plenum using heavy solid lines on template as a guide.

## IV. MOUNT THE HUMIDIFIER (SEE FIG. 3.)

1. Attach foam tape on inside of mounting flange.
2. Hook bottom notch of humidifier on opening cut in plenum.
3. Push top of humidifier to plenum aligning screw holes with flange.
4. Align, level, and secure using top screws first.
5. Insert bottom screws and tighten all screws for air tight seal.

## → V. INSTALL DRAIN LINE

1. Use 1/2- or 5/8-in. vinyl tubing (field supplied) to connect drain on bottom of humidifier housing to an open drain.
2. Use supplied worm clamp to hold drain tubing in position over drain fitting outlet.

⚠	<b>CAUTION:</b> Unit may leak if drain tubing is misapplied. Do not insert tubing inside of drain fitting outlet.
---	---

3. Make sure line is free of traps due to sagging and has sufficient pitch to drain.

## VI. MAKE WATER CONNECTION

If garden hose is not used for water supply:

1. Mount saddle valve on water line according to instructions supplied with saddle valve.

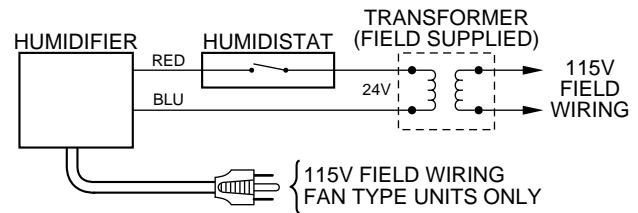
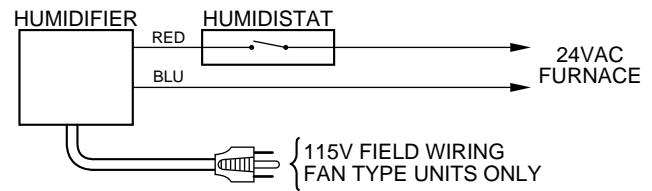

A96010

Fig. 6—Installation of Humidistat on Fan-Type Humidifier

2. Run 1/4-in. diameter (water line grade) tubing from saddle valve to adapter on solenoid valve and tighten compression fittings.

**IMPORTANT:** If water pressure is higher than normal (60 psi), use noise suppression disk included in parts bag. (Read water noise reducer note located inside package for instructions). For normal operation, saddle valve need only be opened 1 full turn to meet performance requirements.

3. Open valve and check installation for leaks.

**NOTE:** Saddle valve is self piercing on copper lines; 1/4-in. hole must be drilled in steel or iron pipes. Use only a grounded drill or a hand drill to avoid shock hazard. Turn off water and drain the pipe prior to drilling 1/4-in. hole.

## VII. INSTALL HUMIDISTAT AND COMPLETE WIRING

1. Mount humidistat on inside wall, or return-air duct in accordance with section INSTALLATION OF HUMIDISTAT on page 10.
2. Wire red and blue low voltage. (See Fig. 6.)
3. Plug power cord in to 115-vac 60Hz source.

**NOTE:** Wiring must comply with National Electrical Code and any local codes or ordinances that may apply.

## VIII. START-UP

1. Open saddle valve to permit water flow to the solenoid.
2. Check all connections for water leaks.
3. Set thermostat to call for heat. Set humidistat for highest humidity setting making sure contacts are closed. After a few minutes of operation, check the drain connection for leaks and to see if water is flowing through humidifier.
4. Reverse thermostat and humidistat settings to insure proper shutdown.
5. Reset thermostat to normal setting. Reset humidistat to recommended setting.

## IX. FINAL STEPS

Attach humidifier maintenance instruction sticker to a visible location.

1. Inform homeowner of proper operation, maintenance, and humidistat setting.
  - a. If unit is installed during cooling season set humidistat for summer setting (OFF or lowest setting).
  - b. If installed during heating season, set unit for normal operation.

## INSTALLATION OF HUMBBSFP1016-A-- FAN POWERED HUMIDIFIER

Bryant's HUMBBSFP1016-A-- fan powered humidifier can only be installed on the supply plenum of a forced-air system. This unit requires an external 115-vac (fused) plug-in receptacle near the equipment for proper operation.

It is recommended to install the humidifier where it can be easily serviced. Pad access door can be easily converted from right to the left hand side. Always install humidifier downstream of an electronic air cleaner.

### → I. INSPECT PACKAGE AND CHECK EQUIPMENT

Inspect contents of packaged humidifier. File claim with shipping company prior to installation, if shipment is damaged or incomplete.

The package should contain:

1. Humidifier and media assembly
2. Humidistat
3. Template
4. Owner's Manual
5. Warranty Certificate
6. Solenoid valve
7. Saddle valve assembly with adapter
8. Four sheet metal screws
9. Foam tape
10. Noise suppressor (use for water pressure over 60 psi)
11. Worm clamp for field-supplied drain tube
12. Humidifier maintenance instruction sticker
13. Bryant logo label

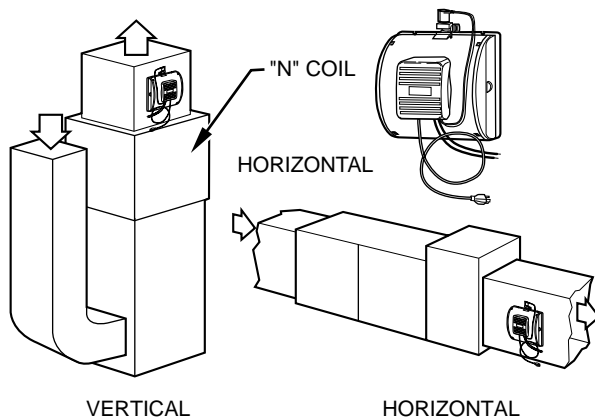

**Fig. 7—Installation of HUMBBSFP1016-A--  
Fan-Type Humidifier**

A97098

### II. SELECT LOCATION (SEE FIG. 7.)

Humidifier must be installed on supply plenum only. If furnace has air conditioning coil, be sure humidifier does not interfere with coil ends. Remember to provide clearance for maintenance and evaporator pad removal.

To reverse pad access from right to the left side:

1. Remove side door and media pad assembly.
2. Remove 4 screws and separate top assembly from lower mounting base. (See Fig. 8.)

3. Rotate lower mounting base 180 degrees, so side access door is now on left.
4. Snap together top assembly to mounting base and reinstall screws.
5. Replace media pad assembly (with distributor reservoir up) and side access door.

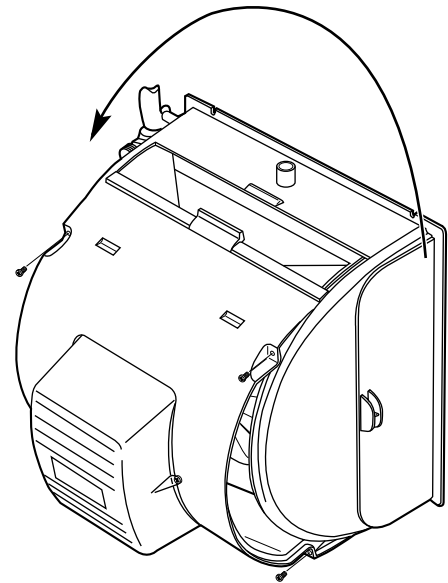
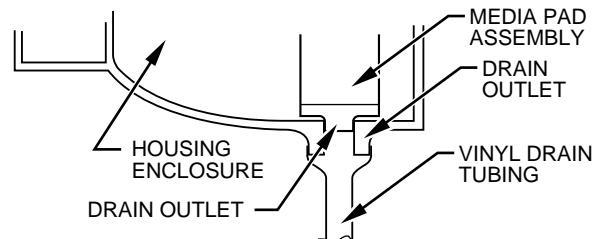

**Fig. 8—Reversing Door Access  
on HUMBBSFP1016-A--**

A96049

**CAUTION:** When re-installing media pad assembly into plastic housing, insure the assembly drain stub aligns into the drain outlet located in bottom of humidifier. Unit can leak if drain stub does not align with drain outlet. (See Fig. 9.)

**IMPORTANT:** Make sure front housing assembly with electrical cord is facing down.



**Fig. 9—Media Pad Assembly Installation**

A97108

### III. PREPARE PLENUM OPENING (SEE FIG. 2.)

1. Use template for marking humidifier opening.
2. Tape in place on plenum making sure template is level.

**IMPORTANT:** For humidifier to operate properly it must be level and mounted on a vertical surface.

3. Drill four 1/8-in. holes in plenum.
4. Cut opening in plenum using heavy solid lines on template as a guide.

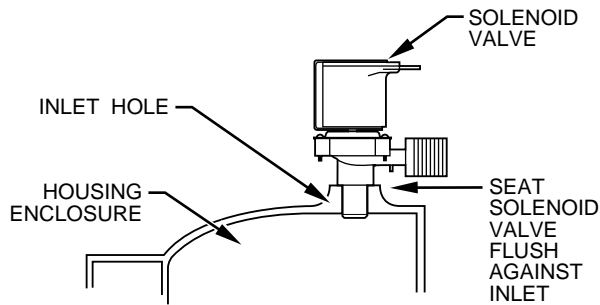

A97107

**Fig. 10—Top Mounting of Water Solenoid Valve**

#### IV. MOUNT THE HUMIDIFIER

1. Attach foam tape to back of mounting flange (exclude the off-set edge).
2. Hook off-set edge over opening cut in plenum.
3. Place humidifier in plenum aligning screw holes with flange.
4. Align, level, and tighten all screws for air tight seal.

#### V. INSTALL DRAIN LINE

1. Use 5/8-in. vinyl tubing (field supplied) to connect drain on bottom of humidifier housing to an open drain.
2. Use clamp to hold drain tubing in position over drain fitting outlet.

	<p><b>CAUTION:</b> Unit may leak if drain tubing is misapplied. Do not insert tubing inside of drain fitting outlet.</p>
--	--

3. Make sure line is free of traps due to sagging and has sufficient pitch to drain.

#### VI. MOUNT SOLENOID VALVE

The water solenoid valve should be mounted on top of humidifier enclosure.

1. To mount solenoid on top, see Fig. 10.
  - a. Firmly press valve into the top inlet hole on enclosure. Seat valve flush against inlet hole.
2. If alternate mounting of solenoid is required, see Fig. 11.
  - a. To mount solenoid on side, use 3/8-in. ID, 1/2-in. OD vinyl tubing (field supplied). Place tubing onto valve stem and secure with clamp.
  - b. Mount valve upside down securing to side of housing.
  - c. Place open end of tubing into the top inlet hole.

**IMPORTANT:** Be careful not to kink tubing.

#### VII. MAKE WATER CONNECTION

If garden hose is not used for water supply:

1. Mount saddle valve on water line according to instructions supplied with valve.
2. Run 1/4-in. diameter (water line grade) tubing from saddle valve to adapter on solenoid valve and tighten compression fittings.

**IMPORTANT:** If water pressure is higher than normal (60 psi), use noise suppression disk included in parts bag. (Read water noise reducer note located inside package for instructions). For normal operation, saddle valve need only be opened 1 full turn to meet performance requirements.

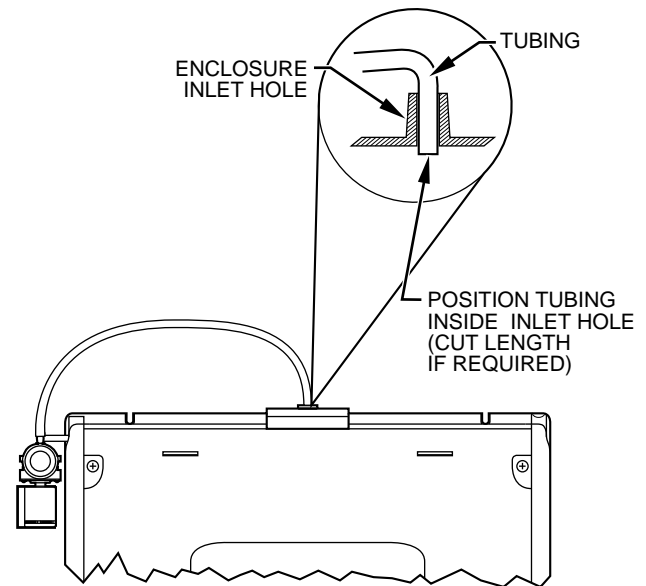

A97099

**Fig. 11—Alternate Mounting of Solenoid Valve on HUMBSFP1016-A-- Humidifier**

3. Open valve and check installation for leaks.

**NOTE:** Saddle valve is self piercing on copper lines; 1/4-in. hole must be drilled in steel or iron pipes. Use only a grounded drill or a hand drill to avoid shock hazard. Turn off water and drain the pipe prior to drilling 1/4-in. hole.

#### VIII. INSTALL HUMIDISTAT AND COMPLETE WIRING

1. Mount humidistat on inside wall, or return-air duct in accordance with section INSTALLATION OF HUMIDISTAT on page 10.
2. Wire red and blue low-voltage leads. (See Fig. 6.)
3. Plug power cord in to 115-vac 60Hz source.

**NOTE:** Wiring must comply with National Electrical Code and any local codes or ordinances that may apply.

#### IX. START-UP

1. Open saddle valve to permit water flow to the solenoid.
2. Check all connections for water leaks.
3. Set thermostat to call for heat. Set humidistat for highest humidity setting making sure contacts are closed. After a few minutes of operation, check the drain connection for leaks and to see if water is flowing through humidifier.
4. Reverse thermostat and humidistat settings to insure proper shutdown.
5. Reset thermostat to normal setting. Reset humidistat to recommended setting.

#### X. FINAL STEPS

Attach humidifier maintenance instruction sticker to a visible location.

1. Inform homeowner of proper operation, maintenance, and humidistat setting.
  - a. If unit is installed during cooling season set humidistat for summer setting (OFF or lowest setting).
  - b. If installed during heating season, set unit for normal operation.

## INSTALLATION OF HUMBBSP2017-A-- BYPASS HUMIDIFIER

Bryant's HUMBBSP2017-A-- bypass humidifier can be installed on either the supply or return plenum of a forced air system. This unit requires an external bypass duct between the supply- and return-air ductwork.

It is recommended to install the humidifier where it can be easily serviced. If this humidifier is installed with a central cooling system the bypass duct must have a shutoff damper to close during the cooling season. Always install humidifier downstream of an electronic air cleaner.

### → I. INSPECT PACKAGE AND CHECK EQUIPMENT

Inspect the contents of packaged humidifier. File claim with shipping company prior to installation if shipment is damaged or incomplete.

The package should contain:

1. Humidifier and media assembly
2. Humidistat
3. Template
4. 6-in. damper
5. Owner's Manual
6. Warranty Certificate
7. Solenoid valve with bridge rectifier
8. Transfer tube
9. Saddle valve assembly with adapter
10. Three pair of miscellaneous screws
11. Six sheet metal screws
12. Foam tape
13. Water noise reducer (use for water pressure over 60 psi)
14. Worm clamp for field-supplied drain tube
15. Humidifier maintenance instruction sticker
16. Bryant logo label

### II. SELECT LOCATION (SEE FIG. 12.)

Humidifier may be installed on either supply or return plenum. If furnace has air conditioning coil, be sure unit does not interfere with coil ends. Remember to provide clearance for maintenance and evaporator pad removal.

### III. PREPARE PLENUM OPENING (SEE FIG. 2.)

1. Use template for marking humidifier opening.
2. Tape in place on plenum making sure template is level.

**IMPORTANT:** For humidifier to operate properly it must be level and mounted on a vertical surface.

3. Drill four 1/8-in. holes in plenum.
4. Cut opening in plenum using heavy solid lines on template as a guide.

### IV. MOUNT HUMIDIFIER

1. Attach foam tape on inside of mounting flange.
2. Determine discharge direction.
3. If right-hand discharge is required:
  - a. Remove side door and media pad assembly.

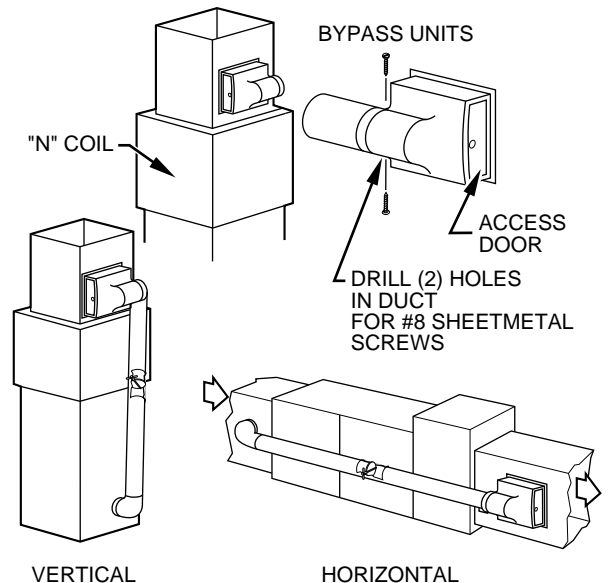

→ Fig. 12—Installation of HUMBBSP2017-A--  
Bypass-Type Humidifier

A98367

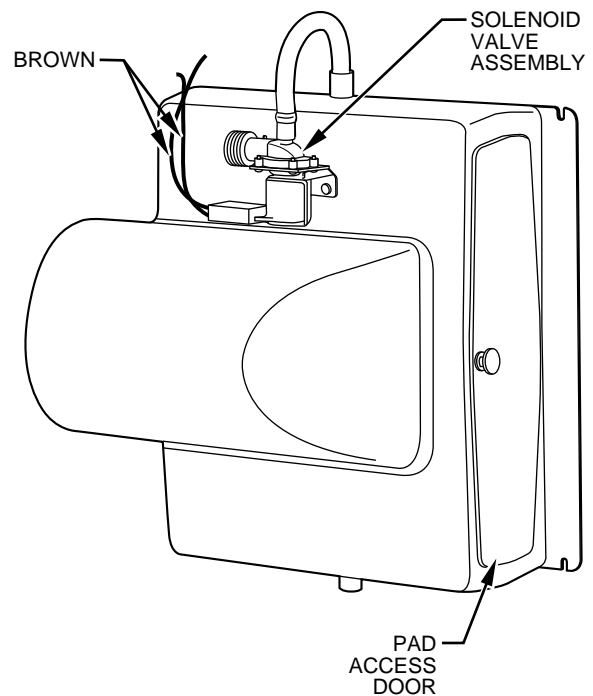

→ Fig. 13—Mounting Solenoid Valve  
on HUMBBSP2017-A-- Humidifier

A98368

- b. Invert unit 180 degrees.
- c. Re-install media pad and door.

**IMPORTANT:** Always ensure pad assembly is in the upright position.

4. Attach solenoid valve to unit housing using two screws in upper mounting holes. (See Fig. 13.) Do not over tighten screws.

5. Attach transfer tube to solenoid valve and insert free end into inlet fitting on top of unit housing.
6. Attach bridge rectifier to solenoid valve.
7. Insert sheet metal screws into lower holes in plenum, pre-drilled using template.
8. Tighten screws until heads protrude approximately 3/16-in.
9. Hang humidifier on bottom screws and push top of humidifier to plenum, aligning top screw holes with flange, and insert screws.
10. Align and level unit.
11. Tighten all screws for air tight seal.

#### → V. INSTALL BYPASS DUCT

Attach field-supplied 6-in. diameter duct, elbow, or starting collar with field-supplied 1/4-in. zip screws. Install supplied 6-in. damper in 6-in. duct connector.

**IMPORTANT:** On systems with central cooling, the damper should be closed during cooling season to prevent bypass air.

 **CAUTION:** Do not support weight of bypass duct from humidifier — damage could result.

#### VI. INSTALL DRAIN LINE

1. Use 5/8-in. ID vinyl tubing (field supplied) to connect drain on bottom of humidifier housing to an open drain.
- 2. Use worm clamp to hold drain tubing in position over drain fitting outlet.

 **CAUTION:** Unit may leak if drain tubing is misapplied. Do not insert tubing inside of drain fitting outlet.

3. Make sure line is free of traps due to sagging and has sufficient pitch to drain.

#### VII. MAKE WATER CONNECTION

If garden hose is not used for water supply:

1. Mount saddle valve on water line according to instructions supplied with valve.
2. Run 1/4-in. diameter (water line grade) tubing from saddle valve to adapter on solenoid valve and tighten compression fittings.

**IMPORTANT:** If water pressure is higher than normal (60 psi), use noise suppression disk included in parts bag. (Read water noise reducer note located inside package for instructions). For normal operation, saddle valve need only be opened 1 full turn to meet performance requirements.

3. Open valve and check installation for leaks.

**NOTE:** Saddle valve is self piercing on copper lines; 1/4-in. hole must be drilled in steel or iron pipes. Use only a grounded drill or a hand drill to avoid shock hazard. Turn off water and drain the pipe prior to drilling 1/4-in. hole.

#### VIII. INSTALL HUMIDISTAT AND COMPLETE WIRING

1. Mount humidistat on inside wall, or return-air duct in accordance with section INSTALLATION OF HUMIDISTAT on page 10.

- 2. Wire brown low-voltage leads to furnace control board, or install a field-supplied step-down transformer 115vac/24vac 60Hz to power solenoid valve. (See Fig. 4.) Make sure bridge rectifier is attached to coil of solenoid valve.

**NOTE:** Wiring must comply with National Electrical Code and any local codes or ordinances that may apply.

#### IX. START-UP

1. Open saddle valve to permit water flow to the solenoid.
2. Check all connections for water leaks.
3. Set thermostat to call for heat. Set humidistat for highest humidity setting making sure contacts are closed. After a few minutes of operation, check the drain connection for leaks and to see if water is flowing through humidifier.
4. Reverse thermostat and humidistat settings to insure proper shutdown.
5. Reset thermostat to normal setting. Reset humidistat to recommended setting.

#### X. FINAL STEPS

Attach humidifier maintenance instruction sticker to a visible location.

1. Inform homeowner of proper operation, maintenance, and humidistat setting.
  - a. If unit is installed during cooling season, close bypass damper, set humidistat for summer setting (OFF or lowest setting).
  - b. If installed during heating season, set unit for normal operation.

#### INSTALLATION OF HUMBBWTR2019-A-- BYPASS WATER SAVER HUMIDIFIER

Bryant's HUMBBWTR2019-A-- bypass water saver humidifier can be installed on either the supply or return plenum of a forced-air system. This unit requires an external bypass duct between the supply- and return-air ductwork.

- It is recommended to install the humidifier where it can be easily serviced. If this humidifier is installed with a central cooling system the factory-supplied 6-in. shutoff damper must be installed to close during the cooling season to prevent bypass air. Always install humidifier downstream of an electronic air cleaner.

#### → I. INSPECT PACKAGE AND CHECK EQUIPMENT

Inspect contents of packaged humidifier. File claim with shipping company prior to installation if shipment is damaged or incomplete.

The package should contain:

1. Humidifier and media assembly
2. Humidistat
3. Template
4. Ten ft 1/4-in. water supply tubing
5. Owner's Manual
6. Warranty Certificate
7. Support Bracket
8. One 1/4-in. blunt point screw
9. Saddle valve assembly
10. Four sheet metal screws
11. 6-in. damper
12. Worm clamp for field-supplied drain tube
13. Humidifier maintenance instruction sticker
14. Bryant logo label



## II. SELECT LOCATION (SEE FIG. 14.)

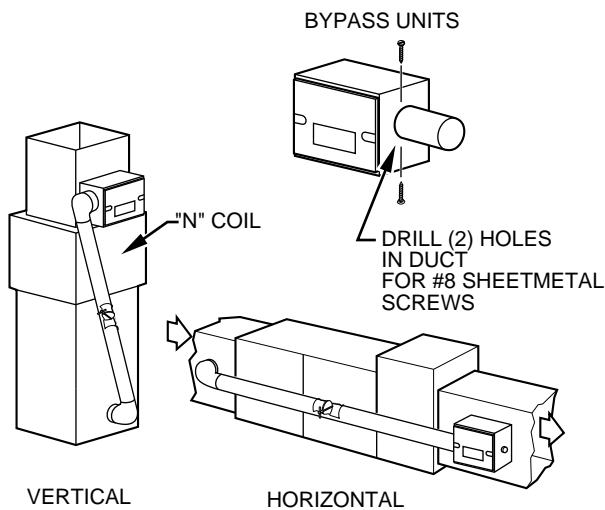

A98369

→ Fig. 14—Installation of HUMBWTR2019-A--  
Water Saver Humidifier

Humidifier may be installed on either supply or return plenum. If furnace has air conditioning coil, be sure humidifier does not interfere with coil ends. Remember to provide clearance for maintenance and evaporator pad removal.

## III. PREPARE PLENUM OPENING (SEE FIG. 2.)

1. Use template for marking humidifier opening.
2. Tape in place on plenum making sure template is level.

**IMPORTANT:** For humidifier to operate properly it must be level and mounted on a vertical surface.

3. Drill four 1/8-in. holes in plenum.
4. Cut opening in plenum using heavy solid lines on template as a guide.

## IV. MOUNT THE HUMIDIFIER

Supply or return plenum mounting:

1. Remove unit access door by turning 2 pawl latches 1/2 turn and pulling door forward.
2. Determine whether unit is to be used for right- or left-hand installation and apply gasket tape (supplied) to unit flange intended to seat against duct.
3. Remove media assembly from cabinet by lifting bearing end of assembly out of bearing retainer and pulling assembly toward outlet duct, thus disengaging media from motor. Remove media through unit access opening.
4. Remove pin from float assembly and remove float and arm. Remove drain plug and water pan.

**NOTE:** Water pan must be tilted for removal.

5. Mount unit to duct using pre-drilled holes and four 1/2-in. long screws found in parts bag.
- 6. Level unit and attach support bracket to unit using 1/4-in. blunt point screw. Attach other end of support bracket to duct by drilling a hole and using remaining 1/4-in. long screw.
7. Re-install water pan and drain plug. Re-attach float arm to valve body by aligning holes in both parts and re-inserting pin.

**NOTE:** Pin may be re-inserted from either direction.

8. Re-install media assembly. Ensure that square shaft of media assembly is located inside mating opening of motor coupling. Ensure that bearing washer is located on interior side of bearing retainer. (See Fig. 15.)

## → V. INSTALL BYPASS DUCT

Attach field-supplied 6-in. diameter duct, elbow, or starting collar with field-supplied 1/4-in. zip screws. Install supplied 6-in. damper in 6-in. duct connector.

**IMPORTANT:** On systems with central cooling, the damper should be closed during cooling season to prevent bypass air.

**CAUTION:** Do not support weight of duct from humidifier — damage could result.

## VI. INSTALL DRAIN LINE

1. Use 1/2-in. ID field-supplied vinyl tubing or equivalent tubing to connect overflow drain connection on unit water pan to drain. (See Fig. 16.)
2. Use worm clamp to hold tubing in position over overflow drain connection.

**IMPORTANT:** Make sure that line is free of traps due to sagging and has sufficient pitch to drain.

3. Unit must be level to provide proper drainage.

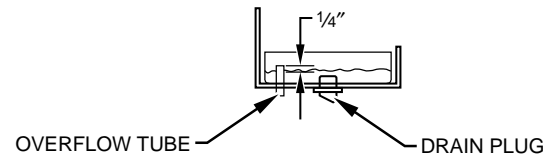

A96013

Fig. 16—Water Level in HUMBWTR2019-A--

## VII. MAKE WATER CONNECTION

1. Mount saddle valve on cold water line according to local codes.
2. For plastic tube installations: run 1/4-in. OD tubing (supplied) from saddle valve to float valve. Prepare tubing ends with plastic compression sleeves and brass inserts, and tighten compression fittings. Plastic compression nut supplied with float valve should not be torqued greater than 25 in.-lb. For copper tubing installations: copper tubing may be connected to float valve by using a field-supplied 1/4 to 1/4 in. straight-through compression union. Run copper tubing to 1 side of compression union and use a standard compression sleeve. Tighten compression nut to torque recommended by manufacturer. Attach approximately 6 in. of polyethylene supply tubing (supplied) between compression union and float valve. Prepare polyethylene tubing on both ends with brass inserts to prevent tubing collapse. Use compression nut at union to manufacturer's recommended torque, tighten plastic nut on float valve to maximum of 25 in.-lb.
3. Open valve and check installation for leaks.

**NOTE:** Valve is self piercing on copper lines; 1/4-in. hole must be drilled in steel or iron pipes. Use only a grounded drill or a hand drill to avoid shock hazard. Turn off water and drain the pipe prior to drilling 1/4-in. hole.

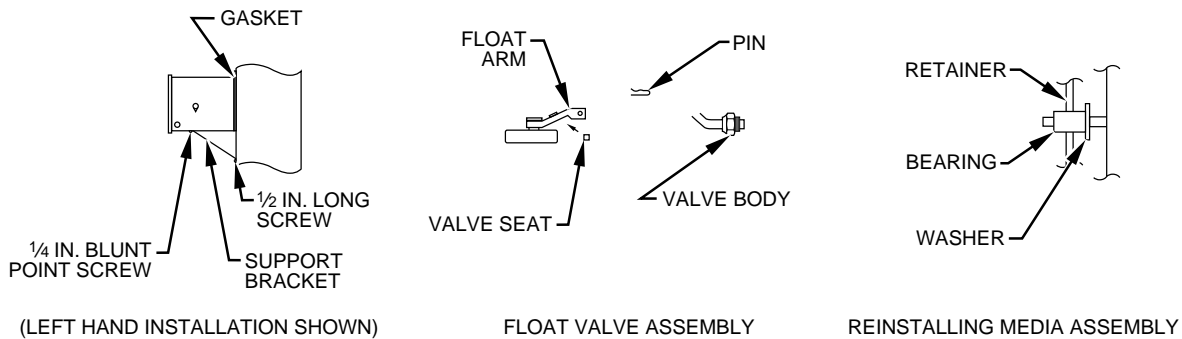

→ Fig. 15—Valve and Media Assembly for HUMBBWTR2019-A--

A98370

### VIII. INSTALL HUMIDISTAT AND COMPLETE WIRING

1. Mount humidistat on inside wall or return-air duct in accordance with section INSTALLATION OF HUMIDISTAT on page 10.

**NOTE:** Wiring must comply with national electrical code and any local codes or ordinances that may apply. (See Fig. 17.)

- b. If installed during heating season, set unit for normal operation.

### INSTALLATION OF HUMIDISTAT

The humidistat provides automatic control of humidifiers in central heating systems. It is designed for low voltage, wall, or surface duct mounting and contains a SPST snap-acting dustproof switch.

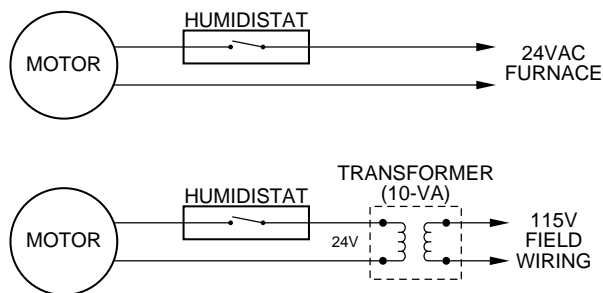

**CAUTION:** Disconnect power supply before making wiring connections to prevent possible electrical shock and equipment damage. Make wiring connections in accordance with Installation Instruction supplied with the humidifier.

1. Installer must be a trained, experienced service person.
2. Disconnect power supply before beginning installation.
3. Conduct a thorough checkout before leaving installation.

Fig.17—Humidistat Installation for HUMBBWTR2019-A--

A96014

### IX. START-UP

1. Open saddle valve to permit water to flow to the solenoid valve.
2. Check all connections for water leaks.
3. Set thermostat to call for heat. Set humidistat at highest humidity setting to be sure the contacts are closed. After a few minutes of operation, check the drain connection for leaks and to see if water is flowing through humidifier.
4. Reverse thermostat and humidistat settings to insure proper shutdown.
5. Reset thermostat to normal setting. Reset humidistat to recommended setting.

### X. FINAL STEPS

Attach humidifier maintenance instruction sticker to a visible location.

1. Inform homeowner of proper operation, maintenance, and humidistat setting.
  - a. If unit is installed during cooling season, close bypass damper, set humidistat for summer setting (OFF or lowest setting).

### I. WALL MOUNTING (LOW VOLTAGE)

1. Choose a location for humidistat about 5 ft above floor on inside wall with average room temperature and relative humidity conditions. Maximum ambient temperature of selected location must not exceed 125°F. Humidistat may be mounted directly on wall.
2. Drill a small hole in wall and run low-voltage wiring to location chosen. Pull about 6 in. of wire through hole. Plug opening to prevent drafts from affecting humidistat operation.
3. Remove knob, faceplate, and switch assembly from case by following steps listed below.
  - a. Remove knob by pulling away from casing. (See Fig. 18.)
  - b. Lift off faceplate, starting at right side. Left end of faceplate protrudes under lip of casing. (See Fig. 18.)
  - c. Remove switch by removing 2 screws in back of casing. Pressing tab on case. Lift out control. (See Fig. 19.)
4. Make connections to screw terminals on switch assembly. Re-install switch into casing — secure with 2 short screws.
5. Mount case horizontally over wires directly to wall using 2 long screws provided.
6. Replace faceplate and knob.

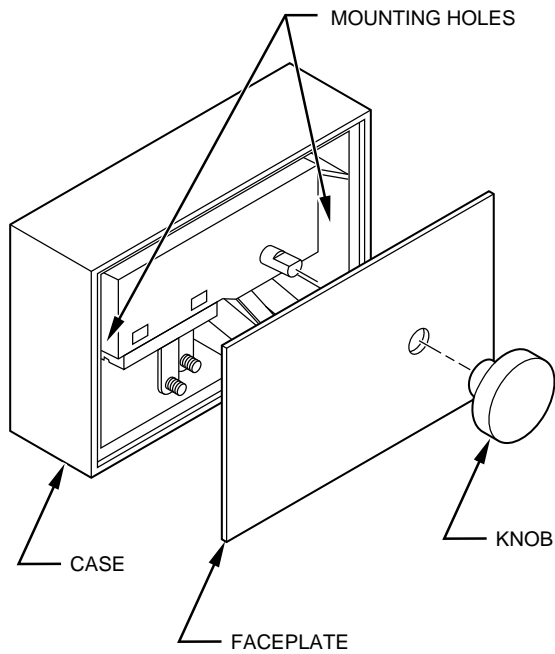

A97102

Fig. 18—Knob and Faceplate Removal

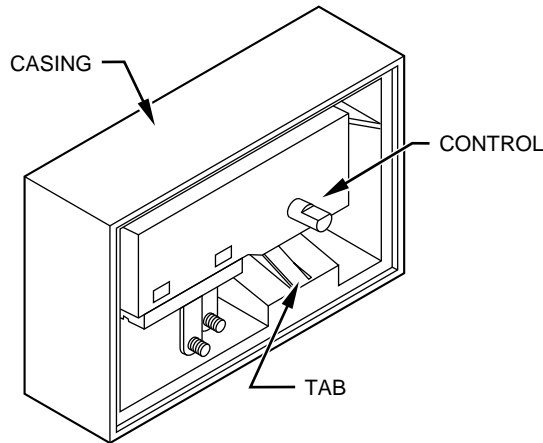

A97103

Fig. 19—Switch Assembly Removal

## II. DUCT MOUNTING (LOW VOLTAGE)

1. Locate humidistat at least 8 in. upstream of humidifier in return-air duct. If mounting near elbow area, keep device 6 in. upstream of elbow so element will be affected by normal airflow. (See Fig. 20.)

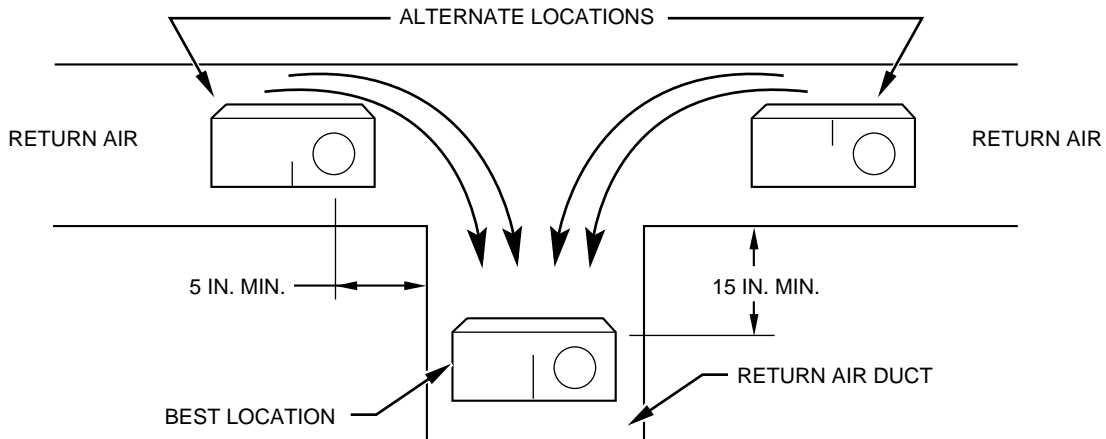

Fig. 20—Alternate Location Duct Mount Installation

2. Remove protective backing from template furnished with each control and apply self-adhesive side on return air duct at selected location. Following instructions on template and in Fig. 21, drill 2 mounting holes and six 1/4-in. diameter sensing holes in duct. Sensing holes allow return air to reach nylon sensing element and operate humidistat.

**NOTE:** If desired, cut square hole in duct as indicated on template as an alternative to holes.

3. Remove protective backing from foam gasket provided with control and apply to template.
4. Run low-voltage wire from humidifier to template. Lay wire over 1 side of foam gasket. Wire can enter humidistat case from any direction.

**IMPORTANT:** Do not position wire directly under standoff projections at back of case. If wire is under these projections, case will not seat tightly against gasket causing air leakage and possible improper operation.

5. Remove knob, faceplate, and switch assembly from case by following steps listed below.
  - a. Remove knob by pulling away from casing. (See Fig. 18.)
  - b. Lift off faceplate, starting at right side. Left end of faceplate protrudes under lip on casing. (See Fig. 18.)
  - c. Remove switch by removing 2 screws in back of casing. Pressing tab on case. Lift out control. (See Fig. 19.)
6. Make connections to screw terminals on switch assembly. Re-install switch into casing — secure with 2 short screws.
7. While holding wire in place. Mount humidistat case horizontally on duct using 2 mounting screws provided. Tighten firmly so that gasket seals space around wires and between case and duct. (See Fig. 21.)
8. Replace faceplate and knob.

## III. WIRING

All wiring must comply with local codes and ordinances.

## IV. ADJUSTMENT

Recommended humidistat setting should only be used as a guide. After adjustment of setting, allow at least 5 hr for equilibrium to be reached. Condensation on single pane windows or woodwork indicates excessive moisture. Condensation must not be allowed to continue for extended periods of time, or moisture damage can result. Lower humidistat setting in small steps until condensation disappears. However, if air is too dry, raise the setting.

A97104

**MAKE OPENING IN DUCT**

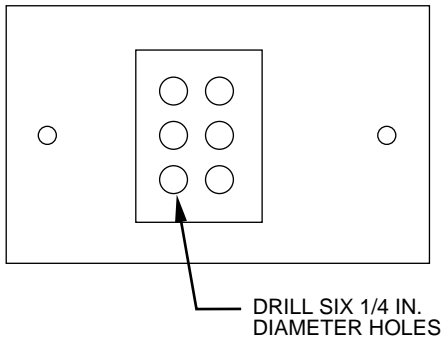

**MOUNT HUMIDISTAT CASE**

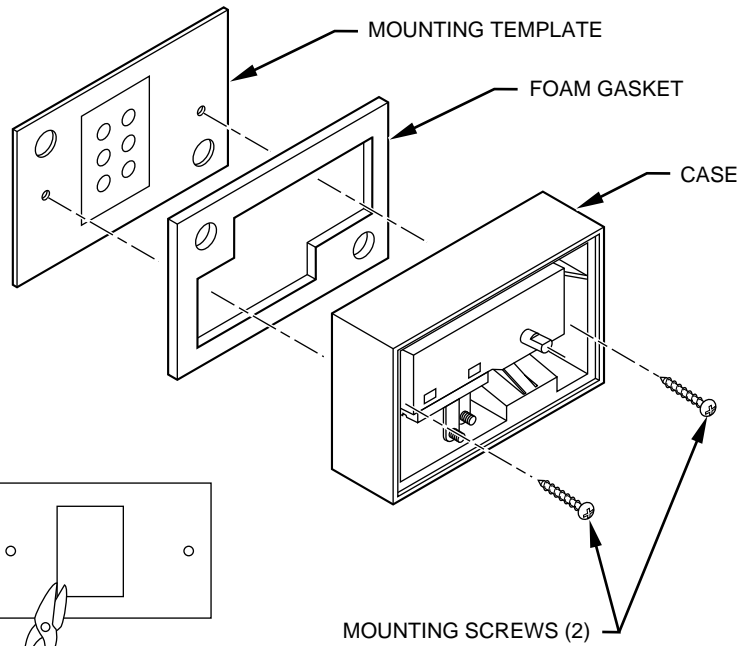

**ALTERNATE PROCEDURE:**

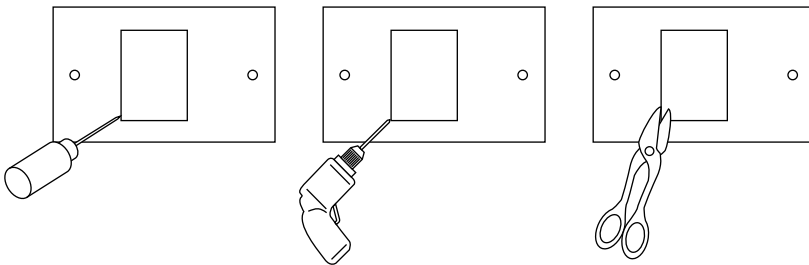

A97105

**Fig. 21—Humidistat Installation Schematic**

**V. OPERATION**

When relative humidity falls to humidistat set point, the humidistat switch makes contact and starts humidifier. In some central unit humidifier systems, furnace fan must be operating before humidifier will start. An increase in relative humidity above set point will stop humidifier.

**VI. CHECKOUT**

Place system in operation and observe at least 1 complete cycle to make certain that all components are functioning properly.

**RECOMMENDED HUMIDISTAT SETTING**

OUTSIDE TEMPERATURES	RECOMMENDED HUMIDISTAT SETTING
-20°F	15%
-10°F	20% (LO)
0°F	25%
+10°F	30%
+20°F	35%
+30°F	40% (MED)