



# INDUSTRIAL DIRECT AND INDIRECT/DIRECT EVAPORATIVE COOLING

Engineer designed to satisfy your design requirements.

## Modular Components

- Air Handling Modules in side, down or up discharge and single or dual inlet design.
- Evaporative Media Modules with standard 8" or Hi-Performance 12" media.
- Indirect Cooling Modules for added cooling with no moisture added (optional).

## Durable Construction

- Galvanized steel with our exclusive POLYBOND® polyester epoxy powder based coating ensures years of dependable service.

## Efficiency

- Choice of media modules allows cooling efficiencies tailored to your design requirements.

## Cost Effectiveness

- Competitive first cost combined with substantial energy savings over refrigerated air units results in quick payback. Plus, the simplicity of design allows low maintenance requirements.

## Other Features

- Precision balanced blower wheel.
- Solid shaft for rugged durability.
- AdobeAir motors and pumps are U.L. Recognized.
- City of Los Angeles (C.O.L.A.) approved.
- AMCA Licensed ratings
- U.L. Classified
- U.L. Listed



### Dual Inlet

Models MD628, MS628, and MU628  
Shown with 12" media modules DM120

U.L. Classified

Models UD980 and US980  
Shown with 12" media modules UM120

U.L. Listed

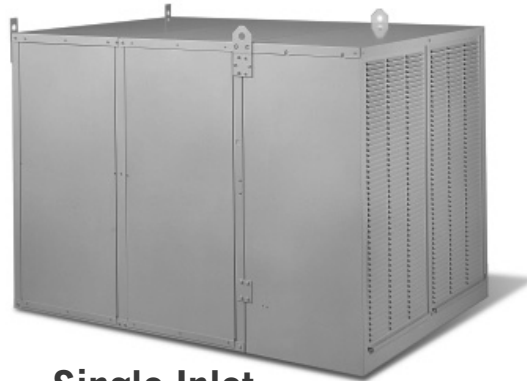

### Single Inlet

Models MD524 and MS524  
Shown with 12" media modules DM080

U.L. Classified

Models UD960 and US960  
Shown with 12" media modules UM080

U.L. Listed



AdobeAir, Inc. certifies that the evaporative air cooling products shown herein are licensed to bear the AMCA Seal. The ratings shown are based on tests and procedures performed in accordance with AMCA Publication 211 and comply with the requirements of the AMCA Certified Ratings Program.



# SINGLE-STAGE INDUSTRIAL EVAPORATIVE COOLING

## Direct Evaporative Cooling Process

Direct evaporative cooling exchanges sensible heat for latent heat, and follows upward along a constant wet-bulb temperature line on the Psychrometric Chart. The result is a dry-bulb temperature of the leaving air (B) approaching the wet-bulb temperature of the entering air (A).

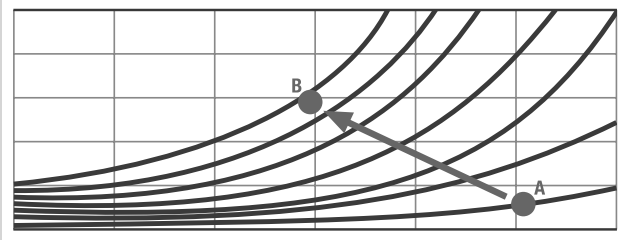

## Standard and Hi-Performance Models

The flexibility of modular components allows selection of CFM and saturation efficiencies producing the sensible heat capacities needed to meet design requirements. For many applications, our standard 8" media continues to be an economical choice, with an 80% saturation efficiency at 450 FPM. For more demanding design conditions, our 12" media offers 90% efficiency at around 450 FPM.

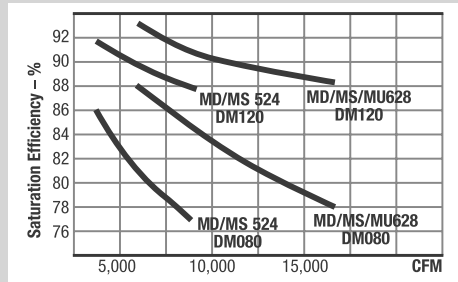

## MasterCool Evaporative Media

MasterCool evaporative media is constructed of special cellulose material, impregnated with insoluble anti-rot salts and rigidifying saturants. The cross-fluted design continually directs water to the air-entering side, inducing a highly turbulent mixing of air and water for optimum heat and moisture transfer.

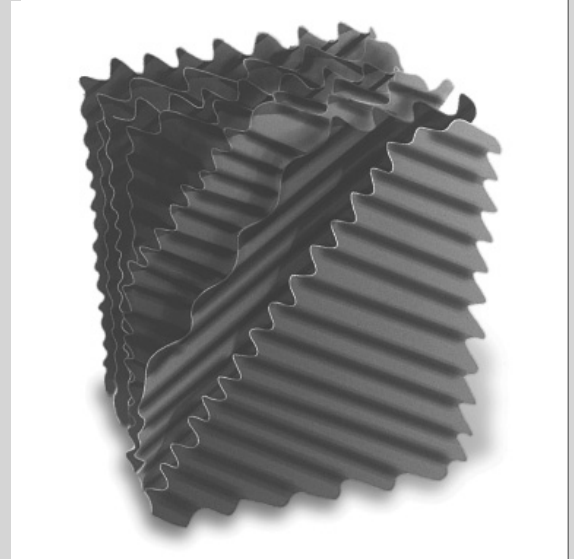

## Direct Evaporative Cooling

Put simply, whenever water is evaporated, heat is absorbed. This basic principle underlies the design of the MasterCool direct evaporative cooler.

## High Quality Construction

Hot-dipped galvanized steel, welded for maximum strength is combined with our exclusive POLYBOND® finish that protects the whole system – cabinet pans, distributor covers, louvers, and all other parts contacting water. The electrostatically applied polyester epoxy powder-based coating is cured at high temperature and is so durable that these models are backed by the best warranty in the industry.

## Energy Efficient...

### Environmentally Friendly

With no compressors or condensers, MasterCool evaporative coolers offer significant energy savings over mechanical refrigeration units; and, with no CFC's, do not contribute to depletion of the ozone layer. Their air washing effect improves indoor air quality with fresh, filtered air constantly brought into the cooled space...forcing stale air out.

## Comfort Levels

Not only does evaporative cooling lower the temperature in the space to be cooled, it also lowers the temperature you feel. Rapid air movement produced by the MasterCool increases skin evaporation which causes you to feel 3-5° effectively cooler than the temperature read from a thermometer. Evaporative cooling can provide effective temperatures acceptable in most commercial/ industrial applications throughout the world.

## Typical Applications

The Industrial MasterCool is used for area cooling or spot cooling. In many areas it can replace or supplement mechanical refrigeration needs in agricultural, institutional, commercial, and industrial applications. Applications such as kitchens, laundries, gymnasiums, heat treating areas, and dry cleaning plants requiring large quantities of fresh air moving through the building are ideal candidates for evaporative cooling.

# 2-STAGE INDUSTRIAL EVAPORATIVE COOLING

## Indirect/Direct Evaporative Cooling Process

In the indirect cooling stage, entering air is cooled along a horizontal humidity ratio line on the Psychrometric Chart (A to B) without adding moisture. In the next cooling stage, this air is further cooled along a new wet-bulb line (B to C), resulting in a lower dry-bulb temperature of leaving air than can be achieved with single stage direct evaporative cooling alone.

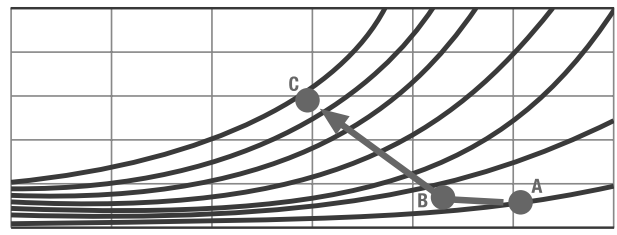

## Typical Configurations

Many configurations of 2-Stage Industrial MasterCool are possible. Typical field-assembled components include 2 or 3 Indirect Cooling Modules with Models MD/MS524 and 4 or 6 ICM's with models MD/MS/MU628 Contact your local MasterCool representative for assistance in sizing.

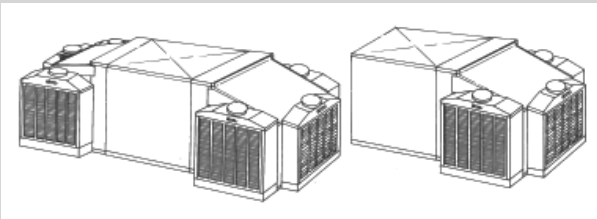

Models shown with three ICM's at each inlet location.

## The Indirect Cooling Module

Outside air is drawn into the ICM. A fan draws air through the inside of vertical fins (which have water running inside them). The air picks up heat and is expelled from the ICM while the fins are cooled by evaporation. Other outside air is drawn across the outside surfaces of the cooled fins, and is cooled without coming in contact with water. This cooled air, with no humidity added, then enters the direct evaporative section of the Industrial MasterCool for final cooling.

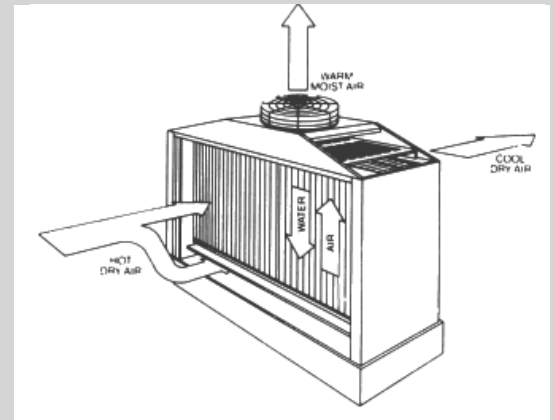

## 2-Stage Indirect/Direct Evaporative Cooling

2-Stage cooling allows you to use energy-saving evaporative cooling technology for design conditions where direct evaporative cooling alone is not adequate. A 2-stage cooler results in greater cooling power, less affected by higher ambient temperature and humidity.

In the indirect cooling stage, outside entering air is cooled sensibly reducing its total enthalpy. This "precooled" air is then evaporatively cooled in the direct cooling stage, approaching its new, lower wet-bulb temperature.

The end result is discharge temperatures near or even slightly below the wet-bulb temperature. More importantly, these lower discharge temperatures translate into customer comfort at a fraction of the cost of refrigerated air conditioning.

## Applications

With its substantial increase in cooling capacity, the indirect/direct 2-stage Industrial MasterCool can replace mechanical refrigeration in many applications.

## KoolKalk...

### Computer Aided Sizing

The sizing method described in this brochure can be used for general sizing of direct evaporative Industrial MasterCool units.

For more accurate sizing, and for sizing indirect/direct units, we recommend the use of KoolKalk... an IBM compatible computer program designed specifically for AdobeAir Evaporative Coolers. For more information please visit the AdobeAir, Inc. website at [www.AdobeAir.com](http://www.AdobeAir.com).



# DIMENSIONS AND SPECIFICATIONS

## Single Inlet Model Dimensions MD524 or UD960 (Down Discharge) and MS524 or US960 (Side Discharge)

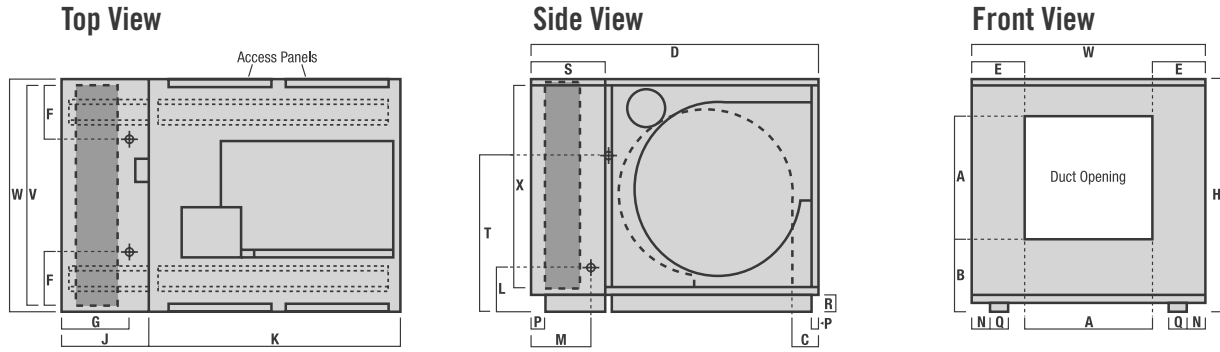

### MD/MS524 or UD/US960

Media Section Cabinet Model Number 1 Required	Cabinet			Duct Location				Drain <sup>1</sup> Location		Media Cabi- net J	Blower Cabi- net K	Water <sup>2</sup> Service Location		Electric <sup>3</sup> Service Location		Blower Wheel			Blower Pulley Pitch Dia.	Skid Location				Media Dimension		Pad Area Sq.Ft.
	H	W	D	A	B	C	E	F	G			L	M	S	T	Dia.	Width	Shaft		N	P	Q	R	X	V	
DM080 or UM080	51½	49⅞	66	26¾	17	3	11¼	13	13¾	17	49⅞	7¼	12¾	18	35½	24	24	1⅜/16	13	2	1⅝	4	2½	44⅝	48	14.8
DM120 or UM120	51½	49⅞	70	26¾	17	3	11¼	13	17¾	21	49⅞	7¼	16¾	22	35½	24	24	1⅜/16	13	2	1⅝	4	2½	44⅝	48	14.8

1. Drain is 3/4" male hose thread.
2. Water service can be left or right for 1/4" tubing.
3. 7/8" knockout for running electrical service.

### Electrical Specifications

HP	Speed	Phase	Voltage	Amperage	NEMA Frame	Shaft Diameter	Motor Kit #
¾	1	1	115/230	12.5/6.2	56	5/8	EJ006
¾	2	1	230	5.9	56	5/8	EJ020
¾	1	3	208-230/460	3.0/1.5	56	5/8	EJ883
1	1	1	115/230	15.1/7.5	56	5/8	EJ007
1	2	1	230	7.3	56	5/8	EJ021
1	1	3	208-230/460	3.6/1.7	143T	7/8	EJ665
1½	1	1	115/230	14.5/6.3	143T	7/8	EJ212
1½	1	3	208-230/460	4.6/2.2	143T	7/8	EJ666
2	1	1	115/230	19.0/8.5	143T	7/8	EJ213
2	1	3	208-230/460	7.1/3.3	143T	7/8	EJ667
3	1	3	208-230/460	8.7-8.4/4.2	182T	1⅜	EJ668
5	1	3	208-230/460	14.2-13.0/6.5	184T	1⅜	EJ659
7½	1	3	208-230/460	20.9-19.2/9.6	213T	1⅝	EJ675

- Amperage from National Electric Code.
- Single phase motors rated 230 volts can be operated at nameplate amps at 208 volts.
- See nameplate on actual motor for amperage in figuring overload protector.
- All 3-phase motors listed are suitable for use on evaporative coolers at 200 volts.

### Pump Specifications

Pump Model#	Volts	Amps	Watts	GPH At 4' Head
CP280	115	1.2	80	300
CP480	230	.6	80	300

Note: Pumps are available in 115 volt and 230 volt models. As a result, transforming or separate circuiting may be required for other voltages.

### Bleed Rates GPH per Media Module

Blower Model	Blower Motor HP						
	¾	1	1½	2	3	5	7½
524 or 960	7	8	9	10	10	—	—
628 or 980	—	11	13	14	16	18	20

# Dual Inlet Model Dimensions MD628 or UD980 (Down Discharge), MS628 or US980 (Side Discharge) and MU628 (Up Discharge)

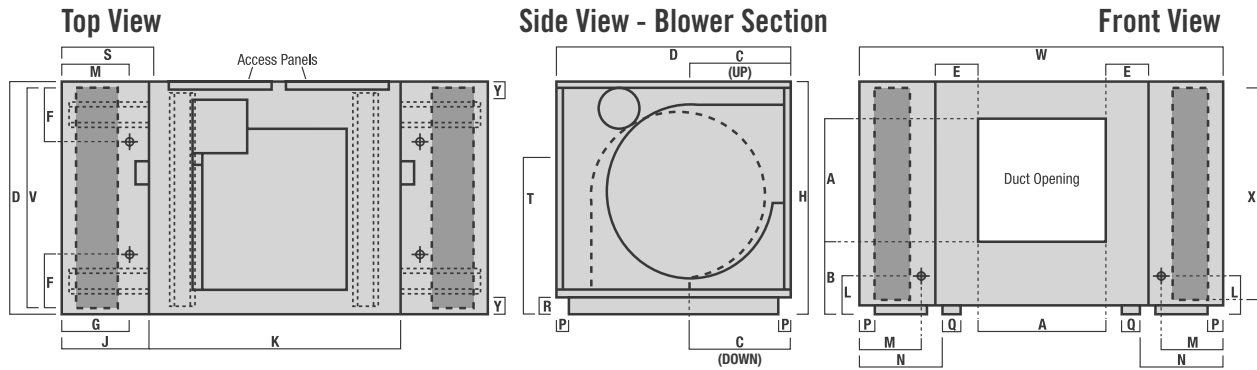

## MD/MS/MU628 or UD/US980

Media Section Model Number 1 Required	Cabinet			Duct Location				Drain <sup>1</sup> Location		Media Cabinet J	Blower Cabinet K	Water <sup>2</sup> Service Location		Electric <sup>3</sup> Service Location		Blower Wheel			Blower Pulley Pitch Dia.	Skid Location				Media Dimension		Pad Area Sq.Ft.	
	H	W	D	A	B	C	E	F	G			L	M	S	T	Dia.	Width	Shaft		N	P	Y	Q	R	X		V
DM080 or UM080	51½	83½	49½	31¾	17¾	15¼	8¾	13	13¾	17	49½	7¼	12¾	18	35½	28	28	1¾/16	18	19	1½	2	4	2½	44½	48	14.8
DM120 or UM120	51½	91½	49½	31¾	17¾	15¼	8¾	13	17¾	21	49½	7¼	16¾	22	35½	28	28	1¾/16	18	23	1½	4	4	2½	44½	48	14.8

1. Drain is 3/4" male hose thread.
2. Water service can be left or right for 1/4" tubing.
3. 7/8" knockout for running electrical service.

## Sizing Instructions

Follow these steps to properly size the Industrial MasterCool. The performance or Sensible Heat Capacity of any cooler is a function of both the CFM and saturation efficiency (which determines the delivered air discharge temperature). Sizing by only considering CFM may result in an improperly sized application.

### 1. Determine design conditions:

- Outdoor Dry-Bulb DB1
- Outdoor Wet-Bulb WB1
- Indoor Dry-Bulb T1

### 2. Determine design sensible heat load (Btuh)

### 3. Determine leaving air temperature (LAT):

$$LAT = DB1 - [(DB1 - WB) * EFF]$$

where EFF = 0.80 for 8" media or 0.90 for 12" media

### 4. Determine CFM required:

$$CFM = \frac{0.925 * \text{Sensible Heat Load}}{(T1 - LAT)}$$

### 5. Determine the cooler(s) required:

Refer to the specification / air flow charts on next page.

### 6. Use KoolKalk to account for various losses:

This will result in more accurate sizing.

## Motor Sheave Selection

1. Determine the external static pressure of the air delivery system.
2. Determine the motor (H.P., Voltage and Phase) required to deliver the design airflow.
3. Determine the shaft size for the motor selected.

Refer to the Electrical Specifications chart on facing page.

### 4. Determine the RPM that will deliver the required airflow (CFM) at the static pressure of the system.

Refer to the Certified Air Delivery CFM chart for the chosen cooler and selected motor HP.

### 5. Determine the sheave, and the number of turns open, that is closest to the desired RPM.

Refer to the Sheave Selection charts on the next page. Find the selected motor HP, shaft size, and desired RPM (See Steps 2-4 above). You might need to look at more than one sheave before finding the correct RPM.

### 6. Specify the sheave and sheave setting (turns open) for the installer.

## Ordering

When ordering your cooler, you should know this information.

- System design static pressure.
- Desired air volume at system design.
- Electrical power supply available.
- Stability of structure to support operating weight of unit.

Complete systems consist of the following components, and are sold separately for application versatility.

- Cabinet – 1 blower section
- Wet media section (1 for 524's - 2 for 628's)
- Motor
- Motor sheave
- Pulley-belt kit
- Pump (one required for each media section)

NOTE: Motor starters, internal wiring and over-current protection are not supplied.

# DIMENSIONS

## Certified Air Delivery CFM at Various External Static Pressures

Inches Water Gauge. AMCA Licensed Ratings.

Model	Operating Weight	BHP	Quantity	Belt information			.0 CFM	.0 RPM	.1 CFM	.1 RPM	.2 CFM	.2 RPM	
				Down	Side	Up							
<b>524 with DM080 or 960 with UM080 — 8" Media</b>													
	560	¾	1	AX78	AX80		6390	298	6070	310	5710	320	
	570	1	1	AX78	AX80		7030	329	6760	339	6420	349	
	575	1½	1	AX78	AX80		8050	376	7810	385	7530	394	
	580	2	1	AX78	AX80		8860	414	8640	422	8400	430	
	590	3	1	AX78	A82*		9050	422	9050	440	9050	459	
<b>524 with DM120 or 960 with UM120 — 12" Media</b>													
	600	¾	1	AX78	AX80		6250	298	5900	309	5550	321	
	610	1	1	AX78	AX80		6880	328	6560	338	6250	349	
	615	1½	1	AX78	AX80		7880	376	7600	384	7320	393	
	620	2	1	AX78	AX80		8670	414	8420	421	8160	429	
	630	3	1	AX78	A82*		9050	422	9050	439	9050	458	
<b>628 with two DM080 or 980 with two UM080 — 8" Media</b>													
	818	1	1	A95*	A95*	A95	9720	214	9320	224	8650	235	
	823	1½	1	A95*	A95*	A95	11130	245	10720	254	10230	263	
	828	2	1	A95*	A95*	A95	12250	270	11890	278	11460	286	
	838	3	2	A97	A97	A95	14020	309	13720	316	13350	323	
	858	5	2	A97	A97	A95	16620	367	16390	371	16080	378	
	898	7½	2	A100*	A100*	A95	/ / / / / / / / / /		18100	406	18100	418	
<b>628 with two DM120 or 980 with two UM120 — 12" Media</b>													
	908	1	1	A95*	A95*	A95	9680	216	9080	226	8530	237	
	913	1½	1	A95*	A95*	A95	11080	248	10540	256	10080	265	
	918	2	1	A95*	A95*	A95	12190	273	11700	280	11260	288	
	928	3	2	A97	A97	A95	13950	312	13510	318	13130	325	
	948	5	2	A97	A97	A95	16540	370	16050	375	15820	380	
	988	7½	2	A100*	A100*	A95	18100	406	18100	409	18100	428	

**Shaded Areas:** Do not exceed listed RPM, water entrainment may result.

\*Not supplied: MS524 coolers with a 3 HP motor require the purchase of one A82 belt (AX78 belt included with unit). MD628 and MS628 coolers with 1, 1½ or 2 HP motor requires one A95 belt (two A97 belts included with unit). MD628 and MS628 coolers with 7½ HP motor require two A100 belts (two A97 belts included with unit).

/ / / / / / / / / /

NOT RECOMMENDED

## MD/MS 524 or UD/US 960 Sheave Selection

Motor HP	Browning Part #	Bore	Blower RPM / Sheave Turns Open											MasterCool Package #
			5	4½	4	3½	3	2½	2	1½	1	½	0	
<b>Single Phase Motor Blower RPM @ 1725 Motor RPM / Sheave Turns Open</b>														
¾, 1	1VL34	⅝	252	265	279	292	305	318	332	345	358	372	385	EL114
¾, 1	1VL40	⅝	318	332	345	358	372	385	398	411	425	438	451	EL110
1½, 2	1VL40	⅞	318	332	345	358	372	385	398	411	425	438	451	EL112
¾, 1	1VL44	⅝	372	385	398	411	425	438	451	464	478	491	504	ESH2411
1½, 2	1VL44	⅞	372	385	398	411	425	438	451	464	478	491	504	EL685
1½, 2	1VP50	⅞	451	464	478	491	504	518	531	544	557	571	584	686
<b>Three Phase Motor Blower RPM @ 1750 Motor RPM / Sheave Turns Open</b>														
¾	1VL34	⅝	256	269	283	296	310	323	337	350	363	377	390	EL114
1	1VL34	⅞	256	269	283	296	310	323	337	350	363	377	390	EL116
¾	1VL40	⅝	323	337	350	363	377	390	404	417	431	444	458	EL110
1, 1½, 2	1VL40	⅞	323	337	350	363	377	390	404	417	431	444	458	EL112
¾	1VL44	⅝	377	390	404	417	431	444	458	471	485	498	512	ESH2411
1, 1½, 2	1VL44	⅞	377	390	404	417	431	444	458	471	485	498	512	EL685
3	1VL44	1⅝	377	390	404	417	431	444	458	471	485	498	512	684
1½, 2	1VP50	⅞	458	471	485	498	512	525	538	552	565	579	592	686
3	1VP50	1⅝	458	471	485	498	512	525	538	552	565	579	592	685

.3 CFM	.3 RPM	.4 CFM	.4 RPM	.5 CFM	.5 RPM	.6 CFM	.6 RPM	.7 CFM	.7 RPM	.8 CFM	.8 RPM	.9 CFM	.9 RPM	1.0 CFM	1.0 RPM
5320	333	4850	348	4200	373	3670	391	3200	408	2770	426	2400	443	2060	460
6080	359	5720	371	5280	386	4660	409	4160	426	3720	442	3310	458	2940	473
7250	402	6930	412	6630	422	6240	434	5840	449	5260	471	4830	485	4440	499
8140	438	7880	446	7590	455	7310	464	6970	475	6630	487	6140	505	5660	523
9050	475	9050	491	9050	508	8820	516	8570	524	8330	532	8030	542	7730	552
5170	334	4720	349	4070	371	3590	390	3140	407	2740	423	2340	441	1980	458
5910	360	5540	373	5130	386	4510	408	4060	425	3650	441	3270	455	2900	471
7040	403	6740	413	6430	424	6070	435	5620	450	5110	469	4710	484	4350	498
7920	438	7650	447	7380	456	7100	466	6760	476	6440	487	5930	505	5510	520
9050	475	9050	492	8820	509	8570	518	8340	526	8080	534	7790	544	7520	553
8030	246	7380	260	6670	276	5240	308	4540	326	3840	345	3290	363	2740	379
9700	273	9160	283	8600	294	7990	307	7030	329	5890	354	5290	371	4690	387
10980	294	10510	303	10010	313	9500	323	8960	335	8360	348	6990	379	6280	395
12960	330	12540	337	12130	345	11690	353	11250	362	10800	371	10330	382	9810	393
15770	384	15450	390	15090	396	14730	402	14390	409	14020	416	13660	423	13280	430
18100	431	18030	440	17760	445	17440	450	17130	455	16820	461	16520	467	16210	473
7930	248	7220	261	6490	279	5130	310	4390	329	3810	345	3220	361	2630	376
9570	274	9030	285	8420	296	7810	310	6930	330	5760	358	5130	374	4600	388
10830	297	10350	306	9860	315	9310	325	8730	337	8110	353	6900	379	6150	398
12760	332	12370	340	11960	348	11530	356	11070	364	10580	373	10070	384	9630	396
15510	386	15190	393	14890	399	14530	406	14190	412	13820	419	13460	426	13060	433
18010	437	17730	443	17450	448	17190	454	16900	459	16590	465	16300	471	15970	477

- Power ratings (BHP) does not include drive losses.
- Performance ratings include the effects of evaporative media in the airstream.
- Belt tension should be 20 pounds for "A" section belts.
- Performance shown is for installation type B: Free Inlet, Ducted Outlet.

## MD/MS/MU 628 or UD/US 980 Sheave Selection

Motor HP	Browning Part #	Bore	Blower RPM / Sheave Turns Open											MasterCool Package #
			5	4 ½	4	3 ½	3	2 ½	2	1 ½	1	½	0	
<b>Single Phase Motor Blower RPM @ 1725 Motor RPM / Sheave Turns Open</b>														
1	1VL40	5/8	230	240	249	259	268	278	288	297	307	316	326	EL110
1 ½, 2	1VL40	7/8	230	240	249	259	268	278	288	297	307	316	326	EL112
1	1VL44	5/8	268	278	288	297	307	316	326	335	345	355	364	ESH2411
1 ½, 2	1VL44	7/8	268	278	288	297	307	316	326	335	345	355	364	EL685
1	1VP50	5/8	326	335	345	355	364	374	383	393	403	412	422	693
1 ½, 2	1VP50	7/8	326	335	345	355	364	374	383	393	403	412	422	686
<b>Three Phase Motor Blower RPM @ 1750 Motor RPM / Sheave Turns Open</b>														
1, 1 ½, 2	1VL34	7/8	185	194	204	214	224	233	243	253	263	272	282	EL116
1, 1 ½, 2	1VL40	7/8	233	243	253	263	272	282	292	301	311	321	331	EL112
1, 1 ½, 2	1VL44	7/8	272	282	292	301	311	321	331	340	350	360	369	EL685
1, 1 ½, 2	1VP50	7/8	331	340	350	360	369	379	389	399	408	418	428	686
3	2VP42	1 ½	253	263	272	282	292	301	311	321	331	340	350	687
3, 5	2VP50	1 ½	331	340	350	360	369	379	389	399	408	418	428	688
5	2VP60	1 ½	408	418	428	438	447	457	467	476	486	496	506	689
7 ½	2VP60	1 ½	408	418	428	438	447	457	467	476	486	496	506	692



# Project Submittal Sheet

Models MD/MS 524, MD/MS/MU 628 — U.L. Classified or UD/US 960, UD/US 980 — U.L. Listed

Project	SHL*
Location	
Architect	
Engineer	
Contractor	
Submitted By	Date

\*Total design sensible heat load of project.

## Blower Section – Motor – Motor Sheave – Pulley and Belt Kit

Ref. No.	Blower Section		Motor Specifications				Kits Motor Sheave	Belt
	Qty.	Model No.	Motor HP	Volts	Phase	Amps		
1								
2								
3								
4								

\*NOTE: Each unit (ready to operate) consists of one blower section, one blower motor, one pulley-belt kit, one motor sheave.

## Wet Section – Pump

Ref. No.	Wet Section		Pump Quantity	Volts	Amps	GPM
	Qty.	Model No.				
1						
2						
3						
4						

\*NOTE: Each wet section (ready to operate) consists of one wet module and one pump.

### Your local MasterCool Representative of AdobeAir, Inc., is ready to assist you in unit selection and application.

The world leader in evaporative cooling technology, AdobeAir, Inc. is continually involved in the process of product improvement. AdobeAir, Inc. therefore reserves the right to change specifications and/or design without prior notice. To obtain the most current product information and/or specifications, visit the AdobeAir, Inc. web site at [www.AdobeAir.com](http://www.AdobeAir.com).

Manufactured in Mexico by:  
**AdobeAir, Inc.**  
 1450 East Grant St.  
 Phoenix, AZ 85034  
[www.AdobeAir.com](http://www.AdobeAir.com)

**MasterCool evaporative coolers and components are designed and tested in accordance with one or more of the following standards or agencies:**

**Air Delivery:** Data published derived from tests conducted in accordance with A.M.C.A. (Air Movement and Control Assoc.) Standard 210.

**Sealant:** Water Immersion: per ASTM D870. Flexibility: per ASTM D756. Corrosion Resistance: per ASTM B117. Cycle Freeze/Thaw: per ASTM C117.

**POLYBOND®:** Corrosion Resistance: per ASTM B117. Pencil Hardness: per ASTM D3363. Adhesion: per ASTM D3359. Impact Resistance: per ASTM D2794. Flexibility: per ASTM D522. Specular Gloss: per ASTM D523. Surface Burning Characteristics of Building Materials (best rating) per U.L. 723 and ASTM E-84.

**Pumps:** Recognized under the U.L. component recognition program for the application – construction, thermal overload, running overload, and locked rotor protection.

**Blower Motors:** U.L. Recognized general purpose drip-proof.

**Polymeric Materials:** Tested in accordance with U.L. 94 and 746C. Covered by City of Los Angeles Research Reports (C.O.L.A.) RR930224 (for all single phase applications), or RR930190 (for 3 phase applications) Electrical, and RR8141 Mechanical.