

OWNER'S MANUAL
Model No. GRP4PTMR

GEORGE FOREMAN®

**LEAN
MEAN
FAT REDUCING
GRILLING
MACHINE!**

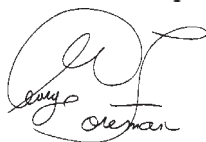

THE NEXT GRILLERATION™



salton®

IMPORTANT SAFEGUARDS

When using electrical appliances, basic safety precautions should always be followed, including the following:

1. Read all instructions.
2. Do not touch hot surfaces. Use handles or knobs. Use oven mitts or pot holders.
3. To protect against electric shock, do not immerse cord, plugs, or appliance in water or other liquid.
4. Close supervision is necessary when any appliance is used by or near children.
5. Unplug from outlet when not in use and before cleaning. Allow to cool before putting on or taking off parts, and before cleaning the appliance.
6. Do not operate any appliance with a damaged cord or plug or after the appliance malfunctions, or has been damaged in any manner. Contact Consumer Service for examination, repair or adjustment.
7. The use of accessory attachments not recommended by the appliance manufacturer may cause injuries.
8. Do not use outdoors.
9. Do not let cord hang over edge of table or counter, or touch hot surfaces.
10. Do not place on or near a hot gas or electric burner, or in a heated oven.
11. Extreme caution must be used when moving an appliance containing hot oil or other hot liquids. Allow liquid to cool before removing and emptying drip tray.
12. To disconnect, press ON/OFF Power Button 'off', then remove plug from wall outlet.
13. Do not use appliance for other than intended use.

SAVE THESE INSTRUCTIONS

For Household Use Only

Additional Important Safeguards

CAUTION HOT SURFACES: *This appliance generates heat and escaping steam during use. Proper precautions must be taken to prevent the risk of burns, fires, or other injury to persons or damage to property.*

CAUTION: *This appliance is hot during operation and retains heat for some time after turning off. Always use oven mitts when handling hot materials and allow metal parts to cool before cleaning. Do not place anything on top of the appliance while it is operating or while it is hot.*

1. All users of this appliance must read and understand this Owner's Manual before operating or cleaning this appliance.
2. The cord to this appliance should be plugged into a 120V AC electrical outlet only.
3. If this appliance begins to malfunction during use, immediately unplug cord from outlet. Do not use or attempt to repair the malfunctioning appliance.
4. Do not leave this appliance unattended during use.
5. When using this appliance, provide adequate air space above and on all sides for air circulation. Do not allow this appliance to touch curtains, wall coverings, clothing, dish towels or other flammable materials during use.
6. This appliance generates steam — do not operate in open position.
7. **Using pot holder, hold the top cover (Lid) open while placing or removing food on the cooking surface to prevent accidental closing and injury.**

Polarized Plug

This appliance has a **polarized plug** (one blade is wider than the other). To reduce the risk of electric shock, this plug is intended to fit into a polarized outlet only one way. If the plug does not fit fully in the outlet, reverse the plug. If it still does not fit, contact a qualified electrician. Do not attempt to modify the plug in any way.

Short Cord Instructions

A short power-supply cord is provided to reduce the risk resulting from becoming entangled in or tripping over a longer cord.

Do not use an extension cord with this product.

Electric Power

If the electrical circuit is overloaded with other appliances, your appliance may not operate properly. It should be operated on a separate electrical circuit from other appliances.

Plasticizer Warning

CAUTION: To prevent Plasticizers from migrating from the finish of the counter top or table top or other furniture, place **NON-PLASTIC** coasters or placemats between the appliance and the finish of the counter top or table top.

Failure to do so may cause the finish to darken, permanent blemishes may occur or stains can appear.

Getting To Know Your Grilling Machine

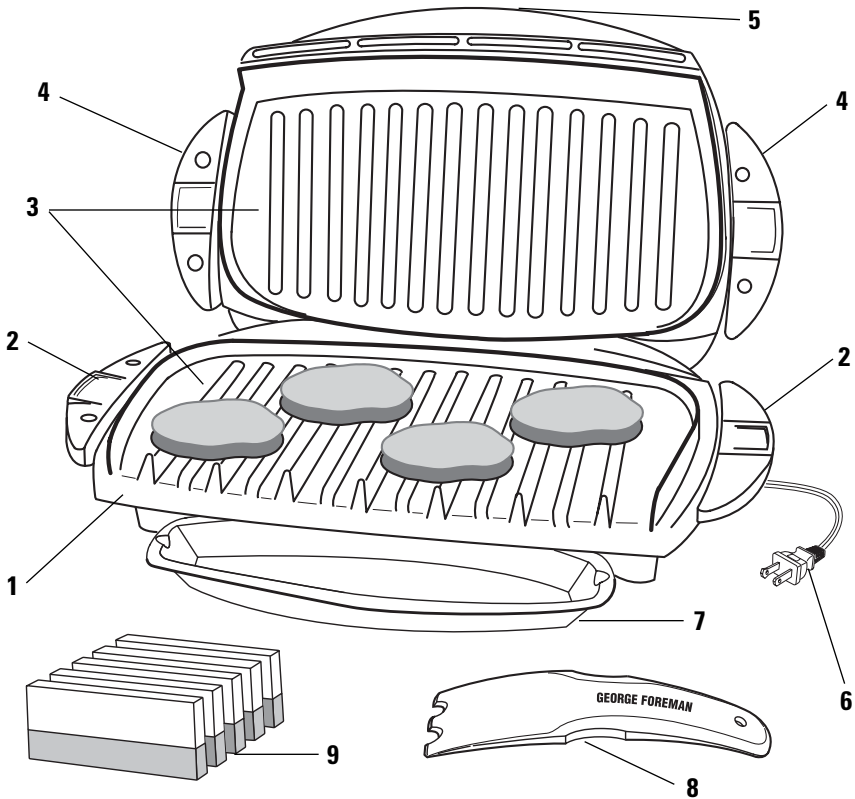

- 1. Grilling Machine Body
- 2. Lower Grilling Plate Release Handles
- 3. Grilling Plates
Upper Grilling Plate (P/N 22618U)
Lower Grilling Plate (P/N 22618L)
- 4. Upper Grilling Plate Release Handles
- 5. Control Panel
- 6. Power Cord
- 7. Drip Tray (P/N 22619)
- 8. Plastic Spatula (P/N 22545)
- 9. Sponge (GFSP1)
- 10. ON/OFF Power Button
- 11. Timer Display (LED)

- 12. Timer Down Button
- 13. Timer Up Button

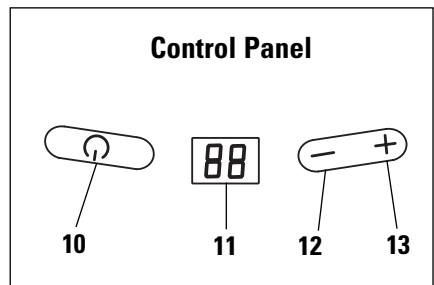

How To Use George Foreman's Lean Mean Fat Reducing Grilling Machine

1. Before using the Grilling Machine for the first time, remove the Grilling Plates and wash them in warm soapy water. Rinse and dry thoroughly. Make sure both Grilling Plates are firmly attached to the appliance.
2. **To preheat:** Close the Lid and plug cord into a 120V AC polarized outlet. The Timer display will show a "--". Press the ON/OFF Button. The Timer Display will show a "5", indicating the start of the 5 minute pre-heat countdown. When the countdown is complete the unit will beep 4 times. The Timer Display will show "on" as a reminder that the power is still on.
3. Use a potholder to carefully open the Lid.
4. Slide the Drip Tray under the front of the unit.
5. Carefully place the items to be cooked on the bottom cooking plate.
6. Close the Lid and press the Timer Up Button to set the desired grilling time. You can adjust the time up to 20 minutes. The Timer Display will show the set time. To adjust the Timer down, simply press the Timer Down Button.
7. Allow the food to cook for the desired time. (Consult the Recipe Section at the back of this book for some suggestions.) ***Do not leave appliance unattended during use!***
During grilling, the Timer Display will begin counting down. When the set time has elapsed the unit will beep 4 times.
8. After the desired amount of time, the food should be done.
9. Press the ON/OFF Button to turn off the Grill. If the unit is not turned off, it will automatically shut off after one hour. Disconnect the plug from the wall outlet.
CAUTION: To avoid any sparks at the outlet while disconnecting plug, make sure the ON/OFF Power Button is off "--" before disconnecting the plug from the outlet.
10. Use a potholder to carefully open the Lid.
11. Remove the food using the Plastic Spatula provided. Be sure to always use either plastic or wooden utensils so as not to scratch the non-stick surface. Never use metal tongs, forks or knives as these can damage the coating on the cooking plates.
12. When cool, the Drip Tray may be removed and emptied. **Be sure the liquid is cooled before removing Drip Tray.**

Suggested Cooking Chart

	Rare (145°F)*	Medium (160°F)*	Well (170°F)*
Salmon Filet (1 1/2" thick)	7 min.	8 min.	9 min.
Talapia Fish (3/4" thick)	3 min.	4 min.	5 min.
Tuna Steak (1" thick)	6 min.	7 min.	8 min.
White Fish (1" thick)	7 min.	8 min.	9 min.
Shrimp, split with shell		2 min.	2 1/2 min.
4 oz. Turkey Burgers			6 1/2 min.
8 oz. Turkey Burgers			7 1/2 min.
Pork Loin (1/2" thick)		5 min.	7 min.
4 oz. Burgers		5 min.	6 min.
8 oz. Burgers		10 min.	11 min.
Chicken Breast (boneless/skinless)			9 min.
Link Sausage		5 min.	6 min.
Sliced Sausage (1/2" thick)		5 min.	6 min.
Fajita Beef (1/2" thick slices)	1 min.	1 1/2 min.	2 min.
Rib Eye (1/2" thick)	3 1/2 min.	4 1/2 min.	5 1/2 min.
NY Strip (3/4" thick)	4 min.	5 min.	6 min.
Bratwurst		8 min.	10 min.
Frankfurter		5 min.	7 min.
Onions and Peppers (1/2" thick, toss with olive oil)		4 min.	5 min.

NOTE: Most meats were 1" thick. These are recommended guidelines only. Personal taste and thickness of cut may vary cooking times. Always check for doneness and always use fresh, refrigerated foods.

PLEASE NOTE: The USDA recommends that meats such as beef and lamb, etc. should be cooked to an internal temperature of 145°F. Pork should be cooked to an internal temperature of 160°F and poultry products should be cooked to an internal temperature of 170°F - 180°F to be sure any harmful bacteria has been killed. When reheating meat/poultry products, they should also be cooked to an internal temperature of 165°F.

*Internal Food Temperatures

User Maintenance Instructions

CAUTION: To avoid accidental burns, allow your Grilling Machine to cool thoroughly before cleaning.

1. Before cleaning, unplug the appliance from the wall outlet and allow to cool.

CAUTION: To avoid any sparks at the outlet while disconnecting plug, make sure the ON/OFF Power Button is off "--" before disconnecting the plug from the outlet.

2. **Inside cleaning:** Place the Drip Tray under the front of the Grilling Machine. Using the specially designed Spatula, scrape off any excess fat and food particles. Run-off will drip into the Drip Tray. Wipe the plates with the George Foreman specially designed Grill Sponge.
3. Empty the Drip Tray and wash with warm soapy water. The Grilling Plates may be removed from the appliance by pulling out on the Grilling Plate Release Handles. Wash in warm, soapy water, rinse and dry thoroughly. Reinstall the Grilling Plates, making sure they are securely attached to the appliance. The removable Grilling Plates are also dishwasher safe. After washing the Plates in the dishwasher, wipe the uncoated side with a dry towel to prevent discoloration. Dishwasher detergent may cause oxidation on the uncoated side of the cooking plate. This is not harmful and can be wiped off with a damp towel.
4. **Stubborn build-up:** Use the scouring side of the Grill Sponge to clean the plates.
5. **Outside cleaning:** Wipe with a warm, wet sponge and dry with a soft, dry cloth.
6. To clean the Bun Warmer surface, simply wipe with a clean, damp cloth or sponge. Do not use harsh or abrasive cleaners!
7. Do not use steel wool, scouring pads, or abrasive cleaners on any part of the appliance.
8. **DO NOT IMMERSE THE BODY OF THE APPLIANCE IN WATER OR OTHER LIQUID.**
9. Any servicing requiring disassembly other than the above cleaning must be performed by a qualified electrician.
10. Make sure to hold the top cover (Lid) by hand while cleaning to prevent accidental closing and injury.

Recipes

NOTE: For all recipes, please remember to place Drip Tray in front of the Grilling Machine to catch drippings from the cooking process.

Mushroom Tenderloin Steaks

A tasty entrée for a busy weeknight.

2 8 oz. beef tenderloin steaks, 3/4 - inch thick
1 Tbsp. fresh parsley, finely minced
1 clove garlic, finely minced
1/8 tsp. salt
1/8 tsp. black pepper
4 oz. fresh or canned mushroom slices, drained
1 Tbsp. olive oil

Allow the grill to preheat. In a small bowl, combine the mushrooms and olive oil. Remove any visible fat from the steaks. Sprinkle each steak with the parsley, garlic, salt and pepper. Place the steaks on the grill and cook for 2 minutes. Spoon the mushroom slices over the steaks and grill for an additional 1 1/2 - 2 1/2 minutes.

Serves 2

Hawaiian Pineapple Beef

Flavorful and delicious!

1 lb. London broil beef steak, 1/2 - inch thick
2 Tbsp. green onion, finely minced
1 tsp. ground ginger
1 Tbsp. honey
1/2 cup fresh pineapple, cut into small pieces (or 1/2 cup canned pineapple chunks, drained)

Remove any visible fat from the steak and cut into 4 equal pieces. In a small bowl, combine the green onion, ginger and honey and mix well. Allow the grill to preheat. Place the steak on the grill and spoon the sauce over the steak.

Grill for 2 minutes, add the pineapple pieces on top of the steak and grill for an additional 1-2 minutes. To serve, slice the steak thinly across the grain and spoon the warm pineapple over the top.

Serves 4

Quick and Easy Pork Tenderloin

A 15-minute entrée from start to finish!

2 8 oz. pork tenderloins, 1 - inch thick
1/4 cup low sodium soy sauce
2 tsps. ground ginger
4 green onions, chopped
1 clove garlic, chopped
1/2 tsp. black pepper

Remove all visible fat from the pork. Combine the soy sauce, ginger, green onions, garlic and pepper in a flat glass pan. Allow the grill to pre-heat. Quickly dip each tenderloin into the soy ginger sauce and place on the grill.

Spoon 1 tablespoon of sauce over each tenderloin. Grill for 8 minutes or continue grilling according to your preference.

Serves 2

New Orleans Pork Ribs

These boneless ribs take less time and effort to prepare than traditional ribs.

1 1/2 lb. boneless, country-style, pork ribs
1/4 cup tomato paste
1/4 cup cider vinegar
2 Tbsp. honey
2 Tbsp. water
1 Tbsp. extra virgin olive oil
2 tsp. dry mustard
1/2 tsp. Tabasco sauce
1 clove garlic, minced
1/4 cup yellow onion, finely chopped

Remove any visible fat from the ribs. Score the ribs with a knife to prevent the meat from curling as it grills. In a small saucepan, combine the remaining ingredients and blend until thickened, about 5 minutes, and keep warm.

Allow the grill to preheat. Place the ribs on the grill and cover each with 1 tablespoon of sauce. Grill for 5 minutes. Open the grill, turn the ribs and baste each with 1 tablespoon of sauce. Grill for 2-4 minutes, or until cooked through. Serve with the remaining warm sauce.

Serves 4

Thai Salmon Steaks

Wonderfully vibrant, tangy flavors!

1 tsp. rice vinegar
2 Tbsp. low sodium soy sauce
1/4 cup honey
2 Tbsp. prepared Chinese mustard
2 Tbsp. fresh parsley, finely minced
2 7-8 oz. salmon steaks, 1 - inch thick

In a small saucepan, combine the vinegar, soy sauce, honey, mustard and parsley. Simmer for 5 minutes.

Allow the grill to preheat. Place the steaks on the grill and cover each with a tablespoon of the Thai sauce. Close the grill and cook for 6 minutes. Check the salmon and continue grilling if needed. Serve with any remaining sauce.

Serves 2

Orange Roughy Primavera

Orange roughy is sweet, mild and very delicate.

1/2 small zucchini, cleaned
1/2 red pepper, cleaned
1/2 yellow onion
1/2 carrot, peeled
1 tsp. fresh rosemary, minced
1 tsp. fresh thyme, minced
1 tsp. black pepper, coarsely ground
2 Tbsp. extra virgin olive oil
4 4-5 oz. orange roughy fillets, 1/2 - inch thick

Thinly slice the zucchini, red pepper, onion and carrot. In a small bowl, combine the rosemary, thyme, pepper and oil. Allow the grill to preheat. Place the vegetables on the grill and drizzle one half of the herb oil over them. Close the grill and cook for 5 minutes.

Remove the vegetables and add the fillets. Drizzle the remaining herb oil over the fillets, and close the grill. Cook for 2-3 minutes.

Check the fish and continue grilling, if needed, until the fish flakes easily. To serve, carefully remove the fillets from the grill and top with the vegetables.

Serves 4

Tandoori Grilled Chicken

The yogurt-based marinade creates exotic, tender chicken!

8 oz. carton unflavored lowfat yogurt
1 Tbsp. lemon juice
2 tsps. ground paprika
2 cloves garlic, minced
1/2 tsp. salt
1/2 tsp. ground ginger
1/2 tsp. ground cumin
1/2 tsp. cayenne pepper
1/2 tsp. ground cinnamon
1 lb. boneless, skinless chicken breast tenders

In a small bowl, mix together the yogurt, lemon juice, paprika, garlic, salt, ginger, cumin, cayenne pepper and cinnamon. Place the chicken tenders in a shallow glass pan and pour the marinade over the pieces, turning to coat thoroughly. Cover tightly and refrigerate for 1-8 hours, turning occasionally.

Allow the grill to preheat. Discard the marinade. Place half of the chicken on the grill and cook for 2 1/2 - 3 1/2 minutes. Check the chicken with the tip of a knife. If the chicken is not cooked completely through, continue grilling for 1 minute. Repeat with the remaining chicken.

Serves 4

Ranchero Burgers

Made with beef, beans and spices, these are surprisingly good – and good for you.

3/4 lb. extra lean ground round
1/2 cup canned kidney beans, drained and mashed
2 cloves garlic, minced
2 Tbsp. prepared barbeque sauce
1/2 tsp. salt
1/2 tsp. black pepper
4 sesame seed hamburger buns

Mix together thoroughly the beef, beans, garlic, barbeque sauce, salt and pepper. Shape into 4 patties.

Allow the grill to preheat. Place the burgers on the grill and cook for 5-6 minutes. Check the burgers and continue grilling if desired. Place each hamburger on a sesame bun and serve with your choice of condiments.

Serves 4

Grilled Garden Vegetable Sandwiches

A healthy alternative to fast-food lunches

2 zucchini, thinly sliced
1/2 small purple or red onion, thinly sliced
1 red pepper, seeded and thinly sliced
10 shiitake mushrooms, thinly sliced
1 cup eggplant, diced
1/4 cup extra virgin olive oil
1 clove garlic, finely minced
1 tsp. black pepper, coarsely ground
1 tsp. salt
4 onion rolls, split and toasted
1/4 cup lowfat Parmesan cheese, grated

In a small bowl, combine the zucchini, onion, pepper, mushrooms, eggplant, olive oil, garlic, pepper and salt. Allow the grill to preheat.

Carefully open the grill and layer one-fourth of the zucchini, onion, red pepper, mushrooms and eggplant on the grilling plate.

Close the grill and cook for 4-6 minutes. Remove and grill the remaining vegetables as directed above. Top each roll with equal portions of the vegetables and sprinkle Parmesan cheese over each sandwich.

Serves 4

Chicken Cheese Quesadillas

A simple "quick-fix" for any time of the day.

2 boneless, skinless chicken breast halves
4 large flour tortillas
1 cup lowfat shredded cheddar cheese
2 Tbsp. green onion, chopped
1/2 cup prepared mild tomato salsa

Allow the grill to preheat. Place the chicken on the grill and cook for 9 minutes. Check the chicken with the tip of a knife. If the chicken is not cooked completely through, continue grilling for 1 to 2 minutes. Cool and chop into small pieces.

On one half of one tortilla, place one-fourth of the chicken, cheese, onion and salsa. Fold the top half over the cheese and chicken. Place the quesadilla on the grill. Cook for 2-3 minutes and grill until the quesadilla is lightly browned and the cheese is melted. Remove and grill the remaining quesadillas as directed above.

Serves 4

Frequently Asked Questions

Question	Response
1. Can I cook frozen food on my George Foreman Grill?	It is preferable that food be defrosted before placing on the George Foreman Grill. Make sure that the Grill is preheated, see preheat instructions, before placing food on the grilling plate.
2. Can I cook kabobs on the George Foreman Grill?	Yes. In order to protect the non-stick surface use wooden skewers. We recommend that you soak the skewers first in water for about 20 minutes. This will keep the skewers from burning.
3. After cooking with garlic, how can I remove the smell of the garlic from the surface of my George Foreman Grill?	After cleaning your George Foreman Grill according to the "User Maintenance Instructions" make a paste of baking soda and water and spread on the surface of the Grill. Allow it to sit for a few minutes and then remove and wash according to "User Maintenance Instructions."
4. How can I cook hot dogs on my George Foreman Grill?	Preheat your Grill for 7 minutes. Place the hot dogs lengthwise on the Grill. Close the Lid and cook for 6 minutes or until desired browning is achieved.
5. Can hash browns be prepared on my George Foreman Grill?	Yes, self-browning hash browns can be prepared by preheating the Grill for 7 minutes. Add hash browns onto the Grill surface, close the Lid, and cook for approximately half the time stated on the package for oven preparation.
6. Any other cooking suggestions?	Brush green peppers with oil and slit on edges to flatten. Grill for 10 minutes then steam in a bag for 10 minutes before peeling. Grilled cheese sandwiches can also be cooked on your George Foreman Grill.

LIMITED ONE-YEAR WARRANTY

Warranty Coverage: This product is warranted to be free from defects in materials or workmanship for a period of one (1) year from the original purchase date. This product warranty is extended only to the original consumer purchaser of the product and is not transferable. For a period of one (1) year from the date of original purchase of the product, our Repair Center will, at its option, either (1) repair the product or (2) replace the product with a reconditioned comparable model. These remedies are the purchaser's exclusive remedies under this warranty.

Warranty Service: To obtain warranty service, you must call our warranty service number at 1-800-233-9054 for return instructions on how to deliver the product, in either the original packaging or packaging affording an equal degree of protection to the Repair Center specified below. You must enclose a copy of your sales receipt or other proof of purchase to demonstrate eligibility for warranty coverage.

To return the appliance, ship to:

ATTN: Repair Center
708 South Missouri Street
Macon, MO 63552 USA

To contact us, please write to, call, or email:

Consumer Relations Department
PO Box 7366
Columbia MO 65205-7366 USA
1-800-233-9054
E-mail:
consumer_relations@toastmaster.com

What Is Not Covered: This warranty does not cover damage resulting from misuse, accident, commercial use, improper service or any other damage caused by anything other than defects in material or workmanship during ordinary consumer use. This warranty is invalid if the serial number has been altered or removed from the product. This warranty is valid only in the United States and Canada.

LIMITATION ON DAMAGES: THERE SHALL BE NO LIABILITY FOR ANY INCIDENTAL OR CONSEQUENTIAL DAMAGES FOR BREACH OF ANY EXPRESS OR IMPLIED WARRANTY OR CONDITION ON THIS PRODUCT.

DURATION OF IMPLIED WARRANTIES: EXCEPT TO THE EXTENT PROHIBITED BY APPLICABLE LAW, ALL IMPLIED WARRANTIES AND CONDITIONS, INCLUDING, WITHOUT LIMITATION, IMPLIED WARRANTIES AND CONDITIONS OF MERCHANTABILITY AND FITNESS FOR A PARTICULAR PURPOSE OR USE ON THIS PRODUCT ARE LIMITED IN DURATION TO THE DURATION OF THIS WARRANTY.

Some jurisdictions do not allow the exclusion or limitation of incidental or consequential damages, or allow limitations on how long an implied warranty lasts, so the above limitations or exclusions may not apply to you. This warranty gives you specific legal rights and you may have other rights under the laws of your jurisdiction.

For more information on our products, visit our website: www.maxim-toastmaster.com

Printed in China