

Cuisinart™

INSTRUCTION
AND RECIPE
BOOKLET



Sandwich Grill

WM-SW2

For your safety and continued enjoyment of this product, always read the instruction book carefully before using.

TABLE OF CONTENTS

Important Safeguards	Page 2
Instructions for Use	Page 3
Special Features	Page 3
Tips & Hints	Page 4
Recipes	Page 4-6
Cleaning and Maintenance	Page 7
Storage	Page 7
Warranty	Page 7

IMPORTANT SAFEGUARDS

When using an electrical appliance, basic safety precautions should always be followed, including the following:

- 1. READ ALL INSTRUCTIONS.**
2. Do not touch hot surfaces. Use handles and knobs.
3. To protect against fire, electrical shock, and injury to persons, **DO NOT IMMERS**E CORD, PLUG, OR UNIT in water or other liquids.
4. Close supervision is necessary when any appliance is used by or near children.
5. Unplug from outlet when not in use and before cleaning. Allow to cool before putting on or taking off parts, and before cleaning appliance.
6. Do not operate any appliance with a damaged cord or plug or after the appliance malfunctions or has been damaged in any manner. Return appliance to the nearest Cuisinart Authorized Service Facility for examination, repair, or adjustment.
7. The use of accessory attachments not recommended by Cuisinart may result in fire, electrical shock, or injury to persons.
8. Do not use outdoors.
9. Do not let power cord hang over edge of table or counter, or touch hot surfaces.
10. Do not place on or near a hot gas or electric burner, or in a heated oven.
11. Unplug the unit when finished cooking.
12. Do not use appliance for other than intended use.
13. Extreme caution must be used when moving an appliance containing hot oil or other hot liquids.

14. Always attach plug to appliance first, then plug cord into the wall outlet. To disconnect, remove plug from wall outlet.
15. **WARNING: TO REDUCE THE RISK OF FIRE OR ELECTRIC SHOCK, REPAIR SHOULD BE DONE ONLY BY AUTHORIZED PERSONNEL. DO NOT REMOVE THE BASE PANEL. NO USER SERVICEABLE PARTS ARE INSIDE.**

SAVE THESE INSTRUCTIONS FOR HOUSEHOLD USE ONLY

SPECIAL CORD SET INSTRUCTIONS

A short power-supply cord is provided to reduce the risks resulting from becoming entangled in or tripping over a longer cord.

Longer extension cords are available and may be used if care is exercised in their use.

If a long extension cord is used, the marked electrical rating of the extension cord should be at least as great as the electrical rating of the appliance, and the longer cord should be arranged so that it will not drape over the countertop or tabletop where it can be pulled on by children or animals, or tripped over.

NOTICE:

This appliance has a polarized plug (one blade is wider than the other). To reduce the risk of electric shock, this plug will fit in a polarized outlet only one way. If the plug does not fit fully in the outlet, reverse the plug. If it still does not fit, contact a qualified electrician. Do not modify the plug in any way.

INSTRUCTIONS FOR USE

1. Before using your Cuisinart™ Sandwich Grill for the first time, remove all protective paper and wrapping. Remove any dust from shipping by wiping the plates with a damp cloth.
2. Preheat the Sandwich Grill. Close lid and plug cord into a 120V AC wall outlet. The red light will go on to signal power. The green indicator light will go on when unit is ready to use.

Note: The first time you use your Sandwich Grill, it may have a slight odor and may smoke a bit. This is normal, and common to appliances with a nonstick surface.

3. When the green indicator light goes on, place ingredients on bottom plate according to recipes provided. Close the lid and lock it.
4. The green light will go off and the red light will once again illuminate. It may take several seconds for the red light to come on. This is normal.
5. Once the food is ready to eat, the green light will come on again.
6. Remove food by gently loosening the edges with a heat-proof plastic spatula. Never use metal utensils, as they may damage the nonstick coating.
7. Always disconnect the plug from the wall outlet once cooking is completed.

6. Cord Storage (not shown)
- cord wraps under unit for easy storage

Note: The cooking plates of this Cuisinart™ Sandwich Grill have been treated with a special nonstick coating. Before the first use, we suggest you season the grids with cooking spray or oil. If using oil, apply with a paper towel or pastry brush. You may find it helpful to repeat this process before each use of the SandwichGrill.

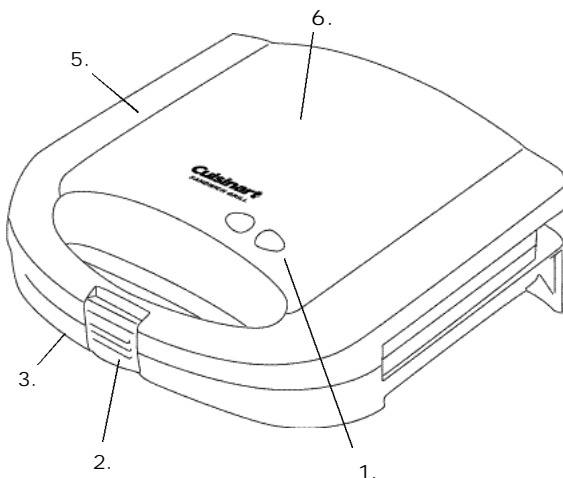

SPECIAL FEATURES

1. Indicator Lights
 - red light illuminates when Sandwich Grill is plugged in
 - green light illuminates when Sandwich Grill is ready to cook
 - green light illuminates again when food is ready to eat
2. Lock Down Lid
 - lock on handle secures contents while cooking
3. Rubber Feet (not shown)
 - will not mark countertop
 - keeps unit steady
4. Nonstick Plates
 - wipe clean after use
5. Brushed Chrome Housing

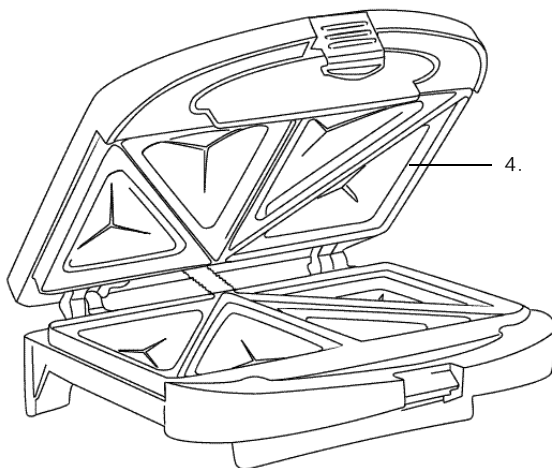

TIPS AND HINTS FOR USING YOUR CUISINART™ SANDWICH GRILL:

Preheat Cuisinart™ Sandwich Grill completely before using. For “quick to assemble” sandwiches and pastries, preheat the Sandwich Grill while preparing the food to be grilled.

Close the lid of the Sandwich Grill while preheating. When preparing more than one batch of sandwiches, keep lid closed to maintain even heat.

You may use a variety of breads in the Cuisinart™ Sandwich Grill with excellent results. Breads that are a “standard” thickness (approximately 1/2-inch) are best for sandwiches, while thicker sliced breads (approximately 5/8 to 1-inch) are recommended for French toast.

For best results, we recommend that the bread be as close as possible to the size of the sandwich plate (5 x 4½ inches). Breads may be trimmed prior to cooking to fit as needed. Bread selections may be hand sliced from whole loaves.

Butter, margarine, and olive oil are recommended for coating the outside of bread when making sandwiches. “Light” versions of margarines are not recommended as they do not withstand heat (check manufacturer’s labels for cooking recommendations for best results).

Have butter or margarine at room temperature when spreading on bread, or melt and apply with a pastry brush.

For best results, moist ingredients such as sliced tomatoes or fruits, pickles, etc., should be blotted or patted dry with a paper towel. Sauces, such as tomato sauce or salsa, can be drained for a short time in a strainer lined with a coffee filter to remove excess liquid.

Use well-drained leftover cooked vegetables or thawed, well-drained frozen vegetables as additions to your sandwiches and omelettes.

Firm textured breads will yield a crispier sandwich than breads with a softer texture.

Use a heatproof rubber spatula or wooden utensil to lift sandwich/pastry/omelette from the Cuisinart™ Sandwich Grill. Avoid using metal utensils, which may mar the nonstick coating of the Sandwich Grill.

For best results, allow hot sandwiches to rest for 2-3 minutes before cutting and serving. The fillings will be

very hot, and will run less if allowed to cool slightly.

Unplug the Sandwich Grill and allow unit to cool completely with lid open before cleaning. When cool, brush excess crumbs from Sandwich Grill with a soft pastry brush, then gently wipe clean with a dampened soft cloth such as one made of microfiber. (Available in most housewares/gourmet stores).

RECIPES

FRENCH TOAST

Makes 4 slices (two servings).

Bread suggestions: thick sliced breads (about 3/4-inch) such as challah, English muffin bread, cinnamon swirl bread, raisin bread

- 2 large eggs, lightly beaten
 - 1/2 cup reduced fat milk
 - 1/2 teaspoon vanilla extract (optional)
 - 4 thick, 3/4 to 1-inch, slices of bread
- Cooking spray or melted unsalted butter

Place the eggs, milk and optional vanilla extract in a small bowl. Using a whisk, beat until smooth. Place the bread slices in a 9 x 9-inch baking dish. Pour the egg mixture into the pan. Turn the bread slices to coat completely and let stand until the liquid is completely absorbed, about 5 minutes. Preheat the Cuisinart™ Sandwich Grill. When the Sandwich Grill is hot (green indicator light will be on), spray lightly with cooking spray or brush with a small amount of melted butter. Place two of the bread slices on the sandwich grids and use firm pressure to close lid and lock. French Toast will be ready when red indicator light goes off and green indicator light comes on. Serve hot with butter or margarine and syrup or preserves, or sprinkle with powdered sugar.

Nutritional analysis per serving:

*Calories 363 (25% from fat) • carb. 50g • pro. 17g
• fat 10g • sat. fat 3g • chol. 221mg • sod. 551 mg
• calc. 191mg • fiber 2g*

SUGGESTED SANDWICHES:

Sandwich fillings can be as limitless as your personal taste and imagination. You may create your own versions of traditional favorites (childhood or diner comfort foods) or combine favorite ingredients to make your own "classics".

To assemble sandwiches, lightly coat one side of each slice of bread (or the outside of a roll, pita loaf or English muffin) with butter, margarine or olive oil. Lay 2 slices of bread, coated side down on work surface. Assemble sandwiches in layers and top with remaining bread, coated side up. Place on preheated Sandwich Grill. Use firm pressure to close lid; lock and cook. Green indicator light will go off and red light will come on (this may not happen immediately). When green indicator light comes on again, sandwich is cooked.

Add 15-30 seconds additional cooking time if a toastier sandwich is preferred. Remove sandwiches using a heatproof plastic spatula. Let sandwiches rest for 2-3 minutes, then cut and serve.

You may even make a French toast batter (without vanilla) and dip the sandwiches in it before grilling to make "croque monsieurs."

Sandwich	Bread/Spread	Filling
Grilled Mozzarella, Tomato & Fresh Basil Sandwiches	Sliced Italian or sourdough Italian bread, hand-sliced artisan bread, panini-type rolls, split pita loaves 3 teaspoons extra virgin olive oil	2-3 ounces mozzarella cheese (regular or fresh), thinly sliced 4-6 large fresh basil leaves, cut into thin shreds 6-8 thin slices fresh ripe tomato, patted dry kosher salt and freshly ground pepper to taste
Hot Grilled Reubens	4 slices rye bread 2-3 teaspoons softened butter or margarine	1½ ounces Swiss cheese (2 slices) 2 ounces thinly sliced corned beef 2 tablespoons sauerkraut, squeezed dry 2-3 teaspoons Russian or Thousand Island dressing 2-3 teaspoons soft butter or margarine
Grilled Cubano Sandwich	4 slices firm white bread or sandwich rolls 2 sandwich rolls 3-4 teaspoons unsalted butter or olive oil	3 ounces thinly sliced roast pork 2 ounces thinly sliced ham 1½ ounces (about 2 slices) Swiss cheese 2 teaspoons yellow or Dijon-style mustard 6-8 thin sliced dill pickle chips, drained
Toasted Chicken Divan Sandwich	4 slices white or wheat bread or 2 pita loaves, split and trimmed to fit sandwich plate 2-3 teaspoons unsalted butter, softened	3-4 ounces diced cooked chicken 4 tablespoons thawed, drained frozen chopped broccoli or leftover cooked chopped broccoli 2 ounces sliced Swiss, cheddar, muenster or Gouda cheese 1-2 teaspoons Dijon-style mustard
Grilled Tuna Melt	4 slices white, wheat or rye bread 2-3 teaspoons unsalted butter, softened	1 small (3 ounce) can water packed tuna, well-drained 2 teaspoons sweet pickle relish 2 teaspoons finely chopped onion 1 tablespoon "light" or regular mayonnaise 2 slices Swiss, cheddar, Monterey Jack, or muenster cheese Combine tuna, relish, onion, and mayonnaise to make tuna salad spread
Toasted Pepperoni Pizza Melt	4 slices white Italian or Italian sourdough bread, or 2 pita loaves, split and trimmed 2-3 teaspoons extra virgin olive oil	2 tablespoons very thick tomato marinara sauce 2 slices mozzarella cheese (about 1/2 - ounce each) 1/4 ounce thinly sliced pepperoni (about 8 slices), cut into shreds

MUSHROOM, PEPPER AND CHEESE OMELETTES

Remember when making filled omelettes, the filling displaces the amount of egg needed. Resist the urge to overfill the omelettes or the egg may run out before it is cooked.

Makes 2 servings

- 2 large eggs
- 1/8 teaspoon baking powder
- kosher salt and freshly ground pepper to taste
- 2 mushrooms (1 inch), cleaned and diced
- 2 tablespoons finely chopped red pepper
- 2 tablespoons shredded reduced fat cheddar cheese
- melted butter or cooking spray

Place the eggs and baking powder in a small bowl. Use a whisk to beat until just frothy; add salt and pepper to taste. When green indicator light comes on, open Sandwich Grill and lightly coat with melted butter or cooking spray. Divide the vegetables evenly among the four quarters of the sandwich grid; sprinkle evenly with the shredded cheese. Pour the egg mixture evenly over the vegetables and cheese. Close the lid and lock. The red light will come on (it may stay green for a few seconds). Cook until the green indicator light comes on again, about 4 – 4 1/2 minutes. Open Sandwich Grill and remove omelettes using a heatproof plastic spatula. Serve immediately.

Nutritional analysis per serving:

Calories 91 (60% from fat) • carb. 1g • pro. 8g • fat 6g • sat. fat 2g • chol. 215mg • sod. 129mg • calc. 55mg • fiber 0g

PLAIN OMELETTES:

Use a whisk to combine 4 large eggs with 1/4 teaspoon baking powder, kosher salt and freshly ground pepper to taste. Preheat Sandwich Grill, butter lightly, and pour egg mixture evenly over the bottom plates. Cook until green light comes on again.

EGG WHITE OMELETTES:

Use a whisk to beat 3 large egg whites with 1/8 teaspoon baking powder. Add salt and pepper to taste. Pour into preheated and buttered/sprayed Sandwich Grill. Close lid and cook until green indicator light comes on again. For a healthy filled egg white omelette, add 2 finely chopped mushrooms,

2 tablespoons thawed and squeezed dry spinach and 1-2 teaspoons grated Parmesan cheese.

FRUIT TARTS

Use your Sandwich Grill to make this quick and easy dessert that can be served plain or topped with ice cream while still warm. Fruit tarts are also a nice alternative to packaged toaster pastries for breakfast.

- 4 slices firm bread – white, wheat, or sweet such as raisin or cinnamon swirl
- 2 - 3 teaspoons unsalted butter, softened
- 4 tablespoons canned fruit pie filling (apple, cherry, peach, blueberry)

Preheat the Cuisinart™ Sandwich Grill. Spread one side of each bread slice with butter. Top the unbuttered side of two slices with half the pie filling each. Cover with remaining bread slices, buttered side up. When green indicator light is on, place the sandwich/tarts on the grids and use firm pressure to close and lock the Sandwich Grill. Cook until the green indicator light comes on again. Remove “tarts” and let cool for about 5 minutes before cutting and serving. (Filling will be very hot.) Serve plain, dusted with powdered sugar, or with a favorite ice cream or frozen yogurt.

Nutritional analysis per serving:

Calories 181 (31% from fat) • carb. 30g • pro. 2g • fat 7g • sat. fat 4g • chol. 16mg • sod. 120mg • calc. 22mg • fiber 2g

FRUIT DANISH VARIATION:

Combine 1 ounce light or regular cream cheese with 1 tablespoon liquid pasteurized egg product (such as EggBeaters®), 1 teaspoon granulated sugar and 1/4 teaspoon vanilla extract and stir until smooth. Spread mixture on unbuttered side of 2 slices of buttered bread. Top each with 2 tablespoons fruit pie filling and remaining slices of bread, butter side up. Place on preheated Sandwich Grill and cook until green indicator light comes on. If using cherry filling, you may also add 1 tablespoon chocolate chips.

CLEANING AND MAINTENANCE

Once you have finished cooking in the Sandwich Grill, remove plug from electrical outlet. Leave top lid open so plates begin to cool.

Never take your Sandwich Grill apart for cleaning. Simply brush crumbs from grooves, and absorb any excess cooking oil or excess fillings by wiping with a dry cloth or paper towel.

You may clean the cooking plates by wiping with a damp cloth as well. This will prevent staining or sticking from build up of oil or fillings. **Be certain plates have cooled completely before cleaning.** If food adheres to plates, simply pour a little cooking oil onto area and let stand approximately 5 minutes, thus allowing to soften for easy removal.

To clean exterior, wipe with a soft dry cloth. Never use an abrasive cleanser or harsh pad. **NEVER IMMERS**
CORD, PLUG OR UNIT IN WATER OR OTHER
LIQUID. DO NOT PUT IN DISHWASHER.

STORAGE

Store with cord wrapped securely around base. For compact storage, stand Sandwich Grill upright on back end. The Sandwich Grill has been designed with a special latch so lid stays closed during storage.

WARRANTY

Limited Three Year Warranty

This warranty is available to consumers only. You are a consumer if you own a Cuisinart™ Sandwich Grill which was purchased at retail for personal, family or household use. Except as otherwise required under applicable law, this warranty is not available to retailers or other commercial purchasers or owners.

We warrant that your Cuisinart™ Sandwich Grill will be free of defects in materials and workmanship under normal home use for 3 years from the date of original purchase.

We suggest you complete and return the enclosed warranty registration card promptly to facilitate verification of the date of original purchase. However, return of the card is not a condition of this warranty.

If your Cuisinart™ Sandwich Grill should prove to be defective within the warranty period, we will repair (or, if we think necessary, replace) it without charge to you. To obtain warranty service, please call our Customer Service Center toll-free at 1-800-726-0190 or write to: Cuisinart, 150 Milford Road, East Windsor, NJ 08520.

To facilitate the speed and accuracy of your return, enclose \$10.00 for shipping and handling. (California residents need only supply a proof of purchase and should call 1-800-726-0190 for shipping instructions.) Please be sure to include your return address, description of the product's defect, product serial number, and any other information pertinent to the return. Please pay by check or money order.

Your Cuisinart™ Sandwich Grill has been manufactured to the strictest specifications and has been designed for use only with authorized accessories and replacement parts. This warranty expressly excludes any defects or damages caused by accessories, replacement parts or repair service other than those authorized by Cuisinart.

This warranty does not cover any damage caused by accident, misuse, shipment or other than ordinary household use.

This warranty excludes all incidental or consequential damages. Some states do not allow the exclusion or limitation of these damages, so they may not apply to you.

Cuisinart

SAVOR THE GOOD LIFE™



Hand
Blenders



Food
Processors



Toaster Ovens



Blenders



Cookware



Mini-Preps

Cuisinart offers an extensive assortment of top quality products to make life in the kitchen easier than ever. Try some of our other countertop appliances and cookware, and Savor the Good Life™.

www.cuisinart.com

©2002 Cuisinart
Cuisinart® is a registered
trademark of Cuisinart

150 Milford Road
East Windsor, NJ 08520
Printed in China

02CU1344

IB-4272