



Bathing has never been like this before. Incorporating exotic woods, acrylic and state-of-the art bathing technologies, the Fuzion™ combines everything you need to create your ideal spa experience.

FEATURES:

- Multi-speed motor
- 2 fully adjustable TheraPro® jets
- 12 directionally adjustable AccuPro™ jets
- 900 watt variable speed heated air blower
- Bottom air channels for maximum massage
- Chromatherapy™ lighting system capable of 256 colors
- Water level sensor
- Drain-assist purge system
- Sculpted armrest and contoured backrest with pillows
- All-in-one electronic control panel
- Infinity-edge drain system
- RapidHeat™ inline heater
- Undermount or choose Wenge or Teak wooden deck
- PrO₃™ Cleansing System

**Fuzion™ 7236
SALON™ SPA with
CHROMATHERAPY**

MODEL NUMBER:
FD85 (Wenge RH)
FD65 (Teak RH)

EXTERIOR DIMENSIONS:
70¹¹/₁₆" long x
35³/₈" wide x 25¹/₄" high

OF JETS/TYPE OF JETS:
2 TheraPro™ Jets
12 AccuPro™ Jets

OPERATING GALLONS:
70 - 94 gallons





Fuzion™ 7236 SALON™ SPA with CHROMATHERAPY

FD85	Fuzion™ 7236 Salon™ Spa, Wenge with Chromatherapy – Right Hand
FD65	Fuzion™ 7236 Salon™ Spa, Teak with Chromatherapy – Right Hand

- Right Hand Drain Locations
- Overflow fitting comes with tub
- Accessories / Hardware:
 - TheraPro™ Jet Rings Kit: #D095
 - BMH 2 Jet trim Kit: # J869
- Trim Kit Finishes Available:
 - (827) – Chrome
 - (898) – Brushed Chrome
 - (815) – Satin Nickel
 - (829) – Bright Brass
 - (805) – Platinum
 - (826) – Brushed Nickel
 - (845) – Oil Rubbed Bronze

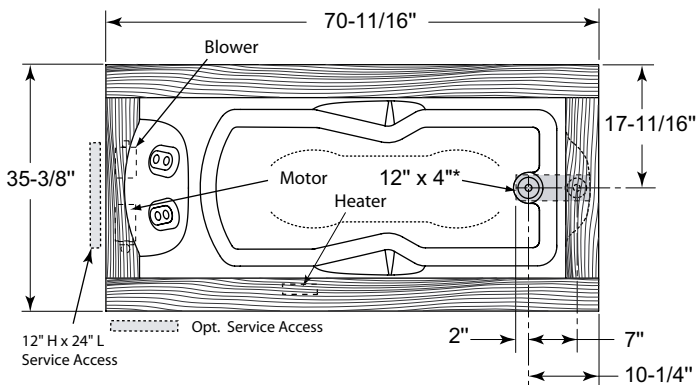

Product Shown: Fuzion™ 7236 Salon™ Spa Teak with Chromatherapy Right Hand Model: FD65

* Measurements inside unit represent cutout in floor to allow for drain/overflow.

Minimum Service Access dimensions given.

INSTALLATION NOTES

Refer to installation instructions included with fixture before beginning installation. Please confirm product availability and specifications before commencing with any installation work.

PRODUCT SPECIFICATIONS AND AVAILABILITY ARE SUBJECT TO CHANGE WITHOUT NOTICE.

Technical Specifications

DIMENSIONS

70-11/16" L x 35-3/8" W x 25-1/4" H
(1795 mm) L x (899 mm) W x (641 mm) H

DRAIN/OVERFLOW

A: 17" (432 mm) B: 10-1/4" (260 mm)

CUTOUT

69-1/2" (1765 mm) x 34-3/8" (873 mm)

TOTAL WEIGHT

1180 lb. (535 kg) / 65.6 lb/ft² (320 kg/m²)

OPERATING GALLONAGE

82 U.S. Gal. (310 Liters)
Min. 70 U.S. Gal. (265 Liters)
Max: 94 U.S. Gal. (356 Liters)

PRODUCT WEIGHT

200 lb (91 kg)

SKIRT MOUNTING

Not Available

ELECTRICAL SPECIFICATIONS

Requires a dedicated GFCI protected separate circuit.

Blower: 120VAC, 20AMP, 60 Hz
Motor/Pump and RapidHeat™: 240VAC, 20AMP, 60 Hz.

HEATER (STANDARD)

Requires a dedicated GFCI protected separate circuit.

RapidHeat™: P/N BN60000

