

cetra® 536 whirlpool plus with integral skirt

from the ancient hymns of the greek gods comes cetra®—italian for “lyre”.



Like its namesake, the Cetra® whirlpool bath is an undeniable classic.

features:

- 4 fully adjustable TheraPro™ jets
- 5 directionally adjustable AccuPro™ jets
- RapidHeat™ in-line heater
- Electronic on/off control with temperature readout
- Air flow adjustability
- Chromatherapy™ lighting system capable of 256 colors
- Sculpted armrest and contoured backrest
- Integral skirt with access panels and built-in tile flange
- PrO₃™ Cleansing System

cetra® 536 plus (with integral skirt)

model number: BP99 – RH, BP93 – LH

exterior dimensions:

60" long x 36" wide x 21 1/4" high

interior dimensions:

41 1/2" long x 22" wide

of Jets/type of Jets:

**4 TheraPro™ Jets,
5 AccuPro™ Jets**

operating gallons:

48 gallons





Cetra® 536 Plus Whirlpool Bath w/Integral Skirt

Model: BP99, BP93

Ordering Information

Product Code:

- BP99 Cetra® 536 Plus Whirlpool Bath with Integral Skirt Right Hand
- BP93 Cetra® Plus Whirlpool Bath with Integral Skirt Left Hand

- Right and Left Hand Drain Location
- Accessories / Hardware:
 - Trip-Lever Drain Kit: #X559
 - Rotary Drain Kit, 26" Cable: #8730
 - TheraPro™ Jet Rings Kit: #D095
 - AccuPro™ Jet Rings Kit (3 Req'd): #P556
- Trim Kit Finishes Available:
 - (827) - Chrome
 - (898) - Brushed Chrome
 - (815) - Satin Nickel
 - (829) - Bright Brass
 - (805) - Platinum
 - (826) - Brushed Nickel
 - (845) - Oil Rubbed Bronze

Installation Notes

Refer to installation instructions included with fixture before beginning installation. Please confirm product availability and specifications before commencing with any installation work.

PRODUCT SPECIFICATIONS AND AVAILABILITY ARE SUBJECT TO CHANGE WITHOUT NOTICE.

Technical Specifications

Dimensions

60" L x 36" W x 21-1/4" H
(1524 mm) L x (914 mm) W x (540 mm) H

Drain/Overflow

A: 18-1/2" (470 mm) B: 9" (229 mm)

Cutout

Not Applicable

Total Weight

742 lb (337 kg) / 50 lb/sq. ft. (242 kg/m²)

Operating Gallonage

48 U.S. Gal. (181 Liters)
Max. 55 U.S. Gal. (208 Liters)

Product Weight

92 lb (42 kg)

Skirt Mounting

Integral

Electrical Specifications

Requires a dedicated GFCI protected separate circuit.

Motor/Pump: 120 VAC, 15 AMP, 60 Hz.

RapidHeat™: 120 VAC, 15 AMP, 60 Hz.

Heater(Standard)

Requires a dedicated GFCI protected separate circuit.

RapidHeat™: P/N S750000

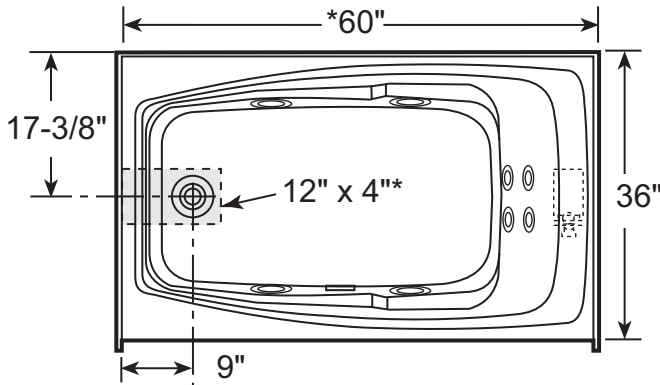

(Left hand shown. Right hand is mirror image.)

Product Shown: Cetra® 536 Plus Whirlpool Bath with Integral Skirt Left Hand Model: BP93

* Measurements inside unit represent cutout in floor to allow for drain/overflow.

