

“The Ultimate Portable Spa”

**Important Operating Instructions
Please Read**



**VOYAGER
CUSTOMER
SERVICE
877-240-9457
M-F 8 to 5 EST**

**OWNERS
MANUAL**



TABLE OF CONTENTS

GENERAL INFORMATION

- Owner's Record and Service Information 1
- Important Safety Instructions 2-3
- Manufacturer's Do's and Don'ts 3

SET UP AND INSTALLATION

- Site Selection 4
- Electrical Requirements and Installation 4
- Packing List 4
- Part Identification Diagram 5
- Assembly Instructions 6-7
- Cover Installation 8
- Step Assembly Instructions 9
(Optional Accessory)

OPERATION

- Connecting the Pump Suction Line 10
- Priming the Pump 10
- Testing the GFCI 10
- Top Side Digital Control 10
 - A. Displaying Time and Temperature 11
 - B. Setting the Temperature & Time 11
 - C. Auto Heat Operation 11
 - D. Jets Operation 11
 - E. Filtration Cycles 12
 - F. Memory 13
 - G. Resetting Your Spa 13
- Air Control Operation 12
 - Jet layout / use / adjustment 12
 - Jet flow control 12
- Safety Features 13
 - A. Freeze Protection 13
 - B. Flow Protection 13
 - C. Overheat Protection 13

MAINTENANCE

- Liner 13
- Cover 13
- Filter Cartridge Removal and Cleaning 13
- Winterizing your Spa 13
- Draining and Disassembling your spa 14
- Water Level 14
- Important Maintenance Procedures 14

WATER MAINTENANCE

- Balancing the Spa Water 15-16
- Water Maintenance DO's and DON'TS 17
- Spa Water Troubleshooting 18-19

SPA TROUBLESHOOTING

- Troubleshooting 20-22
- Service Center Information 22
- Diagnostic Specification Messages 23

SPECIFICATIONS 24

OPTIONAL ACCESSORIES 25

PACK REMOVAL INSTRUCTIONS

- Instructions 26-27
- Part Numbers / Diagram 28

WARRANTY 29

MAINTENANCE LOG 30

Congratulations!

Thank you for the purchase of your new Voyager spa. You are now the owner of the most portable and comfortable spa made.

The Voyager spa has been designed to be simple to own and operate. With a little care, it will give you many years of economical, trouble free use. This manual will guide you through the proper installation and maintenance of your Voyager spa. Please take sufficient time to familiarize yourself with it.

We are always interested in your comments and suggestions. Please share them with us via telephone, letter or e-mail.

Sincerely,

Eric Dormoy,

President

DM Industries, Ltd.

CAUTION

When installing the Voyager spa indoors, use care to install in areas that can withstand exposure to water and are well ventilated.

WARNING

Findings in the "Journal of the American Medical Association" show that women who are planning a pregnancy or are experiencing the first months of pregnancy should avoid hot tubs and saunas. Please consult your physician before using the Voyager spa if you are pregnant or think you may be. For further information, see page 2 and 3.

If you have any questions regarding any of the information on the use and maintenance of your spa, please contact **DM Industries, Ltd.** at **(877) 240-9457 or (305) 908-8187. Mon.-Fri. 8 am-5 pm EST**

Owners Record

Date Purchased: _____

Purchased From: _____

Address: _____

Telephone: _____

Serial #: _____

Serial Number is located on lower right hand side of therapy unit

IMPORTANT SAFETY INSTRUCTIONS

When installing and using this electrical equipment, basic safety precautions should always be followed, including the following:

- 1. READ AND FOLLOW ALL INSTRUCTIONS.**
- 2. WARNING - To reduce the risk of injury.**

Do not permit children to use this product unless they are closely supervised at all times.
- 3.** A grounding wire connector is provided under the motor unit to permit connection of a minimum No. 8 AWG (8.4 mm) solid copper conductor between this point and any metal equipment, metal enclosure or electrical equipment, metal water pipe, or conduit within 5 feet (1.5 m) of the unit.
- 4. DANGER - Risk of injury.**
 - A.** Replace damaged cord immediately.
 - B.** Do not bury cord.
 - C.** Connect to a grounded, grounding type receptacle only.
- 5. WARNING -** This appliance is provided with a Ground-Fault Circuit-Interrupter (located near the end of the power cord). The GFCI must be tested before each use. With the plug connected to the power outlet and with the unit operating, push the test button. The unit should stop operating. Push the reset button. The unit should now operate normally. If the interrupter fails to operate in this manner, there is ground current flowing, indicating the possibility of an electrical shock. Disconnect the plug from the outlet until the fault has been identified and corrected.
- 6. DANGER - Risk of Accidental Drowning.**

Extreme caution must be exercised to prevent unauthorized access by children. To avoid accidents, ensure that children cannot use this spa unless they are supervised at all times.
- 7. DANGER - Risk of injury.** The filter in this spa is sized to match the specific water flow created by the pump. Should the need arise to replace the filter or the pump, be sure that the flow rates are compatible. Never operate the spa if the filter is broken or missing. Never replace a filter with one rated less than the flow rate on the original filter.
- 8. DANGER - Risk of Electric Shock.** Install at least 5 feet (1.5 m) from all metal surfaces. A spa may be installed within 5 feet of metal surfaces if each metal surface is permanently connected by a minimum No. 8 AWG (8.4) solid copper conductor to the wire connector under the motor unit which is provided for this purpose.
- 9. DANGER - Risk of Electric Shock.** Do not permit any electric appliance, such as a light, telephone, radio, or television, within 5 feet (1.5 m) of a spa.
- 10. WARNING - To reduce the risk of injury:**
 - A.** The water in a spa should never exceed 40° C (104° F). Water temperatures between 38° C (100° F) and 40° C (104° F) are considered safe for a healthy adult. Lower water temperatures are recommended for young children and when spa use exceeds 10 minutes.
 - B.** Since excessive water temperatures have a high potential for causing fetal damage during the early months of pregnancy, pregnant or possibly pregnant women should limit spa water temperatures to 38° C (100° F).
 - C.** Before entering a spa the user should measure the water temperature with an accurate thermometer since the tolerance of water temperature-regulating devices varies.
 - D.** The use of alcohol, drugs, or medication before or during spa use may lead to unconsciousness with the possibility of drowning.
 - E.** Persons suffering from obesity or with a medical history of heart disease, low or high blood pressure, circulatory system problems, or diabetes should consult a physician before using a spa.
 - F.** Persons using medication should consult a physician before using a spa since some medication may induce drowsiness while other medication may affect heart rate, blood pressure, and circulation.
- 11. WARNING -** Prolonged immersion in water that is warmer than normal body temperature can result in a dangerous condition known as

HYPERTHERMIA. The causes, symptoms, and effects of hyperthermia may be described as follows: Hyperthermia occurs when the internal temperature of the body reaches a level several degrees above the normal body temperature of 98.6 degrees F. The symptoms of hyperthermia include dizziness, fainting, drowsiness, lethargy, and an increase in the internal temperature of the body. The effects of hyperthermia include: **(1)** unawareness of impending hazard, **(2)** failure to perceive heat, **(3)** failure to recognize the need to exit the spa, **(4)** physical inability to exit the spa, **(5)** fetal damage in pregnant women, and **(6)** unconsciousness resulting in a danger of drowning.

12. WARNING

- The use of alcohol, drugs, or medication can greatly increase the risk of fatal hyperthermia in hot tubs and spas.
- Persons taking medications which induce drowsiness such as tranquilizers, antihistamines or anticoagulants should not use the spa.
- Pregnant women and persons with a medical history of heart disease, circulatory problems, diabetes or high blood pressure should consult their physician before using the spa.
- Children are especially sensitive to hot water. At no time should children have unsupervised access to the spa. The use of elevated decking may encourage children to climb onto the thermal cover – **IT IS NOT DESIGNED AS A SAFETY OR CHILD RESISTANT COVER!** The Voyager comes with a thermal cover which is provided with locking straps. **INSTALL** the locks for your child's safety.

13. SAFETY SIGN

Included with this spa is a safety sign suitable for indoor or outdoor use. The prominent display of this sign is important to occasional users of the spa who should be familiar with these warnings. This sign can be easily attached using the mounting hole in the top of the sign. For additional copies of this sign at no charge, contact the **Voyager Service Center** at **(877) 240-9457** or **(305) 908-8187**

MANUFACTURER'S DO'S AND DON'TS

Reading and understanding these warnings will allow you to reduce the risk of causing inadvertent damage to your spa, your surroundings, or yourself. Read these warnings carefully.

1. **DO** - The water level must be 1" above all jets. The jets can spray water out of the tub if the water level becomes too low.
2. **DO** - Always unplug your motor unit before draining and while filling.
3. **DO NOT** operate without the GFCI located at the end of the power cord. This safety device shuts off the power in a fraction of a second in the event of an electrical short.
4. **DO NOT** use an extension cord to connect the motor unit to the power source. An extension cord will cause a voltage drop which may cause damage to the pump motor and controls.
5. **DO** - Maintain proper water pH (7.4-7.6). The vinyl liner can be damaged by an improper pH balance.
6. **DO NOT** fill the spa through any water softening device as this could damage the liner.
7. **DO** - Place only on surfaces that can withstand the floor loading requirements of your tub. If you do not know the rating of your floor, consult an architect or engineer before filling. See specifications on page 22
8. **DO** - Install the Voyager spa only on floors or areas that can withstand repeated exposure to water (tile, brick, etc.).

WARNING: The use of alcohol, drugs, or medication can greatly increase the risk of fatal hyperthermia.

SAVE THESE INSTRUCTIONS

SET UP AND INSTALLATION

SITE SELECTION

Your Voyager spa is completely self-contained. It can be set up on a patio, deck, and indoor with special consideration.

Structure: The Voyager spa should always be placed on a structurally strong, relatively smooth and level surface. Concrete, bricks, stepping stone or treated wood deck are acceptable permanent surfaces. See specifications on page 22 for loading capacity.

Drainage: Do not place the Therapy module in an area where water will "puddle" around it. A self draining surface sloped 1 inch per 10 feet would be ideal.

Indoor installation

Please give special consideration to the following issues when installing your Voyager spa indoor.

1. Install your spa on water resistant, non-slip floor, preferably with a drain to remove the water that is splashed from the spa. Do not install on carpet or other material that will be damaged by moisture.
2. Take into consideration the room humidity which will exist due to high temperatures. Providing natural or forced ventilation in the room will help maintain comfort and minimize moisture damage to the surrounding environment and remove chemical odor in the air.
3. Indoor second story above finished living space should be avoided due to the possibility of water and humidity damage.
4. Allow full access to the spa equipment for service.

Outdoor Installation

Please take into account the following when considering outdoor installation.

1. Local Building Codes.
2. Provide a smooth surface (tile, concrete, wood, brick or sand) and verify that there are no sharp objects under the spa prior to set up.
3. Place your spa away from areas where debris and dirt may be tracked into the spa.
4. Consider privacy, sun exposure, and wind shielding. A sheltered environment can result in lower operating and maintenance costs.
5. It is recommended that the spa be placed in a location where it can be easily supervised when in use by children.

ELECTRICAL REQUIREMENTS AND INSTALLATION

Allow easy access to the Ground Fault Circuit Interrupter (GFCI) which is located on the end of the power cord. The 110 Volt GFCI and the outlet it is plugged into should be protected from extreme weather, landscape sprinklers and accidental spills.

A pressure clamp wire connector is provided in the underside of the pump motor to permit connection of a minimum No.8 AWG (8.4mm) solid copper bonding conductor between this point and any metal equipment, metal enclosures or electrical equipment, metal water pipe or conduit, within 5 feet (1.5m) of the unit as needed to comply with local requirements.

Your Voyager spa has been carefully engineered to provide maximum safety against electrical shock. Installation must be within 15 feet of a three wire grounded 110V 15A outlet. The outlet should be a minimum of 5 feet from the spa. Connecting the Voyager spa to an improperly wired circuit, or using an extension cord may cause damage to the equipment that is not covered under warranty.

PACKING LIST

BOX TYPE	QUANTITY	CONTENT
A	1	1 Therapy Module 1 Floor Pad
B	3	Each Box contains 2 Wall Sections 2 Connecting Rods
C	3	Each Box contains 2 Seats
D	1	Accessory Parts

- Subject to Change -

KEEP THE THERAPY MODULE'S ORIGINAL BOX. IT WILL BE NEEDED TO SHIP THE MODULE TO A WARRANTY STATION OR THE FACTORY IN THE UNLIKELY EVENT THE MODULE NEEDS SERVICING.

PART IDENTIFICATION DIAGRAM

1. Therapy Module (side view)
2. Therapy Module (front view)
3. Spa
4. Spa Cover
5. Correct Outlet Types:
 Outlet A—15 Amp 115 Volt
 Outlet B—20 Amp 115 Volt

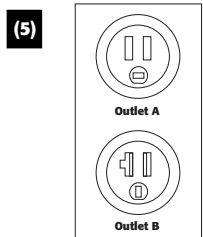
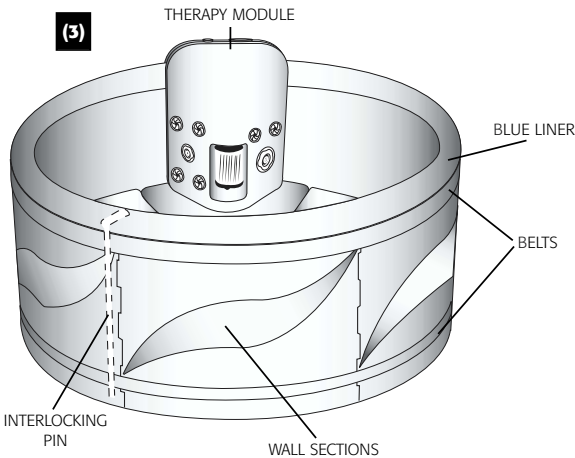
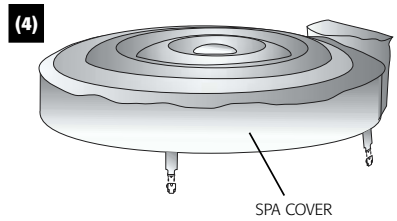
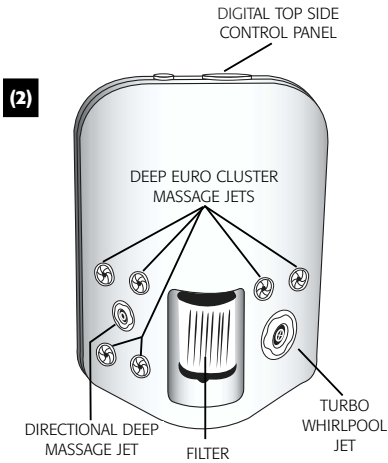
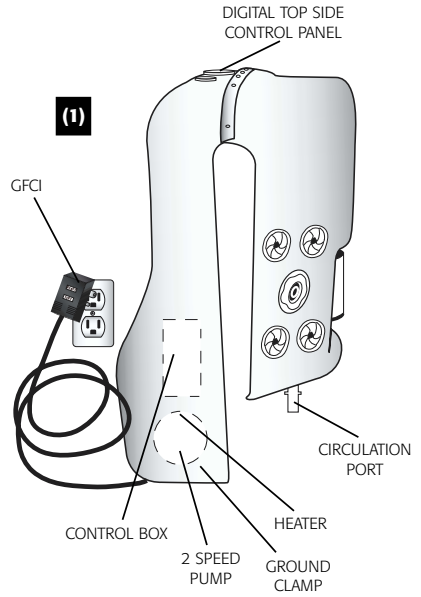

ASSEMBLY INSTRUCTIONS

1. PLACE BOTTOM PAD on a clean, smooth, level surface.
Please see **SITE SELECTION: Structure** on page 4.

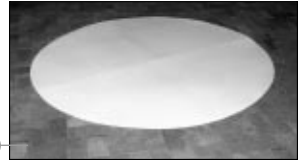

2. STRETCH OUT LINER. If liner is stiff, warm in the sun.

3. SET UP WALLS and install locking pins.

4. INSTALL THE LINER

- a) Note that the liner has a patterned side. Place the liner so that the patterned side faces the inside of the spa.
- b) Note that the therapy module, the liner seam, the belt spindles, and the seat with the punched hole, need to be aligned for the therapy module to cover the seam and the belt spindles and for the cover straps to fall in the center of the wall sections. All seats have a knock-out whole. Use a screwdriver to remove the hole cap in the seat that will be located under the therapy module.
- c) Choose location of the therapy module, taking into consideration accessibility and electrical requirements. Refer to **SITE SELECTION** on page 4.
- d) Place the liner seam in the center of the wall section you would like to put the therapy module on.
- e) Stretch the liner over the top rim of the spa. Stretching the liner into its final position will take about five minutes and may require three or more persons.

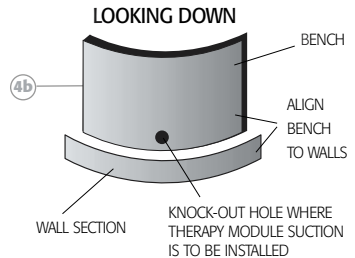
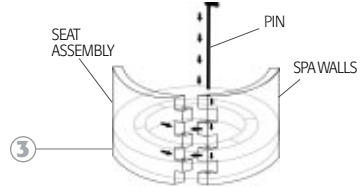

5. INSTALL THE TOP BAND locating the belt spindle at the liner seam. Inline with only the seat suction hole.

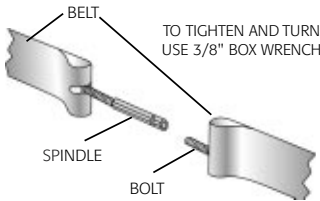

6. INSERT THE SEATS, aligning the seat with the punched hole with the liner seam. To assist in the installation of the seats, it may be necessary to position 2 seats like a pyramid (see diagram below). Gently press down on the apex and they will all register in place.

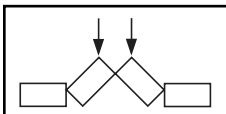

7. INSTALL THE BOTTOM BELT aligning the belt spindle with the top one.

IMPORTANT: THE SPA WALLS AND INTERLOCKING PINS HAVE NOT BEEN DESIGNED TO SUPPORT THE WEIGHT OF THE WATER OVER EXTENDED PERIODS OF TIME. THE BANDS MUST BE INSTALLED TO PROVIDE THE STRUCTURAL AND LOAD SUPPORT TO THE SPA WALLS. FAILURE TO INSTALL THE BELTS COULD CAUSE TEARING AT THE WALL HINGES AND WILL VOID THE WARRANTY.

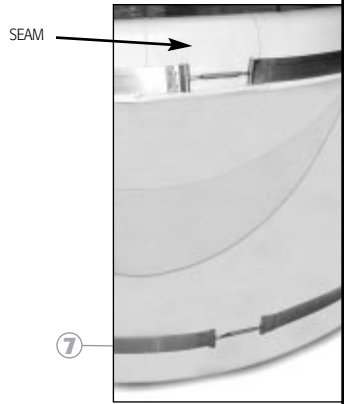

8. PLACE THE THERAPY MODULE over the wall, the belt spindles and the seat with the punched hole. When placing the module, make sure the inside lower edges of the module are kept away from the liner to prevent tearing it.

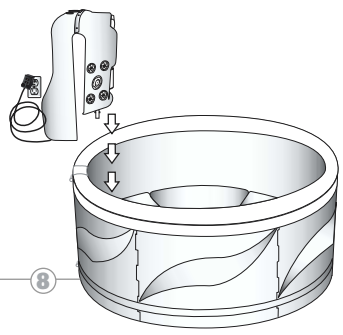
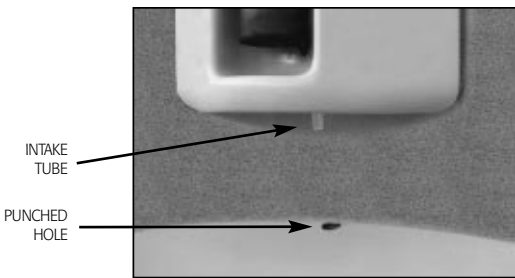

9. FILL UP SPA and follow the instructions listed in "Initial Start Up Procedures."

DO NOT PLUG IN THE THERAPY MODULE UNTIL THE SPA HAS BEEN FILLED AND PRIMED PROPERLY.



COVER INSTALLATION

1. Inflate cover with air pump provided. **Do not over inflate.**
2. Place cover on filled spa. Be sure it is correctly positioned.
3. Position the tie-down hardware on the side of the spa so that they are easily reached by the cover tie-down straps.
4. Allow for about a 1/2" to 3/4" slack in the tie-down strap to make it easy to insert the strap into hardware and to compensate for vinyl shrinkage in cold weather.
5. Attach hardware with screws provided.
6. Keep cover fastened down at all times when not in use. The cover locking hardware may be locked with a key (provided).

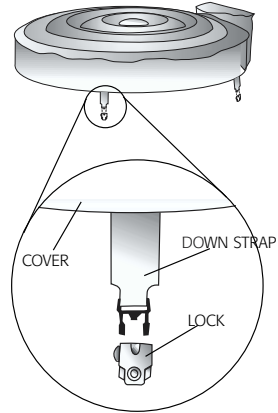

CAUTION: FAILURE TO FOLLOW THE ABOVE INSTRUCTIONS MAY RESULT IN INJURY OR DROWNING. DO NOT STAND, SIT OR LIE ON OR PERMIT ANY HEAVY WEIGHT TO REST ON THE COVER. THE INFLATABLE COVER IS NOT A FLOATATION DEVICE AND IS MADE AS AN INSULATING DEVICE AND SHOULD NOT BE USED FOR ANY OTHER PURPOSE.

Never cover your Voyager with a transparent plastic covering. The UV rays from the sunlight may cause your liner to change color and shorten its life.



STEP ASSEMBLY INSTRUCTIONS (Optional Accessory)

Parts Check List:

- (2) Side Panels
- (2) Step Treads (one curved, one straight)
- (1) Strip of Foam Squares

1. USING SHARP KNIFE, carefully cut the two locking wedges off the ends of the steps and save. (see figure 1).

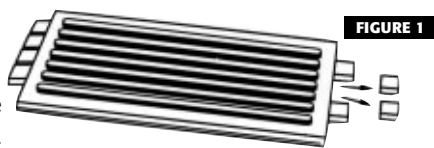

2. LAY ONE OF THE SIDE PANELS DOWN. Push the end of the step into the openings on the side panel making sure the front edge of the step is flush with the front edge of the side panel. Repeat for second step. (See figure 2)

Note: top step is curved.

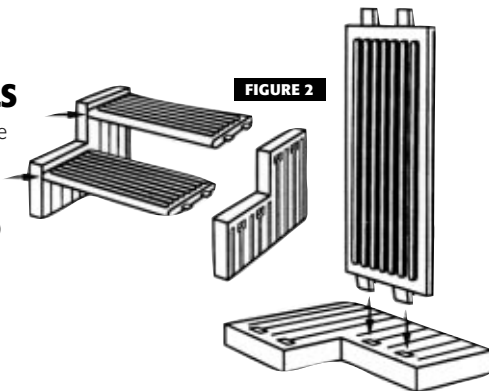

3. SECURE EACH STEP by tapping a locking wedge in between the side panel and the top surface of the step. (See figure 3).

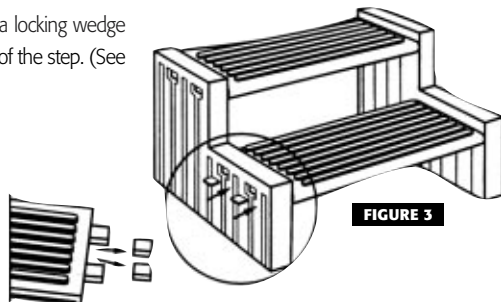

4. PEEL OFF A FOAM SQUARE and apply one to each of the bottom four corners to prevent the step from slipping. (See figure 4).

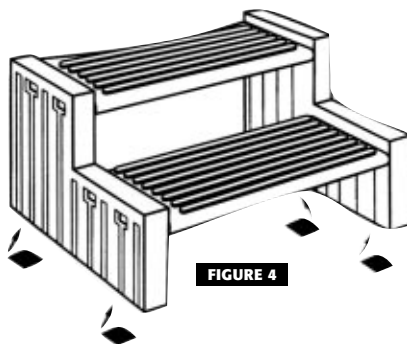

OPERATION

CONNECTING THE PUMP SUCTION LINE

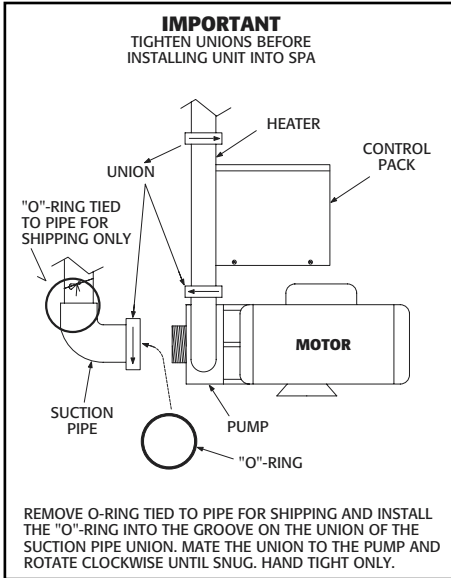

PRIMING THE PUMP

1. Fill the Voyager till the water is approximately 4" over the jets. Do not overflow.
2. Remove the access door from the module and locate the priming hose system.
3. Remove the valve cap.



Note: the priming valve has an open (inline), closed (across) valve handle.



4. Attach by threading onto the priming valve the male to male hose adapter.
5. Connect your garden hose to the adapter.
6. Open priming valve (inline position) and start the water flow from your hose.
7. Plug in the voyager GFCI protected cord and follow start up and programming directions.
8. Once the pump "starts" and you note a continuous flow of water at the jets-the Voyager priming phase is complete.
9. Shut off water to hose.
10. Close (across position) prime valve handle.
11. Replace valve cap.
12. Store for future use the adapter.

TESTING THE GFCI

Plug in the Ground Fault Circuit Interrupter (**GFCI**) into a standard 110V-15A outlet (See correct type of outlets on page 5).Now is a good time to test the **GFCI**. Please do so as follows:

The GFCI is a very important safety device. The **GFCI** shuts off the electricity in a fraction of a second if there is a short anywhere in the system. The **GFCI** plug fits conventional 110V outlets. It is recommended that the **GFCI** be tested prior to each use. Test as follows:

REMINDER: DO NOT USE AN EXTENSION CORD. DOING SO MAY CAUSE DAMAGE THAT WILL NOT BE COVERED UNDER THE WARRANTY.

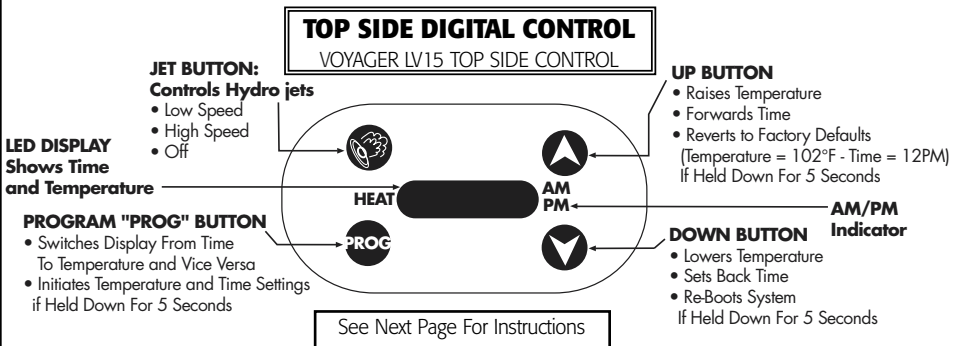

1. Push the **TEST** button on the **GFCI**. The **RESET** button will trip out, the **GFCI** indicator window will turn white and the top side digital control LED display will go out. If this does not happen, **DO NOT USE THE VOYAGER. CALL DM INDUSTRIES LTD'S SERVICE CENTER FOR ASSISTANCE.**
2. If the **GFCI** tests properly, firmly push the **RESET** button back into place. The **GFCI** indicator window will turn red and the top side digital control LED display will come back on. If this does not happen, **DO NOT USE THE VOYAGER. CALL DM INDUSTRIES LTD'S SERVICE CENTER FOR ASSISTANCE.**
3. If the **GFCI** trips by itself at any time, firmly press the **RESET** button back into place and perform the above tests. If this happens more than once, **DO NOT USE THE VOYAGER. CALL DM INDUSTRIES LTD'S SERVICE CENTER FOR ASSISTANCE.**

Once the Voyager is properly powered, the digital control will start the pump after a few seconds and water should start flowing through the jets. If no water is coming through, unplug the **GFCI** and repeat the priming procedure or see the trouble shooting chart on page 18.

Your Voyager spa has been designed to be simple to operate and maintain. It is equipped with state-of-the-art digital control with LED readout (see previous page) to show temperature and time. The digital control has been factory programmed for your convenience. Once properly connected, the filtration pump and heater will automatically come on and heat the spa to 102.

A. Displaying Time or Water Temperature.

Pressing the "PROG" button will switch the display between time and water temperature.

B. Setting Temperature and Time

1. Press and hold down the "PROG" button for 5 seconds until the display starts flashing. Note that the display will be flashing during this procedure.
2. Press the "UP" or "DOWN" arrow to select the desired temperature.
3. Press the "PROG" button to show the "Hours".
4. Press the "UP" or "DOWN" arrow to select the current hour. Note the AM and PM indicators.
5. Press the "PROG" button to show the Minutes.
6. Press the "UP" or "DOWN" arrow to select the current minute.
7. Press "PROG" button to exit the programming mode or wait 30 seconds for normal display to appear

C. Auto Heat Operation.

Your spa is equipped with a 2-speed pump. The low speed operates during filtration and heating cycles. Your selected water temperature will be maintained automatically 24 hours a day. The electronic thermostat will monitor your water temperature at the top of each hour by cycling the low speed pump for 2 minutes. If the spa water temperature is below the set temperature, the heater will be activated until the water temperature reaches the set temperature, at which point both low speed pump and heater will turn off. If the water temperature is at the set temperature, the low speed pump will turn off at the end of the 2 minutes.

The spa water will heat at about 2 deg F per hour. Your selected water temperature will be maintained 24 hours a day. The maximum temperature is set at 104° F. Note that the heater will turn off when you are using the spa on therapy mode (Hi-speed of the pump). The heater only operates on low speed.

In case of an electrical power failure or if you disconnect your spa, the selected temperature and current time will be stored in memory. Once the power is restored, your spa will continue to operate as per your original choice. The time setting will obviously have to be corrected.

D. Jet Operation

The Voyager is equipped with a 2-speed or 2-mode therapy pump. The soft-mode (low speed) provides soft Relaxation Therapy and the power mode (hi-speed) provides vigorous Power Therapy.

JET Button:

1. Press "JET" to activate the Relaxation Therapy mode. (Low speed pump).
2. Press "JET" a second time to activate the Power Therapy mode. (High speed pump).
3. Press "JET" a third time to turn the pump off.

Note that the heater will turn off during therapy mode (hi-speed) to allow the spa to continue to operate on 15A 110V outlet. For safety, all jet modes will automatically turn off after 30 minutes. If needed, reactivate any therapy mode as indicated above. Remember that the low-speed mode is also controlled by the thermostat and the filtration cycle timer. The low-speed pump will remain on if the thermostat calls for heat or if you are operating the spa during the auto filtration cycle (8am to 11am & 4pm to 7pm).

ALWAYS CHECK THE WATER TEMPERATURE PRIOR TO ENTERING INTO YOUR SPA.

E. Filtration Cycles

Your spa digital control has an electronic timer that has been pre-programmed to automatically run the filtration low speed pump 3 hours twice a day for a total of 6 hours, from 8am to 11am, and from 4pm to 7pm. The heater will come on as needed during those hours. Note that filtration will also be provided during the heating cycles, when the spa electronic thermostat starts the low speed pump and the heater to maintain the desired temperature.

F. Memory

The temperature setting that is entered into your spa digital topside control are permanently retained in its solid state memory. In the event of a power failure, the temperature setting will be captured and held until power returns. The temperature setting at the time of the power failure will be restored when power returns.

G. Resetting Your Spa

Like your PC at home, your spa electronics could get corrupted by electrical surges or other interference resulting in improper operations. To properly reset or reboot your spa, unplug the GFCI and plug it back in after 5 full minutes. Then press and hold the "UP" arrow button for 5 seconds. The topside display will show 12:00 PM as soon as you release the "UP" button and the temperature will be reset to 102°F, indicating a successful system reset.

AIR CONTROL OPERATION

AIR CONTROL OPERATION - Open to regulate air to jets. When finished with spa, return pump to low speed. Close so air induction does not fight the heater.

JET LAYOUT / USE / ADJUSTMENT - All jets have flow control "dial" adjustment. By rotating the jet face, changing the combination of jets, and adjusting to what extent they are open or closed, you have the ability to "customize" each bank of jets to your individual hydro-massage needs of flow and pressure.

Remember, as you turn off or reduce the flow of water out of one jet, you also increase the pressure and flow through the others. An important feature of this jet adjustment ability, is to enhance specific water currents in the Voyager Spa. For example, if you shut off one entire bank or jet side of the module and open the other, you can create a "true" whirlpool effect in the spa within a few minutes.

Remember that the Voyager has a 2 speed pump. You can further vary the massage and water current sensations by changing speeds which changes the amount of water flow through the jets.

This is also true of the air control / jet relationship.

IMPORTANT: Always leave at least 2 jets on or opened so that the pump is not back-pressured. When finished with the use of the spa, put the pump into low speed and close the air control.

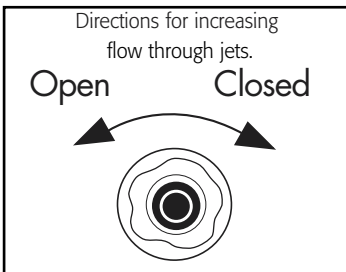
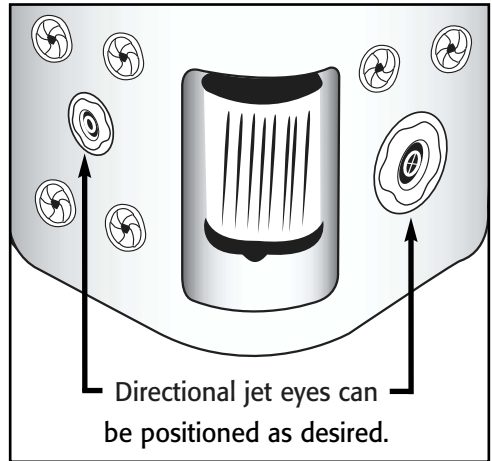

SAFETY FEATURES

A. Freeze Protection

If the temperature in the spa plumbing falls below 50 degrees Fahrenheit (10 degrees Celsius), the water pump will turn on low speed and run for one minute. After one minute, if the water is still at 50 F, the heater will turn on and raise the temperature 10 Degrees. The top side control will display the message "ICE" to indicate potential freeze conditions.

B. Flow Protection

If the flow of water through the heater is insufficient, the spa controller will automatically turn off the heater to prevent overheating. The display will show "FLO", indicating a flow restriction caused by a clogged filter or pump impeller, a malfunction of the pressure switch or a defective pump motor. Refer to the Trouble Shooting Chart. If you cannot pinpoint the cause, Call DM Industries Ltd's Service Center for technical assistance.

C. Overheat Protection.

If a malfunction occurs and the spa water temperature reaches 112F, the pump and heater will turn off. **DO NOT ENTER THE WATER.** Remove the cover and allow the water temperature to cool down to 104 F. Reset the system using the procedure on page 11, section G: **Resetting Your Spa.** The pump and heater will start normal operation when the water temperature reaches 104F. If this happens a second time in a row, **UNPLUG THE SPA AND CALL DM INDUSTRIES SERVICE CENTER FOR ASSISTANCE.**

If there is an overheat condition in the spa heater, the display will show the message "HILI". **DO NOT ENTER THE WATER.** Remove the cover and allow the water to cool down to 104F. Then reset the system by holding down the "DOWN" button for 5 seconds. If the "HILI" message returns, **UNPLUG THE SPA AND CALL DM INDUSTRIES LTD'S SERVICE CENTER FOR ASSISTANCE.**

MAINTENANCE

LINER

Your spa liner will last many years when properly used and maintained. The primary cause of failure is the improper care of the water. A regular program of water treatment as outlined in "Important Maintenance Procedures" is essential. Avoid a low pH, as this will cause unsightly wrinkles to form in the liner.

Cleanliness - Empty your voyager and refill with clean water every 2 to 3 months or when it becomes

cloudy and proper water chemistry does not clear it up. While empty, use a mild non-foaming soap solution or mild detergent to wipe away any soil or stains on the liner. Rinse thoroughly before refilling the spa. Do not use cleaning aids such as steel wool, stiff bristle brushes or abrasive cleaners.

Storage - Always dry the liner if you want to move the Voyager or store it for a period of time. It is recommended to store the liner in a warm dry place.

Repair - If your liner gets torn or punctured, a repair Vinyl Kit can be bought from your retailer or obtained by calling DM Industries Ltd.'s Service Center. A secure, unnoticeable repair can usually be made.

COVER - Fading and discoloration will occur with extended exposure to the sun and water chemicals. This will not affect its integrity and its insulation value. We recommend to clean the cover monthly to maintain its original appearance. Just hose it down and scrub it using a sponge with a mild soap solution. Rinse it thoroughly and let it dry prior to placing it back on the spa. If your cover is punctured, repair it with the repair kit provided.

Filter Cartridge Removal and Cleaning

Clean your filter every 4 to 6 weeks depending on usage. Turn the spa off by unplugging the GFCI and proceed as follows:

1. Remove the filter by pulling it down.
2. Rinse the filter using a garden hose. Rotate and separate the filter pleats while spraying water to remove all debris possible. Let the filter dry and then look for calcium deposits (scaling) or an oil film. If you find these, you will need to deep clean the filter cartridge with a filter cleaning solution to break down and remove mineral deposits and oils. The filter cartridge should be replaced with a new cartridge every 6 to 9 months.
3. Place the filter cartridge back by pushing it upward into its adapter. It is recommended to have a second filter as spare part. Filter cartridges and cleaning solutions are available at your retailer.

Winterizing your Spa.

The Voyager is designed to be operated year round. If you decide not to use your spa during the winter or during an extended period of time, it is recommended to disassemble it and store it in a dry and warm place. Remember to clean and dry the liner as outlined previously.

If you decide to keep and use your spa outside during the winter, keep it at the desired temperature, making sure to keep the cover on. The added "**Freeze Protection**" safety feature will insure a safe operation.

MAINTENANCE

Caution must be used with the latter approach. In the event of electrical power interruption, regardless of the cause, the heater and pump will stop operating and freeze protection will be lost, possibly resulting in freeze damage to the Therapy Module.

Draining and Disassembling your Spa

Empty and clean your Voyager spa every 2 to 3 months. Unplug the GFCI and proceed as follows:

1. Use a hose to siphon the water or a submersible pump. Make sure not to allow the suction end of the hose or the submersible pump to contact the vinyl. This may cause damage to the liner not covered under the warranty. Note that you can utilize one of the jets to prime a garden hose. Place the hose in

front of a jet until the water starts coming out of the other end. Place the hose at the bottom of the spa and unplug the GFCI immediately.

2. Remove the Therapy Module and loosen the lower union nut of the pump. All the water remaining in the module will run out.
3. Disassemble the rest of the spa by reversing the Assembly Instructions outlined on page 6.
4. Store your spa in a dry and warm place.

Water Level

Always keep the water level about 1" above the highest jet. This will ensure that the jets will not spray water out of the spa.

IMPORTANT MAINTENANCE PROCEDURES

DAILY

3 days a week

Check water level. Keep water 1" above the highest jet.

Check and adjust chlorine level to 1.0 to 3.0 ppm if chlorine is used as sanitizer. If Bromine is used, check weekly. Sodium dichlor is the recommended type of sanitizer.

WEEKLY

Once a week

Test the spa water using 3-way water test strips

Adjust pH and total alkalinity. PH: 7.4 to 7.6 (ideal 7.6). Total Alkalinity: 80 to 120 PPM

Maintain 1.0 to 3.0 ppm bromine or free chlorine.

Add 1 ounce of SPA DEFENDER to prevent calcium build up. Calcium hardness: 50 to 150 ppm.

Shock treat with 2 ounces of RENEW, a non chlorine shock

MONTHLY

Four to six weeks

Inspect and clean the spa filter cartridge. It is very important to maintain your spa filter cartridge and keep it clean and free of particles which can restrict water flow. If the filter is not cleaned on a regular basis, the filter may clog and restrict water flow, which causes improper filtration and poor jet performance. See "Filter Cleaning" instructions.

Two to three months

Drain your spa. Follow the procedures outlined in "Draining Your Spa" page 12 and clean it following the procedures in "Cleaning The Spa Liner" page 11. When refilling your spa, be sure to follow the procedures outlined in "Priming the Pump" page 8 and in "Balancing Your Spa Water" page 13-14.

WATER MAINTENANCE

BALANCING THE SPA WATER

Water treatment is an important factor in the enjoyment of your Voyager. Proper water sanitation is essential for the health of your friends, family as well as permitting years of trouble-free use of your spa. The most common water chemistry problems that can damage your spa liner are:

1. Improper pH maintenance. pH balance is critical to proper water maintenance. Too low of a pH level will result in excessive wrinkles and damage of the vinyl liner as well as corrosion in the Therapy Module.
2. Not pre-dissolving chemicals before adding to the water.
3. Use of improper chemicals.
4. Over chlorination. Sodium dichlor is the recommended type of sanitizer. Sodium dichlor dissolves easily and has a neutral pH, which minimizes the effect that the addition of a sanitizer has on the pH balance. Trichlor compounds are not recommended because they have a very low pH, are very potent and difficult to dissolve.

BALANCING YOUR SPA WATER

The instructions below will assist you with balancing the spa water for the first time. You will need the following items to balance your spa water.

1. "3-WAY TEST STRIPS"
2. "PH-UP" and "PH-DOWN" for pH control.
3. "MINERAL SURFACE PROTECTOR" for Calcium and Scale control.
4. "METAL INHIBITOR" for breakdown of mineral deposits.
5. "POTASSIUM PEROXY MONOSULFATE" for shock treatment.
6. "BROMINE" or "CHLORINE" for sanitizing the spa water.

Please read "WATER MAINTENANCE" then follow these easy steps:

1. Fill your spa until the water level is 1" above the highest jet. It is **NOT** advisable to use softened water in your spa, as it may be corrosive.
2. Add a 1/2 pint of Spa Metal Inhibitor to prevent iron or copper deposits from staining the finish of your spa. If your water is known to contain high concentrations of these metals it may be necessary to add an additional quantity of Spa Metal Inhibitor.

3. Use a 3-Way Spa Water Test Strip or test kit to measure the pH and Alkalinity of your water. The following instructions utilize test strips for testing. Immerse the test strip in the spa water, following the instructions on the test strip container label. Compare the test strip to the label to determine the condition of the spa water.

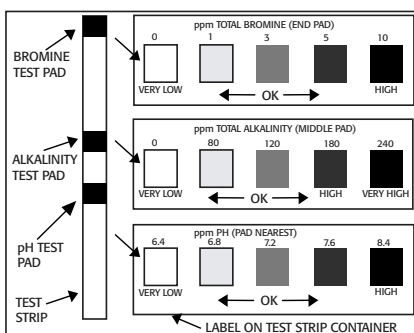

4. If the Alkalinity is not within the acceptable range (80 to 120 ppm) it should be adjusted first. If it is low, raise the alkalinity by adding PH-UP 1 oz. at a time, retesting until the alkalinity reaches 120 ppm. If the alkalinity is high, it should be lowered by using PH-DOWN 1 oz. at a time.
5. After the alkalinity is properly adjusted, the pH is next. If the pH is above 7.8, use PH-DOWN (1 oz. at a time) to lower it to the acceptable range. If the pH is below 7.2, add PH-UP to bring it into the acceptable range. It is extremely important to NEVER allow the pH of your spa water to be under 7.0, as this can severely damage your equipment and will void the warranty.
6. Add Sanitizer, either chlorine or bromine. For Chlorine: Follow the directions on the bottle. Chlorine dissolves rapidly; you should get a reading on the test strip within minutes of application. For Bromine: Follow the directions on your floating brominator. It is necessary to add sodium bromine only when the spa is being filled. Bromine tablets erode slowly, and it may take several hours before you will get a reading on the test strip. It may be necessary to adjust the floating brominator.
7. To properly maintain the chemical balance of your spa, follow the 3 day a week program outlined in page 12.

BALANCING THE SPA WATER

3 DAY A WEEK SPA CARE PROGRAM

MONDAY

1. TEST THE WATER USING "3-WAY SPA WATER TEST STRIPS".
2. Adjust pH and total alkalinity - Refer to pH and total alkalinity on label of "PH-UP" and "PH-DOWN".
3. Maintain **1.0 to 3.0 ppm** Bromine or free Chlorine.
4. Add 1 ounce of "METAL SURFACE PROTECTOR" to prevent calcium build up.
5. Shock treat with 2 ounces of "POTASSIUM PEROXY MONOSULFATE", a non-chlorine shock, every week as needed.

WEDNESDAY

1. Nothing required if Bromine is used as sanitizer. Check and adjust Chlorine level if Chlorine is used.

FRIDAY

1. Nothing required if Bromine is used as sanitizer. Check and adjust Chlorine level if Chlorine is used.

Note: The above table is an example only. Actual spa usage will determine the amount of chemicals required to maintain proper chemical balance.

ALKALINITY

VERY LOW	0	ADD SODIUM BICARBONATE TO INCREASE
ACCEPTABLE ZONE	80	IDEAL
	120	
HIGH	180	ADD SODIUM BISULFATE TO DECREASE
VERY HIGH	240	

pH LEVEL

TOO ALKALINE	8.4	ADD pH DECREASER TO LOWER pH
SCALING ZONE	8.2	
	7.8	
COMFORT ZONE	7.6	IDEAL
	7.4	
	7.2	
TOO ACIDIC	7.0	
CORROSIVE ZONE	6.8	ADD pH INCREASER TO RAISE pH

SANITIZER LEVEL

ppm	DO NOT USE SPA UNTIL TEST KIT READING IS BELOW 5.0 ppm
5.0 -	
4.0 -	RECOMMENDED LEVEL
3.0 -	SAFE
2.0 -	
1.0 -	DO NOT USE SPA
0 -	ADD SANITIZER TO REACH RECOMMENDED LEVEL

WATER MAINTENANCE DO'S AND DON'TS

DO Add all chemicals slowly with the hydro jets operating in high speed.

DO Use care when handling chemicals.

DO Store granulated chlorine in a cool, dry place to maintain the chlorine's freshness. Granulated chlorine will degrade if stored improperly or for a long period of time. Do not store in sunlight.

DO Maintain total alkalinity level within the recommended range of 80 to 120 ppm. The calcium hardness level should be maintained in the 120 to 250 ppm range.

DO Maintain the pH level within the recommended range of 7.4 to 7.6.

DO Maintain proper chemical balance to reduce the risk of catching or spreading infection.

DO Use granulated chlorine/bromine produced specifically for portable spas.

DO NOT Use swimming pool chemicals in your spa.

DO NOT Use household bleach (liquid sodium hypochlorine).

DO NOT Use swimming pool (muriatic) acid to lower pH. Many swimming pool water care products can cause damage to spa liner and equipment.

DO NOT Allow anyone to be in the spa while chemicals are being added or dissolving.

DO NOT Use incorrect products such as Trichlor, which has a very low pH (2.6), dissolves very slowly, is highly concentrated, and was designed for concrete or plaster swimming pools. It will cause damage to your spa!

CHEMICAL SAFETY INSTRUCTIONS

When using chemicals, read labels carefully and follow directions precisely. Though chemicals protect you and your spa when used correctly, they may be hazardous in a concentrated form. Observe these guidelines:

DO Accurately measure and use the exact quantities specified, never more.

DO Handle all containers with care. Store in a cool, dry, well ventilated place.

DO Keep chemical containers closed at all times when not in use. Replace caps on proper containers.

DO Allow only a responsible person to handle spa chemicals. Keep them out of the reach of children.

DO Follow the emergency advice on the product label in case of accidental contact, or if the chemical is swallowed. Call a doctor or local Poison Control Center. If a doctor is needed, take the product container along so that the substance can be identified.

DO NOT inhale fumes or let chemicals come in contact with your eyes, nose or mouth. Wash your hands after use.

DO NOT Let chemicals get on surrounding surfaces or landscaping. Don't use a vacuum cleaner to clean up chemical spills.

DO NOT Smoke around chemicals. Fumes may be highly flammable.

**DO NOT USE HYDROGEN PEROXIDE
OR HYDROCHLORIDE BASE CHEMICALS.**

SPA WATER TROUBLESHOOTING

SYMPTOM	PROBABLE CAUSE	SOLUTIONS
Cloudy Water	Inadequate filtration/dirty filter	Clean filter with a filter cleaner or degreaser.
	Excessive oils/organic matter	Shock the spa with "POTASSIUM PEROXY MONOSULFATE".
	Improper sanitation	Increase sanitizer to recommended level.
	High pH and/or high alkalinity	Adjust pH; add "PH-DOWN".
	Suspended particles/organic matter	Use clarifier.
	Overused or old water	Drain the spa, clean and refill.
Water Odor	Excessive organics /too many chloramines/ bromamines - insufficient free available chlorine	Shock the spa with "POTASSIUM PEROXY MONOSULFATE"
	Improper sanitation	Increase sanitizer level to recommended level.
	Low pH	Raise pH with "PH-UP".
Chlorine Odor	Too many chloramines-insufficient free available chlorine	Shock the spa with "POTASSIUM PEROXY MONOSULFATE"
	Low pH	Adjust pH; raise pH with "PH-UP"
Musty Odor	Bacterial or algae growth	Shock the spa. If problem is visible, draining and cleaning may be required.
Foaming	Buildup of body oils, lotion and chemicals resulting in soap or detergent	Add defoamer; or drain and refill.
	Overused or old water	Drain and refill.
	Excessive organics	Shock with "POTASSIUM PEROXY MONOSULFATE".
Organic Buildup/ Scum Ring Around The Tub	Body oils and dirt	Wipe off scum with a clean rag or use mild detergent. If needed, drain, refill spa, and adjust water.
	Inadequate filtration	Clean filter with a filter cleaner or degreaser.

SYMPTOM	PROBABLE CAUSE	SOLUTIONS
Algae	High pH	Shock with "POTASSIUM PEROXY MONOSULFATE"; adjust pH.
	Low free chlorine/bromine	Shock with "POTASSIUM PEROXY MONOSULFATE"; maintain sanitizer at recommended level
Eye Irritation	Low pH	Raise pH with "PH-UP".
	Insufficient free available chlorine/bromine	Shock with "POTASSIUM PEROXY MONOSULFATE".
Skin Irritation/Rash	Unsanitary/polluted water	Maintain recommended sanitizer residual at all times; super-chlorinate.
	Chlorine/bromine level too high (above 5ppm FAC)	Allow chlorine/bromine level to drop below 5 ppm before using spa.
Stains	pH or total alkalinity too low	Adjust pH and total alkalinity; use sequestering agent; drain and clean with appropriate product.
	High iron or copper in water source	Use sequestering agent for metals; adjust water
Scale	Too much calcium dissolved in water-pH	Adjust total alkalinity and pH levels by adding the appropriate sodium bisulfate product; with concentrated scale deposits, drain the spa, clean the liner as outlined in Liner Clean Up), refill the spa and balance the water.

TROUBLESHOOTING

I. RESETTING YOUR SPA

The first step to take to troubleshoot your spa is to reboot its electronic system. Like your PC at home, your spa electronics could get corrupted by electrical surges or other interference resulting in improper operations. **Before you call for service**, please reset or reboot your spa to see if the malfunction disappears. To properly reset your spa, unplug the **GFCI** and plug it back after 5 full minutes. Then press and hold down the **"UP"** arrow button for 5 seconds. The topside display will show **12:00PM** as soon as you release the **"UP"** button, the temperature will be reset to 102°F, indicating a successful system reset.

II. PUMP WILL NOT OPERATE AND TOP SIDE L.E.D. DISPLAY IS OFF

Cause:

There is no power to the spa.

Solution:

Check **GFCI** as outlined in **"Testing GFCI"** page 8.

1. If the **GFCI** tests properly, call the Service Center for assistance and mention code **"GFCI-1"**.
2. If the **GFCI** is inoperative, unplug the **GFCI** and test the electrical outlet using a 110v appliance such as a lamp or hair dryer.
 - a. If the appliance does not operate, your main panel circuit breaker has tripped. Reset it.

Note: If your breaker trips frequently, make sure your spa is not connected to an extension cord or that the electrical circuit your outlet is on does not have a major appliance connected to it. Poor household wiring and/or bad connection can cause low voltage and trip your circuit breaker. Make sure you have at least 110V at the outlet when the spa operate with the heater on. You might have to move your spa to connect it to a different outlet or ask a licensed electrician to run a dedicated circuit for it.

We suggest you spray the equipment system once every 2 months with WD-40, a silicone spray that is very helpful in protecting the equipment and electrical box from rust and moisture intrusion.

- b. If the appliance operates, the **GFCI** is defective. **DO NOT USE YOUR SPA.** Call the Service Center for assistance and mention the code **"GFCI-2"**.

III. PUMP WILL NOT OPERATE AND TOP SIDE L.E.D. DISPLAY IS ON

Cause:

Your system software could have been corrupted by electrical noise, spike or interference.

Solution:

Unplug the **GFCI** and plug it back in after 3-5 full minutes. Then press and hold down the **"UP"** arrow button for 5 seconds to reboot the system. The topside display will show 12:00PM as soon as you release the **"UP"** button. The temperature will be reset to 102F.

If the pump operates properly, set your desired water temperature and current time as outline in "Setting Time and Temperature" on page 8-9. If the pump does not operate and the topside is operative (pressing **"PROG"** button will switch time and temperature back and forth), the pump could have overheated and shut down. Wait a couple of hours for it to cool down. If the pump does not become operative within 4 hours, call the Service Center for assistance and mention the code **"PUMP-1"**.

IV. GFCI TRIPS WHEN TRYING TO OPERATE THE SPA DO NOT USE THE SPA.

Call Service Center for assistance and mention code **"GFCI-0"**

V. SPA WILL NOT HEAT TO DESIRED TEMPERATURE

NOTE that the pump needs to be operating on **LOW SPEED** for the heater to come on. If the pump does not operate, refer to items I and II.

1. Pump operates on low speed and there are no diagnostic messages shown on the display.

Cause:

Temperature is set too low

Solution:

Set the temperature higher. The spa water temperature will rise about 2 degree F. per hour depending on the season and if it is indoor or outdoor. Allow enough time for the spa to reach the desired temperature. Maximum allowed temperature is 104F.

Cause:

Spa cover is improperly positioned.

Solution:

Your spa needs to be covered properly if it is to heat properly, especially outdoors in cold climate.

Cause:

Filter cartridge could be dirty and restricting the water flow intermittently. The diagnostic message "**FLO**" will appear when this happens but you might not see it because it is intermittent.

Solution:

Remove the filter cartridge and clean as outlined in "**Filter Cartridge Removal and Clean Up**" page 13. If this does not solve the situation, call Service Center for assistance and mention the code "**LOW HEAT-1**"

2. Pump operates on low speed and there is a "**FLO**" diagnostic message: "**FLO**" indicates a low water flow or pressure condition resulting from an obstruction in the plumbing. Note that the heater is disabled for safety during that condition.

Cause:

Obstruction in the plumbing.

Solution:

- a. Remove the filter cartridge and clean it. See instruction on page 11 If the condition persists, there could be an

obstruction in the impeller of the pump. This condition could happen if the spa is operated without a filter cartridge. It is important to follow the "**Filter Cartridge Removal and Cleaning**" instruction of turning the spa off when removing the filter. Objects up to 1-1/2" in size could be sucked through and obstruct the line or pump impeller.

- b. Unplug the therapy module, lift it from the spa and inspect the plumbing by opening the unions for blocking materials such as hair, leaves, string, plastic bags, etc.

- c. If no blocking objects were found and the **FLO** message still shows, there could be a defective or out-of-calibration pressure switch. Call Service Center for assistance and mention the code "**FLO-1**"

3. Pump low or high speeds do not operate and there is a "**FLO**" message. Call Service center for assistance and mention the code "**FLO-2**".

4. Pump operates on low speed and there is a "**LS=0, LS=S, SS=0 or SS=S**" diagnostic message. This indicates a non-functional water or High Limit temperature sensor. Call the Service Center for assistance and mention the code indicated.

VI. NO WATER FLOW AT JETS AND THE PUMP IS OPERATING.

Cause:

Loss of prime in the module

Solution:

Prime module by following Priming Instruction on page 10. (Check the pump unions to make sure they are not loose.) If this does not solve the problem, call Service Center for assistance and mention code "**NO FLOW-1**"

VII. LACK OF PRESSURE AT ONE OR SEVERAL OF THE JETS

Cause:

Jet(s) could be closed.

Solution:

Open jet(s). The flow of the jets is controlled by the jet finger ring. Adjust the ring to direct the water to the desired jets. See instructions on page 12.

Cause:

Obstruction in plumbing.

Solution:

Remove the jet face(s), clean and re-install. See section on HYDROTHERAPY JETS. If any of the above does not solve the problem, (page 12) call Service Center and mention code "**LOW FLOW-1**"

IX. THERAPY MODULE LEAKS

Cause:

Loose union(s) at the pump.

Solution:

Unplug the module. Remove door to the unions. Hand tighten. Do not use pliers. If the leak is anywhere else, call Service Center for assistance.

X. WATER LEAK THROUGH THE LINER

Cause:

Puncture of the liner.

Solution:

Patch the hole using a vinyl patch kit. A vinyl patch kit can be obtain at your retailer or by calling the Service Center. In the unlikely event that the leak is at the seam, call the Service Center to order your replacement liner.

XI. WATER NOT CLEAR

Cause:

Dirty filter cartridge.

Solution:

Clean or replace the cartridge.

Cause:

Improper water chemistry.

Solution:

See "Balancing your spa water" and "Water Maintenance" sections on page 13-15.

Cause:

High content of solid in water.

Solution:

Use clarifier or drain and refill the spa.

SERVICE CENTER

Your Voyager Therapy Module has been designed to minimize service requirements. There are no user serviceable parts in the module.

9am - 5pm Mon.-Fri. EST

Toll Free: (877) 240-9457

or (305) 908-8187

Fax: (305) 685-9794

e-mail:

voyager@dmindustries.com

Attn: Voyager Service Center

Do not try to service the module or the GFCL. If you have an operation problem, go carefully through the troubleshooting steps outlined in the troubleshooting section of this manual. If you cannot correct the problem, contact DM Industries Ltd.'s Service Center for assistance or for the nearest Service Center to you.

DIAGNOSTIC MESSAGES

- FLO** **Flow Protection** - If the flow of water through the heater is insufficient, the spa controller will automatically turn off the heater to prevent overheating. The display will show "**FLO**", indicating a flow restriction caused by a clogged filter or pump impeller, a malfunction of in the pressure switch or a defective pump motor. Refer to the Trouble Shooting Chart. If you cannot pinpoint the cause, Call the Service Center for assistance.
- HILI** **Overheat Protection** - If a malfunction occurs and the spa water temperature reaches 112F, the pump and heater will turn off. **DO NOT ENTER THE WATER.** Remove the cover and allow the water temperature to cool down to 104 F. The pump and heater will start normal operation when the water temperature reaches 104F. If his happens a second time in a row, **UNPLUG THE SPA AND CALL THE SERVICE CENTER FOR ASSISTANCE.**
- If there is an overheat condition in the spa heater (118F), the display will show the message "HILI". **DO NOT ENTER THE WATER.** Remove the cover and allow the water to cool down to 104F. Then reset the system by holding down the "DOWN" button for 5 seconds. If the "HILI" message returns, **UNPLUG THE SPA AND CALL THE SERVICE CENTER FOR ASSISTANCE.**
- ICE** **Freeze Protection** - If the temperature in the spa plumbing falls below 50 degrees Fahrenheit (10 degrees Celsius), the topside will display the message "ICE" to indicate potential freeze conditions. The water pump will turn on low speed and run for one minute. After one minute, if the water is still at 50 F, the heater will turn on and raise the temperature 10 degrees. The topside control will display the message "ICE" to indicate potential freeze conditions.
- LS=0** **Open Sensor** - The water temperature sensor is non-functional. Call the Service Center for assistance and mention the displayed code.
- LS=S**
- SS=0,** **Open Sensor** - The High Limit temperature sensor is non-functional.
- SS=S** Call the Service Center for assistance and mention the displayed code.

SPECIFICATIONS

Capacity

Seating	4-6 Adults
Water (average fill)	400 Gallons

Spa

Outside Dimensions	72 inches
Inside Dimensions	66 inches
Overall Height	34 inches
Water Depth (average fill)	28 inches

Therapy Module

Number of Jets	8
Directional	2
Turbo Whirlpool Pump	1 Single phase, 110V/60HZ 2 speed
Heater	1.5kw 110V
Digital Control	LV15 – 12V
Filter	25 sq. ft. Remy Polyester
Module Rating	110V 15A

Weights

Spa complete dry	280 lbs
1 each, Box A: Therapy Unit	76 lbs
3 each, Boxes B: Wall (2 walls/box)	40 lbs each box
3 each, Boxes C: Seat (2 seats/box)	21 lbs each box
1 Box accessory parts:	
Liner-Bands-Warranty instructions	36 lbs.
Spa with water at 28" * Approx.	3600 lbs **
Spa with water at 34" *** Approx.	4300 lbs. **

Dead Weight Floor Loading

With water at 28"	150 lbs per square foot
With water at 34"	180 lbs per square foot

* Minimal utilization height - 1" above highest Jet.

** Weight of users not included

*** Maximum water height

All sizes are approximate. Specifications subject to change without notice.

OPTIONAL ACCESSORIES

To purchase these optional accessories, contact your local dealer or call **DM Industries, Ltd's Service Center** at **305.908.8187** or **Toll Free 877.240.9457**. Fax us at **305.685.9794** or E-mail us at **voyager@dmindustries.com**.



SHELF & TOWEL RACK

Made of wood for strength.
Easily attaches to spa wall.

STEPS

Two slip resistant treads for easy entry. Made of the same material as your Voyager Spa.

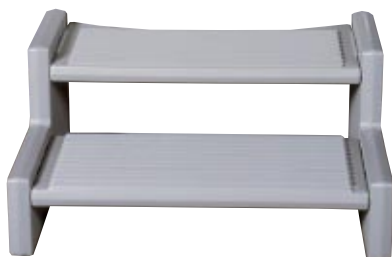

COLD WEATHER INSULATING SYSTEM

Four piece "blanket" sections easily installs with Velcro, completely enclosing the spa. Outer jacket is an attractive grey marine naugahyde that matches the Voyager. This is sewn to Reflective®, the same five-layer space age material used in survival blankets and sunshades. Controls 97% of radiant heat loss and also serves as an additional thermal barrier.



REPOSITIONAL HEADREST

For extra head and neck support.

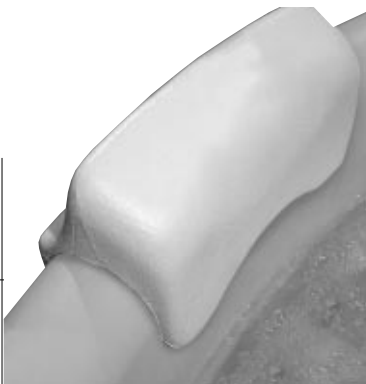

VOYAGER PACK REMOVAL INSTRUCTIONS:

If at anytime during the life of your Voyager unit, it is found necessary to repair the control system, by following the steps below, the system can easily be removed and brought to a service center.

1. Disconnect power to spa by unplugging the unit.

2. Lift the therapy unit from out of the spa.



3. Set the therapy unit down on a level surface.

4. Open the small access door to view the control box.





FIG. A



FIG. B

5. Three different assemblies can be removed for service.
 - a. The control system including the control panel. (FIG. A)
 - b. The pump assembly. (FIG B)
 - c. The entire equipment assembly (Control System and Pump Assembly)

6. REMOVAL OF THE CONTROL SYSTEM

- a. Lift the topside control pad from the cowl by prying it up and feed through the opening under it into the therapy module.
- b. Disconnect the pump power supply cord from the metal control box.
- c. Reach through the access door and loosen the 2 heater nuts (1 & 2 FIG. A)



7. Reach through the side of the therapy unit and lift and remove the control system with the control panel and power cord.

8. Package the equipment so that no damage may be done to the control pad wiring or the sensors attached to the heater assembly. Leave the GFCI power cord attached to the equipment and carefully coil it so that no damage may occur during shipping.

9. When the equipment is returned, replace it by reversing the order of removal.

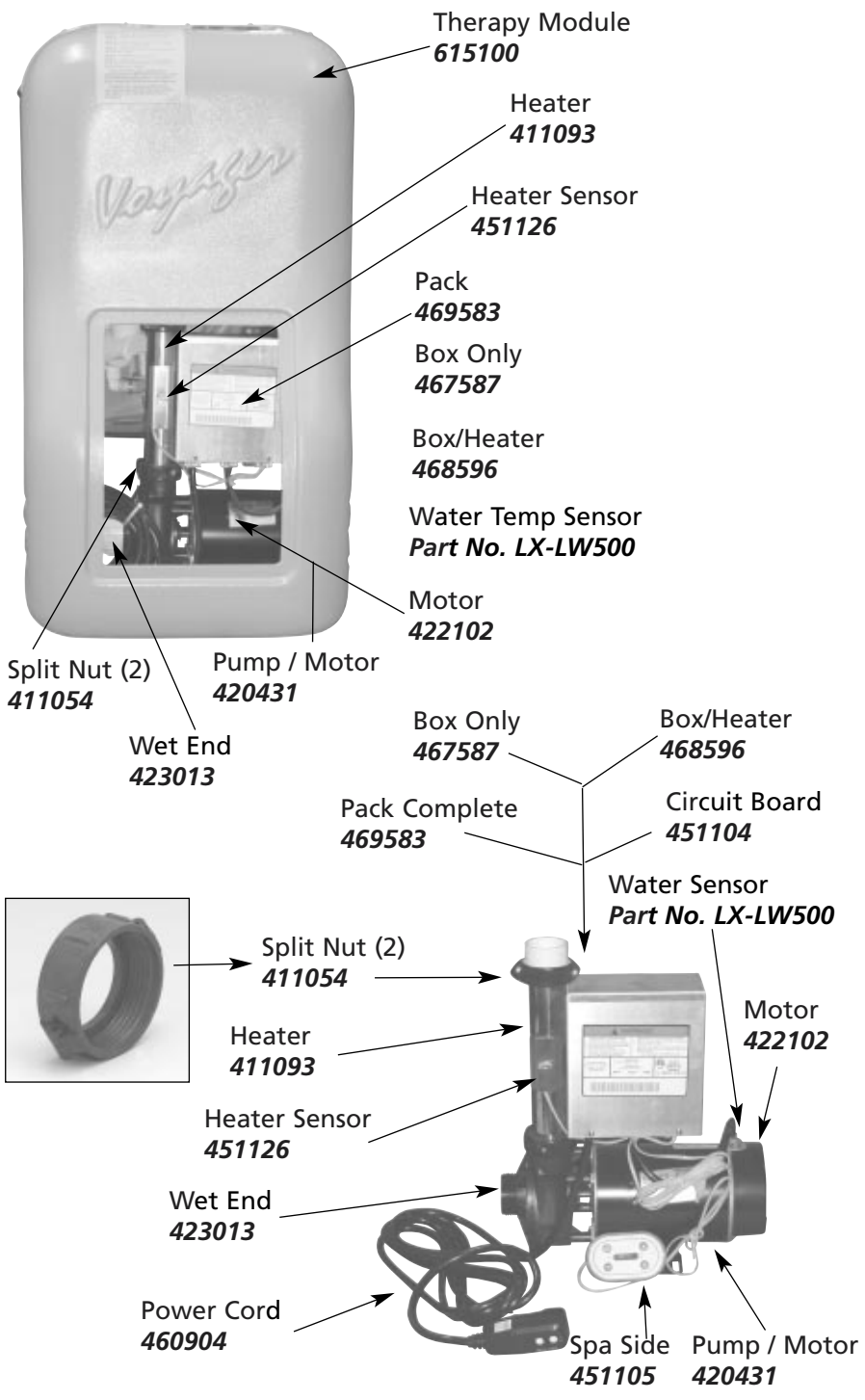

LIMITED REPLACEMENT WARRANTY

DM Industries Ltd warrants the VOYAGER SPA to be free of defects in material and workmanship from the periods indicated below from the date of purchase.

Component	Warranted for
Wall Sections	3 Years
Seats.	3 Years
Vinyl Liner	3 Years
Therapy Module	1 Year
Cover	1 Year

Extent of Warranty:

This warranty extends only to the original purchaser of the Voyager and terminates upon transfer of ownership. The warranty does not extend to commercial, institutional or rental use or installation. The warranty applies only to Voyagers installed within the United States. This warranty is an "Over-the-Counter" replacement warranty. All freight charges are the responsibility of the purchaser. All warranted repairs will be performed at no charge during the warranty periods. Components requiring servicing under this warranty will be repaired or replaced at DM Industries Ltd's sole discretion. Repair work done by DM Industries Ltd or its Authorized Service Centers is guaranteed for 90 days or for the remainder of the warranty period, which ever is longer.

Warranty Process:

All warranty inquiries should be addressed to DM Industries Ltd 's Service Center at toll free number (M-F, 8:30am to 5pm EST) or by Fax at (305) 685-9794 or by E-mail at dmindustries.com Attn: Voyager Service Center or in writing to 2320 NW 147 Street, Miami, FL 33054. An RGA (Return Good Authorization) number will be issued and components requiring services shall be returned to DM Industries Ltd. or its Authorized Service Center, freight prepaid.

Exclusion:

This warranty is void if DM Industries Ltd determines that the spa has been subjected to any alterations or repairs by anyone other than an authorized service center, or that the spa has been subjected to misuses, negligence, improper installation or operations other than in accordance with the instructions in the owner's manual, including but not limited to damage to components caused by improper pH balance or other improper water chemistry maintenance, or by failure to maintain and clean the filtration systems; damage to the components or the vinyl liner caused by operating the spa without water or at the improper water level, filling or operating the spa with water at temperature below 40 deg F or above 104° F, using an extension cord, or allowing undissolved or concentrated chemicals to lie on the vinyl surface, or leaving the spa empty in direct sunlight

Disclaimer.

Except as expressly provided, there shall be no other warranty or obligation, expressed or implied, oral or statutory. No retailer or other person has the authority to make any warranties or representations covering DM Industries Ltd or its products. DM Industries Ltd and its representatives shall not be liable for any injury, loss, cost or other damage, including but not limited to, loss of use, inconvenience, cost of removal of a permanent installation, or any other incidental or consequential costs, expenses, or damages. Under no circumstances shall DM Industries Ltd or any of its representatives be held liable for injury to any persons or damage to property, however arising. Some states do not allow exclusions or limitations of incidental or consequential damages, so the aforementioned limitations or exclusions may not apply to you. This warranty gives us specific legal rights, and you may also have other rights that vary from state to state. All specifications are subject to change without notice.

DM Industries Ltd.'s Service Center

Toll Free at: (877) 240-9457 or (305) 908-8187

Fax: (305) 685-9794

or e-mail us at: voyager@dmindustries.com

Attn: Voyager Service Center

Maintenance Log

Use this page to keep a record of when you perform any maintenance on your spa.



DM Industries Ltd.'s Service Center

**Toll Free at
(877) 240-9457
or
(305) 908-8187**

**Fax:
(305) 685-9794**

**or e-mail us at
voyager@dmindustries.com**

**Attn:
Voyager Service Center**