

KOHLER

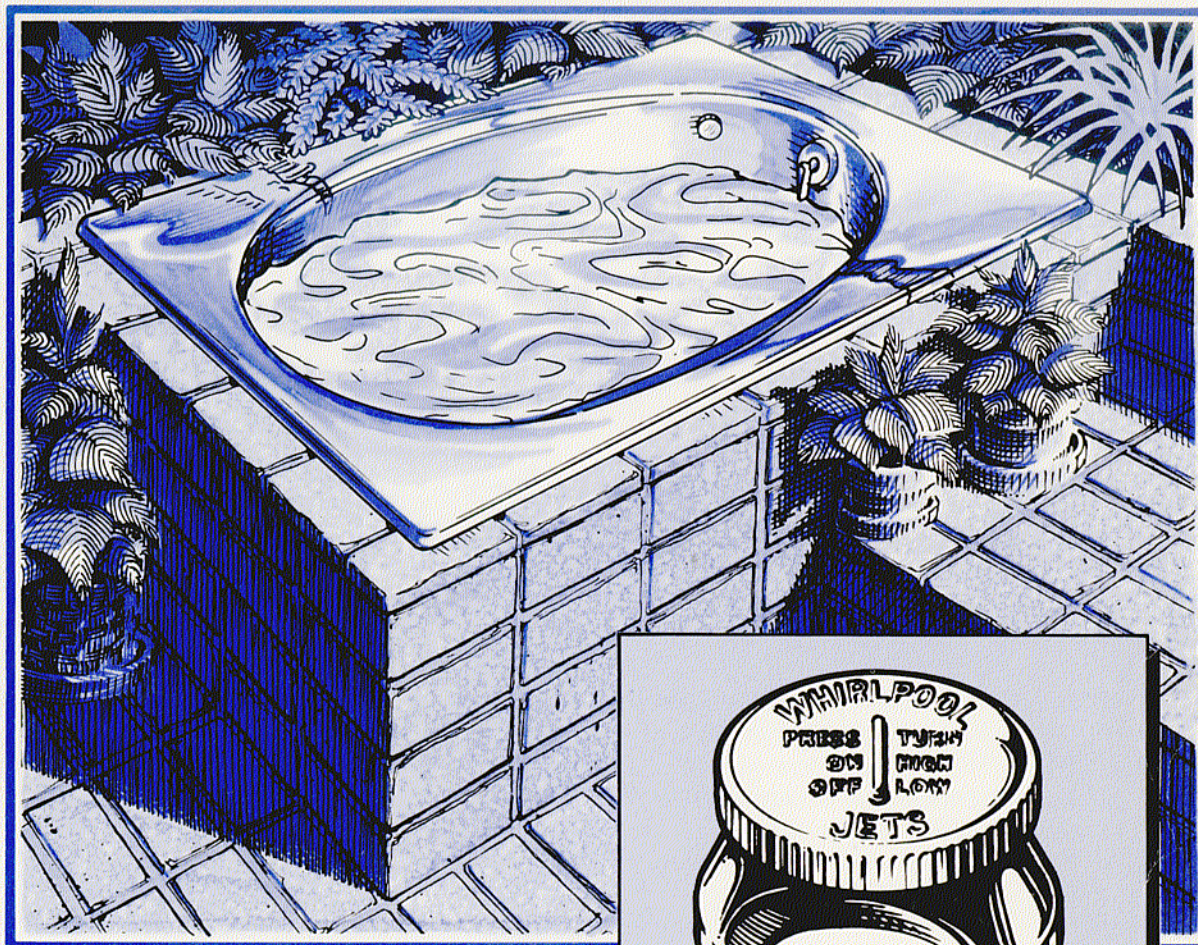

KOHLER WHIRLPOOL SERVICE MANUAL

With Air Actuator/Aspirator Control For "SA" Series Whirlpool Baths



This manual covers service and maintenance procedures for the following Kohler Whirlpool models:

- SUPERBATH™ WHIRLPOOL K-1422-SA
- Infinity ∞ Bath™ WHIRLPOOL K-1482-SA, K-1484-SA
- CARIBBEAN™ BATH WHIRLPOOL K-802-SA
- STEEPING BATH™ WHIRLPOOL K-792-SA
- GUARDIAN™ BATH WHIRLPOOL K-783-SA, K-784-SA
- BARBADOS™ BATH WHIRLPOOL K-1409-SA, K-1410-SA
- PRISTINE™ BATH WHIRLPOOL K-772-SA
- "Greek"™ BATH WHIRLPOOL K-1492-SA
- Hourglass ⌘ Bath™ WHIRLPOOL K-1512-SA

TABLE OF CONTENTS

SECTION 1 GENERAL INFORMATION	
INTRODUCTION	1
WARNINGS AND PRECAUTIONS	1
SERIAL NUMBER AND SERIES CODE	
LOCATION	1
SERVICE AND MAINTENANCE	2
SECTION 2 GENERAL SYSTEM DESCRIPTION	
THEORY OF OPERATION	3
COMPONENT IDENTIFICATION LIST ...	3
WATER AND AIR FLOW	4
TROUBLESHOOTING FLOW CHART ...	5
WIRING DIAGRAM	7
SECTION 3 AIR ACTUATOR/ASPIRATOR ASSEMBLY	
THEORY OF OPERATION	8
SERVICING THE AIR ACTUATOR/ ASPIRATOR ASSEMBLY	8
COMPONENT IDENTIFICATION LIST ...	9
SECTION 4 POWER PANEL ASSEMBLY	
THEORY OF OPERATION	10
SERVICING THE POWER PANEL ASSEMBLY	10
COMPONENT IDENTIFICATION LIST ...	11
SECTION 5 MOTOR AND PUMP	
THEORY OF OPERATION	12
SERVICING THE MOTOR AND PUMP ...	12
KOHLER MODELS 60660-M, AND 60661-M MOTOR AND PUMP	12
COMPONENT IDENTIFICATION LIST ...	13
	KOHLER MODELS 60660-H, AND 60661-H MOTOR AND PUMP
	14
	COMPONENT IDENTIFICATION LIST ...
	15
	KOHLER MODELS 60662-M, AND 60663-M MOTOR AND PUMP
	16
	COMPONENT IDENTIFICATION LIST ...
	16
	KOHLER MODEL 60388-M MOTOR AND PUMP
	17
	COMPONENT IDENTIFICATION LIST ...
	18
	SECTION 6 TRIM KITS
	SERVICING THE TRIM KITS
	19
	Adjustable Jets (Brass)
	19
	Suction Inlet (Brass)
	19
	Adjustable Jets (Plastic)
	19
	Suction Inlet (Plastic)
	19
	SERVICING THE ASPIRATOR ASSEMBLY
	19
	COMPONENT IDENTIFICATION LIST (BRASS)
	20
	COMPONENT IDENTIFICATION LIST (PLASTIC)
	21
	SECTION 7 PLASTIC JET AND SUCTION SERVICE
	SERVICING PLASTIC JET ASSEMBLY AND SUCTION ASSEMBLY
	22
	COMPONENT IDENTIFICATION LIST ...
	22
	COMPONENT IDENTIFICATION LIST ...
	23
	COMPONENT IDENTIFICATION LIST ...
	24
	SERVICE NOTE
	24

SECTION 1 — GENERAL INFORMATION

INTRODUCTION

The purpose of this manual is twofold: to provide familiarization with Kohler Whirlpool Bath operation and to provide detailed maintenance and functional check-out instructions.

This manual contains a general system description, functional checkout procedures, and an identification of all major components. Theory of operation and repair information for the individual components are included in their respective sections.

WARNINGS AND PRECAUTIONS

1. Kohler Company does not assume responsibility for warranty repairs performed by anyone other than an Authorized Service Representative (ASR).
2. When servicing the power panel, motor, and pump or any portion of the system where high voltages may be encountered, ensure power to the Whirlpool Bath is OFF.
3. All electrical work shall be performed by a qualified electrician or ASR.
4. Pump motor may operate at high temperatures; avoid coming in contact with motor shell while pump motor is operating or shortly after shut-down.
5. After servicing the Whirlpool Bath, always re-install all safety devices as originally found prior to repair or service.
6. Local electrical codes may require use of a Ground Fault Circuit Interrupter (GFCI) on circuits supplying power to the Whirlpool Bath. Kohler Company requires the use of a GFCI on all installations.
7. All finish materials — enamels, acrylic, plating, etc. — can easily be damaged. Do NOT stand or place tools in Whirlpool Bath. Kohler Company will not be held responsible for damage to finish caused during repair.
8. Modifications, additions, or deletions shall not be made to Kohler Whirlpool Baths.
9. Instructions, drawings, and schematics contained in this manual represent information available at time of printing. Although every attempt has been made to keep them as up-to-date as possible, Kohler Company reserves the right to implement product changes without prior notice.

10. Kohler Company will not assume responsibility for product performance or safety where replacement components or parts other than Genuine Kohler Replacement Parts or authorized alternates are used.
11. Kohler Company recommends all gaskets, seals, and O-rings be replaced if removed during service or inspection procedures.

SERIAL NUMBER AND SERIES CODE LOCATION

The serial number is an 8-character code assigned to each Whirlpool Bath to provide a uniform method of permanently identifying each unit. The series code is a two (2) character alpha code identifying a specific feature of the Whirlpool model and is located on the same label as the serial number. Both codes are located on a label attached to the Whirlpool Bath pipe harness return line directly above the air switch power panel. It is visible after installation with the access panel removed (refer to Figure 1-1).

All warranty reports and invoices must include the serial number and series code.

The serial number indicates the following:

- Manufacturing facility.
- The decade in which it was manufactured.
- The year of manufacture.
- The month of manufacture.
- In-plant identification.

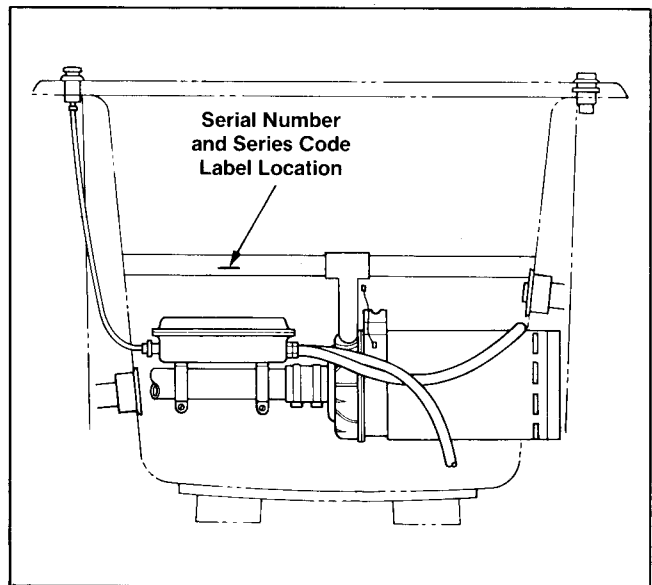

Figure 1-1. Serial Number and Series Code Location

The series code indicates the following:

- SA — Whirlpool Timing System with air actuator/ aspirator and air switch controls.
- Refer to Plate Number — SA in the SP3A Service Parts Catalog.

This service manual applies to Whirlpool Baths with the series code "SA" only.

For Whirlpool Baths with series codes other than SA or no series code, refer to the following:

- Kohler Whirlpool Service Manual With Electronic Timer. Publication Number 105582.
- Kohler Whirlpool Service Manual With Air Actuated Controls. Publication Number 105583.

Manufacturing Facility Code — The first character (alpha) in the string of numbers as listed below.

Manufacturing Facility	Code Pre Jan. 1, 1983	Code Post Jan. 1, 1983
Brownwood	C	T
Richmond	R	R
Spartanburg	B	S
Toledo	A	A
Wisconsin	D	W

Decade When Manufactured — The second character (numeric) in the string of numbers.

Examples: 7 for the 70's, 8 for the 80's, etc.

Year of Manufacture — The third character (numeric) in the string of numbers.

Examples: 8 for 78, 1 for 81, 2 for 82, etc.

Month of Manufacture — The fourth character (alpha) in the string of numbers as listed below.

Month	Code	Month	Code
January	A	July	G
February	B	August	H
March	C	September	I
April	D	October	J
May	E	November	K
June	F	December	L

In-Plant Identification — The fifth through eighth characters (numeric) in the string of numbers are used for in-plant identification.

Examples:

- Manufactured pre January 1, 1983. D78A0006
 - D. Wisconsin manufacturing facility.
 - 7. Manufactured in the 70's.
 - 8. Manufactured in 1978.
 - A. Manufactured in January.
- Manufactured post January 1, 1983. W83B0006
 - W. Wisconsin manufacturing facility.
 - 8. Manufactured in the 80's.
 - 3. Manufactured in 1983.
 - B. Manufactured in February.

SERVICE AND MAINTENANCE

Kohler Whirlpool Baths require a minimum of maintenance for trouble-free operation. Removal and replacement procedures, as well as repair techniques for the various components of the Whirlpool Bath, are provided in the following sections of this manual.

Only commonly used tools are required to service Kohler Whirlpool Baths, however, a multimeter is required to test the electrical components of the system.

Service should be performed by an Authorized Service Representative (ASR).

WARNING: When servicing the power panel assembly, motor, and pump or any other portion of the system where high voltages may be present, ensure the power to the Whirlpool Bath is OFF. If voltage measurements are required, use caution.

Service and maintenance procedures described in this manual apply to all models of the Whirlpool Bath furnished with air switch controls (series "SA"). Although component configuration may differ from model to model, operation and service are relatively the same.

SECTION 2— GENERAL SYSTEM DESCRIPTION

THEORY OF OPERATION

Each air actuated Kohler Whirlpool Bath typically consists of four basic components:

- Tub which acts as a reservoir for the water and provides a location for whirlpool action.
- Air control actuator/aspirator which turns the Whirlpool Bath ON and OFF through activation

of the air switch, relay, and timer assembly (refer to Figure 2-1).

- Power panel assembly which includes air switch, relay, and timer assembly to drive the motor and pump.
- Motor and pump which provide the power to move the water and create the whirlpool action.

COMPONENT IDENTIFICATION LIST

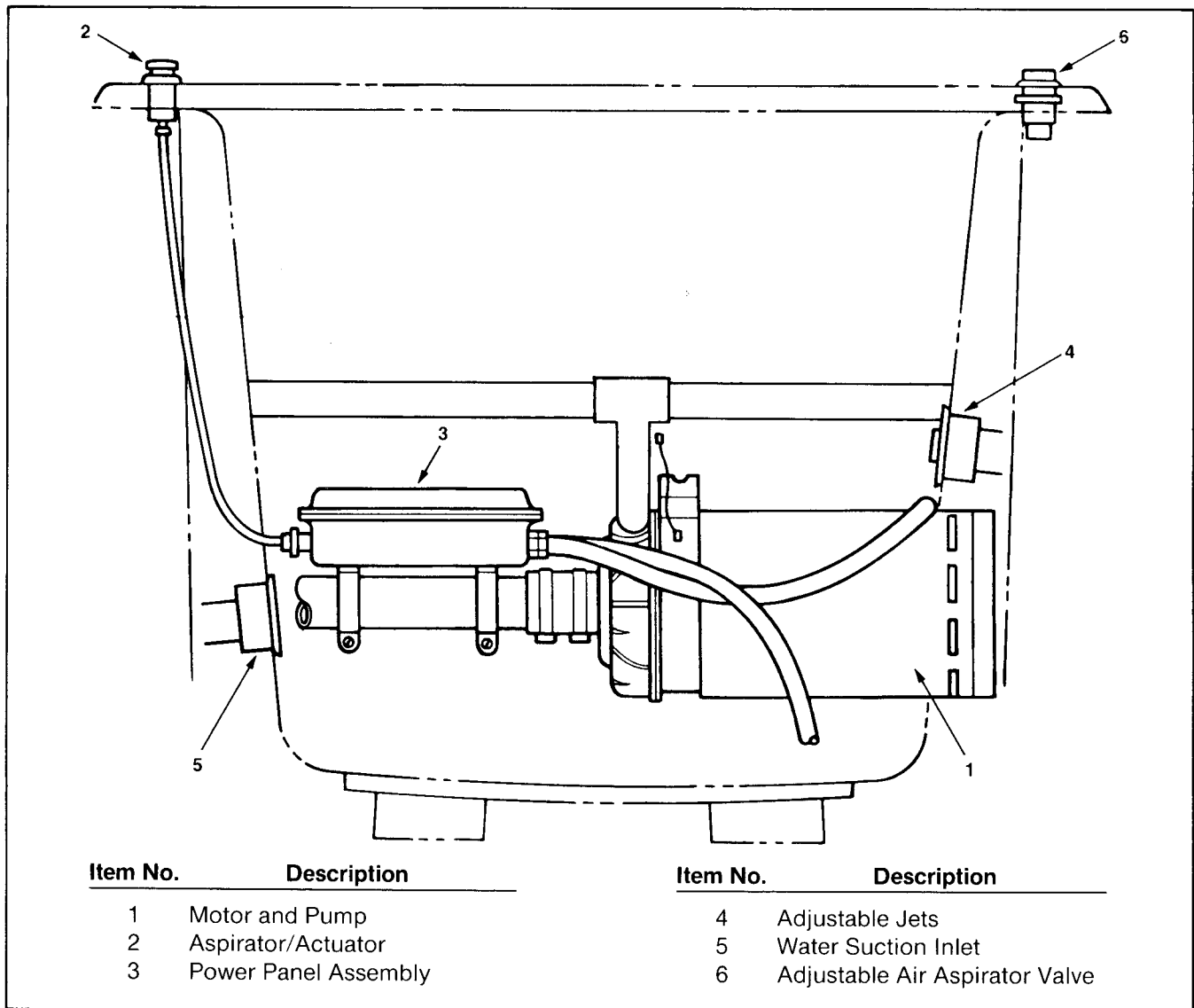

Figure 2-1. Whirlpool Components

WATER AND AIR FLOW

Basic water flow for the Kohler Whirlpool Bath is depicted in Figure 2-2. Once filled with water, the Whirlpool Bath becomes a self-contained system.

Water is drawn from the tub through the water suction inlet typically located near the bottom of the tub,

pulled into the pump, and forced back out to the tub through adjustable jets located in the tub walls.

Air is mixed with the water stream at the jets and adjusted using the air aspirator controls.

This cycle continues as long as the motor and pump are operating.

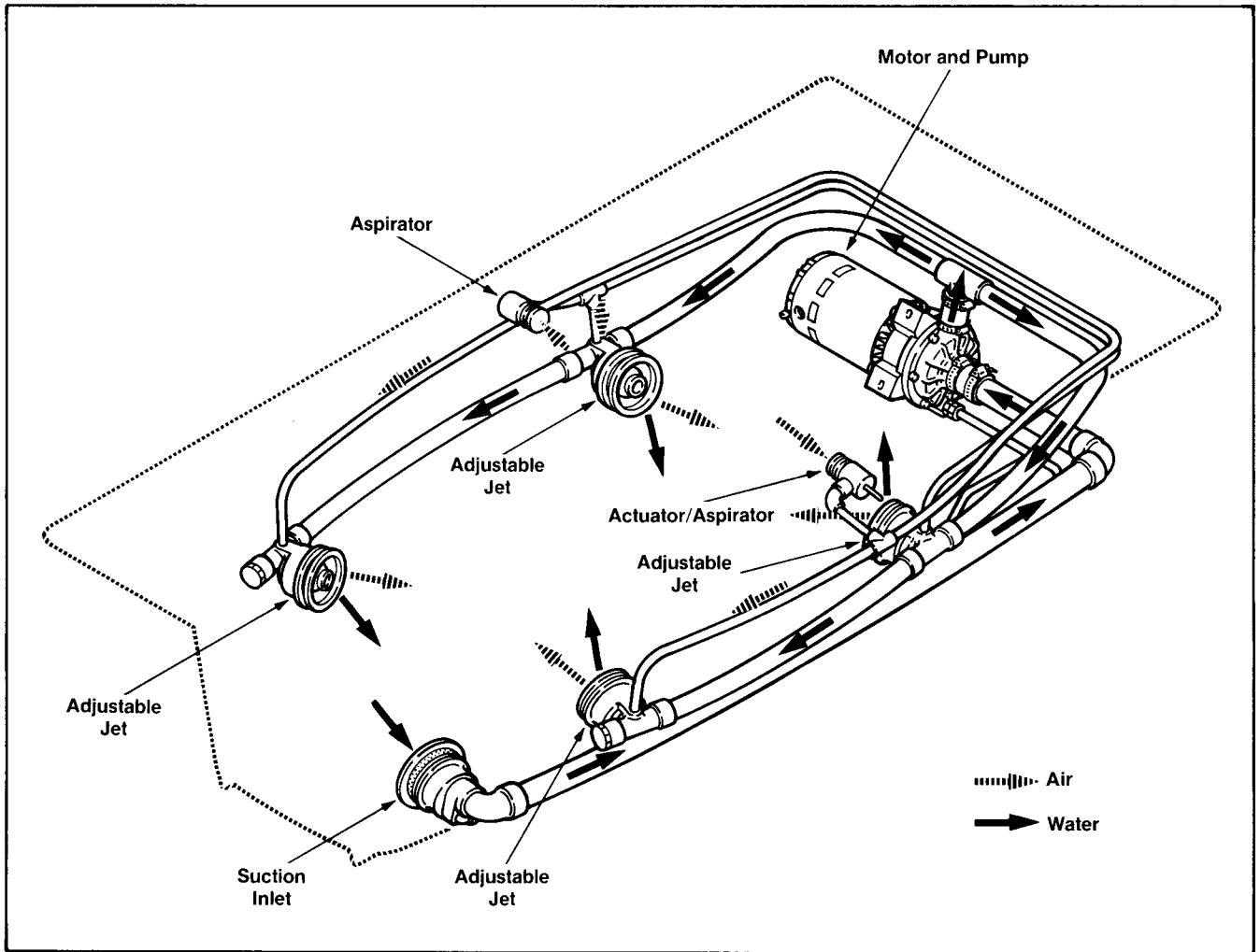
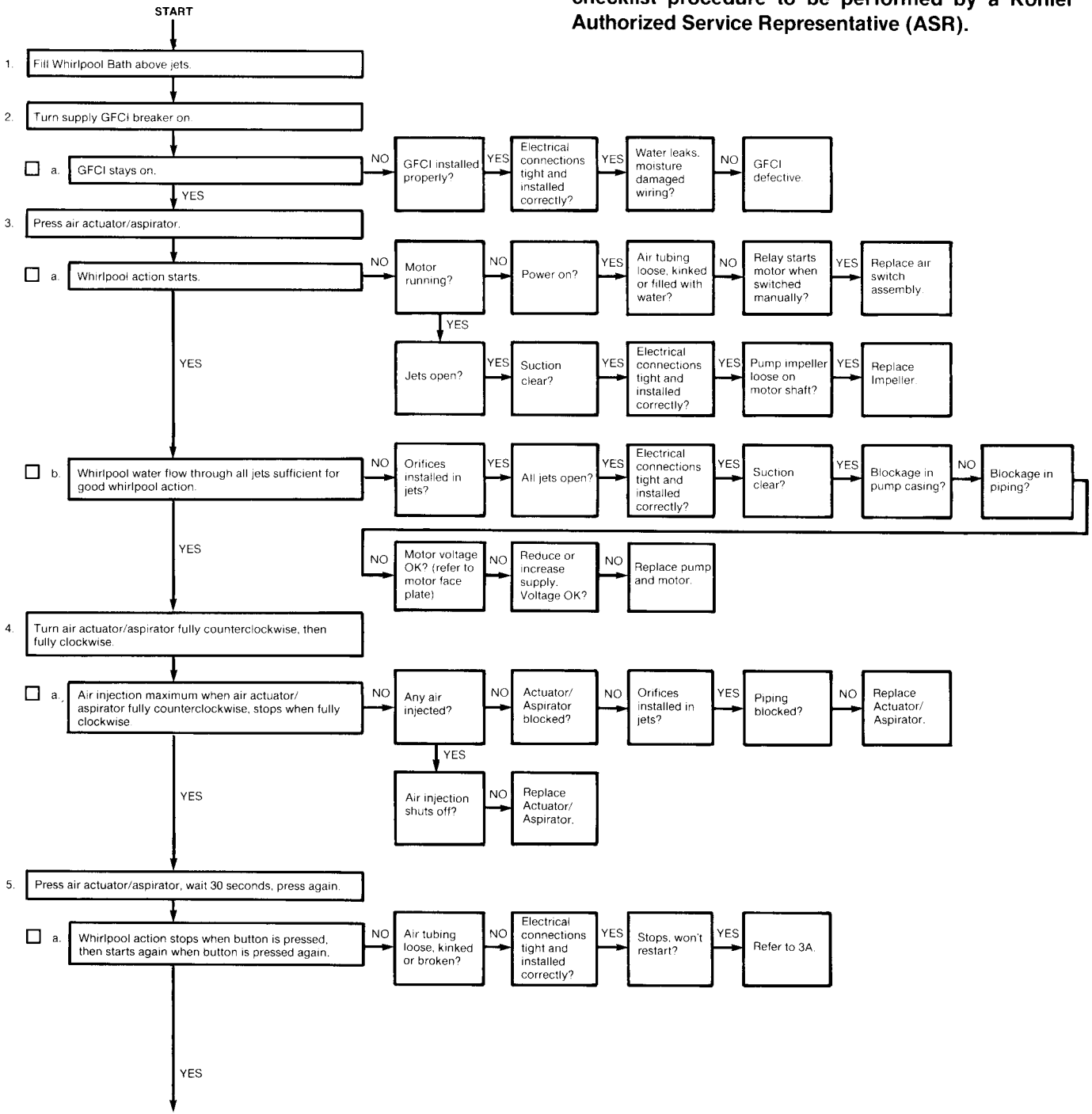

Figure 2-2. Water and Air Flow

TROUBLESHOOTING FLOW CHART

NOTE: This flow chart has been designed as a 7 step checklist procedure to be performed by a Kohler Authorized Service Representative (ASR).



CONTINUED ON NEXT PAGE

CONTINUED

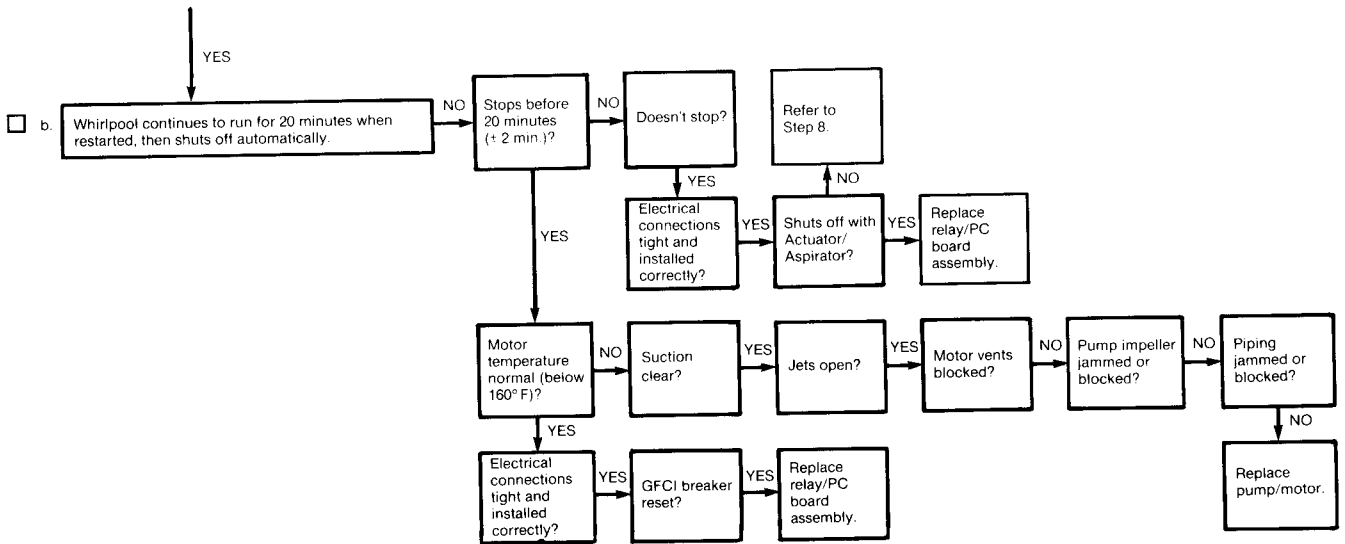

The Whirlpool Bath is now operating properly.

The following are troubleshooting steps dealing with inconsistent or erratic operation:

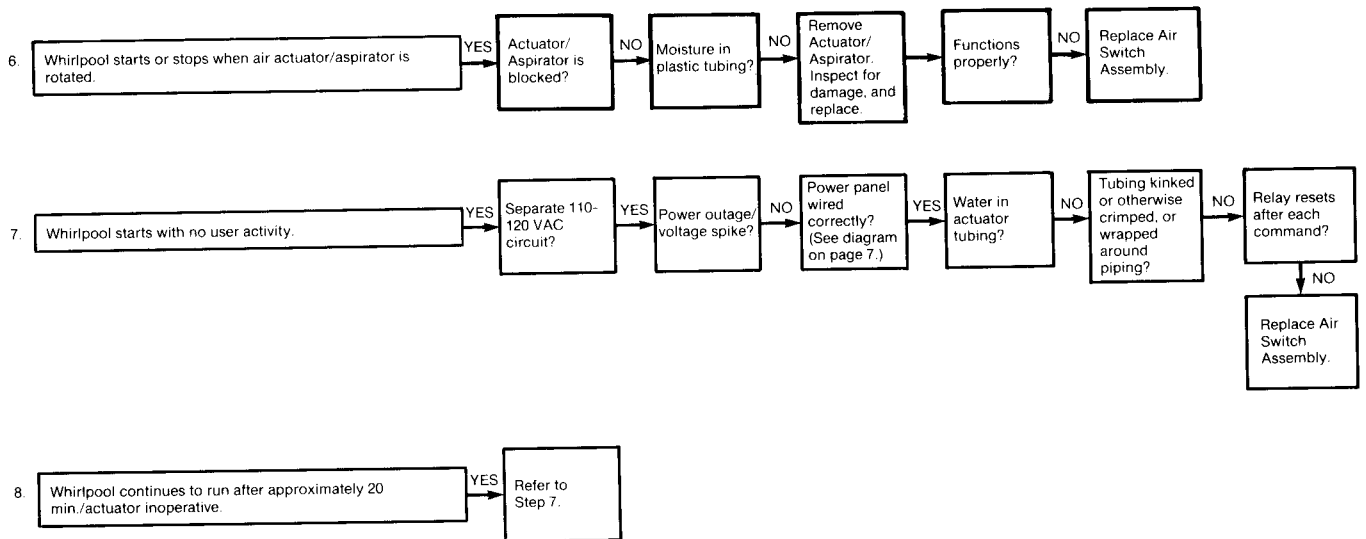

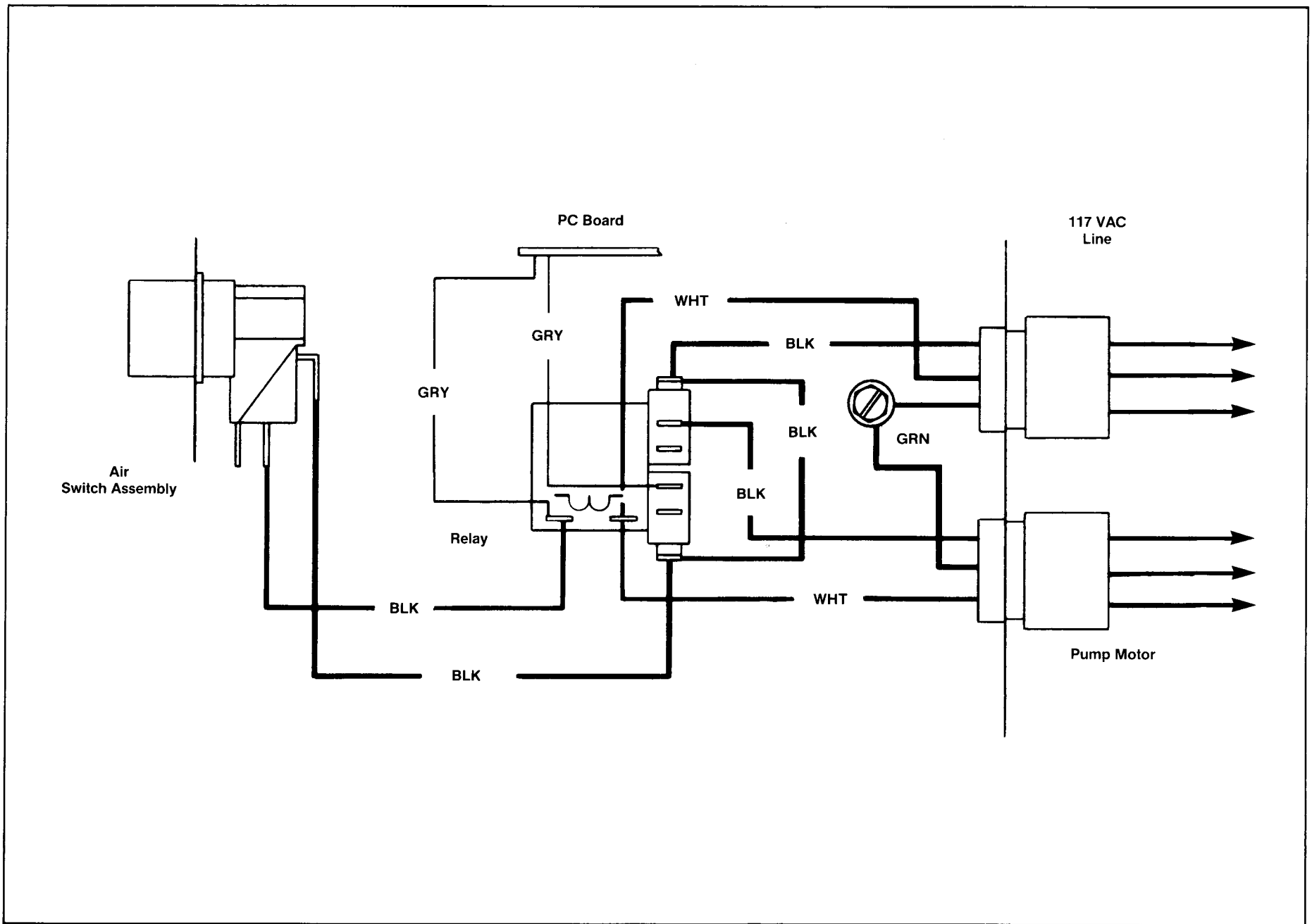

Figure 2-3. Wiring Diagram

SECTION 3— AIR ACTUATOR/ASPIRATOR ASSEMBLY

THEORY OF OPERATION

When the air control actuator is pressed an air bellows located in the housing is compressed. At this point the air bellows delivers a pulse of air to the power panel and the power panel starts the pump and motor.

SERVICING THE ACTUATOR/ASPIRATOR ASSEMBLY

Servicing the air actuator/aspirator assembly is limited to replacement of defective components (refer to Figure 3-1).

WARNING: Turn GFCI OFF before servicing.

The air control actuator assembly may be serviced using the following procedure:

1. Gently pry dual control aircap from air control actuator assembly.
2. Gently pry tapered trim cap from housing.

CAUTION: Tapered trim cap may be sealed with RTV sealant. Use care when removing tapered trim cap as not to damage finish.

3. While gently pulling outward on air control actuator assembly, depress both retainer tabs on sides of control and remove assembly from housing.
4. Remove air bellows from housing. Remove plastic tubing from air bellows.

CAUTION: Do not allow plastic tube to fall inside tub enclosure. You may not have access to recover the tube.

NOTE: The dual control aircap, tapered trim cap, air control actuator, air bellows, and gasket may be replaced at this point. Do NOT remove housing

from body unless it is seriously damaged. The housing cannot be repaired unless a special tool is obtained. The tool is available from Kohler Consumer Affairs.

5. Remove housing from body using a special tool and turning counterclockwise.
6. Remove gasket.
7. Replace parts as necessary.

To reassemble:

1. Install housing into body from inside of bath and tighten clockwise. **NOTE:** Use teflon tape on housing threads. The use of RTV silicone sealant should be avoided.
2. Attach plastic tubing to bellows. Install air bellows and gasket in housing.
3. Install air control actuator assembly in housing. The stationary lugs toward the bottom of the air control actuator assembly must align with the matched grooves molded into the housing. The retainer tabs must align with the slots at the top of the housing. Press and snap into place.
4. Apply small amount of RTV sealant under tapered trim cap. Press tapered trim cap onto housing.
5. Align drive lugs on air control actuator assembly with matching holes in underside of dual control aircap. Press dual control aircap onto air control actuator assembly.
6. Fill Whirlpool Bath. Turn GFCI ON and test for proper operation.

COMPONENT IDENTIFICATION LIST

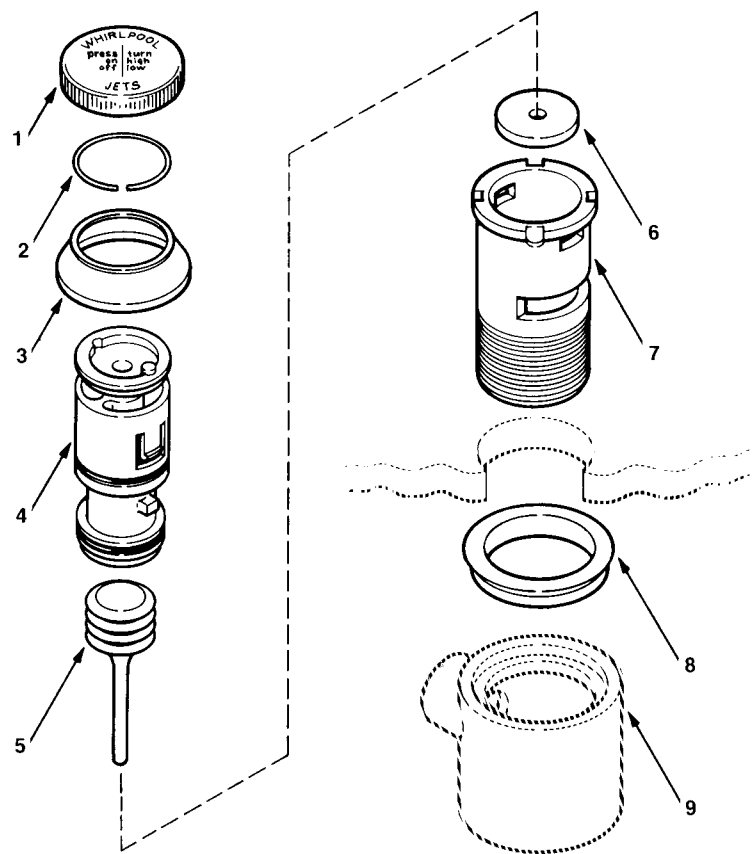

Item No.	Description	Quantity
1*	Dual Control Aircap	1
2*	Spring Ring (Part of Item 1)	1
3*	Tapered Trim Cap	1
4	Air Control Actuator Assembly	1

*Part of Trim Kit

Item No.	Description	Quantity
5	Air Bellows	1
6	Gasket	1
7	Housing	1
8	Gasket	1
9	Body	1

Figure 3-1. Actuator/Aspirator Assembly

SECTION 4— POWER PANEL ASSEMBLY

THEORY OF OPERATION

The power panel consists of the electrical box, cover, gasket, air switch assembly, PC board, and relay (refer to Figure 4-1).

When the whirlpool is off and the air actuator/aspirator control is pressed, the air pulse momentarily closes the air switch and relay in the power panel. The air switch and relay in turn activates the power supply to the pump motor and timer (PC board) circuitry.

After approximately 20 minutes of operation, the timer circuitry deactivates power to the pump motor, stopping the whirlpool action.

If the air actuator/aspirator control is pressed while the whirlpool pump is on, the air pulse again momentarily closes the air switch and relay in the power panel, interrupting power to the pump motor and stopping the whirlpool action. The timer (PC board) then automatically resets at approximately 20 minutes.

SERVICING THE POWER PANEL

Servicing the power panel is limited to replacement of defective components.

To service the power panel, proceed as follows:

CAUTION: Turn GFCI OFF before servicing the power panel.

1. Remove screws securing electrical box cover to electrical box. Remove electrical box cover. Remove and replace gasket if damaged.

2. Mark and disconnect leads to air switch assembly. Remove air switch from electrical box by depressing retainer tabs. Disconnect plastic tubing from air switch.
3. Loosen screws securing relay mounting bracket to electrical box. Remove relay and PC board bracket from electrical box.
4. Mark and disconnect leads from relay.
5. Replace components as necessary.
6. Connect leads to replacement relay.

CAUTION: Leads must be installed on terminals as outlined on Wiring Diagram (Figure 2-3). Failure to install leads on correct terminals will result in erratic operation of the Whirlpool Bath.

7. Install replacement relay and PC board mounting bracket in electrical box. Tighten screws securely.
8. Connect leads to air switch and install air switch in electrical box. Connect plastic tubing to air switch.
9. Install gasket on electrical box cover. Install cover and gasket on electrical box.
10. Install screws securing cover and gasket to electrical box. Tighten screws securely.
11. Turn GFCI ON and fill Whirlpool Bath. Test operation of power panel.

COMPONENT IDENTIFICATION LIST

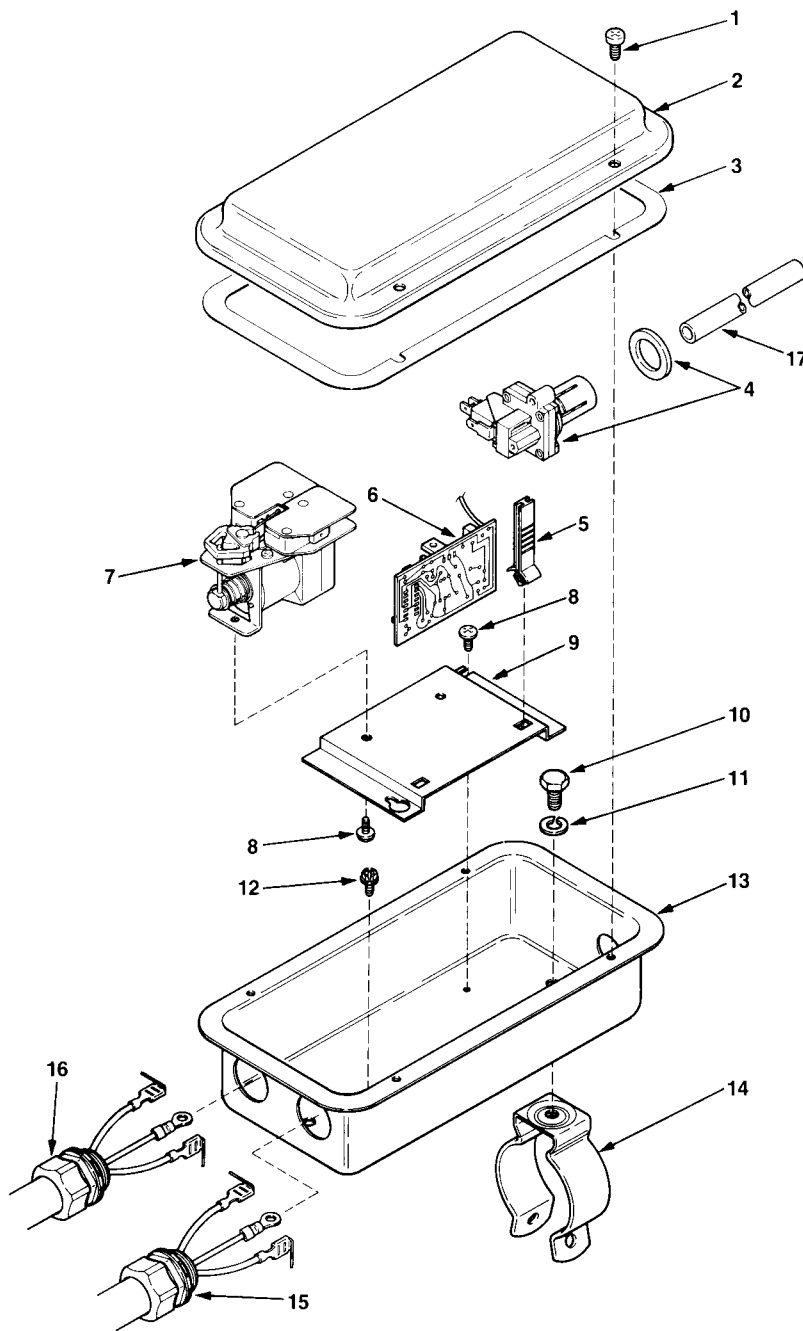

Item No.	Description	Quantity	Item No.	Description	Quantity
1	Screw	4	10	Bolt	2
2	Cover	1	11	Washer	2
3	Gasket	1	12	Screw	1
4	Air Switch Assembly	1	13	Enclosure	1
5	Holder	2	14	Hanger	2
6	PC Board (Timer)	1	15	Cable Assembly	1
7	Relay	1	16	Cable Assembly	1
8	Screw	4	17	Air Switch Tube	1
9	Mounting Bracket	1			

Figure 4-1. Power Panel Assembly

SECTION 5— MOTOR AND PUMP

THEORY OF OPERATION

The motor and pump work as a unit; the motor provides the drive power for the pump impeller.

The whirling action of the impeller creates a vacuum, pulling water into the inlet port. The incoming water is forced through the impeller and out through the water harness.

Adjustable jets, located on the sides of the tub, provide outlets for the circulating water and serve to divert the flow of the water for more effective whirlpool action.

Figures 5-1 and 5-2 illustrate how air is aspirated into the water stream as the water passes through the adjustable jets. The amount of air mixed with the water is controlled by the two adjustable air aspirators located on top of the tub.

SERVICING THE MOTOR AND PUMP

The motor and pump should be removed from the Whirlpool Bath for all service and maintenance activities. Removal and replacement can be accomplished using the following procedure:

WARNING: Turn GFCI OFF.

1. Disconnect pump from suction and harness tubes.
CAUTION: Be careful not to strip threads on studs.
2. Remove bolts or nuts and washers securing motor and pump to tub.
3. Remove motor and pump.
4. Disconnect motor power cord leads from air switch power module at the motor.
5. Replace in reverse order.

Once the motor and pump has been removed, determine which model had been installed. Follow service procedures for that model only.

KOHLER MODELS 60660-M, AND 60661-M MOTOR AND PUMP

These models are 1/2 horsepower assemblies, identical in all aspects except for casing alignment with motor body. (For right or left outlet installation.)

The Kohler 60660-M or 60661-M motor and pump can be disassembled for service using the following procedure (refer to Figure 5-3):

1. Remove screws securing pump casing to seal plate. Remove casing.
2. Hold motor shaft by inserting a screwdriver into slot provided in motor casing; or remove motor

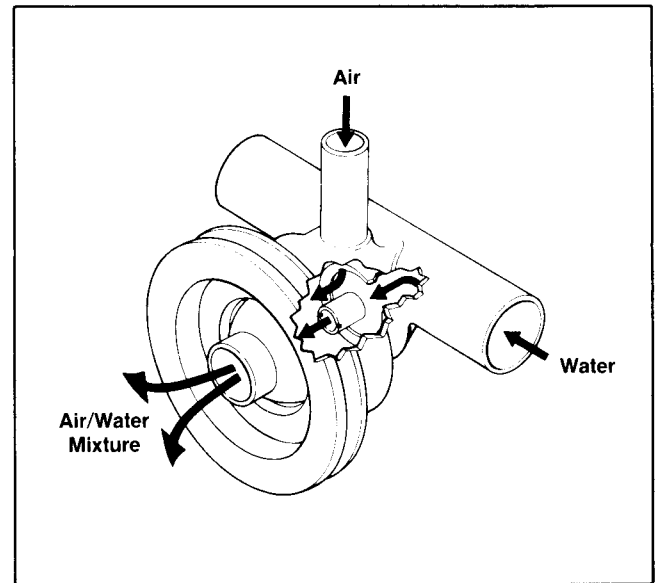

Figure 5-1. Water/Air Mixture - Brass Whirlpool System

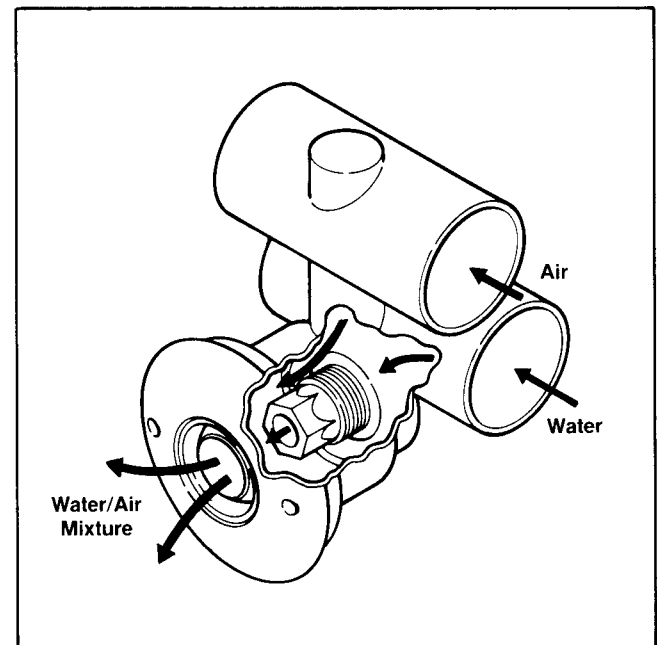

Figure 5-2. Water/Air Mixture - Plastic Whirlpool System

end cover and hold shaft with an open end wrench.

3. Rotate impeller counterclockwise and remove.
4. Slide rotating member of seal assembly off impeller shaft.
5. Remove seal plate O-ring.
6. Remove seal plate from motor housing.
7. Remove stationary members of seal assembly by pushing out from behind plate.

CAUTION: Use only fingers, not a screwdriver or other sharp object which may damage components.

8. Check impeller, O-ring and seal assembly. If any item is damaged or worn, replace it. Impeller and casing are a matched pair; replace both at the same time.
9. Clean impeller hub and all seal assembly cavity surfaces.
10. Install seal plate on motor housing.
11. Install stationary members of seal assembly into face plate. Lubricate O-ring with clean water only.

CAUTION: When installing seal assembly mem-

bers, do not use a screwdriver or other sharp object which may damage ceramic ring.

12. Seat stationary members firmly using finger pressure only.
13. Slide rotating member of seal assembly onto impeller shaft. Lubricate with clean water only.
14. Ensure grooved portions of rotating member are located over raised portions of impeller shaft.
15. Hand tighten impeller onto motor shaft.
16. Install O-ring on seal plate.
17. Replace pump casing and secure in place.

COMPONENT IDENTIFICATION LIST

Kohler Models 60660-M and 60661-M Motor and Pump

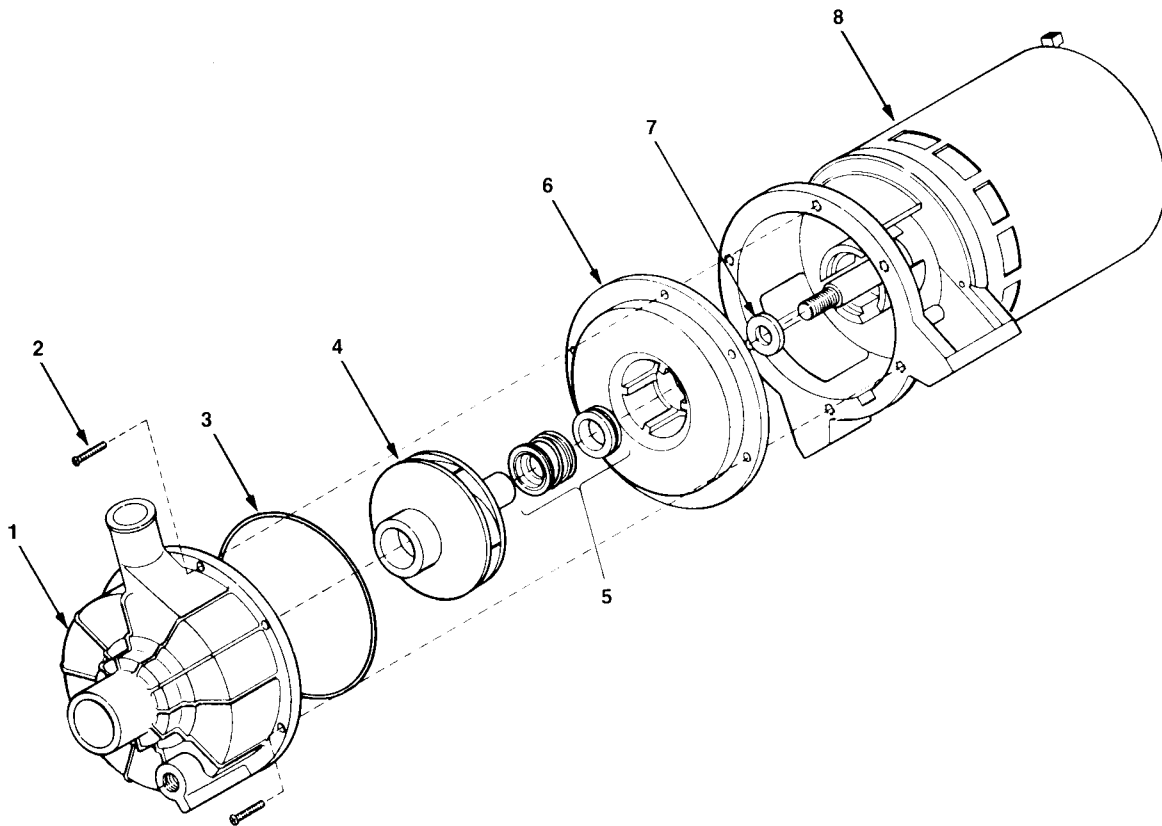

Item No.	Description	Quantity	Item No.	Description	Quantity
1	Casing	1	5	Pump Seals	1
2	Screw	6	6	Seal Plate	1
3	O-Ring	1	7	Slinger	1
4	Impeller	1	8	Motor	1

Figure 5-3. Motor and Pump

KOHLER MODELS 60660-H, AND 60661-H MOTOR AND PUMP

These models are 1/2 horsepower assemblies, identical in all aspects except for casing alignment with motor body. (For right or left outlet installation.)

The Kohler 60660-H or 60661-H motor and pump can be disassembled for service using the following procedure (refer to Figure 5-4):

1. Remove screws securing pump casing to face plate. Remove casing.
2. Hold motor shaft by inserting a screwdriver into slot provided in motor casing; or remove motor end cap and hold shaft with an open end wrench.
3. Rotate impeller counterclockwise and remove.
4. Slide rotating member of seal assembly off impeller shaft.
5. Remove motor end cap.
6. Remove screws securing face plate to motor housing.
7. Remove stationary members of seal assembly by pushing out from behind face plate.
CAUTION: Use only fingers, not a screwdriver or other sharp object which may damage components.
8. Remove slinger from motor shaft.

9. Check impeller, O-ring, shaft sleeve, and seal assembly. If any item is damaged or worn, replace it. Impeller and casing are a matched pair; replace both at the same time.
10. Clean impeller hub and all seal cavity surfaces.
11. Install slinger on motor shaft. Ensure that flange of slinger is facing threaded end of shaft.
12. Install O-ring on ceramic seal member. Ensure it is properly seated.
13. Press ceramic ring into clear plastic retainer.
14. Attach face plate to motor housing.
15. Install O-ring on cut ridge of clear plastic retainer.
CAUTION: When installing seal assembly members, do not use a screwdriver or other sharp object which may damage components.
16. Press assembled stationary members of seal assembly into face plate. Lubricate with clean water only. Seal assembly should be pressed in with O-ring toward motor and exposed face of the ceramic ring toward impeller.
17. Slide rotating member of seal assembly onto impeller shaft. Lubricate with clean water only.
18. Hand tighten impeller onto motor shaft.
19. Install O-ring on face plate.
20. Replace pump casing and secure in place.

COMPONENT IDENTIFICATION LIST

Kohler Models 60660-H and 60661-H Motor and Pump

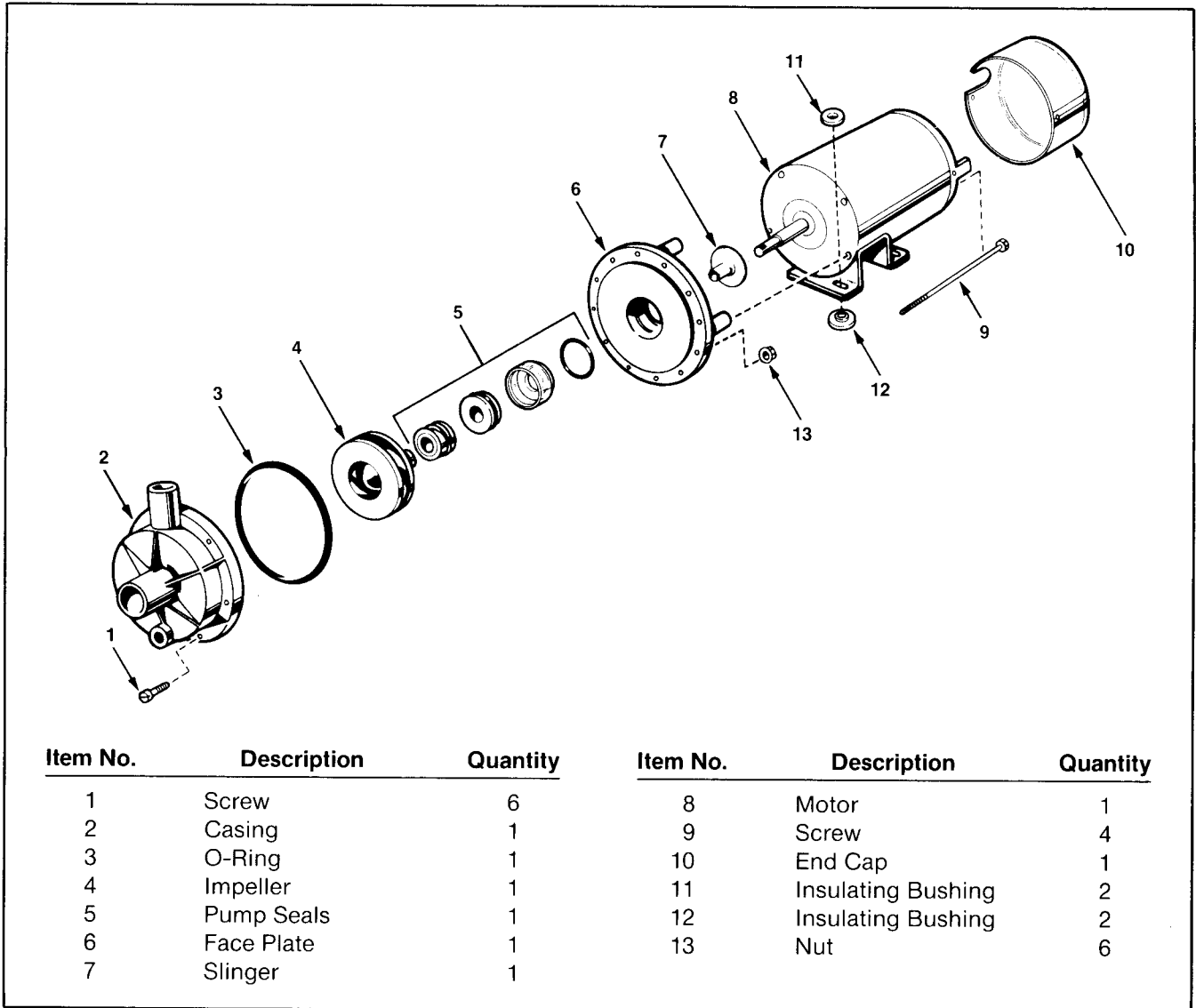

Item No.	Description	Quantity	Item No.	Description	Quantity
1	Screw	6	8	Motor	1
2	Casing	1	9	Screw	4
3	O-Ring	1	10	End Cap	1
4	Impeller	1	11	Insulating Bushing	2
5	Pump Seals	1	12	Insulating Bushing	2
6	Face Plate	1	13	Nut	6
7	Slinger	1			

Figure 5-4. Motor and Pump

KOHLER MODELS 60662-M, AND 60663-M MOTOR AND PUMP

These models are 3/4 horsepower assemblies, identical in all aspects except for casing alignment with motor body. (For right or left outlet installation.)

The Kohler Model 60662-M or 60663-M motor and pump can be disassembled for service using the same procedures outlined for disassembly and service as the 60660-M and 60661-M. See page 13 of this manual.

COMPONENT IDENTIFICATION LIST

Kohler Models 60662-M and 60663-M Motor and Pump

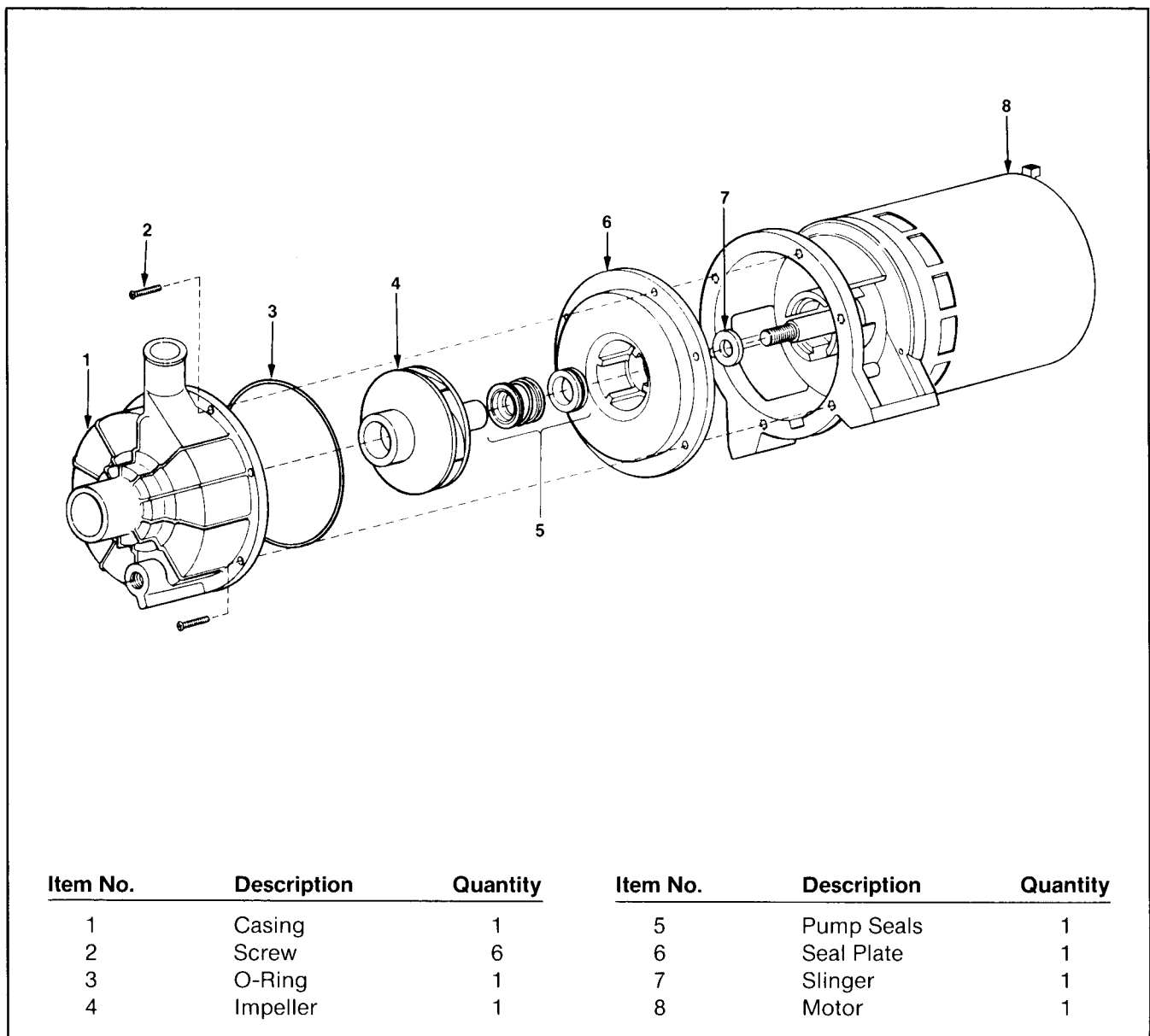

Figure 5-5. Motor and Pump

KOHLER MODEL 60388-M MOTOR AND PUMP

This model is a 1 horsepower assembly.

The Kohler Model 60388-M motor and pump can be disassembled for service using the following procedure (refer to Figure 5-6):

1. Remove screws securing casing to motor. Remove casing.
2. Lift off diffuser and gasket.
3. Hold motor shaft by inserting screwdriver into slot provided in motor casing; or remove motor end cover and hold shaft with an open end wrench.
4. Rotate impeller counterclockwise and remove.
5. Slide rotating member of seal assembly off impeller shaft.
6. Remove diffuser O-ring and face plate gasket.
7. Remove screws and lockwashers securing face plate and bracket to motor housing. Remove face plate and bracket.
8. Remove stationary members of seal assembly by pushing out from behind face plate and bracket.

CAUTION: Use only fingers, not a screwdriver or other sharp object which may damage components.

9. Check impeller, diffuser, diffuser O-ring, gasket,

and all pump seals. If any item is damaged or worn, replace it. Impeller, casing, and diffuser are a matched set; replace at the same time.

10. Clean impeller and all seal assembly cavity surfaces thoroughly before reassembling.
11. Secure face plate to motor housing.
12. Install stationary members of seal assembly into the face plate. Lubricate gasket with clean water only.
CAUTION: When installing seal assembly members, do not use a screwdriver or other sharp object which may damage ceramic ring.
13. Seat stationary members firmly, using finger pressure only.
14. Slide rotating member of seal assembly onto impeller shaft. Lubricate with clean water only.
15. Ensure grooved portions of rotating member are located over raised portions of impeller shaft.
16. Hand tighten impeller onto motor shaft.
17. Place diffuser over impeller with word "TOP" at top. Stop lug will be in 6 o'clock position. Ensure the O-ring is securely in place.
18. Lubricate with water. Then place gasket in groove on face plate and bracket. Ensure gasket is sealed properly.
19. Replace pump casing and secure in place.

COMPONENT IDENTIFICATION LIST

Kohler Model 60388-M Motor and Pump

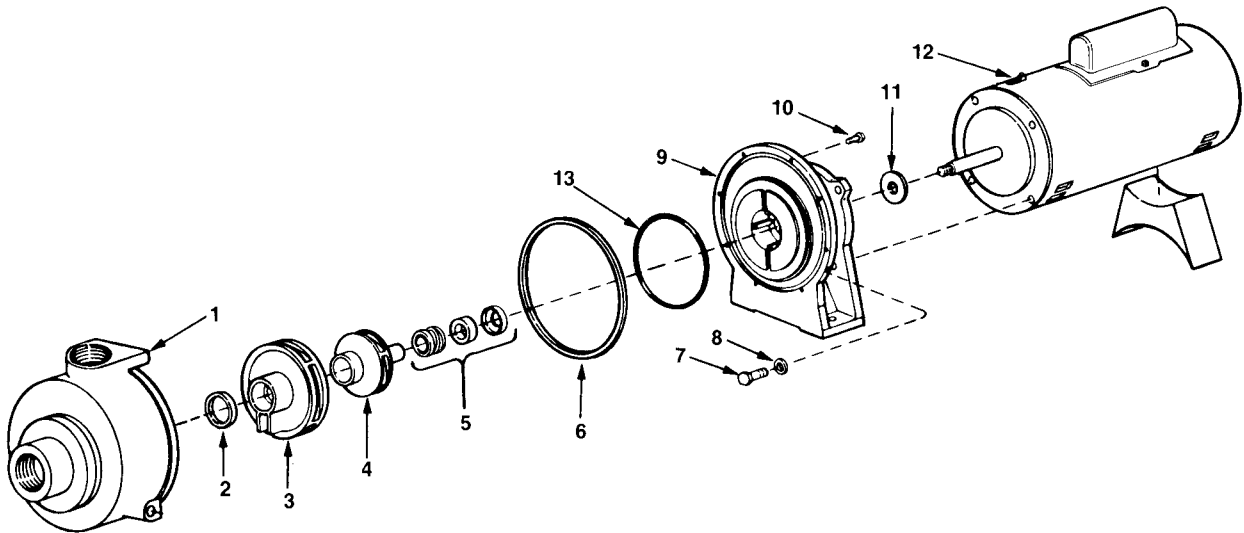

Item No.	Description	Quantity	Item No.	Description	Quantity
1	Casing	1	8	Washer	4
2	Gasket	1	9	Face Plate, Bracket	1
3	Diffuser	1	10	Screw	8
4	Impeller	1	11	Slinger	1
5	Pump Seals	1	12	Motor	1
6	Gasket	1	13	O-Ring	1
7	Screw	4			

Figure 5-6. Motor and Pump

SECTION 6— TRIM KITS

SERVICING THE TRIM KITS

Trim kit components are designed for long life. However, if one needs to be replaced, use the following procedures:

Adjustable Jets (Brass)

The adjustable jets are serviced using the following procedure (refer to Figure 6-1):

1. Remove two screws securing retainer to jet housing.
2. Pull on center of ball and remove assembly from housing. Assembly may be tightly sealed. If necessary, use small Phillips screwdriver in screw hole to remove assembly.
3. Disassemble assembly into ball, O-ring, retainer, and plastic insert bearing.
4. Remove trim ring only if it is damaged. It may be sealed with RTV sealant.
5. Replace parts as required and clean all surfaces before reassembly.
6. If trim ring is removed and replaced, remove dirt, grease, moisture, and RTV from jet housing flange.
7. Apply RTV sealant to underside lip of trim ring.
8. Carefully snap trim ring into flange on tub. Ensure that dimples in trim ring align with notches in jet housing.
9. Apply light film of lubricant to two O-rings and plastic insert bearing.
10. Install O-rings on retainer. One is installed inside, the other in groove on outside of retainer.
11. Assemble ball and plastic insert bearing into retainer.
12. Insert ball and retainer into jet housing, being careful not to drop plastic bearing into housing.
13. Align screw holes and secure retainer to jet housing.
14. Tighten screws until ball moves freely with slight side to side pressure.

Suction Inlet (Brass)

The water suction inlet is serviced using the following procedure (refer to Figure 6-1):

1. Remove screw securing suction hood and screen to inlet housing.
2. Remove hood and hair screen.

3. Replace any parts as necessary and clean all surfaces before reassembly.
4. Fit hair screen into groove on back of hood.
5. Attach screen and hood squarely to inlet housing. Ensure riveted portion of screen is located toward bottom of tub.
6. Secure hood and screen into place.

Adjustable Jets (Plastic)

The adjustable jets are serviced using the following procedure (refer to Figure 6-2):

1. Using a small screwdriver loosen the ball lock ring.
2. Remove ball and lock ring from jet housing.
3. Using a 9/16 inch socket wrench remove the orifice from the jet housing.
4. Replace parts as required and clean all surfaces before reassembly.
5. Assemble orifice into jet housing.
6. Assemble ball and ball lock ring into jet housing. Tighten with small screwdriver.

NOTE: See Section 7 for expanded service of Plastic Jets and Suction.

Suction Inlet (Plastic)

The water suction inlet is serviced using the following procedure (refer to Figure 6-2):

1. Remove screw securing suction hood to inlet housing.
2. Remove hood from inlet housing by unscrewing hood counterclockwise.
3. Replace any parts as necessary and clean all surfaces before reassembly.
4. Secure hood into place.
5. Install screw securing suction head to inlet housing.

WARNING: The whirlpool must not be operated without the suction hood installed.

NOTE: See Section 7 for expanded service of Plastic Jets and Suction.

SERVICING THE ASPIRATOR ASSEMBLY

Refer to **SECTION 3 — SERVICING THE ACTUATOR/ASPIRATOR ASSEMBLY**. Omit references to the air bellows. All other service procedures are the same.

COMPONENT IDENTIFICATION LIST (BRASS)

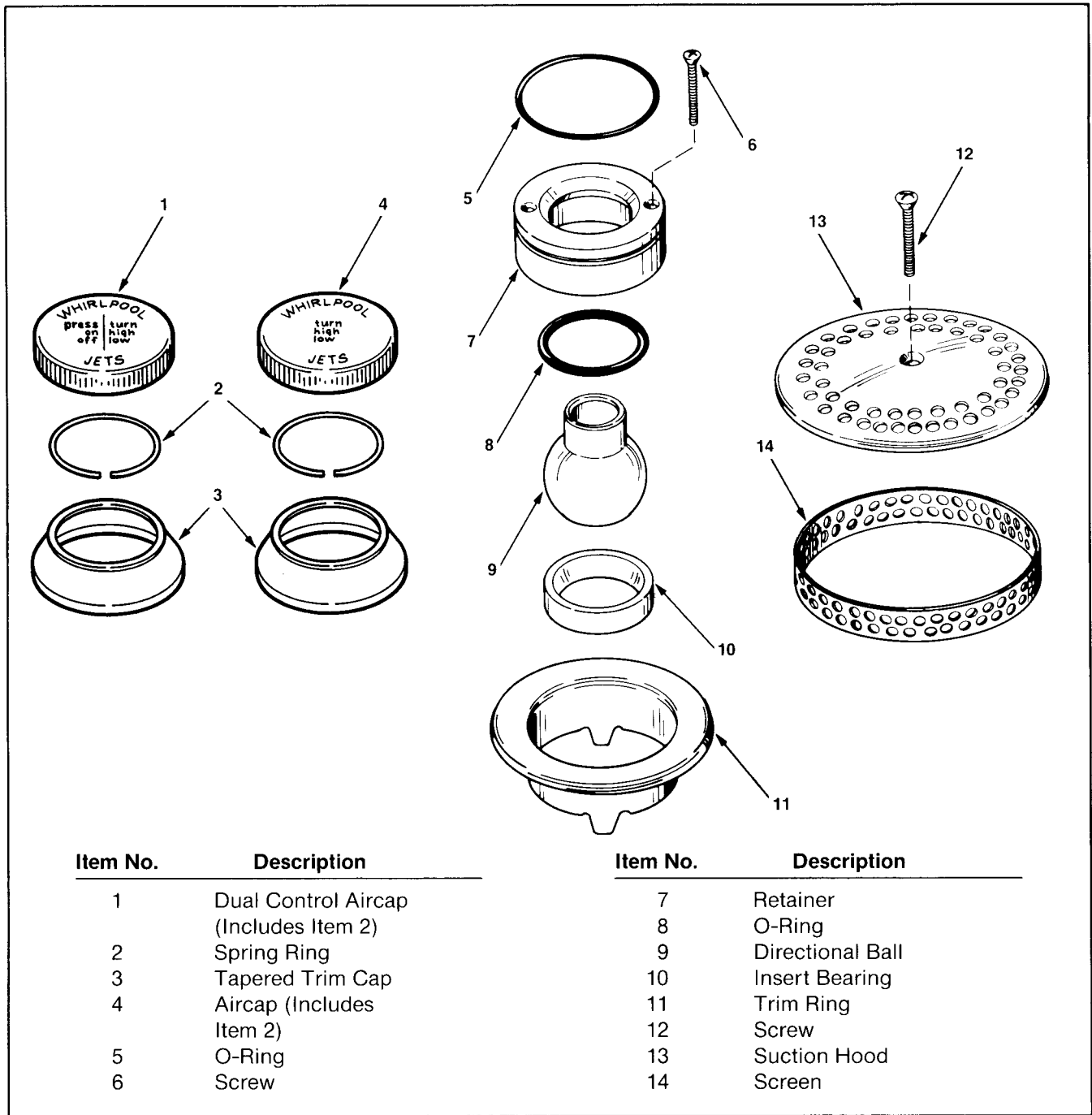
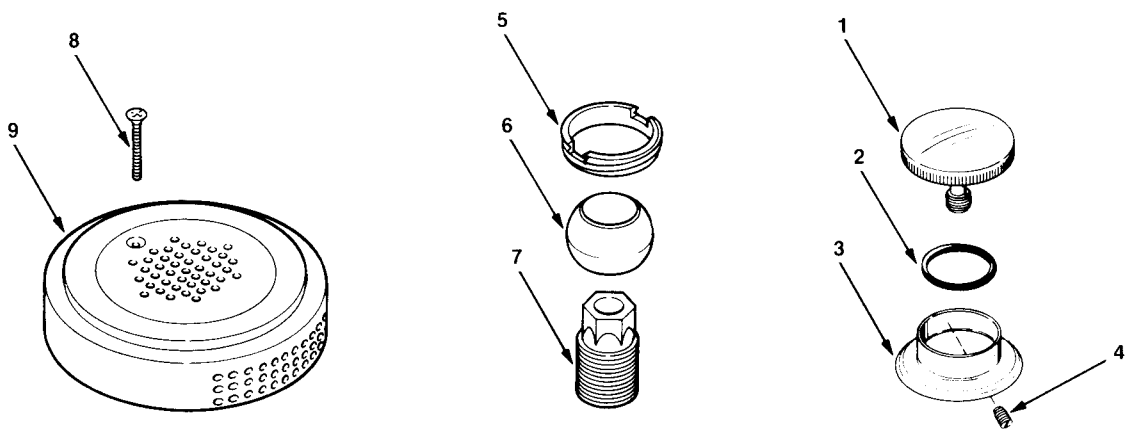

Figure 6-1. Trim Kits

COMPONENT IDENTIFICATION LIST (PLASTIC)



<u>Item No.</u>	<u>Description</u>	<u>Quantity</u>	<u>Item No.</u>	<u>Description</u>	<u>Quantity</u>
1	Control Knob	1	6	Adjustable Ball	4
2	O-Ring	1	7	Orifice	4
3	Trim Cap	1	8	Screw	1
4	Setscrew	1	9	Suction Hood	1
5	Ball Retaining Ring	4			

Figure 6-2. Trim Kits

SECTION 7— PLASTIC JET AND SUCTION SERVICE

SERVICING PLASTIC JET ASSEMBLY AND SUCTION ASSEMBLY

Kits are available through your Kohler Service Parts Supplier which include the components illustrated in Figures 7-1 and 7-2. Also included are adjacent fittings and short pieces of flexible PVC tubing.

To service the jet and suction assemblies using the repair kits, follow these procedures:

1. Analyze the damaged jet, adjacent fittings, and tube diameters. Choose the parts in the kit needed for the repair job.
2. Provide suitable protection for acrylic surfaces of the bath.

3. Remove all attachments to the wall fitting (flange) including ball and retainer assembly or suction hood cover.
4. Remove the wall fitting (flange) with a jet spanner wrench and ratchet/socket by turning counterclockwise. Make sure there is complete engagement of the wrench pins in the wall flange sockets to prevent damage to flange or bath walls.
5. Cut all water and air supply tubes to damaged jet housing.

CAUTION: DO NOT CUT ANY CLOSER THAN 3" FROM THE JET.

COMPONENT IDENTIFICATION LIST

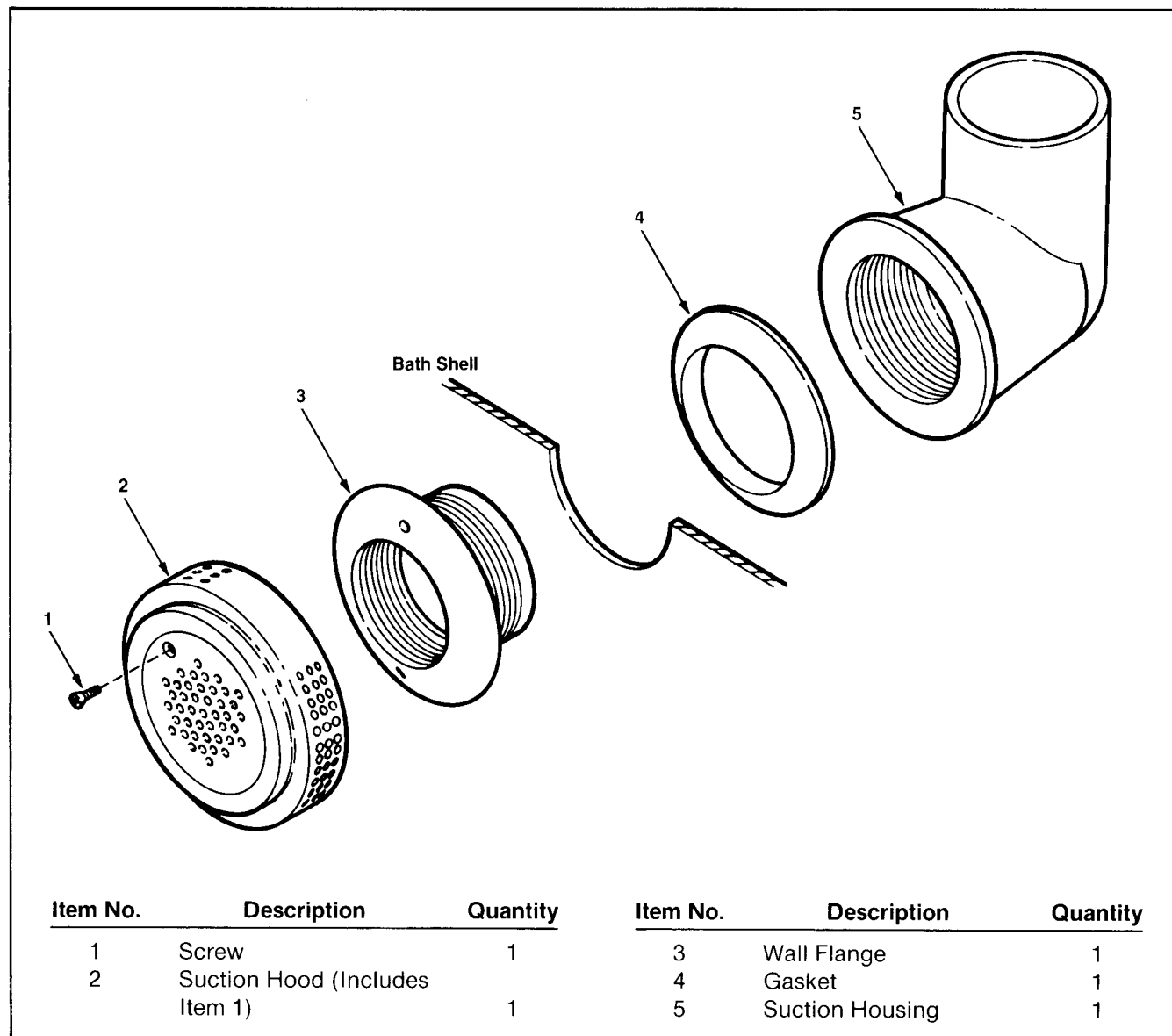

Figure 7-1. Suction Assembly

COMPONENT IDENTIFICATION LIST

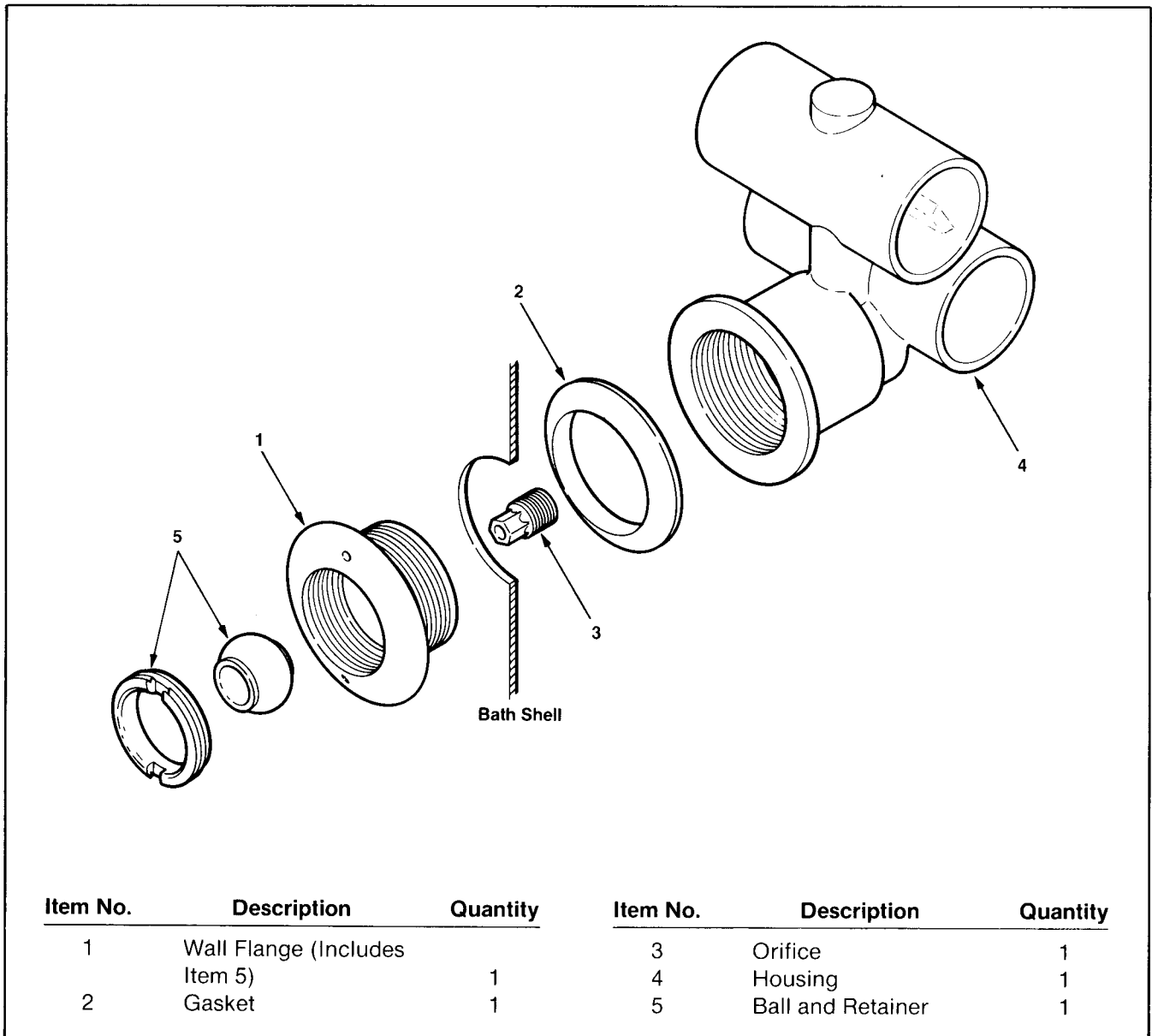

Figure 7-2. Jet Assembly

6. Salvage and clean all removed parts including beveled gasket, wall flange, jet orifice, and orifice insert for possible reuse. Inspect thoroughly for damage before reusing. Clean all old RTV silicone sealant from hole.
7. Using the PVC primer and cement (follow the manufacturer's instructions), install suitable tube couplings to the cut ends of the air or water supply tubes.
8. Clean and cement suitable reducing bushings, plugs, or adapters to the new jet or suction housing. Place the new housing over the hole and determine the proper length of flexible tubing required to bridge the distance between the jet and water and air supply tubes.
9. Cut lengths of flexible tubing allowing enough length for complete seating in the jet and coupling sockets.
10. Slip fit the flexible tubes and temporarily install the housing to the wall flange (without gluing or sealing) to ensure that your measurements are correct.
11. Keep the housing aligned with the hole and cement the tubes to the housing and couplings.
12. Reinstall the wall flange to the housing with the gasket behind the bath wall (beveled edge to the wall). Draw a bead of silicone around the flange being sure to avoid the threads. Thread the flange into the housing. Before tightening completely,

apply a bead of silicone sealant between the rear bath wall and the beveled side of the gasket. Complete tightening until the gasket begins to compress.

CAUTION: DO NOT OVERTIGHTEN.

If the gasket pops out, loosen the wall flange and repeat the process.

13. Wipe away excess silicone from the inside of the bath wall and apply silicone around the housing at the rear of the unit. Clean the inside of the unit before silicone cures.
14. Make sure that you have installed the correct orifice insert into the new housing.
15. Replace the wall fitting attachments. For example: ball and retainer, or suction cover.
16. Allow 3 hours for a complete cure of silicone and PVC cement before testing.

SERVICE NOTE

K-1512 "SA" Hourglass Whirlpools and K-1492 "SA" Greek Whirlpools are still equipped with air actuator assemblies shown in Figure 7-3. Refer to: KOHLER WHIRLPOOL SERVICE MANUAL No. 105583 for actuator service instructions.

COMPONENT IDENTIFICATION LIST

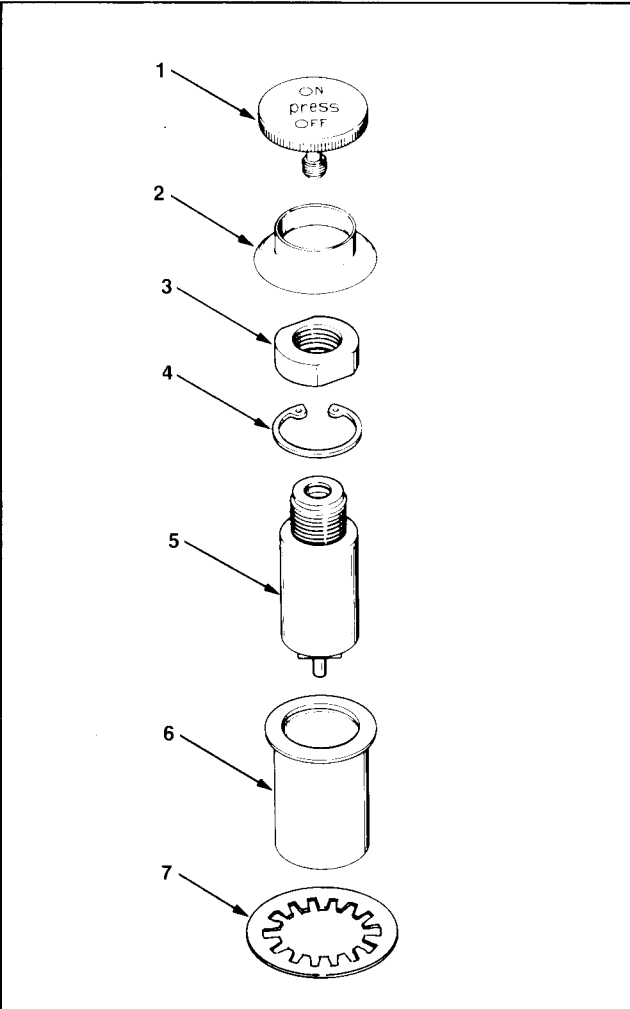

The diagram shows an exploded view of an actuator assembly. The components are numbered as follows: 1. Knob with 'ON press OFF' text; 2. Trim Cap; 3. Collar; 4. C-Clip; 5. Actuator; 6. Housing; 7. Fastener.

Item No.	Description	Quantity
1	Knob	1
2	Trim Cap	1
3	Collar	1
4	C-Clip	1
5	Actuator	1
6	Housing	1
7	Fastener	1

Figure 7-3. Actuator Assembly

Limited One-Year Warranty

Kohler plumbing fixtures and fittings are warranted free of manufacturing defects.

Kohler Co. will at its election repair, replace or make appropriate adjustment where Kohler Co. inspection discloses any such defects occurring in normal usage within one year after installation. **Kohler Co. is not responsible for installation costs.**

To obtain warranty service, contact Kohler Co. either through your Dealer or Plumbing Contractor or by writing Kohler Co., Attn: Consumer Affairs Department, Kohler, Wisconsin 53044 U.S.A.

Implied warranties including that of merchantability are expressly limited in duration to the duration of this warranty. Kohler Co. disclaims any responsibility for consequential damages. Some states do not allow limitations on how long an implied warranty lasts, or the exclusion or limitation of incidental or consequential damages, so this limitation and exclusion may not apply to you. This warranty gives you specific legal rights. You may also have other rights which vary from state to state.

This is our exclusive written warranty.

KOHLER

KOHLER CO. KOHLER, WISCONSIN 53044