

nova™ 536 whirlpool bath and soaking bath

nova—a brightly burning star. the nova™ whirlpool bath—a rejuvenating point of light in your day, your night, your routine.



Clean lined and classic, the Nova™ whirlpool is versatility defined.

features:

- 4 Fully adjustable TheraPro™ jets
- 2 Directionally adjustable AccuPro™ lumbar jets
- Sculpted armrest
- Contoured backrest
- Handrails
- Exclusive Tru-Level™ base system
- Slip-resistant bottom
- Patented Silent Air™ Induction system
- Electronic controls
- Drain included on whirlpool baths

nova™ 536 whirlpool bath

model number: H532 – RH, H531 – LH

exterior dimensions:
60" long x 36" wide x 19¼" high

interior dimensions (at bottom):
34½" long x 22" wide(mid) x 14" wide (end)

of Jets/type of Jets:
4 TheraPro™ Jets
2 AccuPro™ Jets

operating gallons:
42 gallons

nova™ 536 soaking bath

model number: H533

exterior dimensions:
60" long x 36" wide x 19¼" high

interior dimensions:
34½" long x 22" wide





Nova® 536 Whirlpool Bath

Model: H531, H532

Nova® 536 Bath

Model: H533

Ordering Information

Product Code:

H532 Nova® 536 Whirlpool Bath

Right Hand

H531 Nova® 536 Whirlpool Bath

Left Hand

H533 Nova® 536 Bath

- Right and Left Hand Drain Location
- Accessories / Hardware:
 - Trip-Lever Drain Kit #X559
 - Rotary Drain Kit, 26" Cable #8730
 - HTC Jet Trim Kit: #D095
 - BMH Jet Trim Kit: #J869
- Trim Kit Finishes Available:
 - (827) - Chrome
 - (898) - Brushed Chrome
 - (815) - Satin Nickel
 - (829) - Bright Brass
 - (805) - Platinum
 - (826) - Brushed Nickel
 - (849) - Oil Rubbed Bronze

Installation Notes

Refer to installation instructions included with fixture before beginning installation. Please confirm product availability and specifications before commencing with any installation work.

PRODUCT SPECIFICATIONS AND AVAILABILITY ARE SUBJECT TO CHANGE WITHOUT NOTICE.

Electrical Components and Electrical Specifications do not apply to non-jetted baths.

Technical Specifications

Dimensions

60" L x 36" W x 19-1/4" H
(1524 mm) L x (914 mm) W x (489 mm) H

Drain/Overflow

A: 15-1/8" (384 mm) B: 9" (229 mm)

Cutout

58" x 34"

Total Weight

H531, H532: 683 lb (310 kg) / 46 lb/ft² (222 kg/m²)
H533: 660 lb (299 kg) / 44 lb/ft² (215 kg/m²)

Operating Gallonage

42 U.S. Gal. (159 Liters)

Product Weight

H531, H532: 83 lb (38 kg)
H533: 60 lb (27 kg)

Skirt Mounting

Not Available

Electrical Specifications Models H531, H532 only

Requires a dedicated GFCI protected separate circuit.

Motor/Pump: 120 VAC, 15 AMP, 60 Hz.

RapidHeat™: 120 VAC, 15 AMP, 60 Hz.

Heater (Optional Models H531, H532 only)

Requires a dedicated GFCI protected separate circuit.

RapidHeat™: P/N S750000

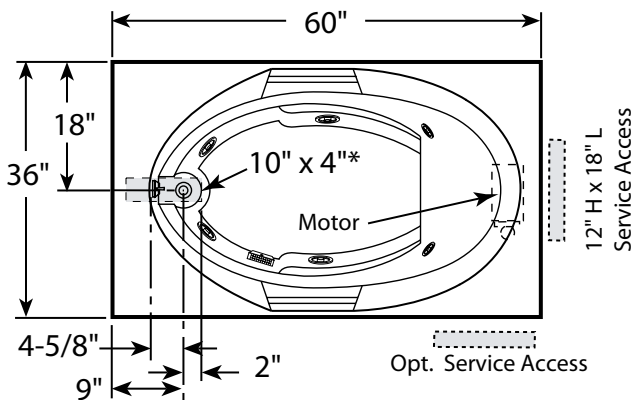

Product Shown: Nova® 536 Whirlpool Bath Left Hand Model: H531

* Measurements inside unit represent cutout in floor to allow for drain/overflow.

Minimum Service Access dimensions given.

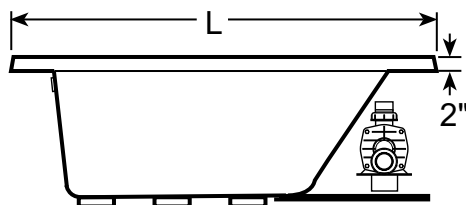

SIDE VIEW

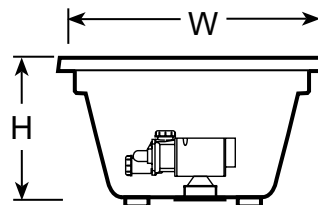

END VIEW

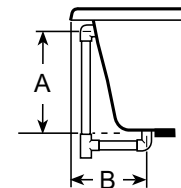

DRAIN/OVERFLOW