



Evoking the breathtaking beauty and ancient maritime tradition of the northern Italian town for which it is named, the Riva® is true to form—an elegant classic. And truly versatile—at home in both traditional and more contemporary interior design.

WHIRLPOOL BATH FEATURES:

- Contoured backrest
- 4 Fully adjustable TheraPro™ jets
- 2 Directionally adjustable AccuPro™ lumbar jets
- 2 Directionally-adjustable AccuPro™ foot jets
- 256-color chromatherapy underwater lighting
- Exclusive Tru-Level™ base system
- Slip-resistant bottom
- Patented Fixed Silent Air™ Induction system
- RapidHeat™ inline heater

**Riva® 5.5
WHIRLPOOL PLUS**

MODEL NUMBER:

FX05 – Right-hand
FX00 – Left-hand

EXTERIOR DIMENSIONS:

66" long x 38" wide x
19½" high

OF JETS/TYPE OF JETS:

4 TheraPro™ Jets
4 AccuPro™ Jets

OPERATING GALLONS:

50 gallons





Riva® 5.5 WHIRLPOOL PLUS

FX05	Riva™ 5.5 Whirlpool Plus, Right Hand
FX00	Riva™ 5.5 Whirlpool Plus, Left Hand

- Left and Right Hand Drain Location
- Accessories / Hardware:
 - Rotary Drain Kit, 26" Cable #8730
- Trim Kit Finishes Available:
 - (827) – Chrome
 - (898) – Brushed Chrome
 - (815) – Satin Nickel
 - (829) – Bright Brass
 - (805) – Platinum
 - (826) – Brushed Nickel
 - (849) – Oil Rubbed Bronze

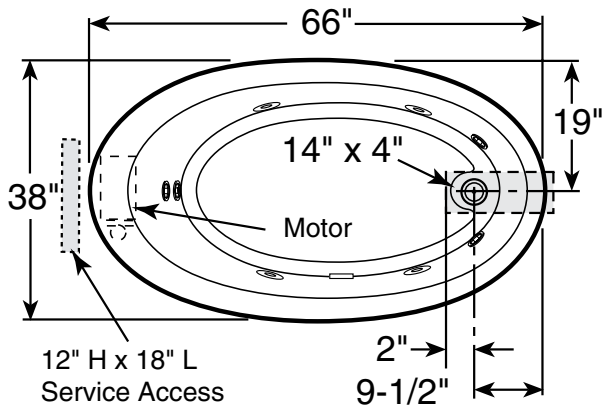

**Product Shown: Riva® 5.5 Whirlpool Plus
Right Hand Shown Model: FX05**

** Measurements inside unit represent cutout in floor to allow for drain/overflow.*

Minimum Service Access dimensions given.

INSTALLATION NOTES

Refer to installation instructions included with fixture before beginning installation. Please confirm product availability and specifications before commencing with any installation work.

PRODUCT SPECIFICATIONS AND AVAILABILITY ARE SUBJECT TO CHANGE WITHOUT NOTICE.

Technical Specifications

EXTERIOR DIMENSIONS

66" L x 38" W x 19 1/2" H
(1676 mm) L x (965 mm) W x (495 mm) H

INTERIOR DIMENSIONS

45" L x 25" W x 16" H
(1143 mm) L x (635 mm) W x (406 mm) H

DRAIN/OVERFLOW

A: 14 3/4" (375 mm) B: 9 1/2" (241 mm)

CUTOUT

Template Provided Part Number:
FX40000 Drop-in/Undermount

TOTAL WEIGHT

760 lb (344 kg) / 55 lb/sq. ft. (29 kg/m²)

OPERATING GALLONAGE

50 U.S. Gal. (189 Liters)
Min. 44 U.S. Gal. (166 Liters)
Max. 56 U.S. Gal. (211 Liters)

PRODUCT WEIGHT

93 lb (42 kg)

SKIRT MOUNTING

Not Available

ELECTRICAL SPECIFICATIONS

Requires a dedicated GFCI protected separate circuit.

Motor/Pump: 120 VAC, 15 AMP, 60 Hz.

RapidHeat™: 120 VAC, 15 AMP, 60 Hz.

HEATER

Requires a dedicated GFCI protected separate circuit.

RapidHeat™: P/N S750000

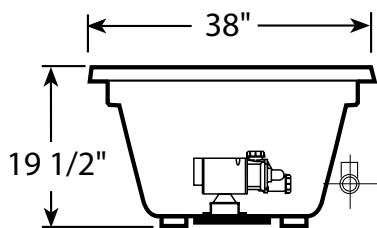

END VIEW

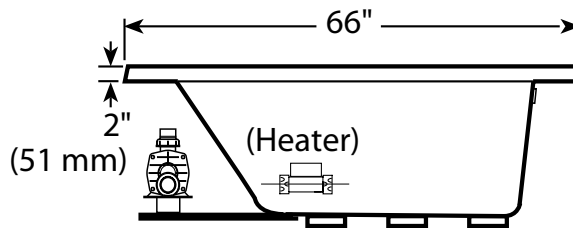

SIDE VIEW

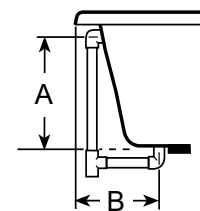

DRAIN/OVERFLOW