



In Italy, it means beautiful view. To you, a wonderful place to regain relaxed, revitalized perspective. Set aside one corner of your world as a corner of renewal the Bellavista.™

FEATURES:

- Multi-speed motor
- 4 fully adjustable PowerPro® jets
- 4 spinning neck jets
- 2 AccuPro™ jets
- 900 watt variable speed heated air blower
- Bottom air channels for maximum massage
- Chromatherapy™ lighting system capable of 256 colors
- All-in-one electronic control panel
- Drain-assist purge system
- RapidHeat™ inline heater
- ProO₃™ Cleansing System

Detail: The Bellavista™ Salon™ Spa's perfectly placed PowerPro® and AccuPro™ jets work in concert with a deeply contoured backrest to offer the ultimate in hydrotherapy.

**Bellavista™
CORNER
SALON™ SPA**

MODEL NUMBER:
DT20

EXTERIOR DIMENSIONS:
60" long x 60" wide x
25" high

INTERIOR DIMENSIONS:
41" long x 34" wide

OF JETS/TYPE OF JETS:
4 PowerPro® Jets
4 AccuPro™ Neck Jets
2 AccuPro™ Foot Jets

OPERATING GALLONS:
83-91 gallons





Bellavista™ CORNER SALON™ SPA BATH

DT20

Bellavista™ Corner Salon™ Spa with RapidHeat™
Right Hand

- Center Drain Location
- Accessories / Hardware:
 - PowerPro™ Jet Rings Kit: #M952
 - 3 x AccuPro™ Jet Rings Kit: #P556
 - Rotary Drain Kit, 26" Cable: #DA34
- Trim Kit Finishes Available:
 - (827) – Chrome
 - (898) – Brushed Chrome
 - (815) – Satin Nickel
 - (829) – Bright Brass
 - (805) – Platinum
 - (826) – Brushed Nickel
 - (849) – Oil Rubbed Bronze

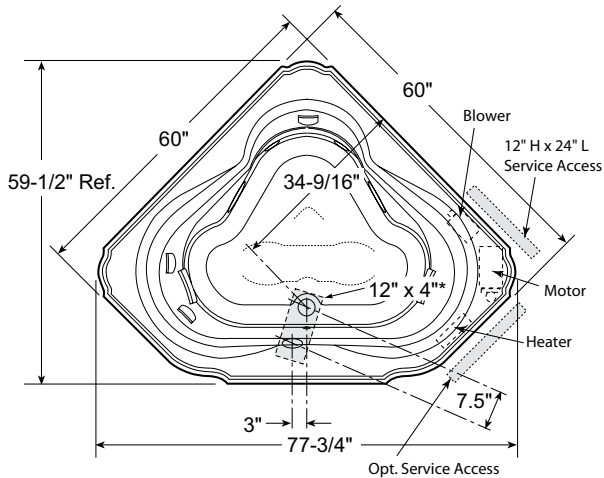

Product Shown: Bellavista™ Corner Salon™ Spa, Model: DT20

* Measurements inside unit represent cutout in floor to allow for drain/overflow.

Minimum Service Access dimensions given.

INSTALLATION NOTES

Refer to installation instructions included with fixture before beginning installation. Please confirm product availability and specifications before commencing with any installation work.

PRODUCT SPECIFICATIONS AND AVAILABILITY ARE SUBJECT TO CHANGE WITHOUT NOTICE.

Technical Specifications

DIMENSIONS

60" L x 60" W x 25" H
(1524 mm) L x (1524 mm) W x (635 mm) H

DRAIN/OVERFLOW

A: 18-7/8" (479 mm) B: 14" (356 mm)

CUTOUT

Template Provided P/N P654000

TOTAL WEIGHT

1165 lb (528 kg) / 49.6 lb/ft² (242) kg/m²

OPERATING GALLONAGE

87 U.S. Gal. (329 Liters)
Min. 83 U.S. Gal. (314 Liters)
Max. 91 U.S. Gal. (344 Liters)

PRODUCT WEIGHT

197 lb (89 kg)

SKIRT MOUNTING

Not Available

ELECTRICAL SPECIFICATIONS

Requires a dedicated GFCI protected separate circuit.

Blower: 120VAC, 20AMP, 60 Hz
Motor/Pump and RapidHeat™: 240VAC, 20AMP, 60 Hz.

HEATER (STANDARD)

Requires a dedicated GFCI protected separate circuit.

RapidHeat™: P/N BN60000

