

Installation Instructions / Warranty

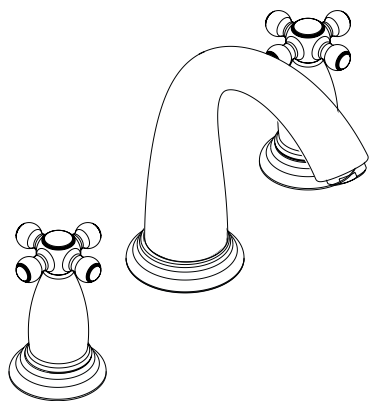

3-Hole Roman Tub Rough
3-Hole Roman Tub Trim Kits

hansgrohe

3-Hole Roman Tub Rough

06607000

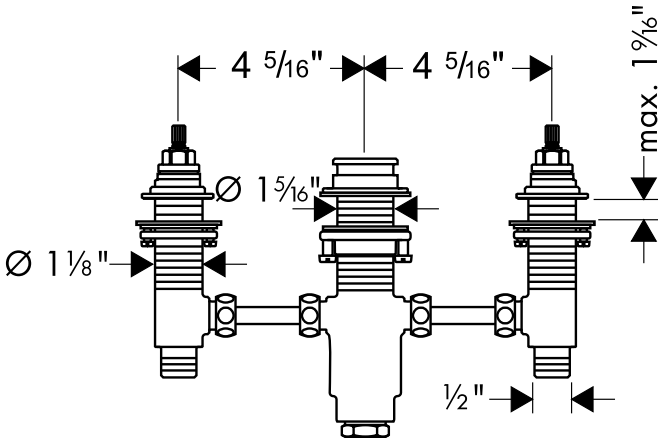

Technical Information

Recommended water pressure	45-80 psi
Max. water pressure	145 psi
Recommended hot water temp.	120° - 140° F*
Max. hot water temp	165° F*
Hole size in mounting surface	
valves	1 1/4"
spout	1 3/8"
spout retaining pin	3/16"
Max. mounting surface depth	1 1/16"
Max flow rate	10 gpm

*Please know and follow all applicable local plumbing codes when setting the temperature on the water heater.

Installation Considerations

- For best results, this unit should be installed by a licensed, professional plumber.
- Large differences in pressure between the hot and cold supplies should be balanced.
- The included connecting tubes are type "K" copper tubing. If an installation different from the one shown here is desired, the plumber may provide his own copper tubing.
- To insure proper fit of the trim, this valve must be installed after the mounting surface is finished and made watertight.
- This valve requires 1/2" hot and cold supply lines (not included)
- The hot and cold water supplies should be flushed thoroughly before installation of this rough valve. Damage to the cartridges caused by debris is not covered by the warranty.

Installation

Install the connecting tubes

Connect the valves to the spout tee using $\frac{3}{8}$ " compression fittings (included). Tighten the compression fittings wrench tight.

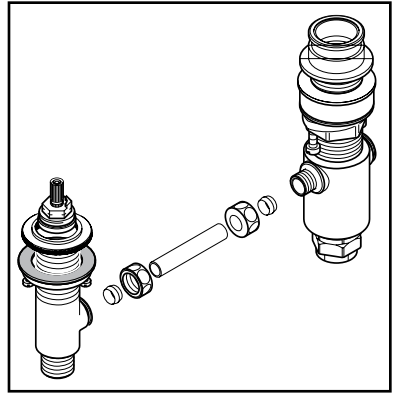

Install the rough

Remove the plaster shield, spout adapter and gasket from the spout tee.

If the mounting surface is unusually thin, leave the white plastic spacer in place. Otherwise, it may be removed and discarded.

Insert the valves and spout tee through the mounting surface.

Install the stop rings and escutcheon adapters on the valves. When installed correctly, the stop rings will stop the escutcheon adapters at the proper mounting height.

Lower the valves so that the escutcheon adapters rest on the mounting surface.

Slide the spout adapter gasket over the spout tee, aligning the hole in the gasket with the retaining pin hole on the mounting surface.

Install the spout adapter.

 **The retaining pin on the bottom of the adapter must go through the hole in the mounting surface.**

Tighten the mounting nuts and tensioning screws.

Install the plaster shields. Leave them in place until the trim is installed.

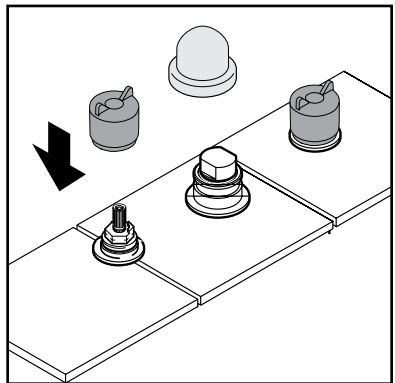
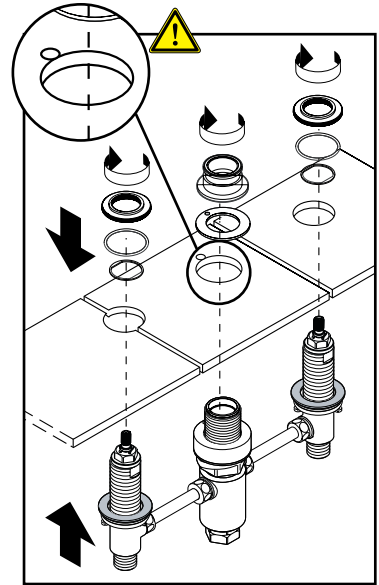

Trim, 3-Hole Roman Tub Sets

Solaris	06630XX0
Stratos	06574XX0
Metro	06651000

	Swing C	Tango C	Limbo C
Cross handle	06122XX0	06045XX0	06109XX0
Scroll handle	06121XX0	06044XX0	06108XX0
Lever handle	06120XX0	06043XX0	06107XX0

These trim kits are for use with rough 06607000. The rough must be installed, and the mounting surface complete and watertight.

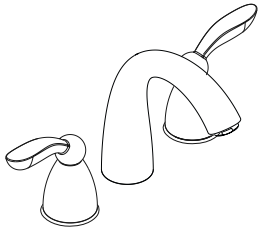

06630XX0

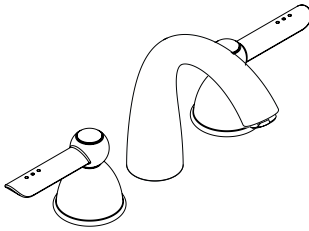

06574XX0

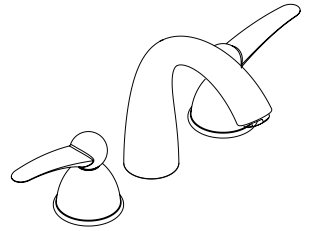

06651XX0

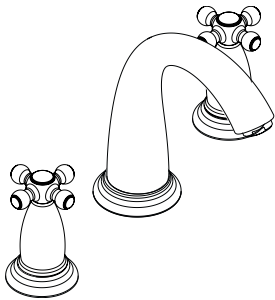

Swing C
cross handles shown

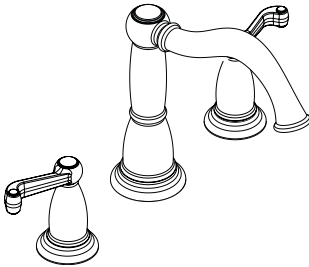

Tango C
scroll handles shown

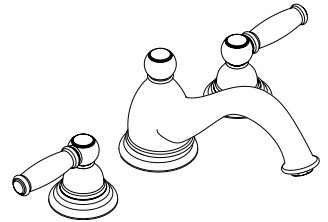

Limbo C
lever handles shown

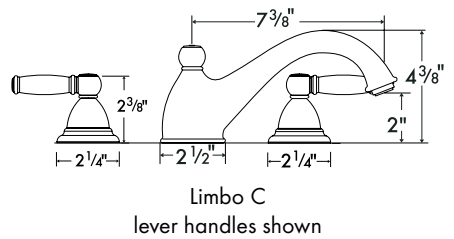
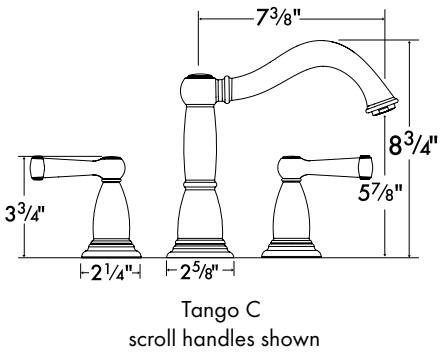
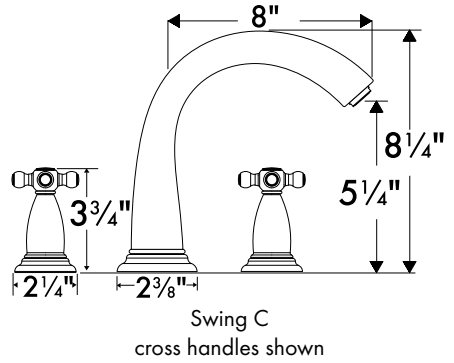
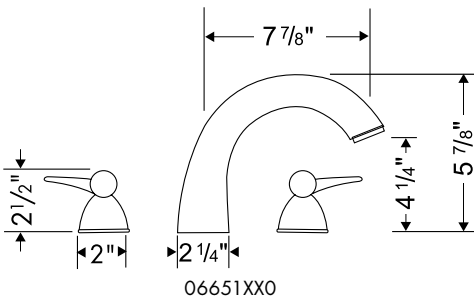
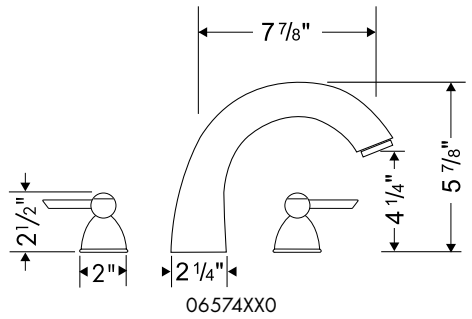
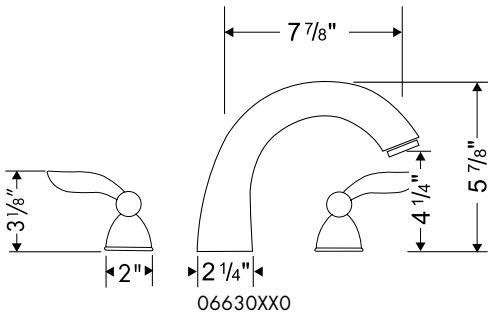

Install the Handles

Swing C, Tango C, Limbo C only: Install the deco-rings on the handles.

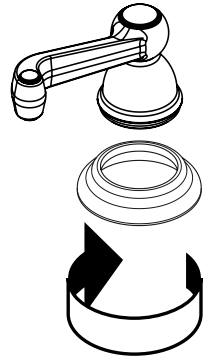

All models: Remove the plaster shields from the hot and cold valves and spout tee.

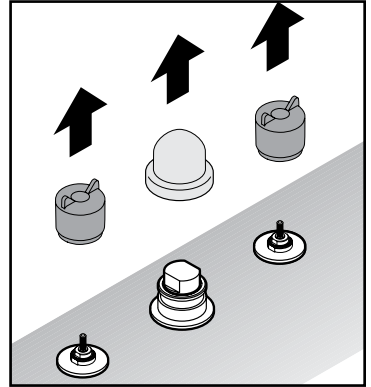

Position the handle over the stem with the lever or cross in the desired "off" position.

Hold the lever or cross with one hand.

Use the other hand to turn the bell, and screw it down over the valve.

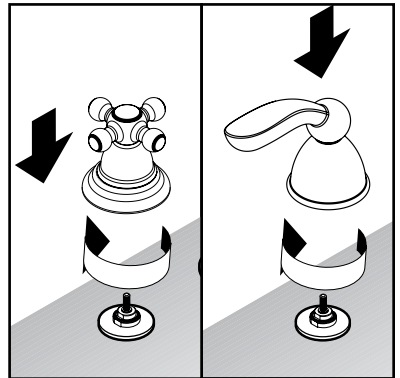

Install the spout

Remove the plug from the spout tee.

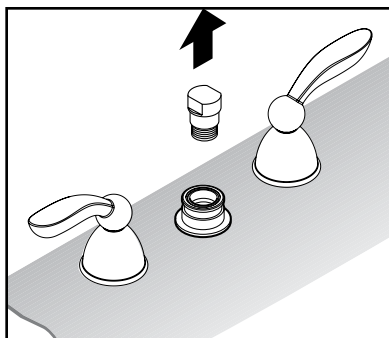

Swing C only: Install the deco-ring on the spout. Make sure that the set screw hole in the deco ring lines up with the set screw hole on the spout.

All models: Push the spout sealing ring firmly into the spout tee.

Press the spout over the spout tee. Install and tighten the set screw with the enclosed 3 mm Allen wrench.

Turn on the water and check all connections for leaks.

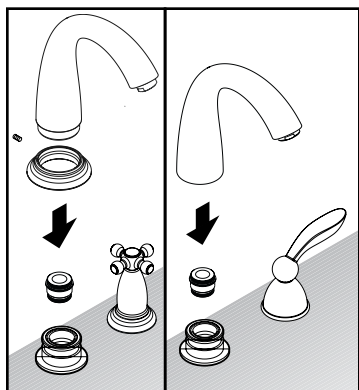

User Instructions

Turn the left handle to obtain hot water, the right handle to obtain cold water.

If the flow of water diminishes over time, remove and clean the aerator.

Replacement Parts

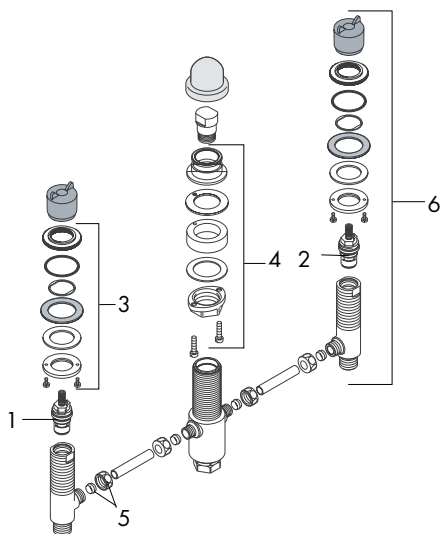

06607000

1	hot cartridge	94009000
2	cold cartridge	94008000
3	mounting kit	88511000
4	mounting kit	96080000
5	compression ftg	88513000
6	valve set	88503000

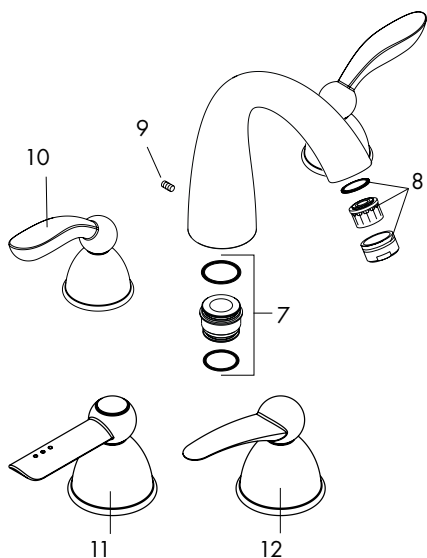

7	sealing ring	88512000
8	aerator	13956XX0
9	set screw	96029000
10	Solaris handle	88569XX0
11	Stratos handle	88571XX0
12	Metro handle	88570XX0
13	cross handle	88614XX0
14	scroll handle, cold	88613XX0
15	scroll handle, hot	88643XX0
16	lever handle	88612XX0
17	cross handle	88618XX0
18	scroll handle, hot	88616XX0
19	scroll handle, cold	88617XX0
18	lever handle	88615XX0
19	handle deco ring	88600XX0

Swing C

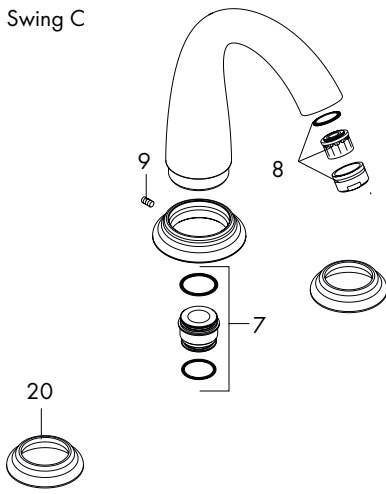

Tango C

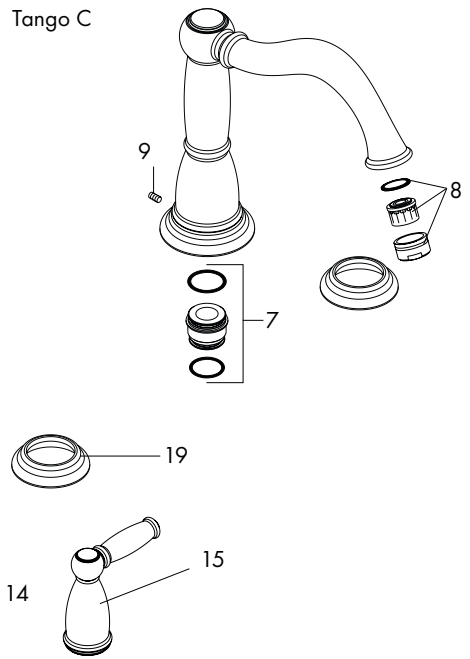

Limbo C

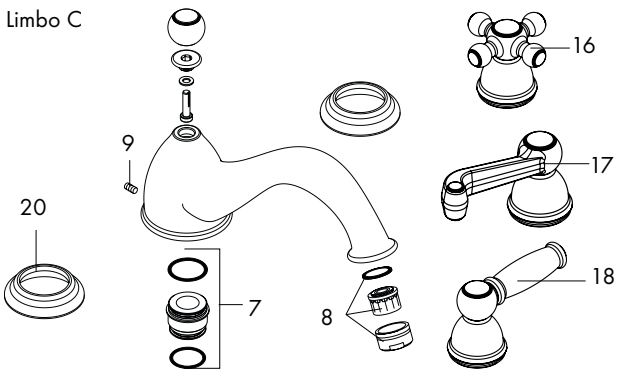

Cleaning Recommendation for Hansgrohe Products

Modern lavatory faucets, kitchen faucets, and showers consist of very different materials to comply with the needs of the market with regard to design and functionality. To avoid damage and returns, it is necessary to consider certain criteria when cleaning.

Cleaning Materials for Faucets and Showers

Acids are a necessary ingredient of cleaning materials for removing lime, however please pay attention to the following points when cleaning faucets and showers:

- Only use cleaning materials which are explicitly intended for this type of application.
- Never use cleaning materials which contain hydrochloric, formic, phosphoric, or acetic acid, as they cause considerable damage.
- Never mix one cleaning material with another.
- Never use cleaning materials or appliances with an abrasive effect, such as unsuitable cleaning powders, sponge pads, or micro fiber cloths.

Cleaning Instructions for Faucets and Showers

Please follow the cleaning material manufacturer's instructions. In addition, pay attention to the following points:

- Clean the faucets and showers as and when required
- Use the amount of cleaning product and the amount of time recommended by the manufacturer. Do not leave the cleaner on the fixture longer than necessary.
- Regular cleaning can prevent calcification.
- When using spray cleaners, spray first onto a soft cloth or sponge. Never spray directly onto the faucet as droplets can enter openings and gaps and cause damage.
- After cleaning, rinse thoroughly with clean water to remove any cleaner residue.

Important

Residues of liquid soaps, shampoos, and shower foams can also cause damage, so rinse with clean water after using.

Please note: if the surface is already damaged, the effect of cleaning materials will cause further damage.

Components with damaged surfaces must be replaced or injury could result.

Damage caused by improper treatment is not covered under the warranty.

Limited Lifetime Consumer Warranty

This product has been manufactured and tested to the highest quality standards by Hansgrohe, Inc. ("Hansgrohe"). This warranty is limited to Hansgrohe products which are purchased by a consumer in the United States after March 1, 1996, and installed in either the United States or Canada.

WHO IS COVERED BY THE WARRANTY

This warranty extends to the original consumer purchaser only. This warranty is non-transferable.

WHAT IS COVERED BY THE WARRANTY

This warranty covers only your Hansgrohe manufactured product. Hansgrohe warrants this product against defects in material or workmanship as follows: Hansgrohe will repair at no charge for parts only or, at its option, replace any product or part of the product that proves defective because of improper workmanship and/or material, under normal installation, use, service and maintenance. If Hansgrohe is unable to provide a replacement and repair is not practical or cannot be timely made, Hansgrohe may elect to refund the purchase price in exchange for the return of the product.

LENGTH OF WARRANTY

Replacement or repaired parts of products will be covered for the term of this warranty as stated in the following two sentences. If you are a consumer who purchased the product for use primarily for personal, family, or household purposes, this warranty extends for as long as you own the product and the home in which the product is originally installed. If you purchased the product for use primarily for any other purpose, including, without limitation, a commercial purpose, this warranty extends only (i) for 1 year, with respect to Hansgrohe and Commercial products, and (ii) for 5 years, with respect to AXOR products.

THIS WARRANTY DOES NOT COVER, AND HANSGROHE WILL NOT PAY FOR:

- A. Conditions, malfunctions or damage not resulting from defects in material or workmanship.
- B. Conditions, malfunctions or damage resulting from (1) normal wear and tear, improper installation, improper maintenance, misuse, abuse, negligence, accident or alteration, or (2) the use of abrasive or caustic cleaning agents or "no-rinse" cleaning products, or the use of the product in any manner contrary to the product instructions. (3) Conditions in the home such as excessive water pressure or corrosion.
- C. Labor or other expenses for the disconnection, deinstallation, or return of the product for warranty service, or for installation or reinstallation of the product (including but not limited to proper packaging and shipping costs), or for installation or reinstallation of the product.
- D. Accessories, connected materials and products, or related products not manufactured by Hansgrohe.

TO OBTAIN WARRANTY PARTS OR INFORMATION

Contact your Hansgrohe retailer, or contact Technical Service at:

Hansgrohe Inc.
1492 Bluegrass Lakes Parkway
Alpharetta GA 30004
Toll-free (800) 334-0455.

In requesting warranty service, you will need to provide

- 1. The sales receipt or other evidence of the date and place of purchase.
- 2. A description of the problem.
- 3. Delivery of the product or the defective part, postage prepaid and carefully packed and insured, to Hansgrohe Inc. 1492 Bluegrass Lakes Parkway, Alpharetta, Georgia 30004, Attention: Technical Service, if required by Hansgrohe.

When warranty service is completed, any repaired or replacement product or part will be returned to you postage prepaid.

EXCLUSIONS AND LIMITATIONS

REPAIR OR REPLACEMENT (OR, IN LIMITED CIRCUMSTANCES, REFUND OF THE PURCHASE PRICE) AS PROVIDED UNDER THIS WARRANTY IS THE EXCLUSIVE REMEDY OF THE PURCHASER. HANSGROHE NEITHER ASSUMES NOR AUTHORIZES ANY PERSON TO CREATE FOR IT ANY OBLIGATION OR LIABILITY IN CONNECTION WITH THIS PRODUCT.

HANSGROHE SHALL NOT BE LIABLE TO PURCHASER OR ANY PERSON FOR ANY INCIDENTAL, SPECIAL, OR CONSEQUENTIAL DAMAGES, ARISING OUT OF BREACH OF THIS WARRANTY OR ANY IMPLIED WARRANTY (INCLUDING MERCHANTABILITY).

Some States do not allow the exclusion or limitation of incidental or consequential damages, so the above limitation or exclusion may not apply to you. This warranty gives you specific legal rights, and you may have other rights which vary from State to State. You may be required by law to give us a reasonable opportunity to correct or cure any failure to comply before you can bring any action in court against us under the Magnuson-Moss Warranty Act.

PRODUCT INSTRUCTIONS AND QUESTIONS

Upon purchase or prior to installation, please carefully inspect your Hansgrohe product for any damage or visible defect. Prior to installing, always carefully study the enclosed instructions on the proper installation and the care and maintenance of the product. If you have questions at any time about the use, installation, or performance of your Hansgrohe product, or this warranty, please call or write to us or call us toll-free at 800 334 0455.

hansgrohe

Hansgrohe, Inc. • 1490 Bluegrass Lakes Parkway • Alpharetta, GA 30004
Tel. 770-360-9880 • Fax 770-360-9887

www.hansgrohe-usa.com