

OWNER'S MANUAL  
Model No. TMMC2 / TMMC2CAN

# Toastmaster®

**Mini Food Chopper**



# IMPORTANT SAFEGUARDS

When using electrical appliances, basic safety precautions should always be followed including the following:

1. Read all instructions.
2. To protect against risk of electrical shock do not put cord, plugs, or appliance in water or other liquid.
3. Close supervision is necessary when any appliance is used by or near children.
4. Unplug from outlet when not in use, before putting on or taking off parts, and before cleaning.
5. Avoid contacting moving parts.
6. Do not operate any appliance with a damaged cord or plug or after the appliance malfunctions, or is dropped or damaged in any manner. Contact Consumer Service for examination, repair or electrical or mechanical adjustment.
7. The use of attachments not recommended or sold by the manufacturer may cause fire, electric shock or injury.
8. Do not use outdoors.
9. Do not let cord hang over edge of table or counter.
10. Do not let cord contact hot surface, including the stove.
11. Keep hands and utensils away from moving blades while processing food to reduce the risk of severe injury to persons or damage to the Mini Food Chopper. A scraper may be used but must be used only when the Mini Food Chopper is not running.
12. Blades are sharp. Handle carefully.
13. To reduce the risk of injury, never place Blades on Base without first putting See-thru Bowl properly in place.
14. Be certain Lid is securely locked in place before operating appliance.
15. Do not attempt to defeat the Lid interlock mechanism.

## SAVE THESE INSTRUCTIONS

For Household Use Only

# ADDITIONAL IMPORTANT SAFEGUARDS

1. All users of this appliance must read and understand this Use and Care Guide before operating or cleaning this appliance.
2. The cord to this appliance should be plugged into a 120V AC electrical outlet only.
3. Do not leave this appliance unattended during use.
4. If this appliance begins to malfunction during use, immediately turn the unit OFF and unplug the cord. Do not use or attempt to repair the malfunctioning appliance.
5. If this appliance falls or accidentally becomes immersed in water, unplug it immediately. **Do not reach into the water!** Do not use this appliance after it has fallen into or becomes immersed in water.
6. To reduce the risk of injury to persons or property, never use this appliance in an unstable position.
7. Do not use this appliance for other than its intended use.
8. Use extreme care when handling the Blades. Always insert and remove Blades by using the stem of the Blades. Do not touch the Blades with your fingers. The Blades are very sharp and can cause injury if touched.
9. This Mini Food Chopper is intended for processing small quantities of food. It is not intended to prepare large quantities of food at one time.
10. Never use for extended periods of time. The Mini Food Chopper does its work in seconds.
11. Do not operate the Mini Food Chopper without food contents in See-thru Bowl.
12. Do not use if the See-thru Bowl is cracked or chipped.

## Polarized Plug

---

This appliance has a polarized plug (one blade is wider than the other). To reduce the risk of electric shock, this plug is intended to fit into a polarized outlet only one way. If the plug does not fit fully in the outlet, reverse the plug. If it still does not fit, contact a qualified electrician. Do not attempt to modify the plug in any way.

## Short Cord Instructions

---

A short power-supply cord is provided to reduce the risk resulting from becoming entangled in or tripping over a longer cord.

Do not use an extension cord with this product.

## Electric Power

---

If the electrical circuit is overloaded with other appliances, your appliance may not operate properly. It should be operated on a separate electrical circuit from other appliances.

## Plasticizer Warning

---

**CAUTION:** To prevent Plasticizers from migrating from the finish of the countertop or tabletop or other furniture, place **NON-PLASTIC** coasters or placemats between the appliance and the finish of the countertop or tabletop.

**Failure to do so may cause the finish to darken, permanent blemishes may occur or stains can appear.**

# Getting to Know Your Toastmaster® Mini Food Chopper

---

Your product may vary slightly from illustration.

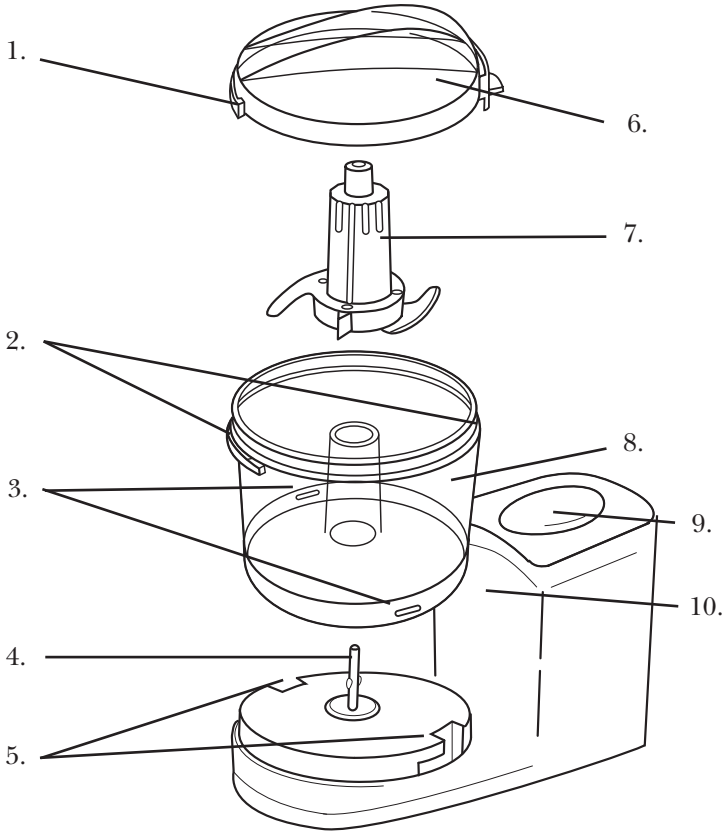

1. Lid Locking Tab
2. Bowl Lid Tabs
3. Bowl Tabs
4. Drive Shaft
5. Bowl Notches
6. Lid (P/N 71263)

7. Stainless Steel Chopping/  
Mincing Blades (P/N 71264)
8. See-thru Bowl (P/N 71265)
9. Pulse/On Button
10. Lid Locking Slot

# Introduction

---

The See-thru Bowl holds up to 1½ cups of food. Do not overfill. Cut food into uniform ½ inch pieces before processing. Some foods may require processing in smaller quantities. Some foods that may be processed in your Mini Food Chopper are: bread, dry cereal, hard cheese such as Romano & Parmesan, crackers, cookies, chocolate baking bars, hard boiled eggs, fresh herbs, soft nuts such as pecans and walnuts, fruits and vegetables such as apples, pears, celery, onion, carrots, garlic, ginger, pickles and radishes.

## Before Using for the First Time

---

- Remove all packaging materials before using.
- Before using, wash Lid, Blades and See-thru Bowl in warm soapy water; rinse and dry thoroughly, see CLEANING INSTRUCTIONS.

**CAUTION: BLADES ARE SHARP, HANDLE WITH CARE.**

**CAUTION: DO NOT IMMERSE MOTOR BASE IN WATER OR OTHER LIQUIDS.**

## Mini Food Chopper Operation

---

1. Place the Mini Food Chopper on a stable, dry and level surface.
2. Place See-thru Bowl without Lid and Blades on Base. Line up Bowl Tabs with Bowl Notches in Base and turn clockwise to lock into position.
3. Lower Blades over Drive Shaft in See-thru Bowl, rotating if necessary to drop into place.
4. Cut food into ½ inch uniform pieces and place up to 1½ cups into See-thru Bowl.
5. Place Lid on the See-thru Bowl. Turn Lid until Lid Locking Tab slides into Lid Locking Slot. The raised arrows should be aligned and the Lid will click into place.

*Note: The Mini Food Chopper will not operate unless the Lid Locking Tab is correctly inserted into the Lid Locking Slot.*

6. Plug into a 120V AC outlet.
7. To start, press the Pulse/On Button for 3-5 seconds and then release; the motor will stop. Repeat pulse for a finer consistency. If Mini Food Chopper does not start, repeat steps 2-7.

## Chopper Operation (Cont.)

---

8. When finished chopping, unplug the unit and allow Blades to stop rotating before disassembling.
9. Turn the Lid counterclockwise and remove. Carefully grasp stem of Blades and lift out of See-thru Bowl. Turn See-thru Bowl counterclockwise to release and lift off Base.
10. Remove chopped food from See-thru Bowl.

## Helpful Hints

---

- Be careful not to over-process. Most foods require only 3-10 seconds.
- Process up to 1½ cups of food at a time. If larger quantities are desired, process in several small batches.
- If food is not chopped into even-sized pieces, remove some of it from the See-thru Bowl and process smaller quantities at a time.
- Do not attempt to process extremely hard food which is difficult to cut with a kitchen knife.
- Remove bones, pits, and hard shells before processing to avoid damage to the unit.
- This unit is not designed for processing liquids or foods with a high liquid content.

## User Maintenance Instructions

---

This appliance requires little maintenance. It contains no user serviceable parts. Do not try to repair it yourself. Any servicing requiring disassembly must be performed by a qualified appliance repair technician.

# Cleaning Instructions

---

**CAUTION: Blades are sharp. Handle carefully.**

**CAUTION: Never place base of appliance in water or other liquids.**

1. Unplug and allow Blades to stop rotating before disassembling.
2. Wash all removable parts in warm soapy water; rinse and dry thoroughly. Removable parts may also be placed on the top shelf of your dishwasher.
3. Clean exterior or Motor Base with a soft damp cloth and dry.

# Storing Instructions

---

1. Unplug and clean unit.
2. Store unit in its box or in a clean, dry place. Never store unit while it is still plugged in. Never wrap cord tightly around the appliance. Do not put any stress on the cord where it enters the unit, as it could cause the cord to fray and break.



## LIMITED ONE-YEAR WARRANTY

**Warranty Coverage:** This product is warranted to be free from defects in materials or workmanship for a period of one (1) year from the original purchase date. This product warranty is extended only to the original consumer purchaser of the product and is not transferable. For a period of one (1) year from the date of original purchase of the product, our Repair Center will, at its option, either (1) repair the product or (2) replace the product with a reconditioned comparable model. These remedies are the purchaser's exclusive remedies under this warranty.

**Warranty Service:** To obtain warranty service, you must call our warranty service number at 1-800-233-9054 for return instructions on how to deliver the product, in either the original packaging or packaging affording an equal degree of protection to the Repair Center specified below. You must enclose a copy of your sales receipt or other proof of purchase to demonstrate eligibility for warranty coverage.

**To return the appliance, ship to:**

ATTN: Repair Center  
708 South Missouri Street  
Macon, MO 63552 USA

**To contact us, please write to, call, or email:**

Consumer Relations Department  
PO Box 7366  
Columbia, MO 65205-7366 USA  
1-800-233-9054  
E-mail: [consumer\\_relations@toastmaster.com](mailto:consumer_relations@toastmaster.com)

**What Is Not Covered:** This warranty does not cover damage resulting from misuse, accident, commercial use, improper service or any other damage caused by anything other than defects in material or workmanship during ordinary consumer use. This warranty is invalid if the serial number has been altered or removed from the product. This warranty is valid only in the United States and Canada.

**LIMITATION ON DAMAGES:** THERE SHALL BE NO LIABILITY FOR ANY INCIDENTAL OR CONSEQUENTIAL DAMAGES FOR BREACH OF ANY EXPRESS OR IMPLIED WARRANTY OR CONDITION ON THIS PRODUCT.

**DURATION OF IMPLIED WARRANTIES:** EXCEPT TO THE EXTENT PROHIBITED BY APPLICABLE LAW, ALL IMPLIED WARRANTIES AND CONDITIONS, INCLUDING, WITHOUT LIMITATION, IMPLIED WARRANTIES AND CONDITIONS OF MERCHANTABILITY AND FITNESS FOR A PARTICULAR PURPOSE OR USE ON THIS PRODUCT ARE LIMITED IN DURATION TO THE DURATION OF THIS WARRANTY.

Some jurisdictions do not allow the exclusion or limitation of incidental or consequential damages, or allow limitations on how long an implied warranty lasts, so the above limitations or exclusions may not apply to you. This warranty gives you specific legal rights and you may have other rights under the laws of your jurisdiction.

For more information on our products, visit our website: [www.maxim-toastmaster.com](http://www.maxim-toastmaster.com).