

Electrolux

DITO

K45 Vertical Cutter-Mixer

ITEM # _____

MODEL # _____

PROJECT NAME # _____

SIS # _____

AIA # _____

Electrolux
DITO



Main features

- Power: 1-1/4HP for two speed model, and 1-1/3 HP for variable speed model.
- 1800/3600 rpm for two speed model, and 300-3600 rpm for variable speed model.
- 900 watts for two speed model, and 1 kW for variable speed model.
- Red OFF, green ON, and PULSE buttons.
- Compact design.
- Belt drive.
- All stainless steel bowl.
- Magnetic safety system and motor brake. Prevents machine from running when bowl lid swings away from magnetic switch or is open.
- Delivered with:
 - 4.7 qt. stainless steel bowl with microtooth edge "S" blade included.
 - Complete selection of accessories available.
 - Dimensions: (HxLxW): 18.5" x 16.3" x 10".
 - Approx. shipping weight—49 lbs.
- NEMA L15-20P for two speed model, and NEMA 6-20P for variable speed model.
- 2 year parts warranty, 1 year labor.

Included Accessories:

- Microtooth Blade Rotor - 4.7 qt. VCM (PNC 653580)
- Lid + Bowl Scraper for 4.7 qt. VCM (PNC 653588)
- 4.7 qt. Stainless Steel Bowl (PNC 653589)

Optional Accessories:

- Smooth Blade Rotor - 4.7 qt. VCM (PNC 653579)
- Microtooth Blade Rotor - 4.7 qt. VCM (PNC 653580)
- Lid + Bowl Scraper for 4.7 qt. VCM (PNC 653588)
- 4.7 qt. Stainless Steel Bowl (PNC 653589)
- Kit for vegetable slicer conversion for the variable speed VCM (PNC 653594)



Approval: _____

Electrolux Professional, Inc.

www.electroluxusa.com/professional

3225 SW 42nd Street, Fort Lauderdale, Florida, 33312 • Telephone Number: 866-449-4200 • Fax Number: 954-327-6789

K45 Vertical Cutter-Mixer

Front View

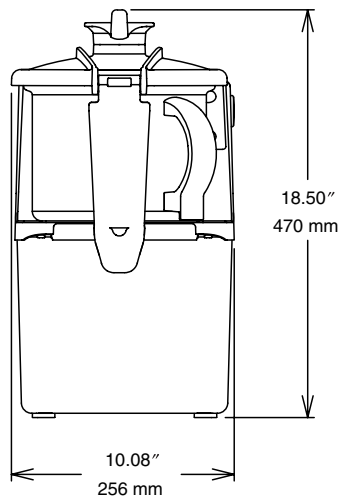

Side View

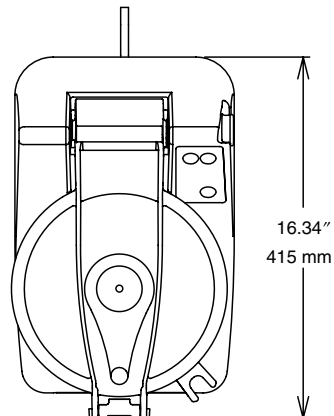

EC = Electrical connection

Top View

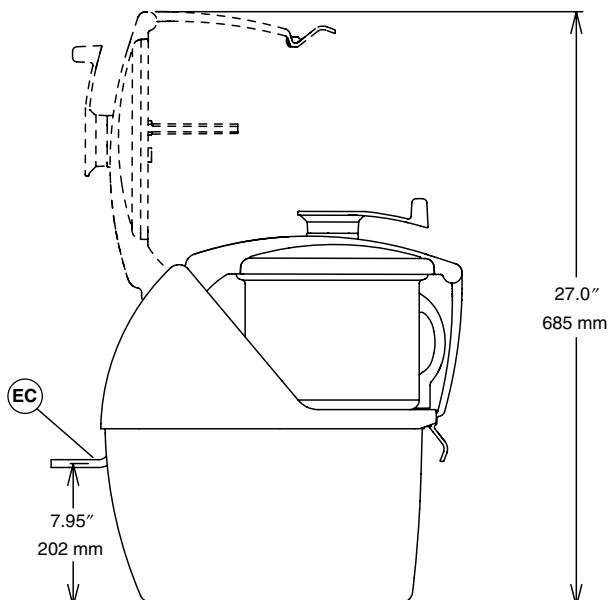

Electric

Supply voltage:

603359 (K452VU) 208-240 V/3p/60Hz – 3.8A

603362 (K45VVU) 120 V/1p/50/60Hz – 5A

Key Information

Uses of Food Processor

MEAT

Rough mincing

- Pates
- Small sausages
- Large sausages
- Minced meat

Shellfish

Fine mincing

Stuffing

Mousses

PASTRY

Shortcrust

Cold water paste

Flan

POWDER

Almonds

Hazelnuts

FRUITS AND VEGETABLES

Purees

Mousses

Syrups

CHOPPING

Parsley

Onions