

Item
Model
ProjectName



603287

TBX120

The TBX 120 floor-standing grinder with removable mixer tube is fitted with a turbine effect mixing head, which significantly improves the grinding fineness and throughput. The turbo liquidisers are used to mix, liquidise, reduce and emulsify vegetable and fish soups, fruit and vegetable purées, liquid pastries and sauces. These preparations can be carried out directly in the cooking containers or in suitable liquid containers.

FEATURES

- The turbo liquidisers are designed to withstand intensive use in large catering, central kitchens and the food preparation industries.
- Stainless steel is used to withstand the humid atmosphere of the various production environments.
- Height adjustable on installing.
- All models are mounted onto a stainless steel trolley with castors.
- All models can be adapted to all shapes of recipients: cylindrical, rectangular, hemispherical.
- All models have a turbine that gives an accelerated flow of the liquid over the impeller giving greater throughput and finer grinding.

Turbo Liquidisers



DITO**Electrolux**

- Safety device in non-working position and protective ring for the grinding head.
- Grinding head can be removed without tools for easier cleaning.

- Touch control panel allows the entire machine to be cleaned with a jet of water (IP66 water protection).

Specifications

MODEL	TBX120F 603287	TBX120FP 603288
External dimensions - mm		
width	640	640
depth	1625	1625
height	1330	1330
Electrical power - kW	0.9	0.9
Net weight - kg.	76	76
Supply voltage	230/400 V, 3, 50	230/400 V, 3, 50/60

Included accessories

CODE	DESCRIPTION	TBX120F 603287	TBX120FP 603288
653485	S/S TUBE FOR PUREES FOR TURBO LIQUIDISER		1
653519	S/S TUBE FOR SOUPS FOR TURBO LIQUIDISER	1	

Optional accessories

CODE	DESCRIPTION	TBX120F 603287	TBX120FP 603288
653520	BRAISING PAN KIT EJECTOR F. TURBO LIQUID.	✓	✓
653507	FISH SOUP GRID FOR TURBO LIQUIDISERS	✓	✓
653502	PUREE KIT FOR TURBO LIQUIDISERS	✓	✓
653485	S/S TUBE FOR PUREES FOR TURBO LIQUIDISER	✓	✓
653519	S/S TUBE FOR SOUPS FOR TURBO LIQUIDISER	✓	✓



DITO

Electrolux

Installation drawings

603287, 603288

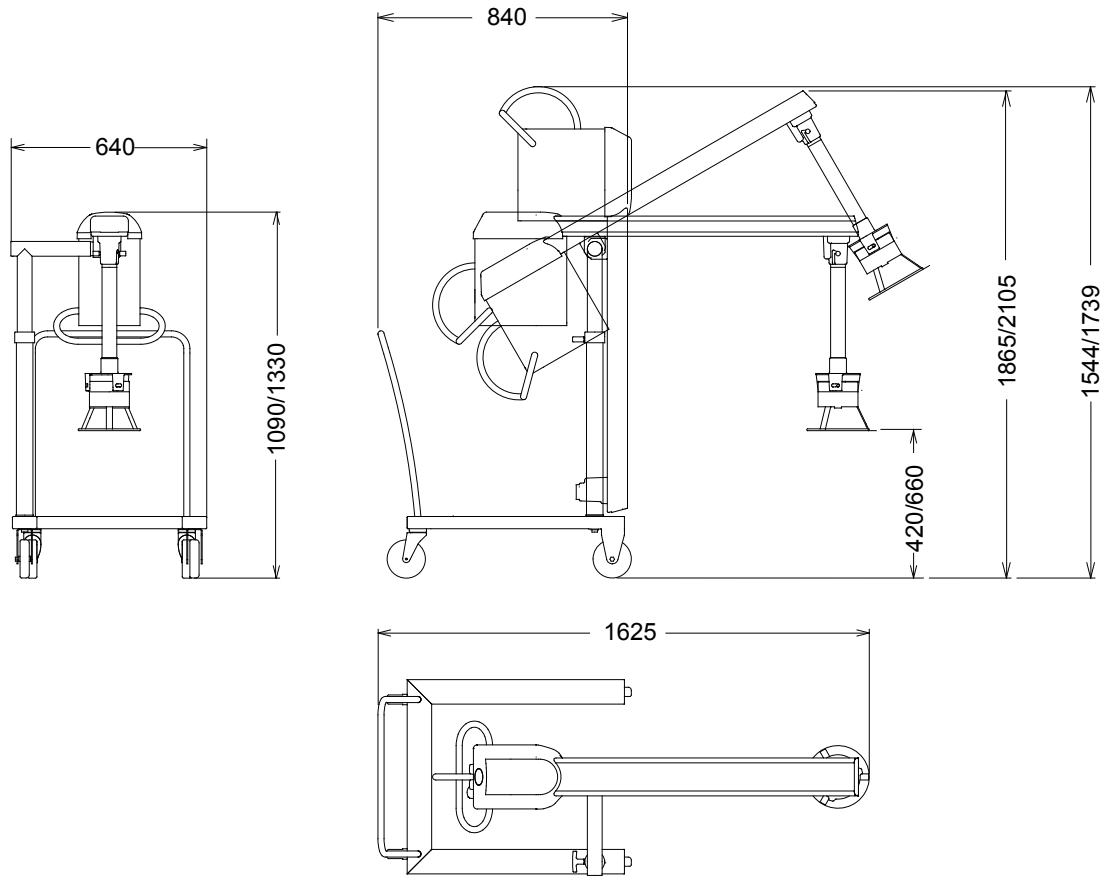

MODEL	TBX120F 603287	TBX120FP 603288
I - Electrical connection	230/400 V, 3, 50	230/400 V, 3, 50/60



Turbo Liquidisers

The manufacturer reserves the right to modify and make improvements to the products without giving prior warning. Dimensions, illustrations, technical data, weights, etc. are given as an indication only.



www.dito-electrolux.com

