

**PC100 Terminal**

# Installation & User's Guide

**PayClock, Lathem and the Lathem logo** are registered trademarks of Lathem Time Corporation. Other product names mentioned in this manual may be trademarks of their respective companies and are hereby acknowledged.

**Warning:** Changes or modifications to this unit not expressly approved by the party responsible for compliance could void the user's authority to operate the equipment.

**NOTICE: This equipment has been tested and found to comply with the limits for a Class A digital device, pursuant to Part 15 of the FCC Rules.** These limits are designed to provide reasonable protection against harmful interference when the equipment is operated in a commercial environment. This equipment generates, uses, and can radiate radio frequency energy and, if not installed and used in accordance with the instructional manual, may cause harmful interference to radio communications. Operation of this equipment in a residential area is likely to cause harmful interference in which case the user will be required to correct the interference at his or her own expense.

*Shielded cables must be used with this unit to ensure compliance with the Class A FCC limits*

## **Limited One-Year Limited Warranty**

Lathem warrants the hardware products described in this guide against defects in material and workmanship for a period of **one year** from date of original purchase from Lathem or from an authorized Lathem reseller. The conditions of this warranty and the extent of the responsibility of Lathem Time Corporation (“Lathem”) under this warranty are listed below.

1. This warranty will become void when service performed by anyone other than an approved Lathem warranty service dealer results in damage to the product.
2. This warranty does not apply to any product which has been subject to abuse, neglect, or accident, or which has had the serial number altered or removed, or which has been connected, installed, adjusted, or repaired other than in accordance with instructions furnished by Lathem.
3. This warranty does not cover dealer labor cost for removing and reinstalling the machine for repair, or any expendable parts that are readily replaced due to normal use.
4. The sole responsibility of Lathem under this warranty shall be limited to repair of this product, or replacement thereof, at the sole discretion of Lathem.
5. If it becomes necessary to send the product or any defective part to Lathem or any authorized service dealer, the product must be shipped in its original carton or equivalent, fully insured with shipping charges prepaid. Lathem will not assume any responsibility for any loss or damage incurred in shipping.
6. **WARRANTY DISCLAIMER AND LIMITATION OF LIABILITY:** Except only the limited express warranty set forth above, the products are sold with no expressed or implied warranties of any kind, and the implied warranties of merchantability and fitness for a particular purpose are hereby expressly disclaimed. No warranties are given with respect to products purchased other than from Lathem or an authorized Lathem reseller and any such products are purchased "as is, with all faults." In no event will Lathem be liable for any direct, indirect, special, incidental or consequential damages arising out of or in connection with the delivery, use or inability to use, or performance of this product. In the event any limited remedy given herein shall be deemed to have failed of its essential purpose, Lathem's maximum liability shall be to refund the purchase price upon return of the product.
7. Proof of date of purchase from Lathem or an authorized Lathem reseller is required for warranty service on this product.
8. This Warranty grants specific legal rights. Additional legal rights, which may vary by locale, may also apply.
9. Should any difficulties arise with the performance of this product during warranty, or with any Lathem authorized service centers, contact Lathem Time at the address below.

Lathem Time  
200 Selig Drive, SW, Atlanta, GA 30336  
**404-691-0405**

[www.lathem.com](http://www.lathem.com)

Copyright © 2003 Lathem Time Corporation. All rights reserved.

Document number: USG0038C

08-04-2006



# Contents

<b>Welcome</b>	<b>1</b>
<b>Mounting the PC100</b>	<b>2</b>
<b>Connecting to the Computer</b>	<b>4</b>
Connecting the PayClock via RS-232 .....	4
Connecting Terminals via RS-485 .....	4
Connecting Terminals via RS-485 (Star Configuration) .....	5
Connecting Terminals via RS-485 (Multi-Drop Configuration) .....	6
<b>Using the PC100</b>	<b>7</b>
Special Badges .....	7
<i>Badge #251 – View Clock Status</i> .....	7
<i>Badge #253 – Set Baud Rate</i> .....	8
<i>Badge #254 – Setup Terminal ID</i> .....	8
Specifications .....	9
<b>Cable Wiring Diagrams</b>	<b>10</b>
RS-232 (Computer to PC100) .....	10
RS-485 Multi-Drop .....	11
Junction Box to Terminal .....	12
<b>Troubleshooting</b>	<b>13</b>
PC100 .....	13



### CHAPTER 1

# Welcome

Reliability, functionality and ease of use are trademarks of the PayClock terminal. With the PC100 terminal, employees use their plastic ID badges to punch in and out – it's that simple. Using Lathem software and your computer, the PayClock terminal is the perfect solution for businesses that want to track employee time and automate payroll.

*The PC100 terminal package includes the following:*

- PC100 Terminal
- AC Wall Adapter – 115 VAC 60 HZ
- Mounting Bracket
- 3 Mounting Screws and Anchors
- 2 Keys

## CHAPTER 2

# Mounting the PC100

Check your package contents to make sure everything is accounted for before starting. Decide where to mount your clock. Keep in mind that the AC adapter plugs into a wall outlet.

To mount the clock, you need the following items:

Drill with a 5/16" bit  
Hammer  
Phillips head screwdriver  
Pencil

### 1. Screw the mounting bracket to the wall

- » Hold the bracket against the wall so the top (arrow pointing Up) is 54 inches from the floor
- » Mark the 3 holes with a pencil
- » Remove the bracket and drill a 5/16-inch hole at each mark
- » Insert an anchor into each hole, tapping it with a hammer until it is flush against the wall
- » Align the mounting bracket back on the wall
- » Insert each screw through the bracket into the anchors, and tighten securely

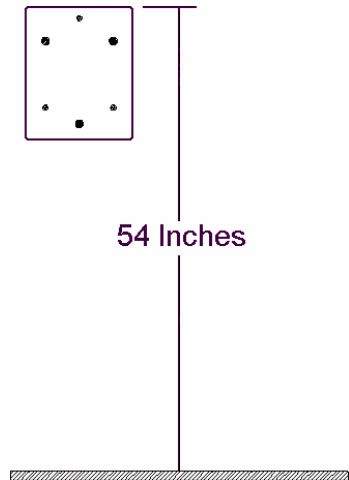



### **2. Place the clock onto the mounting bracket**

- » Turn your key counter-clockwise in the lock at the clock's right-middle section to unlock
- » Align the keyholes on the back of the clock with the studs on the mounting bracket
- » Slide the clock down onto the bracket
- » Turn the key clockwise to lock the clock onto the bracket
- » Remove the key

## CHAPTER 3

# Connecting to the Computer

After mounting your PayClock on the wall, you need to connect it to your computer. You can connect the PayClock terminal to the computer using an RS-232 cable or RS-485 cable. Choose the setup that best suits your needs.

### ***Connecting the PayClock via RS-232***

1. Turn the PayClock so its back faces you
2. Plug the power cord (AC adapter) into the PayClock, keeping the cord slack
3. Plug the other end of the power cord into a wall outlet
4. Connect the jack end of the serial cable to the PC100
5. Connect the other end of the serial cable to an open COM port on your computer. All serial ports are raised pin (male) connectors

### ***Connecting Terminals via RS-485***

When selecting your installation method, the type of wire that will be used is important. Silver Satin (Modular) cable can be used for short distances less than 100' to achieve communications. Category-3 or Category-5 cable with twisted pairs should be used for distances greater than 100', in installations using J-Kits or in areas where the cable may run near a device that transmits an RF frequency. *Do not use J-Kits with modular wire*

*For details, see the Cable Wiring Diagrams appendix.*

The Swift-485+ allows you to connect PayClock terminals to the modular ports and to the screw terminal blocks. You can use either of the screw terminal blocks to connect the PC2000, PC100-R or PC3500 terminals. The PC100 / PC2000 modular port is set up to use with the PC2000 and PC100-R terminals. The PC2500 modular port is set up to use with the PC400 terminals (not currently available). The RS232 connection to the PC is made simple using a stereo type plug in jack.

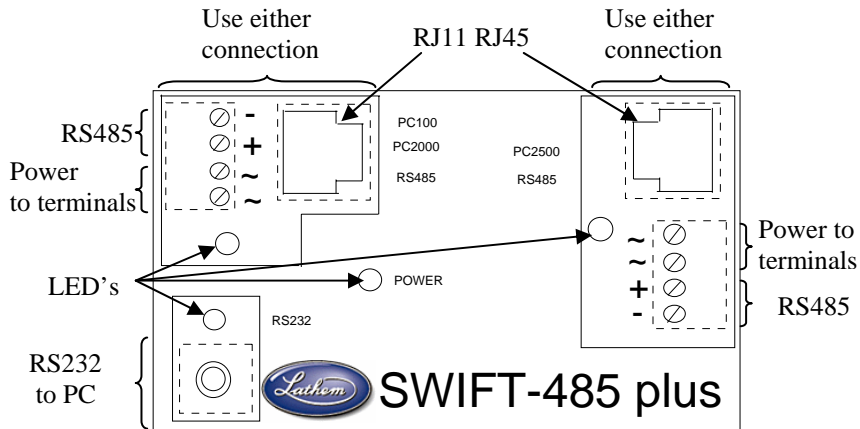

## Connecting Terminals via RS-485 (Star Configuration)

A star network connects up to 31 terminals or sync time devices to the computer. You can wire the terminals directly to the SWIFT-485+ or use J-kits (junction boxes). Terminals can be located up to 4000 feet from the computer

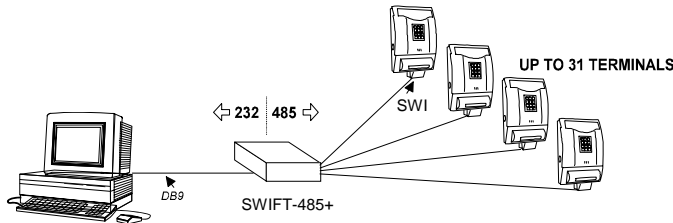

1. Run Category 3 (minimum) cable from the SWIFT-485+ to a terminal or J-kit. If you connect directly to a terminal, use an RJ-45 or RJ-11 connector on the end that plugs into the terminal
2. Connect the AC power cord adapter to each terminal and plug the cord into a wall outlet
3. Repeat these steps for each terminal in the network

4. See the Cable Wiring Diagrams for detailed connection points

### Connecting Terminals via RS-485 (Multi-Drop Configuration)

A multi-drop network connects up to 31 terminals or sync time devices to the computer. You wire the terminals to junction boxes running in a single line starting from the SWIFT-485+. Terminals can be located up to 4000 feet from the computer

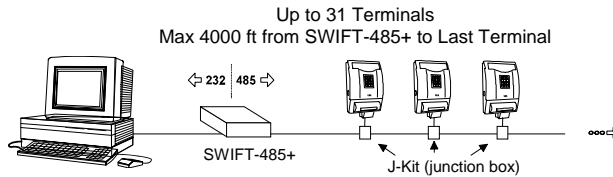

1. Run Category 3 (minimum) cable from the SWIFT-485+ to the first J-Kit (junction box)
2. Use a cable (up to 4 feet long) with an RJ-11 connector on both ends, and plug one end into the J-Kit (junction box)
3. Plug the other RJ-11 connector to a terminal
4. Connect the power cord (AC adapter) to the terminal and plug the cord into a wall outlet
5. For the next terminal, run cable from the previous J-Kit (junction box) to the next J-Kit (junction box) and repeat steps 2, 3 & 4
6. See the Cable Wiring Diagrams for detailed connection points

*For more details or how to supply AC power to the PC100-R from the SWIFT-485+, see the SWIFT-485+ User's Guide.*

## CHAPTER 4

# Using the PC100

The base model PC100 clock allows only an RS-232 connection. The PC100-R model allows RS-232 or RS-485 connections; RS-485 connections require the Terminal Manager software add-on.

The PC100 has a magnetic stripe badge reader. The magnetic stripe should be on the left side of the badge when swiping. To swipe the badge, insert it at the top of the reader, and then pull it down with a continuous and smooth motion.

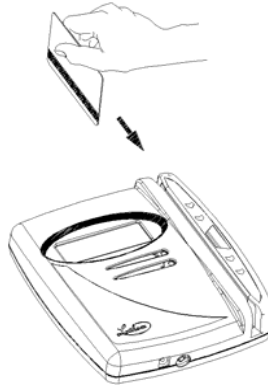

## Special Badges

Three supervisor badges are available for your PC100. These badges perform certain tasks at the clock.

### ***Badge #251 – View Clock Status***

This badge displays a clock status report. The status report shows the current clock setup:

VER 1.05	CLK READY
ID# 049	BAUD 9600
MEM 10%	TIME 12HR
	DST ON

- ◆ PC100 version number
- ◆ Terminal ID# (ID=49)
- ◆ Percent full memory  
(each time you poll the clock, this resets to 0%)
- ◆ Clock ready status (READY/LOAD LIST)
- ◆ Baud Rate
- ◆ 12-Hour or 24-Hour time display format
- ◆ Daylight Savings Time (DST) ON/OFF

After a few seconds, the display returns to normal.

### ***Badge #253 – Set Baud Rate***

Swipe this badge to change the baud rate – the default is 9600. You may need to reduce the baud rate if you have problems communicating with the clock. These problems can result from a noisy environment or a long serial cable (usually more than 50 feet).

ENTER BAUD 1ST DIGIT

1200 2400 4800 9600

To change the baud rate, swipe the Set Baud Rate badge, then when prompted, swipe employee badge #1, 2, 4 or 9 to indicate 1200, 2400, 4800 or 9600 baud.

---

NOTE: RS-485 communications do not support 1200 baud

---

### ***Badge #254 – Setup Terminal ID***

Swipe this badge to change the clock ID – the default ID is 49. When prompted, swipe an employee badge that matches your desired ID. If you have more than one clock, make sure each one has a unique ID number.

### Specifications

Casing: 6.375"W x 7.375"H x 1.5"D flame-retardant ABS plastic. 19 oz.  
Includes key lock and wall mounting bracket

Power: 6VDC/ 300 mA wall-mount power supply. UL approved

Display: 4 lines x 20 characters liquid crystal with large block digits

Swipe Status: "Beeper" signals good or bad badge reading and low memory.  
Green and red LED's show good or bad badge swipes

Badge

Reader: Mag-Stripe Track 2 reads standard "credit card" format

Badges: Accepts badges #1-250. Badge metallic stripes are even-parity

Memory: Stores about 1,500 registrations. Protected by internal 10-year lithium battery.

This product's lithium battery contains Perchlorate Material – special handling may apply. Please go to web site [www.dtsc.ca.gov/hazardouswaste/perchlorate](http://www.dtsc.ca.gov/hazardouswaste/perchlorate) for information about proper methods of disposal in California.

Ports: RS-232 cable at speeds of 1200, 2400, 4800 and 9600 baud

For PC100-R: RS-485 Cat. 3 or Cat. 5 cable (suggested) at speeds of 2400, 4800 and 9600 baud. Up to 4000 feet

Certifications: UL; C-UL; FCC Part-15 Class-B; Canada ICES-003 Class-B; CE-CENELEC EN55022; CENELEC EN55024

APPENDIX A

# Cable Wiring Diagrams

## RS-232 (Computer to PC100)

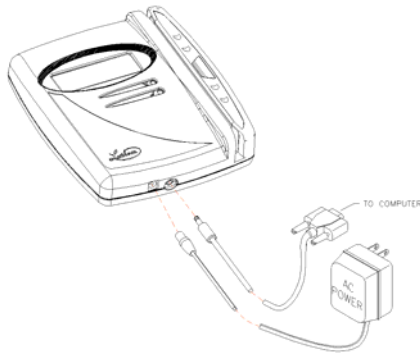



## RS-485 Multi-Drop

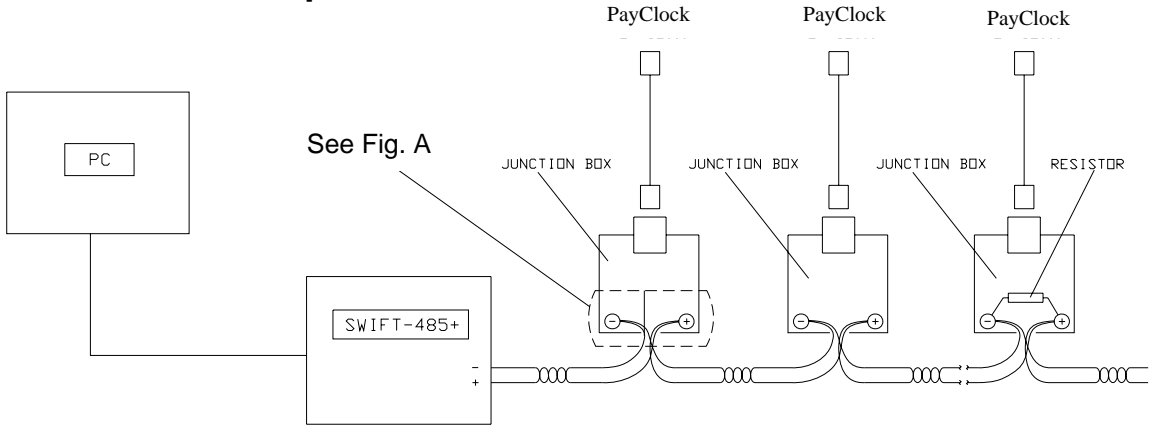

Be sure to maintain polarity through out the chain

### Fig. A – Junction box wiring connect points

Some junction boxes have only six connect points instead of eight

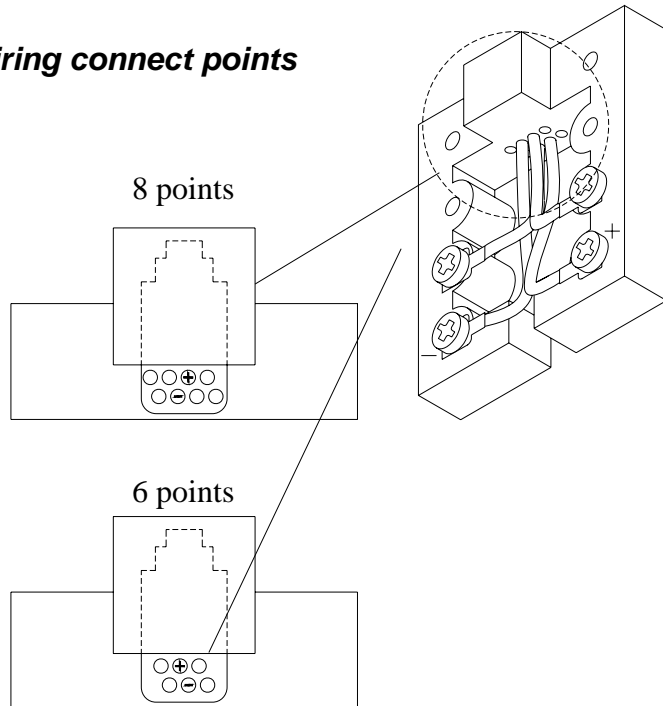

## Junction Box to Terminal

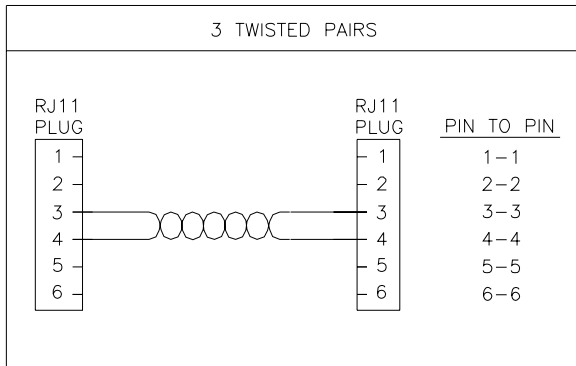
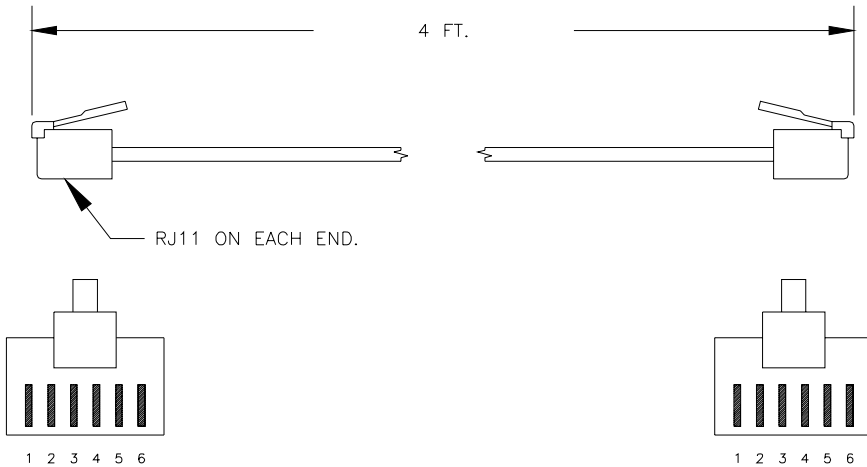

PC 2000 RJ-11	JUNCTION RJ-11
1 NOT USED	1
2 AC POWER	2 FOR PC100-R ONLY
3 D+	3
4 D-	4
5 AC POWER	5 FOR PC100-R ONLY
6 NOT USED	6

APPENDIX B

# Troubleshooting

## PC100

<i>Description</i>	<i>Solution</i>
When I swipe a badge, it does not record and the clock does not signal any errors	Make sure you swiped the badge correctly. See the section on Using the PC100  <i>Or</i> This badge may have been exposed to something magnetic. Replace this badge with a new one



## INDEX

<b>B</b>		<b>S</b>	
Badges.....	7	Screws.....	<i>See Mounting</i>
Baud Rate.....	8	Special Badges.....	7
Bracket.....	<i>See Mounting</i>	Specifications	
Bus Configuration.....	6	PC100.....	9
<b>C</b>		Star Configuration.....	5
Cable.....	4	Supervisor Badges.....	7
<b>J</b>		Sync Time Devices.....	9
Junction Box.....	12	<b>T</b>	
<b>M</b>		Terminal Connections.....	4
Modem.....	4	Terminal ID.....	8
Mounting.....	1	T-Junction Box.....	12
PC100.....	2	Troubleshooting	
Multi-Drop Configuration.....	6	PC100.....	13
<b>P</b>		<b>V</b>	
PC100.....	1, 7, 9	View Clock Status.....	7
PC2000.....	4	<b>W</b>	
Punch the Clock.....	1	Wiring Diagrams.....	10
<b>R</b>			
RS-232.....	4, 10		
RS-485.....	4		