

MX MARINE

***MX535 UAIS Shipborne Class A
Transponder System***

***Technical &
Installation
Manual***



Leica



MX535 UAIS Ship Borne Class A Transponder Unit

Technical & Installation Manual

WARNING:

THIS EQUIPMENT COMPLIES WITH **PART 80** OF THE **FCC** RULES. ANY CHANGES OR MODIFICATIONS NOT EXPRESSLY APPROVED BY THE MANUFACTURER COULD VOID THE USER'S AUTHORITY TO OPERATE THE EQUIPMENT.

IMPORTANT NOTICE

THE MX535 SYSTEM IS AN AID TO NAVIGATION. UNDER NO CIRCUMSTANCES SHOULD IT BE USED IN LIEU OF AUTHORIZED GOVERNMENT CHARTS. ITS ACCURACY CAN BE AFFECTED BY MANY FACTORS SUCH AS EQUIPMENT DEFECTS, ENVIRONMENTAL CONDITIONS, OR IMPROPER OPERATION. THE USER IS RESPONSIBLE FOR SAFE NAVIGATION OF THE VESSEL. THIS INCLUDES CONSULTING AUTHORIZED GOVERNMENT CHARTS AND EXERCISING COMMON PRUDENCE AND NAVIGATIONAL JUDGEMENT AT ALL TIMES.

©MX-Marine

January, 2005

By: TCD

This document is the property of MX-Marine.

It must not be reproduced or otherwise made available to any third party without our permission in writing. Alterations due to technical progress are reserved.

**MX Marine (USA)
23868 Hawthorne Blvd., Suite 201
Torrance, CA 90505
USA**

**+1 310 791 8213 (Telephone)
+1 310 791 6108 (Fax)**

**MX Marine (UK)
Ocean Quay
Southampton SO14 5QY
United Kingdom**

**+44(2380) 33 99 22 (Telephone)
+44(2380) 33 03 45 (Fax)**

www.mx-marine.com

How To Contact Us?

Contact your local MX-Marine, Leica dealer for:

- Installation, Service, & Technical Support
- Sales of Accessories
- Hardware and Software Upgrades

Unlike many other consumer electronics industries which only sell consumer electronic devices, your marine dealer is often your best advisor for installation and service of your new AIS unit. MX-Marine, Leica strongly encourages you to utilize the knowledge and experience of your sales and service dealer.

Should you need to contact us directly for new sales, upgrades, repair service, or technical support, we can be reached at the following:

International:

MX-Marine (USA)
23868 Hawthorne Blvd., Suite 201
Torrance, California 90505
USA

+1 310 791 8213 (Telephone)
+1 310 791 6108 (Fax)

In Europe:

MX Marine (UK)
Ocean Quay
Southampton SO14 5QY
United Kingdom

+44(2380) 33 99 22 (Telephone)
+44(2380) 33 03 45 (Fax)

Email: sales@mx-marine.com
support@mx-marine.com

Table of Contents

1	General	1
1.1	Software Releases	1
1.2	General Recommendations for Installation, Maintenance and Repair Work	1
1.3	Safety Warnings	1
2	Overview	3
2.1	Supplied Equipment	3
2.2	Compatibility with Other Systems	3
2.3	MX535 Transponder with MX420 CDU	4
2.4	MX535 Transponder Overview	5
3	Installation	6
3.1	General Requirements	6
3.2	Installation Overview	
3.2.1	Survey	6
3.2.2	Step-by-step Installation Procedure	6
3.2.3	MX535 Connection Diagram	7
3.3	Components and Interfaces	7
3.3.1	General Interface Description	8
3.3.2	Interface NMEA Description	9
3.3.2.1	Sensor – Interface CH1, CH2, CH3	9
3.3.2.2	ECDIS – Presentation Interface CH4	9
3.3.2.3	PILOT Port CH5	10
3.3.2.4	LONG RANGE CH8	10
3.3.2.5	DGPS – DGNSS CH9	11
3.3.2.6	ALARM CIRCUIT	11
3.4	Sensor Interface Definitions	11
3.4.1	Sensor Notes	12
3.4.2	Sensor Hardware Installation	13
3.4.3	Priority Handling of Sensor Sentence	14
3.4.4	Pin-Description AIS Cable/Socket 50-Pins	19
3.5	Installation of VHF/GPS Antennas	21
3.5.1	VHF Antenna Installation	21
3.5.2	GNSS Antenna Installation	22
3.6	Specific Recommendations	23
3.6.1	Recommendations Concerning AIS Systems	23
3.6.2	Recommendations Concerning Installation of Transponder Unit	23
3.6.3	Recommendations Concerning Installation of VHF Antenna	23
3.6.4	Recommendations Concerning Installation of GPS Antenna	23
3.6.5	Recommendations Concerning Redundancy	24
3.6.6	Emergency Power Source	24

4	Technical Data	25
4.1	Technical Information	25
5	Setting-to-Work/Configuration	27
5.1	Setting-to-Work	27
5.2	Software Versions	27
5.3	Configuration	27
5.3.1	Configuration with MX420/MKD CDU	27
5.4	Testing	27
6	Repair/Maintenance	28
6.1	Trouble Shooting	28
6.1.1	Hints	28
7	Fault Code List	31
8	Cabling Documents	33
9	PRODUCT WARRANTY	35

List of Abbreviations

This list also contains abbreviations which are not used in this manual but in additional documentation.

A

AIS Universal shipborne **A**utomatic Identification **S**ystem

B

BIIT Built-In Integrity Test

C

COG Course Over Ground

CDU Control and Display Unit (MX420/MKD)

D

DCU Display and Control Unit (MX420/MKD)

DSC Digital Selective Call

E

ECDIS Electronic Chart Display and Information System

H

HDG Heading

L

LR Long Range

M

MAC Medium Access Control

MKD Minimum Keyboard and Display

MMSI Maritime Mobile Service Identity

P

PDP Primary Display Port (Presentation Interface)

PP Pilot Port (Auxiliary Display Port)

S

SOG Speed Over Ground

U

UAIS Universal shipborne AIS

V

VDL VHF Data Link

VDM Serial output message containing VDL information (IEC 61162-1)

VDO Serial output message containing VDL information (IEC 61162-1) (from own ship)

1 General

This Technical & Installation Manual is the installation manual for the MX535 AIS Transponder. It also contains information about the antennas (GPS and VHF) and cabling used by the MX535.

Related Documents

MX420 Operator's Manual (P/N 3508 102 70040)

1.1 Software Releases

MX535

This manual is valid for all software versions of the MX535. See also Section 5.2.

MX420

The CDU must have the program version V2.0(841) or later to work properly with the MX535 (NAUTICAST) AIS transponder.

1.2 General Recommendations for Installation, Maintenance and Repair Work

MX-Marine Company gives advice and recommendations for the arrangement of MX-Marine equipment and the installation sites. A prerequisite is that the necessary drawings of the ship should be made available in good time.

The advice and recommendations contained in this manual are given on the basis of our up-to-date practical experience and to the best of our knowledge. However, they are given without any commitment. As far as is permissible, any liability on the part of MX-Marine for resulting damage is expressly ruled out, regardless of whether the damage is of a direct or indirect nature.

Unusual shipbuilding shapes, additions or superstructures as well as environmental influences can impair the functioning of the equipment. We are, of course, willing to help the customer with optimising solutions subject to suitable commercial arrangements.

The customer is responsible for ensuring that the MX-Marine equipment is installed properly according to our instructions and in compliance with the regulations issued by the relevant classification society and national authorities.

1.3 Safety Warnings



WARNING

**This unit contains electrostatic sensitive devices.
Observe precautions for handling.**

The discharge of electrostatic energy into a semiconductor can destroy the semiconductor or change its properties. Before a unit's housing is opened to remove or touch a board, the service equipment, Order No. 586-5011, must be used.

1. The mat must be positioned at the workplace.
2. The potential equalization cable must be connected to the snap fastener and the clamp to a suitable protective earth contact. The cable contains a 1 M Ω resistor, which must not be removed.
3. The wristband must be put on. When the spiral cable is connected to the snap fastener, the discharge line is established.
4. Thoroughly grounded soldering, measurement and test tools must be used. If these tools are supplied with power from the 110 or 230 VAC mains, a fault current plug must protect this supply.

Boards and units that contain ESD-endangered semiconductors are marked with the symbol shown above.

All assisting persons who might come into contact with the endangered boards must also use the ESD equipment.



DANGER

It is not permissible to connect the ship's mains to the system before setting-to-work by a qualified technician. The mains must be switched off (e.g. by means of a common isolating switch or a circuit breaker) in the ship's supply or the mains cable must be disconnected until setting-to-work takes place.

If a synchro is connected via an appropriate interface, dangerous voltages might be present, even although all supplies to the system are switched off.

Capacitors and tubes can store dangerous voltages for several hours, even when they have been disconnected from the supply voltage.

WARNING

Pay attention to the regulations for the prevention of accidents.



DANGER

Even when the system is switched off, there might be a dangerous voltage present on exposed contacts. Therefore, before a unit is opened, it must be ensured that the electrical supply to all units is, and remains, disconnected from the ship's mains.

MX535 AIS Transponder Unit

Technical & Installation Manual

2 Overview

The MX535 is an AIS Transponder Unit, which receives data from other vessels by means of a VHF radio and sends these data to the MX420 Control and Display Unit (CDU) or the ECDIS.

In the opposite direction, the AIS receives data from the external GPS system and the ship's sensors and transmit these data by means of the VHF radio.

Access to these data and access to the VHF radio for a pilot is prepared by means of an additional pilot port.

The AIS has a Long-Range (LR) Port to connect a long-distance communication system, for instance a satellite communication system. In this way, the AIS can be called to send the ship's data. These data are sent back via the long-range port to the questioner.

2.1 Supplied Equipment

The following items are supplied with the MX535 Kit:

<u>Description</u>	<u>Part Number</u>
MX535 AIS system comprising:	9525 200 80800
MX535 Transponder	3508 102 70800
Mounting Kit	3508 102 70820
JB-50 Junction Box (optional)	3508 102 70830
AIS Cable	3508 102 70840
GPS/VHF Cable	3508 102 70850
MX535 N(m) / RG214(crimp)	3508 102 70860
MX535 Technical & Installation Manual	3508 102 70870

2.2 Compatibility with Other Systems

The MX535 AIS transponder can be used with the following systems:

- MX420/AIS Control and Display Unit (CDU) Version V2.0(841) or later, or MX420 MKD with Program Version V2.0(841) or later
- IMO compliant ECDIS systems (only listening). It is not allowed to transmit data (e.g. VSD, SSD) into the MX535 via an ECDIS.

It is also possible to use the MX535 within systems from other manufacturers, which support the IEC-defined interfaces.

2.3 UAIS MX535 with MX420/AIS or MKD CDU

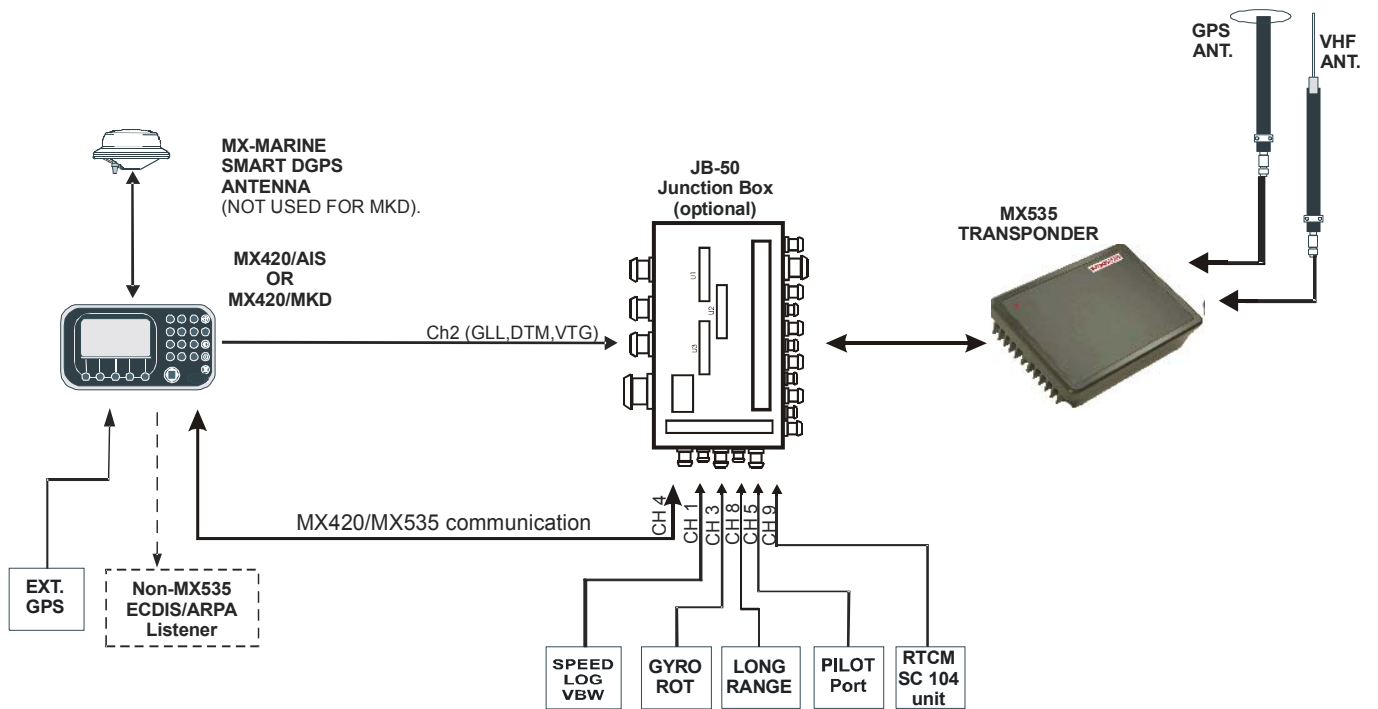

Figure 2.1 - MX535 AIS Transponder with MX420/AIS or MKD CDU

The Display and Control Unit MX420/AIS is used to configure and operate the MX535 transponder unit. In this case, the MX420/AIS or MKD can just be a display. For further information refer to the Operator and Installation Manual of the MX420 Control and Display Unit (CDU).

2.4 MX535 Transponder Overview



Figure 2.2 – MX535 UAIS Transponder

The aluminum housing shown in Fig. 2.2 contains a single Transponder Unit, which consists of the:

- Controller
- Interfaces
- VHF transmitter
- VHF receivers
- GPS receiver.

The housing has two cable connectors (GPS/VHF Interface Cable and AIS Cable) for the connection of:

- GPS antenna
- VHF antenna
- AIS

3 Installation

3.1 General Requirements

Please note that international conventions, regulations, instructions and guidelines have to be adhered to when installing the MX535 AIS transponder.

The following points must be observed before installation can commence:

- Trained service personnel must undertake the installation.
- The MX535 Transponder must be fitted in a suitable place on the bridge.
- The VHF and GPS Antennas must be installed in a suitable position, where excellent reception conditions apply (refer to Section 3.5, Installation of VHF and GPS antennas – page 21)
- All available interfaces must be installed.
- The vessels power supply must suffice, and the GMDSS power supply has to be used.
- Installation of the pilot plug in conning position (close to the pilot working place).

3.2 Installation Overview

3.2.1 Survey

AIS is considered part of the ship's radio station and is surveyed together with radio installation. Surveys on SOLAS Convention ships should be carried out in accordance with the rules laid down in IMO Res. A 746(18) "Survey Guidelines under the harmonised system of survey and certification" (R) 8, and "Protocol of 1988 relating to the International Convention for the Safety of Life at Sea, 1974."

The MX535 system consists of the MX535 Transponder Unit, MX420 CDU, VHF Antenna, Backup GPS Antenna, MX521(MX525) Smart Antenna, and associated cable.

3.2.2 Step-by-Step Installation Procedure

- Use the VHF adapter cable (P/N 3508 102 70850) together with the VHF plug and TNC plug to connect the VHF and GPS antenna cables as well as the antennas.
- The sensors, ECDIS, PC, pilot case, long range devices and auxiliary displays can be connected to the MX535 transponder cabinet by the AIS cable or JB-50 Junction Box (optional). The device is driven by a 24V DC 7A supply, which is connected to the power terminal at the JB-50 Junction Box (optional). The AIS should be connected to an emergency power source. A battery capacity calculation together with GMDSS-equipment is needed! After performing these steps, the MX535 transponder automatically starts operation.
- The MX535 transponder has a ground terminal, which has to be connected to ship ground.

3.2.3 MX535 Connection Diagram

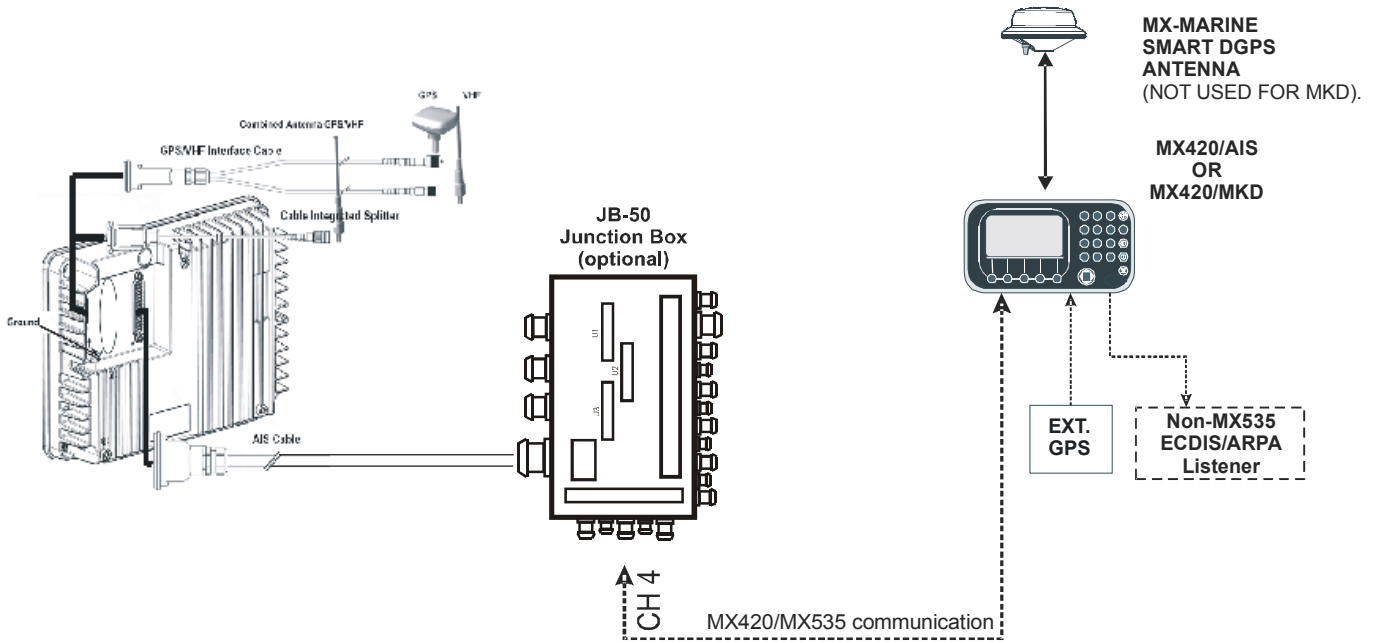

Figure 2.3 – MX535 Connection Diagram

Note: The MX535 JB-50 Junction Box (optional) includes a fuse of 6.3A. If it is not used, then the unit has to be protected against high current by an external slow blow fuse of 6.3A.

3.3 Components and Interfaces

The diagram below illustrates which devices can be connected to the MX535 Transponder. For a detailed description of sensor connecting e.g. an existing Gyro to MX535, refer to Section 3.4. (2.3) "Sensor Installation" on page 12-13.

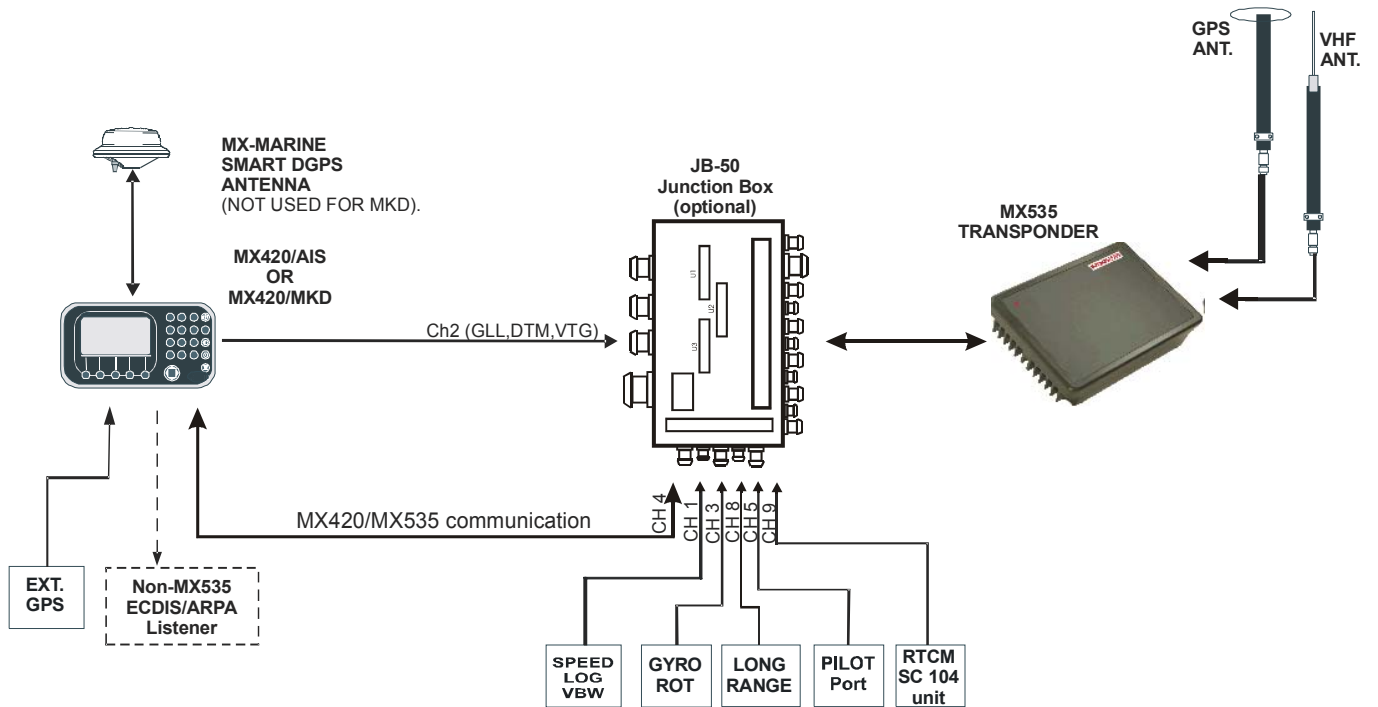

Figure 2.4 – Devices that can be connected to MX535

3.3.1 General Interface Description

Interface	Designation	Speed	Direction
Sensor 1	CH 1	4800 or 38400 bps	Input
Sensor 2	CH 2	4800 or 38400 bps	Input
Sensor 3	CH 3	4800 or 38400 bps	Input
ECDIS	CH 4	38400bps	Input/Output
PILOT	CH 5	38400bps	Input/Output
LONG RANGE	CH 8	38400bps	Input/Output
DGPS (RTCM SC104)	CH 9	9600bps	Input
ALARM CIRCUIT	CH 10	Dry relay contact (power off and alarm state closed)	

3.3.2 Interface NMEA Description

3.3.2.1 External Sensors - Interface on CH1, CH2, CH3

The MX535 AIS transponder requires connection to various sensor devices. MX535(AIS) and MX420/AIS or MKD (CDU) together offer the following configuration options:

- Set up data speed 4800 or 38400 baud.
- Monitor the connected sensor inputs for each sensor channel.
- Analyze the information received from the connected sensor devices.
- Configuration of various NMEA protocols.

The individual options may be repeated until the required configuration for the connected sensor devices is achieved.

3.3.2.2 ECDIS – Presentation Interface CH 4

	Sentence Formatters	Direction	Used Fields
ABK	UAIS Addressed and binary broadcast acknowledgement	Out	All fields are provided for Input and Output. For further information please refer to IEC 61993-2 / NMEA 0183 HS V3.0 for detailed field information.
ACA	AIS Channel assignment message	In / Out	
ACK	Acknowledge Alarm	In	
AIR	UAIS Interrogation Request	In	
ALR	Set Alarm State	Out	
ABM	UAIS Addressed binary and safety related message	In	
BBM	UAIS Broadcast Binary Message	In	
DSC	Digital Selective Calling Information	Out	
DSE	Expanded Digital Selective Calling	Out	
DSI	DSC Transponder Initialize	Out	
DSR	DSC Transponder Response	Out	
LRI	UAIS Long-Range Interrogation	Out	
LRF	UAIS Long-Range Function	Out	
SSD	Station Static Data	In	
TXT	Text Transmission	Out	
VSD	Voyage Static Data	In	
VDM	UAIS VHF Data-link Message	Out	
VDO	UAIS VHF Data-link Own-vessel report	Out	

3.3.2.3 PILOT Port CH 5

The used sentence formatters for the pilot plug are the same as those listed for the ECDIS port (CH 4).

Note:

A pilot input/output port is part of an AIS Class A installation. A plug connected to this port should be installed on the bridge near the pilot's operating position, so that a pilot can connect a Personal Pilot Unit (PPU) if required. Also, a power connector for the pilot unit should be available nearby.

The pilot plug should be configured as follows: (Refer to SUB-COMMITTEE ON SAFETY OF NAVIGATION NAV48/18 2.4.2002)

AMP/Receptacle (Square Flanged (-1) or Free-Hanging (-2)), Shell size 11, 9-pin, Std. Sex 206486-1/2 or equivalent with the following connections:

- Tx A (out-) is connected to Pin 1
- Tx B (out+) is connected to Pin 4
- Rx A (in-) is connected to Pin 5
- Rx B (in+) is connected to Pin 6
- Shield is connected to Pin 9

3.3.2.4 LONG RANGE CH 8

The AIS long range function requires a compatible long range communication system (e.g. Inmarsat-C or MF/HF radio as part of GMDSS). This connection is required in order to activate the long range function of the AIS. Its input/output port must meet the IEC 61162-2 requirements.

Sentence Formatters		Direction
LRI	UAIS Long Range Interrogation	Input
LRF	UAIS Long-Range Function	Input / Output
LR1	UAIS Long-Range Reply Sentence 1	Output
LR2	UAIS Long-Range Reply Sentence 2	Output
LR3	UAIS Long-Range Reply Sentence 3	Output
Field Information: All fields are provided for input and output. For further information please refer to IEC 61993-2 / NMEA 0183 HS V3.0 for detailed field information.		

3.3.2.5 DGPS – DGNSS Channel 9

Field / Protocol information:

All fields are provided for further information; please refer to ITU-R M.823-2 / RTCM SC 104 for detailed field information.

3.3.2.6 ALARM CIRCUIT

The AIS requires that an alarm output (relay) must be connected to an audible alarm device (MX420/AIS or MKD CDU) or the ship's alarm system, if available.

3.4 Sensor Interface Definitions

All interface ports of MX535 Transponder comply with IEC-61162-1 / -2 and NMEA-0183 HS 3.0 specifications (aligned to RS422 parameters).

Talker drive circuits

The maximum output current is $I_{max} = 50mA$ on each port. The drive circuit meets the requirements of ITU-T V.11.

Listener Receiver Circuits

Multiple listeners may be connected to a single talker. Optional termination resistors (120Ohm) for the input lines are provided in the JB-50 Junction Box (optional). The input terminals A, B and C are electrically isolated from the remaining electronics of the listening device.

The input impedance is 30kOhm between A and B lines, disregarding the connection of termination resistors. The minimum input voltage is $\pm 0.3V$.

The listener's receiver circuit complies with ITU-T V.11.

Electrical isolation

There are no direct electrical connections between the signal lines A and B.

The signal ground C must not be connected to the ship main ground or power line!

This isolation is in accordance with IEC 60945.

Maximum voltage on the bus

The maximum applied voltage between signal lines A and B and between either line and ground C is in accordance with ITU-T V.11. For protection against incorrect wiring and for unintended connection to older TALKER models, all receiver circuit devices are capable of withstanding 15 V between both lines and signal ground for an indefinite period.

Data transmission

Data is transmitted in serial asynchronous form in accordance with IEC 61162-1. The first bit is a start bit, and is followed by data bits, whereby the least significant bit is first.

The following parameters are used:

- Baud rate 4800 (bits/s)
- Data bits 8 (D7 = 0), parity none
- Stop bits 1.

3.4.1 Sensor Notes

External Sensor

The AIS has interfaces (configurable as IEC 61162-1 or 61162-2) for position, bottom track (BT) speed, heading and rate of turn (ROT) sensors. In general, sensors installed in compliance with other carriage requirements of SOLAS Chapter V should be connected to the AIS System.*1. The sensor information transmitted by AIS should be the same information being used for navigation of the ship. Interfacing problems might occur if the existing on board sensors do not have serial (IEC 61162) outputs. A converter is needed to translate the non-conforming data to IEC 61162 – sensor data. For Example, Nauticast Converter type NAU-Z002 or Raytheon Nav Data Repeater 133-812.

The fact that AIS is fitted on board a vessel does NOT entail the need to install additional sensors other than those stated in the carriage requirements.

External GPS

GNSS position sensors normally have IEC 61162 outputs suitable for direct AIS interfacing. However, it is important to note that:

- The Geodetic Datum of the position data is transmitted by the sensor in WGS84 so that an IEC 61162 DTM sentence is configured.
- The MX420/AIS or MKD is able to handle three reference points -- two external GPS antennas, and one internal GPS antenna.
- External GPS antennas SHOULD NOT be connected directly to the MX535.

External Heading

A gyrocompass providing heading information (HDT) is a mandatory sensor input to the AIS. A converter unit (synchro or step-signal converter to NMEA 0183 v.3.0) for example Nauticast Converter type NAU-Z002 or Raytheon Nav Data Repeater 133-812 will be needed for AIS connection in the case that the ship's gyrocompass does not provide IEC 61162 output.

External Speed and Course

If a bottom track (BT) log for speed over ground (SOG) is available, it may be connected. A converter (for example Raytheon converter type: 133-812) is needed if the BT-log does not provide IEC 61162 outputs

External Rate of Turn

Not all ships will carry a Rate-Of-Turn (ROT) indicator according to IMO A.526. However, if a rate-of-turn indicator is available and it includes an IEC 61162 interface, it should be connected to the AIS.

If ROT information is not available from a ROT indicator, it may (optionally) be derived from heading information through:

- The gyrocompass itself,
- An external converter unit (see Heading),
- The AIS itself (calculated ROT).

3.4.2 Sensor Hardware Installation

Installation of an RS422 serial interface:

In most cases, the output from a GPS is already being used by existing navigation equipment. It is possible to split an RS-422 output for two devices. If the signal becomes too low, then an NMEA splitter has to be used.

Example for single talk multi-listener connection:

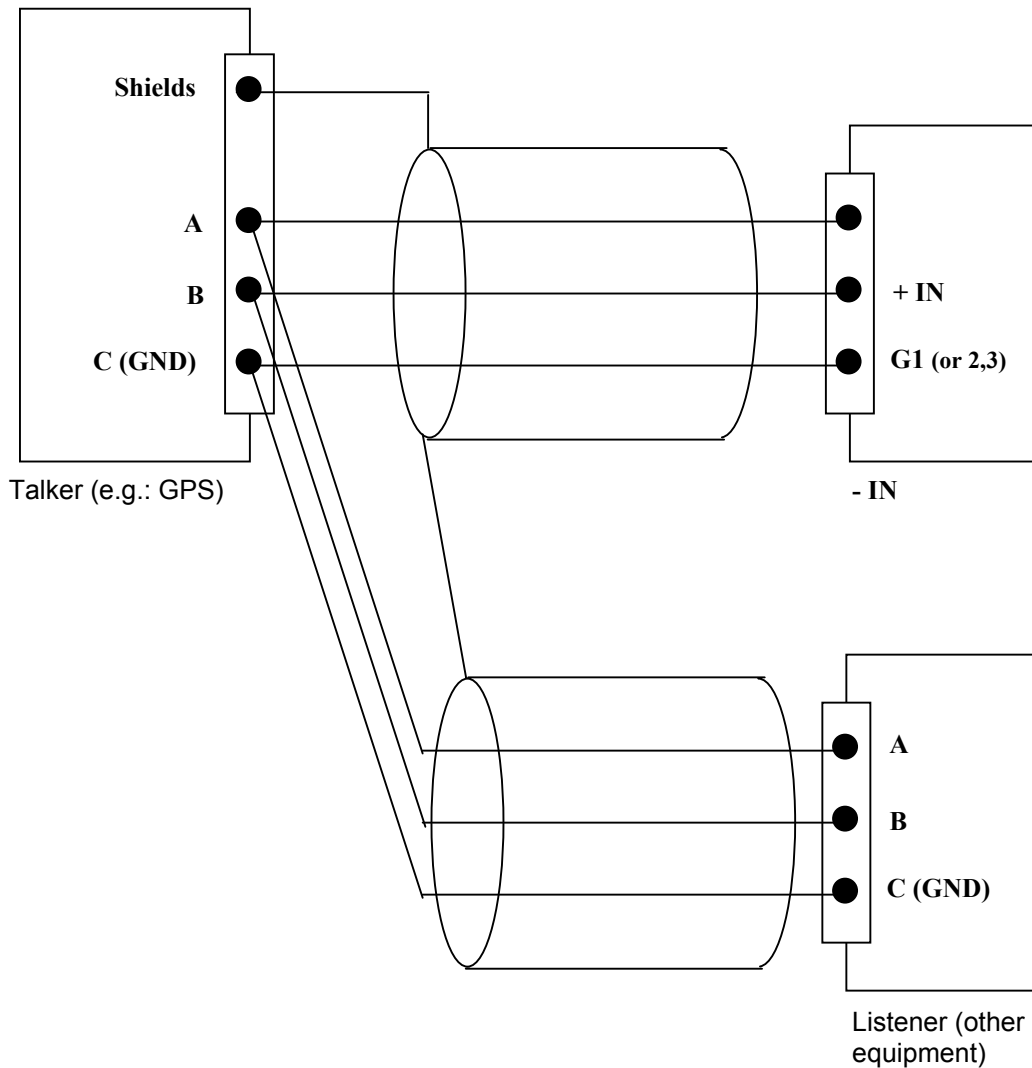

Each interface on the Transponder is a RS422 serial interface.
The shield or ship main ground should not be connected with the signal ground (GND).

3.4.3 Priority Handling of Sensor Sentence

The following table shows the priority handling of NMEA sentences. The sentences, which are treated with higher priority, are listed first.

Positioning System	Source	Priority
HIGH		
Time of Position		
Latitude/Longitude	GNS	
Position accuracy	GLL	
	GGA	
	RMC	
Rate of Turn (ROT)	ROT	
Reference Datum	DTM	
Speed over Ground	VBW	
	VTG	
	OSD	
	RMC	
Heading	HDT	
	OSD	
RAIM Indicator	GBS	
LOW		

Supported NMEA-0183 Sentences

DTM - Reference

```

      1   2 3   4 5   6 7   8   9
      |   | |   | |   | |   |   |
$--DTM,ccc,a,x.x,a,x.x,a,x.x,ccc*hh<CR><LF>
    
```

Field Numbers:

- 1) Local datum code (W84,W72,S85,P90,999-user defined, IHO datum code)
- 2) Local datum subdivision code
- 3) latitude offset, minutes
- 4) N or S (North or South)
- 5) longitude offset, minutes
- 6) E or W (East or West)
- 7) altitude offset, meters
- 8) Reference datum code ((W84,W72,S85,P90)
- 9) CRC

Used Fields: 1,8

- 1: Local datum code
- 8: Reference datum code

MX535 UAIS Transponder Unit

Technical & Installation Manual

GGA - Positioning System Fix Data

Time, Position and fix related data form GPS receiver.

```

                                     11
      1           2           3 4           5 6 7 8           9 10 | 12 13 14 15
      |           |           | |           | | | |           | | | | | | | |
$--GGA,hhmmss.ss,llll.ll,a,yyyy.yy,a,x,xx,x.x,x.x,M,x.x,M,x.x,xxxx*hh
```

Field Numbers:

- 1) UTC
- 2) Latitude
- 3) N or S (North or South)
- 4) Longitude
- 5) E or W (East or West)
- 6) GPS Quality Indicator,
0 - fix not available,
1 - GPS fix,
2 - Differential GPS fix
- 7) Number of satellites in view, 00 - 12
- 8) Horizontal Dilution of precision
- 9) Antenna Altitude above/below mean-sea-level (geoid)
- 10) Units of antenna altitude, meters
- 11) Geoidal separation, the difference between the WGS-84 earth ellipsoid and mean-sea-level (geoid), \- \ means mean-sea-level below ellipsoid
- 12) Units of geoidal separation, meters
- 13) Age of differential GPS data, time in seconds since last SC104 type 1 or 9 update, null field when DGPS is not used
- 14) Differential reference station ID, 0000-1023
- 15) CRC

Used Fields: 1,2,3,4,5,6,7

1:UTC 2:Lat 3:LaInd 4:Lon
5:LoInd 6:Acc 7:Sat

GLL - Position - Latitude/Longitude

```

      1           2 3           4 5           6 7 8
      |           | |           | |           | | |
$--GLL,llll.ll,a,yyyy.yy,a,hhmmss.ss,A,a*hh<CR><LF>
```

Field Numbers:

- 1) Latitude
- 2) N or S (North or South)
- 3) Longitude
- 4) E or W (East or West)
- 5) Universal Time Coordinated (UTC)
- 6) Status A - Data Valid, V - Data Invalid
- 7) Mode indicator
- 8) CRC

Used Fields: 1,2,3,4,5,6,7

1:Lat 2:LaInd 3:Lon 4:LoInd
5:UTC 6:Valid 7:Acc

GNS - Fix Data

```

      1          2          3 4          5 6          7 8          9          10 11 12 13
      |          |          | |          | |          | |          |          | | | |
$--GNS,hhmmss.ss,llll.ll,a,yyyyy.yy,a,c--c,xx,x.x,x.x,x.x,x.x,x.x*x*hh

```

Field Numbers:

- 1) UTC
- 2) Latitude
- 3) N or S (North or South)
- 4) Longitude
- 5) E or W (East or West)
- 6) Mode indicator
- 7) Total number of satellites in use,00-99
- 8) HDROP
- 9) Antenna altitude, meters, re:mean-sea-level(geoid)
- 10) Goeidal separation meters
- 11) Age of diferential data
- 12) Differential reference station ID
- 13) CRC

Used Fields: 1,2,3,4,5,6,7

1:UTC 2:Lat 3:LaInd 4:Lon
5:LoInd 6:Acc 7:Sat

RMC - Minimum Navigation Information

```

      1          2 3          4 5          6 7          8          9          10 11| 13
      |          | |          | |          | |          |          |          | | | |
$--RMC,hhmmss.ss,A,llll.ll,a,yyyyy.yy,a,x.x,x.x,ddmmyy,x.x,a,a*hh<CR><LF>

```

Field Numbers:

- 1) UTC Time
- 2) Status, V = Navigation receiver warning
- 3) Latitude
- 4) N or S
- 5) Longitude
- 6) E or W
- 7) Speed over ground, knots
- 8) Course over Ground, degrees true
- 9) Date, ddmmyy
- 10) Magnetic Variation, degrees
- 11) E or W
- 12) Mode Indicator
- 13) CRC

Used Fields: 1,2,3,4,5,6,7,8,9,10,11,12

1:UTC 2:Valid 3:Lat 4:LaInd 5:Lon 6:LoInd
7:SOG 8:COG 9:Date 10:MagV 11:MagIn 12:Acc

MX535 UAIS Transponder Unit

Technical & Installation Manual

VBW - Ground/Water Speed

```
      1  2  3 4  5  6 7
      |  |  | |  |  | |
$--VBW,x.x,x.x,A,x.x,x.x,A*hh<CR><LF>
Field Numbers:
```

Used Fields: 1,5,6,7,8,9
1:COG 5:SOG 6:SOGIn 7:SOG 8:SOGIn 9:Valid

OSD - Ship Data

```
      1  2 3  4 5  6 7  8  9 10
      |  | |  | |  | |  |  | |
$--OSD,x.x,A,x.x,a,x.x,a,x.x,x.x,a*hh<CR><LF>
Field Numbers:
```

- 1) Heading, degrees true
- 2) Status, A = Data Valid
- 3) Vessel Course, degrees True
- 4) Course Reference
- 5) Vessel Speed
- 6) Speed Reference
- 7) Vessel Set, degrees True
- 8) Vessel drift (speed)
- 9) Speed Units
- 10) CRC

Used Fields: 1,2,3,4,5,6,9
1:HDT 2:HDTVal 3:COG 4:COGRef
5:SOG 6:SOGRef 9:SOGInd

HDT - True Heading

```
      1  2 3
      |  | |
$--HDT,x.x,T*hh<CR><LF>
Field Numbers:
```

- 1) Heading Degrees, true
- 2) T = True
- 3) CRC

Used Fields: 1,2
1:HDT 2:HDTRu

ROT - Rate of Turn

```
      1  2 3
      |  | |
$--ROT,x.x,A*hh<CR><LF>
Field Numbers:
```

- 1) Rate Of Turn, degrees per minute, \- means bow turns to port
- 2) Status, A means data is valid
- 3) CRC

Used Fields: 1,2
1:ROT 2:Valid

Versions of NMEA Sentences

RMC

v2.30 - \$GPRMC,122500.00,A,5330.1234,N,01001.2345,E,11.2,352.2,120202,2.0,E,A
v2.20 - \$GPRMC,122500.00,A,5330.1234,N,01001.2345,E,11.2,352.2,120202,2.0,E

GLL

v2.30 - \$GPGLL,5330.1234,N,01001.2345,E,141800.00,A,A
v2.00 - \$GPGLL,5330.1234,N,01001.2345,E,141800.00,A
v1.50 - \$GPGLL,5330.1234,N,01001.2345,E

GGA

v2.00 - \$GPGGA,092854,5330.1234,N,01001.2345,E,1,3,1.2,65.2,M,45.1,M,,
v1.50 - \$GPGGA,092854,5330.1234,N,01001.2345,E,1,3,1.2,65.2,M,45.1,M

VBW

v2.30 - \$VDVBW,11.00,01.00,A,12.00,02.00,A,,V,,V
v2.20 - \$VDVBW,11.00,01.00,A,12.00,02.00,A

VTG

v2.30 - \$GPVTG,350.0,T,,M,10.0,N,,K,A
v2.20 - \$GPVTG,350.0,T,,M,10.0,N,,K

OSD

v2.30 - \$INOSD,359.9,A,5.2,B,12.6,B,150.0,1.2,N
v2.20 - \$INOSD,359.9,A,5.2,B,12.6,B,150.0

MX535 UAIS Transponder Unit

Technical & Installation Manual

3.4.4 Pin-Description AIS-Cable / Socket 50-Pins

TxA → out –
 TxB → out +
 RxA → in –
 RxB → in +

AIS Cable/Socket (Sub-D 50 Plug)					
1	CH5_out+			34	Spare
		18	Ch4_out+		
2	CH5_out-			35	Spare
		19	CH4_out-		
3	CH5_gnd			36	Spare
		20	CH4_gnd		
4	CH5_in+			37	Spare
		21	CH4_in+		
5	CH5_in-			38	Spare
		22	CH4_in-		
6	CH6_Vin			39	CH9_gnd
		23	CH8_in+		
7	CH6_gnd			40	CH9_out-
		24	CH8_in-		
8				41	CH9_in-
		25	CH8_gnd		
9				42	CH9_in+
		26	CH8_in+		
10	CH1_in-			43	CH9_out+
		27	CH8_in-		
11	CH1_gnd			44	Spare
		28	Spare		
12	CH1_in+			45	Spare
		29	CH3_in-		
13	CH2_in-			46	
		30	CH3_gnd		
14	CH2_gnd			47	
		31	CH3_in+		
15	CH2_in+			48	Vin_gnd
		32	Vin_gnd		
16	Vin+ (24V)			49	Vin_gnd
		33	Vin+ (24V)		
17	Vin+ (24V)			50	Spare
CH1	Sensor	CH4	MX420/AIS or MKD	CH8	Long Range
CH2	Sensor	CH5	aux. Display	CH9	DGNSS
CH3	Sensor	CH6	opt. 61162-3		
Spare	Do not use				



AIS Plug and Socket

Black BK
 White WH
 Red RD
 Green GN
 Brown BR
 Blue BL
 Orange OR
 Yellow YL
 Violet VI
 Gray SL (Slate)
 Pink PK

Pin-Description AIS-Connector:

AIS -Cable Sub-D 50 Plug

Note:
 TxA → out -
 TxB → out +
 RxA → in -
 RxB → in +

Channel 1,2,3
 MX420/AIS
 or MKD
 Pilot Port
 Long Range
 DGPS

CH1_in+ 12
 CH1_in- 10
 CH1_gnd 11
 CH2_gnd 14
 CH2_in+ 15
 CH2_in- 13
 CH3_in+ 31
 CH3_in- 29
 CH3_gnd 30
 CH4_gnd 20
 CH4_in+ 21
 CH4_in- 22
 CH4_out+ 18
 CH4_out- 19
 CH5_in+ 4
 CH5_in- 5
 CH5_out+ 1
 CH5_out- 2
 CH5_gnd 3
 CH8_gnd 25
 CH8_in+ 26
 CH8_in- 27
 CH8_out+ 23
 CH8_out- 24
 CH9_in+ 42
 CH9_in- 41
 CH9_out+ 43
 CH9_out- 40
 CH9_gnd 39
 Spare_gnd 36
 Spare_in+ 35
 Spare_in- 34
 Spare_out+ 38
 Spare_out- 37

16 ● + 24 VDC/max 5A rd
 17 ● + 24 VDC rd
 33 ● + 24 VDC rd
 48 ● 0 V bl
 49 ● 0 V bl
 32 ● 0 V bl

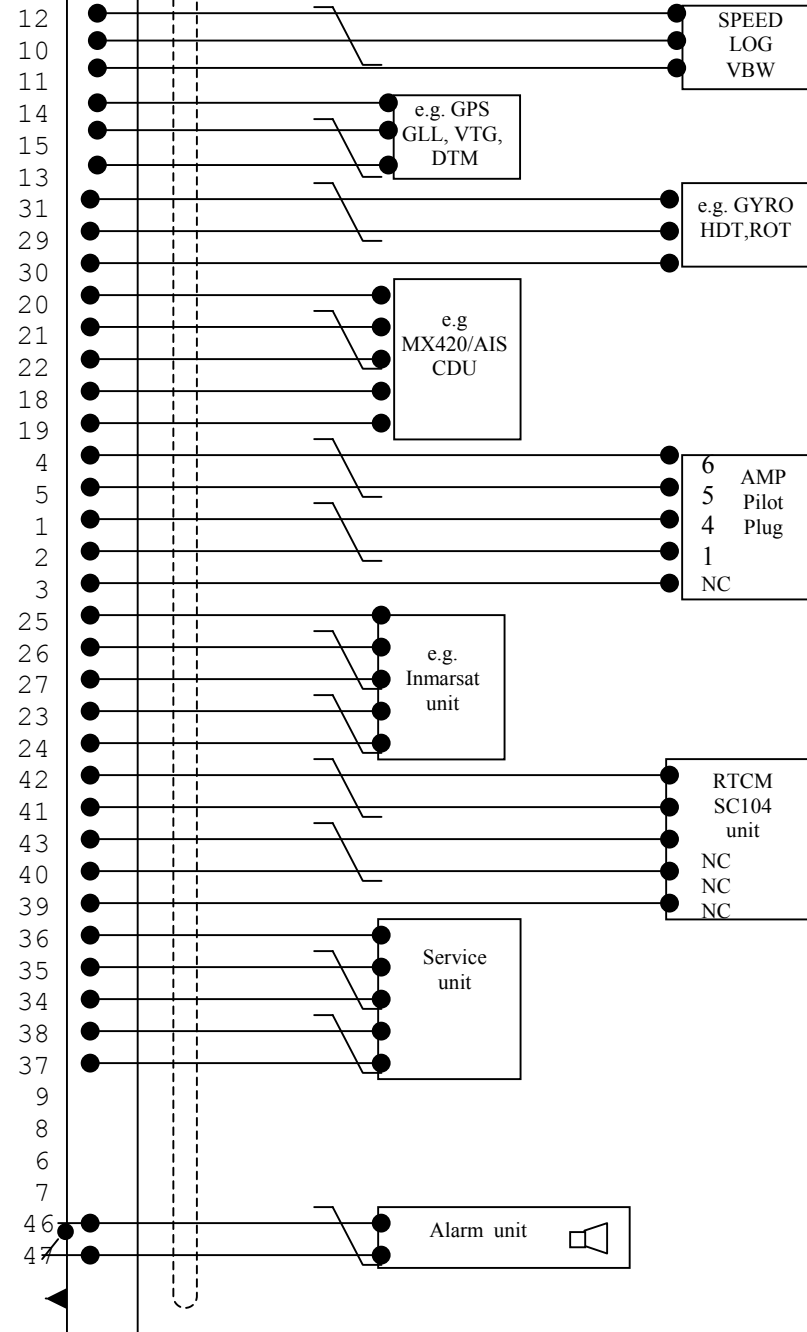

AIS-Cable Open

1 WH/BK
 2 BR/BK
 3 SL/GN
 7 YL/SL
 5 PK/GN
 6 YL/PK
 9 GN/BL
 10 YL/BL
 11 GN/RD
 17 YL/RD
 13 GN/BK
 14 YL/BK
 15 SL/BL
 16 PK/BL
 19 SL/RD
 20 PK/RD
 21 SL/BK
 22 PK/BK
 23 WH/SL
 29 SL/BR
 25 WH/PK
 26 PK/BR
 27 WH/BL
 28 BR/BL
 31 WH/YL
 32 YL/BR
 33 WH/GN
 34 BR/GN
 35 SL/PK
 41 RD/BL
 37 SL
 38 PK
 39 GN
 40 YL
 43 WH
 44 BR
 45 RD
 46 BL
 49 BK
 50 VI

3.5 Installation of VHF / GPS Antennas

Interference to the Ship's VHF Radiotelephone

The AIS ship borne equipment, like any other ship borne transceiver operating in the VHF maritime band, may cause interference to a ship's VHF radiotelephone. Because AIS is a digital system, this interference may occur as a periodic (e.g. every 20 seconds) soft clicking sound on the ship's radiotelephone. This may become more noticeable if the VHF radiotelephone antenna is located close to the AIS VHF antenna, and when the radiotelephone is operating on channels near the AIS operating channels (e.g. channels 27, 28 and 86).

Attention should be paid to the location and installation of the various antennas, in order to support the antenna characteristics in the best possible way.

3.5.1 VHF Antenna Installation

Antenna Location

Location of the mandatory AIS VHF-antenna should be carefully considered. Digital communication is more sensitive than analogue/voice communication to interference created by reflections caused by obstructions such as masts and booms. It may be necessary to relocate the VHF radiotelephone antenna to minimize interference effects.

To minimise interference effects, the following guidelines apply:

The AIS VHF antenna should have omni directional vertical polarisation providing 3 to 5 dB gain. The AIS VHF antenna should be placed in an elevated position, as free standing as possible, with a minimum of 2 metres in horizontal direction from constructions made of conductive materials. The antenna should not be installed close to any large vertical obstruction. The AIS VHF antenna should have a visible sky of 360°. The AIS VHF antenna should be installed at least 3 meters away from interfering high-power energy sources such as radar and other transmitting radio antennas, and out of the way of the transmitting beam. There should not be more than one antenna on each level. The AIS VHF antenna should be mounted directly above or below the ship's primary VHF radiotelephone antenna, with no horizontal separation and a minimum of 2 metres vertical separation. If it is located on the same level as other antennas, the distance apart should measure at least 10 metres.

Cabling

The cable should be kept as short as possible to minimise attenuation of the signal. Double shielded coaxial cables equal to or better than RG214 are recommended.

RG214 at VHF attenuation per meter of app. 0.07 dB/m (45m = 3.15db)

VHF AIS frequency app. 162MHz

All outdoor connectors on the coaxial cables should be fitted with preventive isolation, such as shrink-stocking with silicone to protect the antenna cable against water penetration. Coaxial cables should be installed in separate signal cable channels/tubes, and at least 10 cm away from any power supply cables. Crossing of cables should take place at right angles (90°). Coaxial cables should not be exposed to sharp bends, which may lead to changes to the characteristic impedance of the cable. The minimum bend radius should be 5 times the cables outside diameter.

Grounding

Coaxial down-leads must be used for all receiving antennas, and the coaxial screen should be connected to the ground at one end.

3.5.2 GNSS Antenna Installation

Antenna Location

The GNSS antenna must be installed where it has a clear view of the sky, so that it accesses the horizon freely through 360°, with a vertical observation of 5 to 90 degrees above the horizon. Small diameter obstructions, such as masts and booms, do not seriously impair signal reception, but such objects must not eclipse more than a few degrees of any given bearing.

The antenna must be located at least three meters away from, and out of the transmitting beam of high-power transmitters (S-Band Radar and/or Inmarsat systems). This includes the ship's own AIS VHF antenna, if it is designed and installed separately.

If a DGNSS system is included or connected to the AIS system, the installation of the antenna should be undertaken in accordance with IEC 61108-4, Edition 1.

Cabling

To achieve optimum performance, the gain of the antenna pre-amplifier should match the cable attenuation. The resulting installation gain (pre-amplifier gain - cable attenuation) should be within 0 to 10 dB. RG214 at GPS attenuation per meter of app. 0.35 dB/m (45m = 15.75dB)
GPS frequency app. 1.2GHz

The coaxial cable between the antenna and the AIS ship borne station connector should be routed directly, in order to reduce electromagnetic interference. The cable should not be installed close to high-power lines, such as radar or radio-transmitter lines, or near the AIS VHF antenna cable. A space of one meter or more is recommended in order to avoid degradation due to RF-coupling. Crossing of antenna cables should take place at 90 degrees, to minimise magnetic field coupling.

Antenna Layout

The position of the VHF und GNSS – antennas must be added to the existing antenna layout of the vessel.

Power Supply

The MX535 transponder must be supplied from the emergency power source. A further requirement is to connect AIS to the reserve power source of the GMDSS. A new battery capacity calculation must then be undertaken.

Following documents are needed for the installation approval of the classification

- Antenna Layout (arrangement)
- Battery Calculation
- Connection / Block – Diagram with locations
- Type Approval Certificate

3.6 Specific Recommendations

3.6.1 Recommendations Concerning AIS Systems

Recommendations for the installation of AIS systems are published in the IMO document NAV 48/WP.1. See this document for further information. The following sections also contain information, which has been taken from IMO NAV 48/WP.1.

3.6.2 Recommendations Concerning the Installation of the Transponder Unit

The Transponder Unit should be mounted on a vertical bulkhead. A distance of at least 300 mm from other devices must be ensured above and below the housing for sufficient air circulation.

3.6.3 Recommendations Concerning the Installation of the VHF Antenna

The digital signals of the AIS may occur as a periodic clicking sound on a ship's radiotelephone. This effect may become stronger when the VHF antenna of the AIS is located near the VHF radiotelephone antenna and when the radiotelephone is operating on channels near the AIS operating channels (for example channels 27, 28, 86).

The antenna should be placed in an elevated position that is as unobstructed as possible, with a minimum of 2 m in the horizontal direction from any structures made of conductive materials. The antenna should not be installed close to any large vertical obstruction. The objective for the VHF antenna is that it should "see" the horizon freely through 360°.

The VHF antenna should be installed safely away from interfering high-power energy sources such as the radar scanner and other transmitting radio antennas, preferably at least 3 m away from and out of the transmitting beam.

Ideally there should not be more than one antenna on the same level. The AIS VHF antenna should be mounted directly above or below the ship's primary VHF radiotelephone antenna, with no horizontal separation and with a minimum of 2 m vertical separation. If it is located on the same level as other antennas, the distance apart should be at least 10 m.

3.6.4 Recommendations Concerning the Installation of the GPS Antenna

The GPS antenna should be installed where it has a clear "view" of the sky. The objective is that it should "see" the horizon freely through 360° with a vertical observation sector of 5...90° above the horizon. Small diameter obstructions, such as masts and booms, do not seriously degrade signal reception, but such objects should not eclipse more than a few degrees of any given bearing.

Locate the antenna at least 3 m away from and out of the transmitting beam of high-power transmitters (S-Band radar and/or INMARSAT systems). This includes the ship's own AIS VHF antenna.

3.6.5 Recommendations Concerning Redundancy

If possible, the Transponder Unit should be supplied with the ship's Position sensor data from two different sources, e.g. MX521 Smart DGPS antenna or the MX525 DGPS Sensor or other equivalent sensors).

3.6.6 Emergency Power Source

It is recommended that an emergency power source such as a 24 VDC uninterruptible power supply should be used. See Section 7 for information about the power consumption of the Transponder Unit.

4 Technical Data

4.1 Technical Information

PHYSICAL	
Size in mm / inch (w)	201.26mm / 7.92inch
Size in mm / inch (h)	60mm / 2.36inch
Size in mm / inch (d)	281.26mm / 11.07inch
Weight	2490g / 5.50lb
Operating Temperature	-15°C to +55°C / 5°F to 131°F
POWER SUPPLY	
Supply Voltage (galvanic isolated)	24 V DC (-10% +30%)
Input Current	min.7 A (24V)
INTERFACES	
Number of Data Ports	3 Input / 4 I-O / 1 Output
IEC 61162-1/2	(RS422 / NMEA 0183)
ITU-R M.823-2	(RS422 / RTCM SC104)
Bitrate	
CH1 Sensor Input; (i.E.: GPS)	4800 or 38400 bps
CH2 Sensor Input; (i.E.: GYRO)	4800 or 38400 bps
CH3 Sensor Input; (i.E.: HDG)	4800 or 38400 bps
CH4 ECDIS Port (In- / Output) AIS targets, AIS messages	in/ out 38400 bps
CH5 Pilot Port (In- / Output) AIS targets, AIS messages	in/out 38400 bps
CH8 Long Range Port (In- / Output)	in/out 38400 bps
CH9 DGPS correction (In- / Output) (RTCM SC104)	in/out 9600 bps

SPECIFIED STANDARDS	
IMO MSC.74(69) Annex 3	
ITU-R M.1371 (Class A)	
IALA Techn.Clar. of ITU-R M.1371-1 (Ed.1.3)	
IEC 61993-2 (2002)	
IEC 61162-1 (2000)	NMEA 0183-3
IEC 61162-2 (1998)	NMEA 0183-3
IEC 61162-3	NMEA 2000
ITU-R M.823-2	
IEC 61108-1 (1996)	
IEC 60 945 (1996)	
ITU-R M.825-3	
ITU-R M.1084-3	
VHF	
Frequency Range	156 MHz - 162MHz
Channel Spacing	12.5 or 25kHz
Number of RF Channels	3 Receiv. / 1 Transm.
Number of AIS Receivers	2
Number of DSC Receivers	1
Frequency Error	+/- 2.5ppm
VHF TRANSMITTER	
Output Power	2 Watt to 12.5 Watt (adjustable)
Receive to Transmit Switching Time	< 1ms
Transmit release time	< 1ms
Automatic shutdown	1 sec.
Channel switching time	< 25ms
Attack Time	< 1ms

BUILT IN GPS	
Receiver Architecture	12 channel differential
Tracking Capability	12 satellites sim.
Accuracy Horizontal	10m / 2drms *
Accuracy Vertical	15m / 2drms *
GPS Antenna Connector	TNC
DGPS Accuracy	< 5m / 2drms
*) depends on SA	
GPS Solutions	
Beacon interoperability	
EGNOS interoperability	
WAAS interoperability	
OMNISTAR interoperability	
LongWave interoperability	
VHF interop. (DGPS over Msg.17)	
optional internal Beacon Receiver	
Combined GPS/DGPS Antenna	
Relay breaking capacity	
30V DC	8°
250V AC	8A
OPTIONAL INTERFACES	
Number of Data Ports RS232	up to 5
Bitrate	Up to 115000 bps
Simplex / Duplex	Duplex
Number of Data Ports IEC	1
61162-3 CAN (RS485)	
Bitrate	up to 1 Mbps

VHF RECEIVER	
Max. Useable Sensitivity	< -110dBm
Co-channel Rejection	> -8dB (25kHz); > -12dBm (12.5kHz)
Adjacent Channel Selectivity	> 70dB (25kHz); > 60dB (12.5kHz)
Inter-modulation Rejection	> 65dB
Spurious Response Rejection	> 70dB
Blocking	> 84dB
VHF MODEM	
Bitrate GMSK	9600 bps
RF Baud Rate (DSC)	1200bps
Modulation	GMSK / FSK

5 Setting-to-Work/Configuration

5.1 Setting-to-Work

The AIS Transponder Unit and antennas must be installed as described in Section 3.2.2, Page 6 (Step-by-Step Installation Procedure). For information about the dimensions see Section 4.2 (Technical Information). The cabling and connection must be performed corresponding to the Cabling Documents in Section 8. Depending on the system in which the AIS have to be integrated, the configuration has to be performed as described in section 5.3.1.

5.2 Software Version

For AIS systems with an MX420/MKD:

It must be verified that the MX420/MKD has the software version V2.0(841) or later. The software versions can be determined by means of the **AUX7** screen of the MX420.

5.3 Configuration

No adjustments have to be performed on the antennas. These components are ready for use.

The AIS Transponder Unit is configured using the MX420/MKD.

For information in detail, see the corresponding Technical Manuals and the Online Help of these systems.

The following descriptions are an aid for the configuration of the AIS Transponder.

NOTE:

The system from which the AIS Transponder Unit has been configured and the AIS itself must be restarted after any change in the configuration. Otherwise these modifications may have no effect.

The MX535 will maintain configuration data inside the transponder during power fails. In the event that the MX535 needs to be replaced, the configuration data from the MX420 must manually be resent to the MX535.

Master/Slave

After the power on from both units the MX420 (CDU) transmits the configuration data to the MX535 (Transponder). This is done with the SSD (ship static data) and the VSD (voyage ship data) sentences. The MX535 has an internal memory to store the data. The configuration data are valid until a new SSD or VSD is received. If the connection between the both units is lost, the MX535 operates with these stored data.

To send new data it is necessary to enter a password in the configuration menu from the MX420 (CDU).

The MX420 transmits the SSD and VSD after every restart.

5.3.1 Configuration with MX420/MKD

It is necessary to configure the MKD to work with the MX535 (NAUTICAST) Transponder. For more information refer to the Operation Manual of the MX420/MKD.

5.4 Testing

The Transponder Unit has neither traffic light indicators nor a display. Correct functioning cannot be made visible directly.

To test the interfaces of the ship's sensor inputs and the interface to the display unit, set the system in operation and view the own ship's (AIS1 Screen) data in the MKD. If the own ship AIS data are displayed, the interfaces are working properly.

The VHF Transceiver can only be tested if a second AIS system is within the range of the Transceiver. The signals of this AIS must be received and this second AIS must receive the signals of your own AIS.

6 Repair/Maintenance



GENERAL:

The jumper settings and switch settings on a replacement PCB must be the same as on the defective PCB. The wire connections must be made in exactly the same way. Exceptions are explained in this manual.

6.1 Trouble Shooting

6.1.1 Hints

In the case of problems during setting-to-work, the cabling should be checked again. All components must be supplied with 24 VDC power.

To get more information about the problem, read the system fault messages on the screen (MX420/MKD).

Test of the MX535 UAIS Transponder Output

- 1) Power down the system
- 2) Verify the connection of the MX420/MKD NMEA5 port to MX535 Channel 4 as shown in the picture below.

MX535 PORT CONNECTIONS

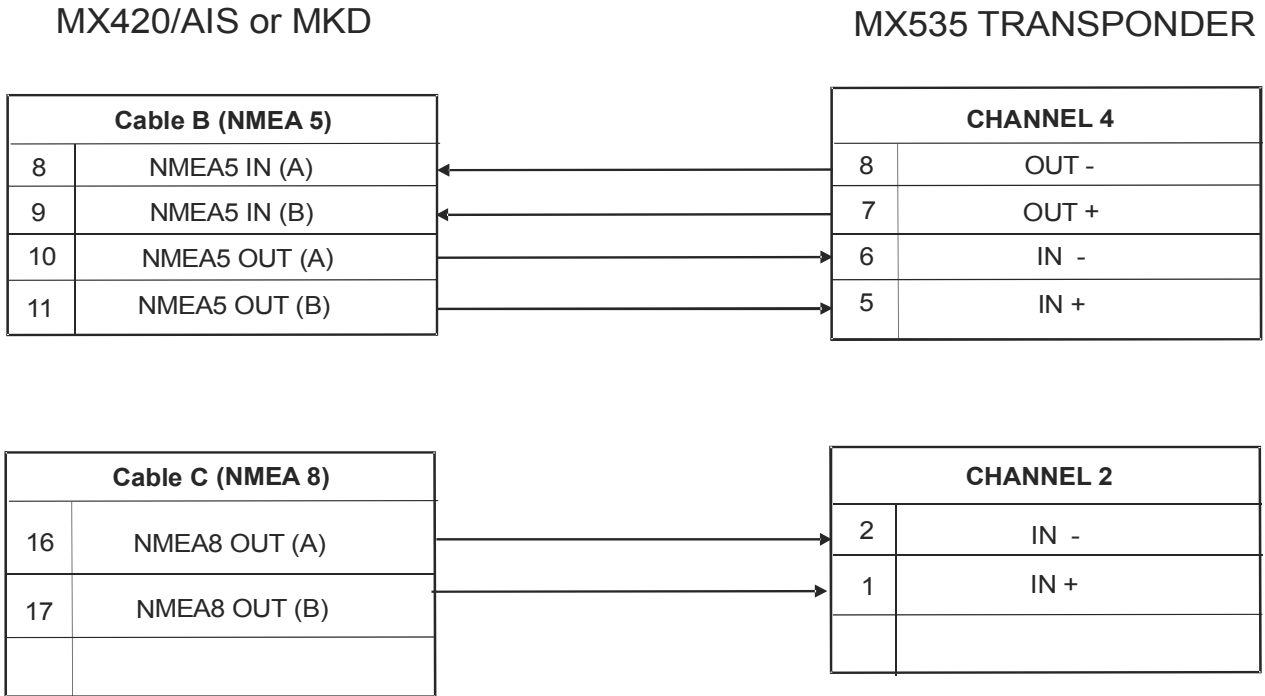

Figure 2.5 - Cable connection for the MX535 AIS to MX420/MKD

3. Power up the MKD and the MX535 transponder.
4. Configure the "Transponder Type" to NAUTICAST and the "Static Config Update" to MKD.
5. Activate the "AIS Connected (to Port 5)" to Yes under the AIS Static setup.
6. Using the built-in Input Monitoring tool of the MKD verify if the output of the MX535 transponder as shown below is being received on PORT 5 of the MKD. Refer to the MX420 Installation and Service Manual for the special procedure in "Viewing Input Data".

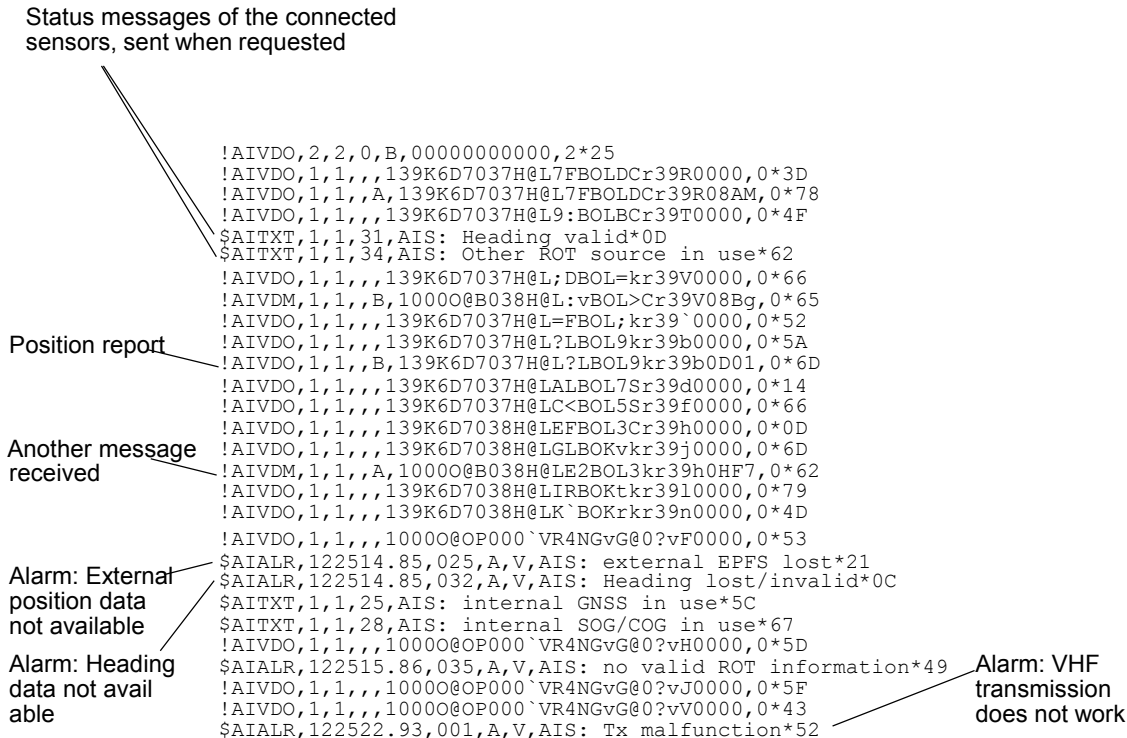

Figure 2.6 - Protocol AIS TxD

Figure 2.6 - Protocol AIS TxD shows the protocol, which has been transmitted by AIS. The alarm messages can be forced by disconnecting the sensors and/or the VHF antenna.

If there is no communication on the interface, the AIS is not working. If the power supply and the cable connection are correct, the AIS Transponder Unit may be defective.

NOTE:

If a ship's sensor is connected to the interface which has been used for the test, it must be made sure, that all modifications of the parameterisation of this interface that were necessary for the test are cancelled.

7 Fault Code List

The following fault codes (integrity alarm conditions) can be displayed at the MKD (AIS9 Screen).

Fault	Description Text	Cause/Source	Reaction of the System Remedy
001	AIS: Tx malfunction	VHF Antenna, cabling	Reaction: The Transponder Unit stops the transmission. Remedy: Check of the antenna and the antenna cabling (short circuit or missing contact at the connectors)
002	AIS: Antenna VSWR exceeds limit (VSWR = Voltage Standing Wave Ratio)	VHF antenna, installation	Reaction: The Transponder Unit continues operation. Remedy: Check of the antenna and the antenna cabling (75 Ω cable instead of 50 Ω cable)
003	AIS: Rx channel 1 malfunction	Internal error	Reaction: The Transponder Unit stops the transmission on the affected channel. Remedy: The Transponder Unit must be exchanged.
004	AIS: Rx channel 2 malfunction		
005	AIS: Rx channel 70 malfunction		
006	AIS: General failure	Internal error	Reaction: The Transponder Unit stops the transmission. Remedy: The Transponder Unit must be exchanged.
008	AIS: MKD connection lost (MKD = Minimum Keyboard Display)	No Operating/Display Unit connected	Reaction: The Transponder Unit continues operation. Remedy: The Display Unit does not communicate with the Transponder Unit. Check the cabling/connection of the Primary Display Port. Check if the Display Unit is working.
025	AIS: External EPFS lost (EPFS = Electronic Position Fixing System such as GPS)	No valid position data at interface S1, S2, S3	Reaction: The Transponder Unit continues operation with the position data of the internal position sensor. If there is no valid position data available from the internal position sensor, additionally error 026 is displayed. Remedy: The telegrams GLL, GNS, GGA, RMC can not be received. Check the sensor and the cabling; Check if the system that delivers the data is working; Check the baud rate settings of the sensor inputs.
026	AIS: No sensor position in use	No valid position from internal position sensor	Reaction: The Transponder Unit continues operation. Remedy: Check the cabling and the antenna of the internal GPS sensor.

029	AIS: No valid SOG information	No data from external sensor and from internal position sensor	Reaction: The Transponder Unit continues operation. Remedy: The telegrams VBW, VTG, RMC can not be received. Check the sensor and the cabling; Check if the system that transmits the data is working; Check the baud rate settings of the sensor inputs.
030	AIS: No valid COG information	No data from external sensor and from internal position sensor	Reaction: The Transponder Unit continues operation. Remedy: The telegrams VTG, RMC can not be received. Check the sensor and the cabling; Check if the system that transmits the data is working; Check the baud rate settings of the sensor inputs.
032	AIS: Heading lost/invalid	No data from external sensor	Reaction: The Transponder Unit continues operation. Remedy: The telegrams HDT can not be received. Check the sensor and the cabling; Check if the system that transmits the data is; Check the baud rate settings of the sensor inputs.
035	AIS: No valid ROT information	No data from external sensor	Reaction: The Transponder Unit continues operation. Remedy: The telegrams ROT can not be received. Check the sensor and the cabling; Check if the system that transmits the data is; Check the baud rate settings of the sensor inputs.
051	AIS: Channel management information not accepted	E.g. overlapping with an existing area	Reaction: The Transponder Unit continues operation. Remedy: Check the channel management information.
052	AIS: GPS receiver fault		Reaction: The Transponder Unit continues operation without internal GPS data and without direct GPS time synchronization. Remedy: The Transponder Unit must be exchanged.
0204	AIS: offline	No connection between CDU and Transponder Unit	Reaction: The Transponder Unit continues operation. Remedy: The cabling must be checked.

8 Cabling Documents

Grounding

Grounding connection is important for EMC purposes as well as for protecting people's lives.

Regardless of the type of ship's grounding (e.g. star pattern or ground plane pattern), no potential difference should be measurable between two different ground connectors. Potential differences cause compensation currents on the cable shields. If the ship's hull is a non-metallic structure, all metallic parts in contact with the water form an artificial ground.

All ground connections should be as short as possible. If possible, different units should be connected to individual ground connectors. Whenever possible, metallic housings should be screwed or welded directly to the ship's metallic structure. If a safe grounding contact is not ensured, additional conductors are necessary. Furthermore, all ground connections should have a low RF-impedance, and should be resistant against vibration and corrosion. Grounding conductors on an open-air deck must be made of corrosion-protected steel, and inside the ship they must be made of copper.

The grounding should be done in such a way that the connection could be inspected in a convenient manner.

EMC Purposes

Connect only the shields of cables that are indicated in the wiring instructions. As rule of thumb, the shield of any transmit wire get grounded at the transmitting source.

Protective Ground

All removable metallic parts of the housings are grounded by means of separate, flexible cables to the main structure of the housing. It is important to connect this ground-cable after parts have been dismantled or exchanged.

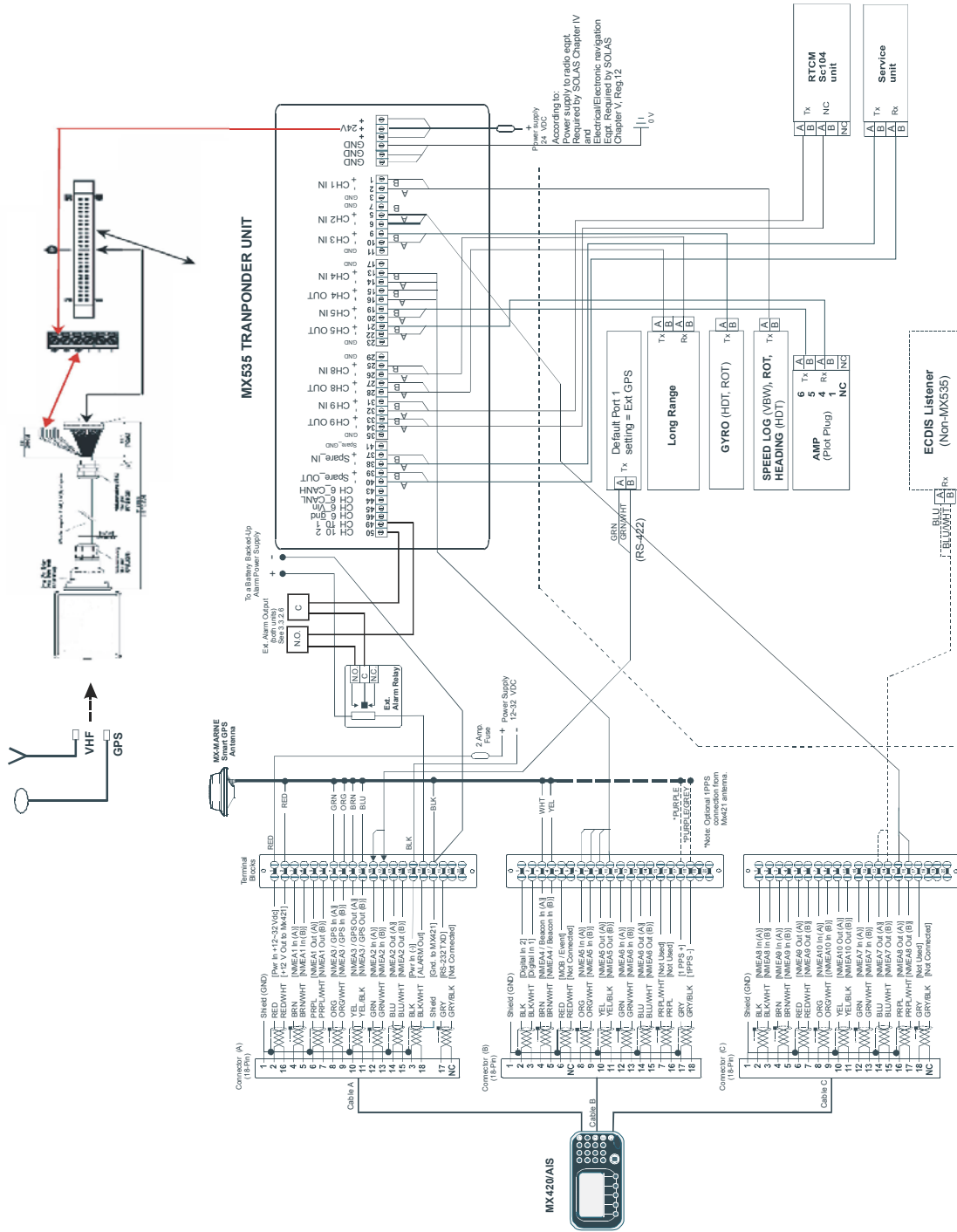

Figure 2.6 - Wiring Diagram, MX535 Transponder System with MX420/AIS or MKD

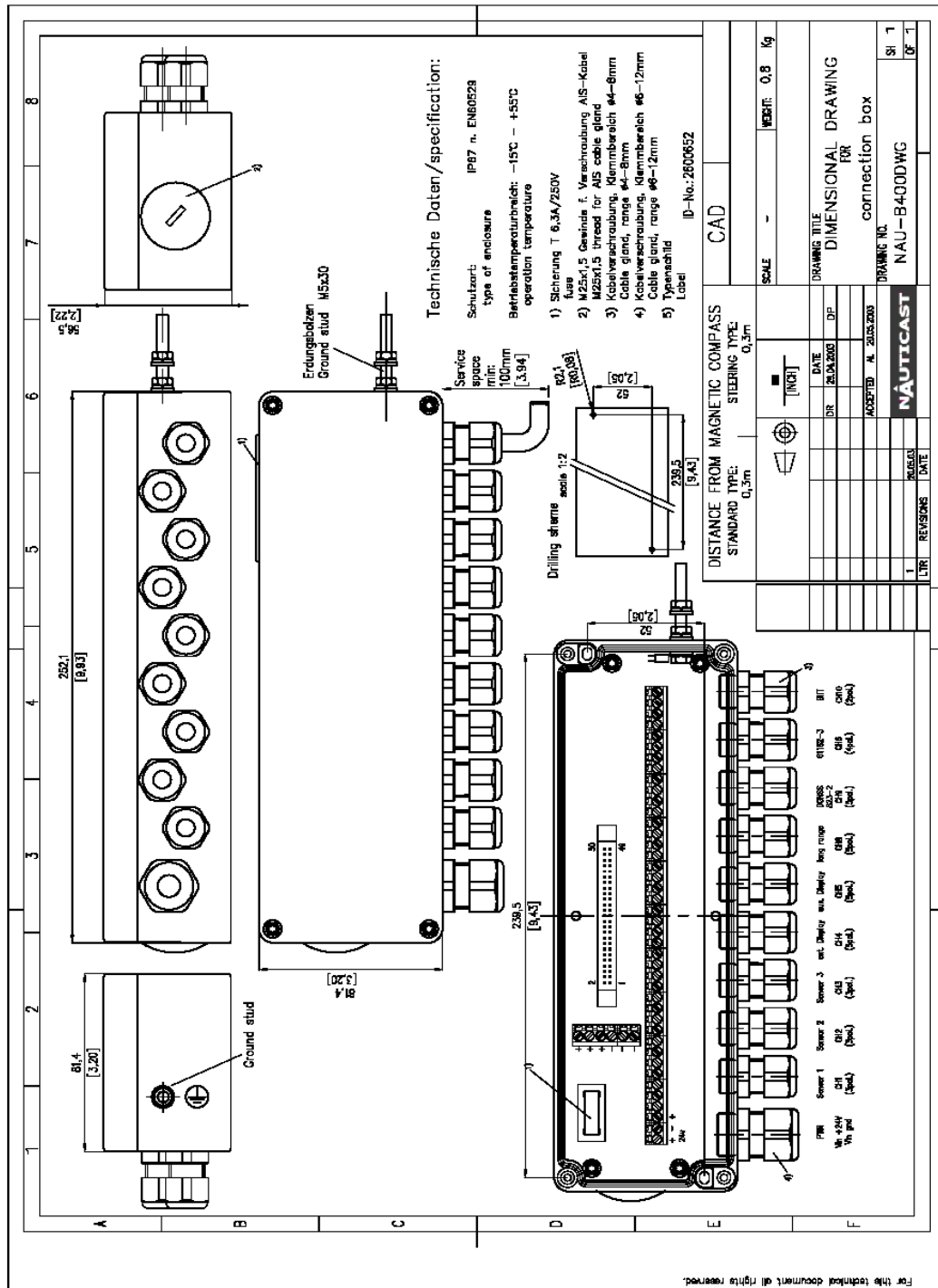

Figure 2.8 – Dimensional Drawing for Connection Box

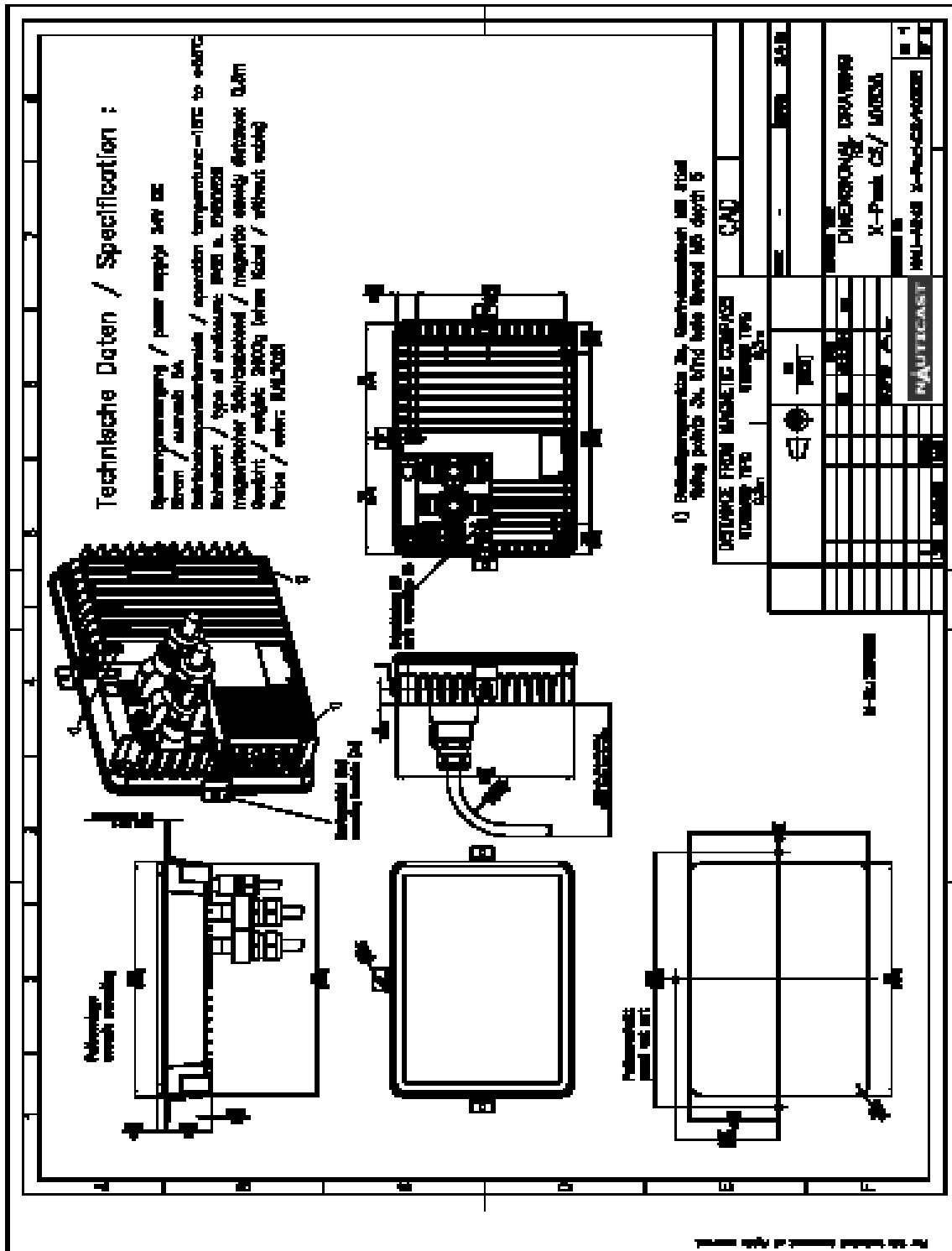

Figure 3.0 – Dimensional Drawing for MX535

MX535 UAIS Transponder Unit

Technical & Installation Manual

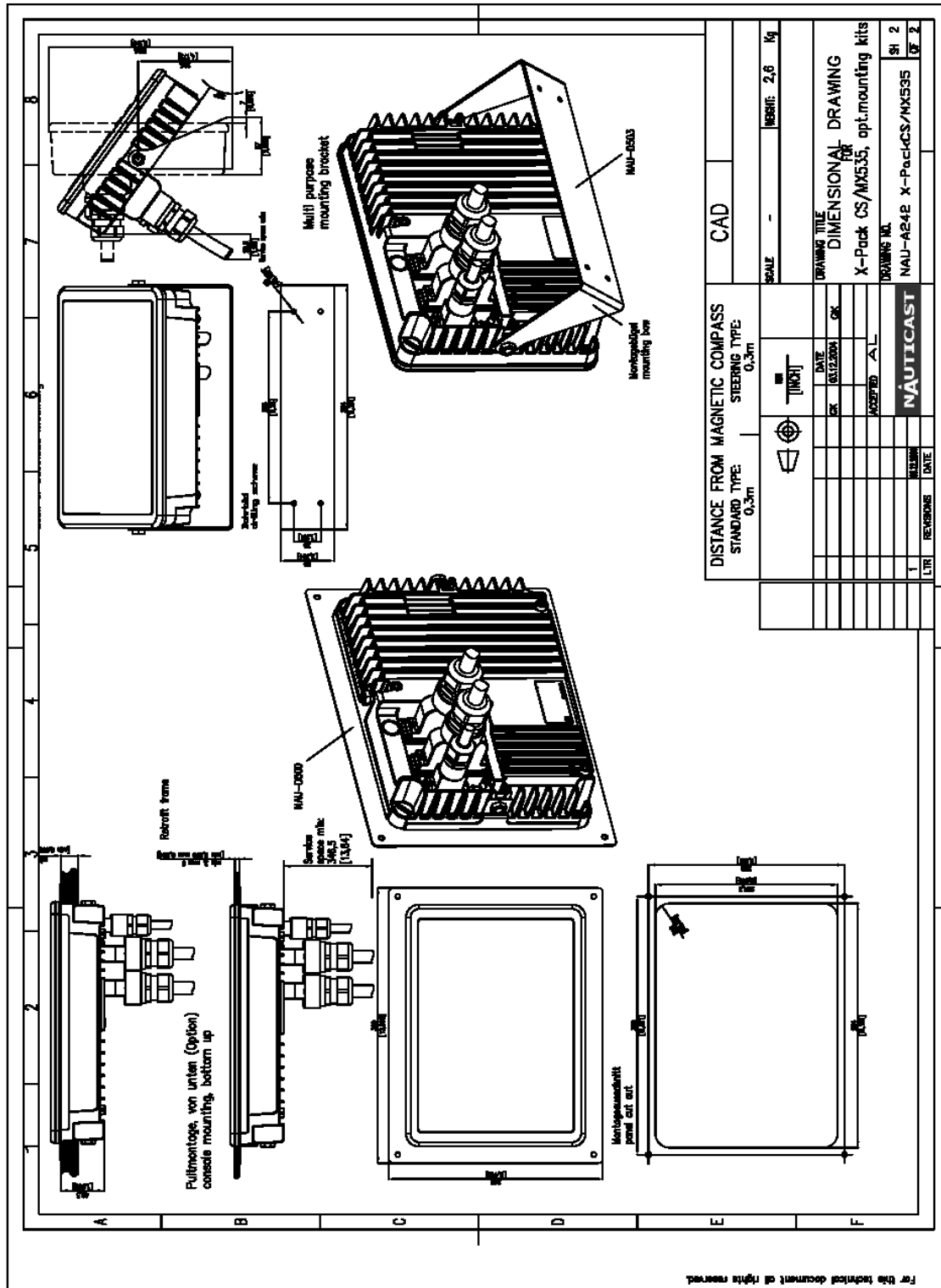

Figure 3.1 – Dimensional Drawing for MX535, opt. Mounting Kits

PRODUCT WARRANTY AND LIMITATION OF LIABILITY

This product is warranted by MX-Marine (the "Seller") to original purchaser (the "buyer") for use only to be free of all defects in material and workmanship for a period of twelve (12) months from date of purchase by Buyer.

If during the warranty period, this product or parts thereof ("Product") are found to be defective in material or workmanship, Seller shall repair or replace the defective Product, at the discretion of the Seller.

In order to claim this warranty service, Buyer shall return the defective Product, together with proof of purchase to Seller or its authorized service representative and pay all transportation charges, duties, and taxes associated with the return of the Product to Seller. Seller shall reimburse Buyer for costs of the return to Buyer of Product found to be defective and covered by this warranty. Product which is repaired or replaced under the warranty is covered by this warranty for the remainder of the original warranty period or for a period of ninety (90) days after return shipment to Buyer, whichever is longer.

SELLER'S MAXIMUM LIABILITY ARISING FROM USE OF SELLER'S PRODUCT SHALL NOT EXCEED AND BUYER'S REMEDY IS LIMITED IN ANY EVENT TO REPAIR OR REPLACEMENT AND REIMBURSEMENT FOR COSTS ASSOCIATED WITH THE RETURN OF THE DEFECTIVE PRODUCT AS PROVIDED HEREIN; AND SUCH REMEDY SHALL BE THE BUYER'S ENTIRE AND EXCLUSIVE REMEDY.

This warranty does not apply to failure of any equipment not sold to Buyer by Seller, or to any Product which has been subjected to misuse, lightning, an accident, or improper installation, maintenance or application, nor does it extend to any Product which has been repaired or altered by anybody other than the Seller or its authorized service representative, unless such repair or alteration was authorized in writing by Seller. This warranty also does not apply to batteries and losses or damage due to the batteries. Since the GPS system on which the Product operates is furnished by the U.S. Government, not Seller, the Seller shall not be responsible for the GPS system or changes in the GPS System availability, coverage or accuracy.

THIS PRINTED LIMITED WARRANTY IS ACCEPTED BY BUYER IN LIEU OF ANY OTHER WARRANTY FOR THE PRODUCT, WHETHER EXPRESSED OR IMPLIED, INCLUDING, WITHOUT LIMITATION, ANY IMPLIED WARRANTY OF MERCHANTABILITY OR FITNESS FOR A PARTICULAR PURPOSE.

IN NO EVENT SHALL SELLER BE LIABLE FOR INCIDENTAL OR CONSEQUENTIAL DAMAGES OF ANY KIND OR NATURE, INCLUDING, BUT NOT LIMITED TO LOSS OF PROFIT OR REVENUE, COMMERCIAL LOSS, DAMAGE TO OR LOSS OF PROPERTY, ARISING FROM OR RELATED TO THE USE OF THE PRODUCT.

THIS PRODUCT IS AN AID TO NAVIGATION ONLY. UNDER NO CIRCUMSTANCES SHOULD IT BE USED IN LIEU OF AUTHORIZED GOVERNMENT CHARTS. ITS ACCURACY CAN BE AFFECTED BY MANY FACTORS SUCH AS EQUIPMENT.





*MX-Marine (USA)
23868 Hawthorne Blvd., Suite 201
Torrance, CA 90505
USA*

*+1 310 791 8213 (Telephone)
+1 310 791 6108 (Fax)*

*MX-Marine (UK)
Ocean Quay
Southampton SO14 5QY
United Kingdom*

*+44(2380) 33 99 22 (Telephone)
+44(2380) 33 03 45 (Fax)*

Internet: www.mx-marine.com