



LED ANCHOR/MASTHEAD LIGHT

12-VOLT: 7800 Series

SAVE THESE INSTRUCTIONS

Form Number 69438 Rev. A

08-04

FEATURES

Attwood 3-mile (4.8 km) Anchor/Masthead Lights consist of anodized aluminum poles with lightweight heads. Horizontal base allows light pole to be adjusted and locked within a 180° arc.

Lights provide a 3-mile, 225° forward running light and 2-mile all-round anchor light. For power-driven boats up to 65.6 feet (20 meters). Lights meet USCG CFR 183.810, ABYC A-16 requirements, and all applicable standards as tested by Imama Laboratory, Inc., December 3, 2007.

CAUTION

To prevent personal injury, disconnect the power source when installing or servicing any electrical product. Remove vessel from water when using any 120 VAC power tools.

REQUIRED FOR INSTALLATION

- Cordless drill; 1/8" and 3/8" (3 and 10mm) bits
- Marine-grade non-silicone sealant
- Phillips screwdriver
- Two #10 stainless steel counter sunk screws
- 3-position switch (OFF/ON/ON)
- Fuse holder and fuse: 1-amp (for 12-volt systems)
- 16-gauge wire
- Marine-grade wire connectors for 16-gauge wire

MOUNTING LOCATION

CAUTION

Install light so that logo stamped in the metal plate is TOWARD BOW and aligned on the fore/aft centerline of the vessel (within 1°). If not properly aligned, lights will not shine in required fore/aft arc. (Figure 2)

Base must pivot on the fore/aft centerline and be mounted on a surface that allows a 360° arc of unobstructed light visibility. (Figure 1)

INSTALL LIGHT

1. Loosen knob and adjust light to vertical position. (Figure 2)
 2. Place light in selected position.
 3. Use adaptors, if necessary, to allow installation on angled windshields.
 4. Using the base as a template, mark the two mounting hole locations and one wire access hole. (Figure 3)
- CAUTION**
Position wire access hole carefully, especially on aluminum boats, so that wires do not contact the hull.
5. Remove light. Drill two 1/8" (3mm) pilot holes for #10 screws. Drill one 3/8" (10mm) wire access hole.
 6. Bring two 16-gauge (+) wires and one 16-gauge (-) wire up through access hole. DO NOT connect power to switch until you read CONNECT POWER TO SWITCH.
 7. Use marine-grade waterproof crimp connectors to connect blue wire to one (+) positive lead from 3-position switch; connect gray wire to second (+) lead. Connect (-) negative source to black wire and route to (-) negative terminal on battery.
 8. Fasten light to deck with two #10 stainless steel counter sunk screws. DO NOT OVERTIGHTEN.

CONNECT POWER TO SWITCH

Use ONLY the rated voltage. Higher voltage can damage light and void product warranty. All positive (+) wires must be protected by fuse (1-amp for 12-volt).

1. Use 3-position, double-pole OFF/ON/ON switch. (Figure 4)
2. Masthead (running) Lights: Gray (power +) wire should be connected to the switch so it can be powered independent from the anchor light. This switch position can also be wired to control other running lights i.e. bow, stern lights. (Figure 5)
3. Anchoring (All-Round) Lights: Blue (power +) wire should be connected to the switch so both Masthead (running) lights and anchor light are powered at the same time. (Figure 5)
4. Test forward running and anchor lights for proper operation.

ATTWOOD LIMITED 10-YEAR WARRANTY

Because of the longevity of Attwood's LED lighting technology, Attwood offers a limited 10-year warranty on this LED lighting product. See Product Catalog or attwoodmarine.com for details.

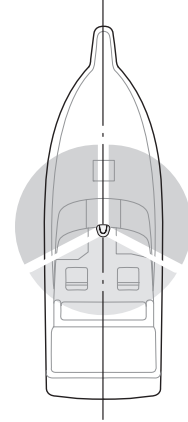

Figure 1
Figure 1
Abbildung 1
Figure 1

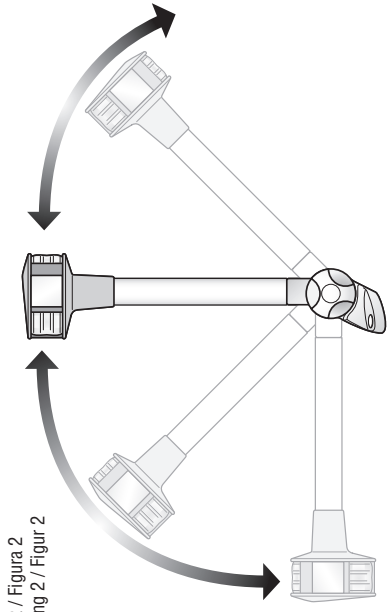

Figure 2 / Figura 2
Abbildung 2 / Figur 2

Figure 2

- A. Forward
- B. Aft

Figure 2

- A. Delantero
- B. Popa

Figure 2

- A. framåt
- B. bakåt

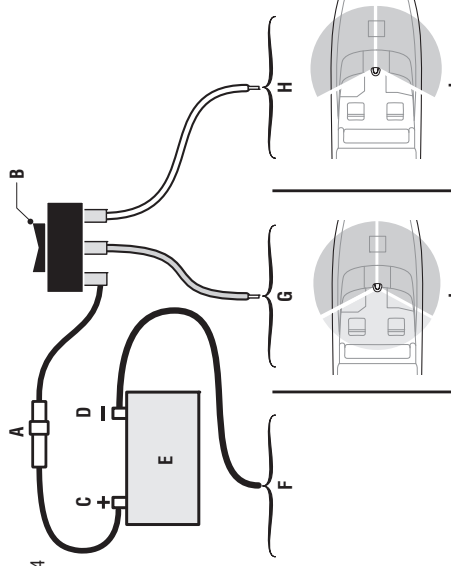

Figure 4 / Figura 4
Abbildung 4 / Figur 4

Figure 4

- A. 2-Amp Fuse
- B. 3-Position Switch (OFF/ON/ON)
- C. positif
- D. négatif
- E. 12V DC
- F. Black (To Negative)
- G. Blue (Positive-1)
- H. Gray (Positive-2)
- I. Anchor Lights (All Around)
- J. Masthead Lights (Running)

Figure 4

- A. Fusible de 2 ampères
- B. Interrupteur à trois positions (arrêt/marche/marche)
- C. positif
- D. négatif
- E. 12 volts CC
- F. Noir (vers négatif)
- G. Bleu (pos. - 1)
- H. Gris (pos. - 2)
- I. Feux de mouillage (visibles sur tout l'horizon)
- J. Feux de tête de mât (navigation)

Figure 4

- A. 2 A säkring
- B. 3-vägs strömbrytare (AV/PÅ/PÅ)
- C. positiv
- D. negativ
- E. 12V DC
- F. svart (till negativ)
- G. blå (pos. -1)
- H. grå (pos. -2)
- I. ankarlampor (rundstrålande)
- J. masttopplampor (gångljus)

Figure 5 / Figura 5
Abbildung 5 / Figur 5

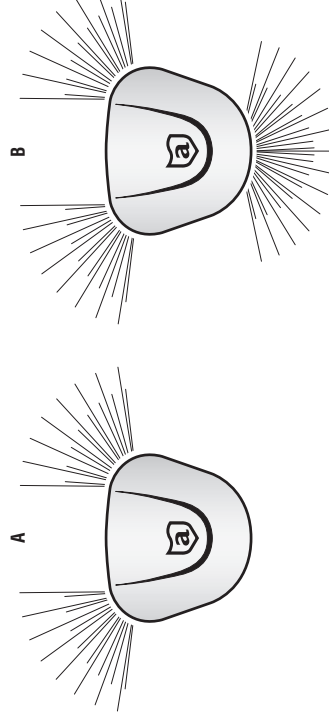

Figure 5

- A. Masthead Lights (Running)
- B. Anchor Lights (All Around)

Figure 5

- A. Luces de ancla (giratorias)
- B. Luces de tope de palo (en funcionamiento)

Figure 5

- A. ankarlampor (rundstrålande)
- B. masttopplampor (gångljus)

Figure 3

- A. Vis à tête fraisée plate n° 10 en acier inoxydable
- B. Trou d'accès des fils de 10 mm
- C. Avant-trou de 3 mm
- D. Fil noir à la masse
- E. Fil gris feu de mât (avant)
- F. Fil bleu feu de mouillage (arrière)

Figure 3

- A. #10 Counter Sunk Screw
- B. 3/8" (10mm) Wire Access Hole
- C. 1/8" (3mm) Pilot Hole
- D. Black Wire to Ground
- E. Grey Wire Mast Light (Forward)
- F. Blue Wire Anchor Light (Aft)

Figure 3

- A. skruv (nr 10) med försänkt huvud
- B. 10 mm kabelhål
- C. 3 mm styrlhål
- D. svart kabel till jord
- E. grå kabel mastljus (framåt)
- F. blå kabel ankarljus (bakåt)

