

DOCUMENT 1025
REVISION B
July 14, 2011



Instruction Manual



Airside Guidance Sign AGS-LED
858 LED Series
Sizes 1, 2, 3, 4 and 5

Cooper Industries
Crouse-Hinds Division
Airport Lighting Products
1200 Kennedy Road
Windsor, CT 06095

Copyright © 2011 Cooper Technologies Company

For Parts or Technical Service Call (860) 683-4300

Instruction Manual
AGS-LED
858 LED Series
Sizes 1, 2, 3, 4 and 5**1 Revisions**

Revision Number	Issue/Reissue Number Letter	Description	Checked	Approved
A	A211-188	Initial Release of AGS-LED 858 Sign Manual	MEG	6/8/11
B	A211-218	Update to reflect new single conductor wiring	SD	7/14/11

Instruction Manual
AGS-LED
858 LED Series
Sizes 1, 2, 3, 4 and 5**2 Limited Product Warranty**

THE FOLLOWING WARRANTY IS EXCLUSIVE AND IN LIEU OF ALL OTHER WARRANTIES, WHETHER EXPRESS, IMPLIED OR STATUTORY, INCLUDING, BUT NOT BY WAY OF LIMITATION, ANY WARRANTY OF MERCHANTABILITY OR FITNESS FOR ANY PARTICULAR PURPOSE.

Crouse-Hinds Airport Lighting Products (the “Company”) warrants to each original Buyer of Products manufactured by the Company that such Products are, at the time of delivery to the Buyer, free of material and workmanship defects, provided that no warranty is made with respect to:

Any Product which has been repaired or altered in such a way, in Company’s judgment, as to affect the Product adversely;

Any Product which has, in Company’s judgment, been subject to negligence, accident or improper storage;

Any Product which has not been operated and maintained in accordance with normal practice and in conformity with recommendations and published specification of Company; and,

Any Products, component parts or accessories manufactured by others but supplied by Company (any claims should be submitted directly to the manufacturer thereof).

Crouse-Hinds Airport Lighting Products’ obligation under this warranty is limited to use of reasonable efforts to repair or, at its option, replace, during normal business hours, at any authorized service facility of Company, any Products which in its judgment proved not to be as warranted within the applicable warranty period. All costs of transportation of Products claimed not to be as warranted and of repaired or replacement Products to or from such service facility shall be borne by Purchaser. Company may require the return of any Product claimed not to be as warranted to one of its facilities as designed by Company, transportation prepaid by Purchaser, to establish a claim under this warranty. The cost of labor for installing a repaired or replacement product shall be borne by Purchaser. Replacement parts provided under the terms of this warranty are warranted for the remainder of the warranty period of the Products upon which they are installed to the same extent as if such parts were original components thereof. Warranty services provided under the Agreement does not assure uninterrupted operations of Products; Company does not assume any liability for damages caused by any delays involving warranty service. The warranty period for the Products is 24 months from date of shipment or 12 months from date of first use whichever occurs first.

Instruction Manual
AGS-LED
858 LED Series
Sizes 1, 2, 3, 4 and 5

3 Safety Notices

This equipment is normally used or connected to circuits that may employ voltages which are dangerous and may be fatal if accidentally contacted by operating or maintenance personnel. Extreme caution should be exercised when working with this equipment. While practical safety precautions have been incorporated in this equipment, the following rules must be strictly observed:

3.1 Keep Away from Live Circuits

Operating and maintenance personnel must at all times observe all safety regulations. Do not perform maintenance on internal components or service with power ON.



WARNING

WARNING:

DO NOT PERFORM MAINTENANCE ON INTERNAL COMPONENTS OR SERVICE WITH POWER ON.

3.2 RESUSCITATION

Maintenance personnel should familiarize themselves with the technique for resuscitation found in widely published manuals of first aid instruction.

4 Safety Symbols

4.1 Danger



DANGER

DANGER:

The hazard or unsafe practice will result in severe injury or death.

4.2 Warning



WARNING

WARNING:

The hazard or unsafe practice could result in severe injury or death.

4.3 Caution



CAUTION

CAUTION:

The hazard or unsafe practice could result in minor injury.

4.4 Warning: Notice



NOTICE

WARNING:

Possibly dangerous situation, goods might be damaged.

4.5 Warning : Important



IMPORTANT

WARNING:

Helpful information.

Instruction Manual
AGS-LED
858 LED Series
Sizes 1, 2, 3, 4 and 5**5 Test Equipment and Tools**

There is a wide variety of tools and equipment needed to safely and correctly perform airfield lighting equipment installation and maintenance. In addition to the obvious tools (screwdrivers, wrenches, etc.), there is a specialized equipment needed to do the job.

Multimeter

One of the most important pieces of test equipment is the Multimeter. It is used to measure voltages, currents, and resistances. Almost every single maintenance task requires the use of a multimeter at one point or another. A quality meter in good repair and calibration is a must because airfield lighting power distribution equipment produces non-sinusoidal waveforms, traditional average reading meters are inaccurate and have very limited use. Checking or adjusting equipment based upon incorrect current reading may dramatically reduce lamp life and adversely affect power equipment performance. A meter with TRUE RMS measuring capability and a current clamp-on probe is needed to accurately measure distorted or chopped waveforms. All meter manufacturers offer TRUE RMS measuring meters. The following is a short list of TRUE RMS Multimeters from Fluke:

Manufacturer	Model Number
Fluke	87V, 287

Our recommended meter is the Fluke 87V with the Fluke I800 current clamp.

Refer to the equipment manufacturer's manuals for the proper use, maintenance and calibration (if necessary) of all meters.

Instruction Manual
AGS-LED
858 LED Series
Sizes 1, 2, 3, 4 and 5

6 Table of Contents

1	Revisions	ii
2	Limited Product Warranty	iii
3	Safety Notices	iv
3.1	Keep Away from Live Circuits	iv
3.2	RESUSCITATION	iv
4	Safety Symbols	v
4.1	Danger	v
4.2	Warning	v
4.3	Caution	v
4.4	Warning: Notice	v
4.5	Warning : Important	v
5	Test Equipment and Tools	vi
6	Table of Contents	vii
7	List of Figures and Tables	viii
8	General Information	1
8.1	General Description	1
8.2	Classification of Signs	1
8.3	Part Numbers:	2
9	Installation	3
10	Maintenance and Troubleshooting	6
10.1	General	6
10.2	Problem Solving Guide	7
10.3	Measuring Input Current (Signs Without Optional Power Switch)	10
10.4	Measuring Input Current (Signs With Optional Power Switch)	10
10.5	Checking Power Supply LED Cable	11
10.6	Checking LED MODULE Cable Connections	12
10.7	Checking the First LED MODULE	12
10.8	Checking the Second LED MODULE	13
10.9	Continue Checking the Rest of the LED MODULES	14
10.10	Replacing an LED MODULE	15
10.11	Sign PC Board P/N 62277 Calibration	17
10.12	Replacing Sign Power Supply Board & Heat Sink P/N 62277	17
11	Figures and Tables	20

Instruction Manual
AGS-LED
858 LED Series
Sizes 1, 2, 3, 4 and 5**7 List of Figures and Tables**

Figure 1. Single module sign	20
Figure 2. Double module sign.....	21
Figure 3. Three module sign	22
Figure 4. Four module sign.....	23
Figure 5. Distance Marker	24
Figure 6. Sign Options	25
Figure 7. Heat Sink/LED Assembly showing wiring input and output connections	26
Figure 8. LED Array Wiring, One Module Signs.....	27
Figure 9. LED Array Wiring, Two Module Signs	28
Figure 10. LED Array Wiring, Three Module Signs	29
Figure 10. LED Array Wiring, Four Module Signs.....	30
Figure 11. LED Array Wiring, Distance Marker.....	31
Figure 12. Recommended Transformer Housing Location & Concrete Foundation/Pad Details	32
Figure 12a. Expanded left section of Figure 12.....	33
Figure 12b. Expanded right section of Figure 12	34
Figure 12c. Expanded top section of Figure 12	35
Figure 14. Concrete Foundation/Pad configurations, Sizes 2.....	37
Figure 15. Concrete Foundation/Pad configurations: Two 4-Module Signs, Side by Side	38
Figure 16. Sizes 3, & 5 Concrete Foundation/Pad Configurations.....	39
Figure 18. Power Supply Box.....	41
Figure 21. Power Supply Wiring Diagram	42
Figure 22. Checking the Power Supply Output Voltage After Turn-Off.....	43
Table 1. Power Supply Switch and Jumper Selection (FERRO CCR).....	44
Table 2. Power Supply Switch and Jumper Selection (SERIES CCR)	45
Table 3. AGS 858 LED Sign Style 2 VA Load & Matching Isolation Transformer (Ferro).....	46
Table 4. AGS 858 LED Sign Style 3 VA Load & Matching Isolation Transformer (Ferro).....	47
Table 5. AGS 858 LED Sign Style 5 VA Load & Matching Isolation Transformer (Ferro).....	48
Table 6. AGS 858 LED Sign Style 2 VA Load & Matching Isolation Transformer (Series)	49
Table 7. AGS 858 LED Sign Style 3 VA Load & Matching Isolation Transformer (Series)	50
Table 8. AGS 858 LED Sign Style 5 VA Load & Matching Isolation Transformer (Series)	51
Table 9. Style 2 - Three step regulator currents.....	52
Table 10. Style 3 - Five step regulator currents	52
Table 11. Style 5 – Fixed regulator current	52
Table 12. Power Supply Faults	53
Table 13. Parts List	54
Table 14. Estimated max sustained force on the sign body (Does not include safety margin) ...	55

Instruction Manual
AGS-LED
858 LED Series
Sizes 1, 2, 3, 4 and 5**8 General Information****8.1 General Description**

Crouse-Hinds Airport Lighting Products, “AIRSIDE” internally illuminated LED Taxiway and Runway Signs provide outstanding message visibility, day or night. White on Red and Yellow on Black and Black on Yellow color combinations may be ordered with any desired message. Signs are available as single or double faced and are provided with retro-reflective sign face. For further information on Taxiway Signs and their use, consult the latest revision FAA Advisory Circulars AC 150/5220-9, AC 150/5340-18, and AC 150/5345-44.

8.2 Classification of Signs

The signs covered in this manual are designed and manufactured in accordance with the requirements of FAA Advisory Circular AC 150/5345-44J. Specifications for Taxiway and Runway Signs and conform to the following classifications as indicated in paragraph 1.2 of the above Advisory.

Type L-858Y – Direction destination and boundary sign – black legend on a yellow background.

Type L-858R – Mandatory instruction sign white legend on a red background.

Type L-858L – Taxiway and runway location sign yellow legend and border on a black background.

Type L-858B –Runway Distance Remaining sign with a white legend on a black background.

Type L858C – Taxiway Ending Marker sign yellow strips on black background (2 module sign only)

A sign may consist of multiple arrays of the above messages.

NOTE: Size 5 information in this manual is the same as the Size 3 single module unless noted otherwise.

P/N	Sizes
858S5-1X-X-X-X-XX	Size 1 – 12 inch legend (small body)
858S5-2X-X-X-X-XX	Size 2 – 15 inch legend (mid-size body)
858S5-3X-X-X-X-XX	Size 3 – 18 inch legend (large body)
858S5-4X-X-X-X-XX	Size 4 – 40 inch legend (large body DMS numerals and AGM symbol)
858S5-5X-X-X-X-XX	Size 5 – 25 inch legend (large body DMS numerals only)

CAT. # FAA Styles

-3 Style 2 – For operation from a 3 step series lighting circuit (4.8 to 6.6 amperes)

-5 Style 3 – For operation from a 5 step series lighting circuit (2.8 to 6.6 amperes)

-1 Style 5 – A (fixed) 5.5 ampere series lighting circuit

Class 2 – For operation from -40°C to +55°C (+131°F)

Mode 2 – Sign for use in areas subjected to wind speed of up to 200 mph (322 km/h)

Instruction Manual
AGS-LED
858 LED Series
Sizes 1, 2, 3, 4 and 5

8.3 Part Numbers:

PART NUMBER EXPLANATION

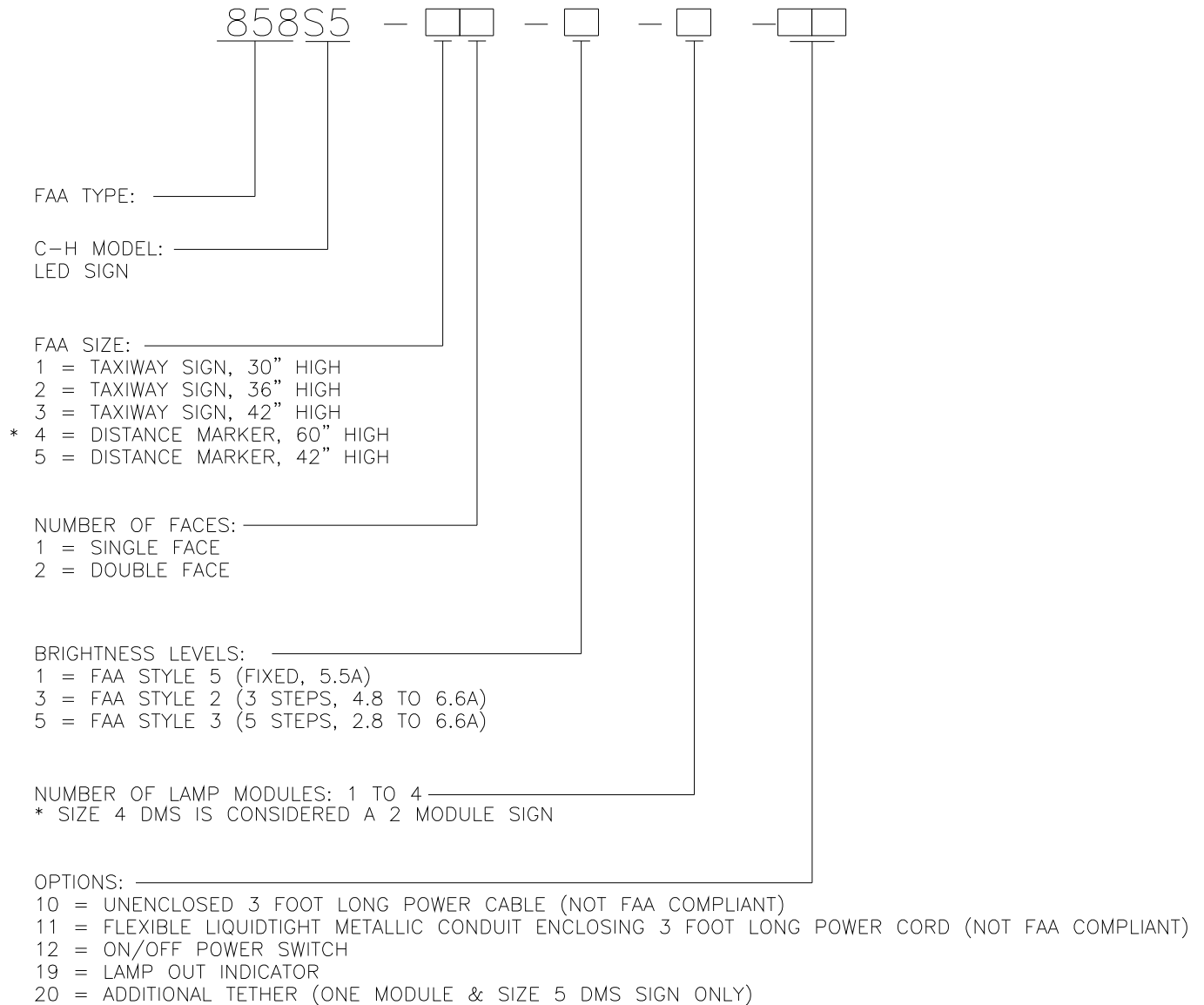

Instruction Manual
AGS-LED
858 LED Series
Sizes 1, 2, 3, 4 and 5**9 Installation****NOTICE****WARNING:**

Sign foundations/pad and their design are the responsibility of the installer and/or airport and recommendations/suggestions herein are for guidance only. Transformer housing and baseplates and/or covers, series isolation transformers, primary connector kits, series isolation transformer secondary cable extender, series isolation consolidating harness (if required), heat shrink kits, grounding rods, ground wire and connectors, floor flange anchor bolts and hardware are not included as part of the sign. Underlined items may be ordered from Crouse-Hinds Airport Lighting.

- a. Refer to FAA AC 150-5345-18F section 14 for Taxiway Guidance Sign location and for the perpendicular distance from the defined pavement edge to the near side of the sign. Similarly, see section 25 of FAA AC 150-5345-18F for Runway Distance Remaining Sign location and perpendicular distance from the defined pavement edge to the near side of the sign.

**IMPORTANT****WARNING:**

FAA specifications and Engineering Briefs may be obtained by searching the FAA web site: www.faa.gov.

- b. See Figures 12-17 for suggested concrete foundation/pad. Concrete foundations/pads should be of adequate mass, reinforcement, and psi strength rating for the maximum sustained force on the sign body and floor flange anchors must endure at its maximum plus a safety margin. The concrete foundation/pad should be installed in soil conditions that will help facilitate drainage and foundation/pad support. The floor flange anchor bolt material should also meet the maximum sustained force on the sign body plus a safety margin and must be ½ inch in diameter for use with the 25684-1 Floor Flange. See Table 14 for estimated maximum sustained force on the sign body.
- c. Concrete foundations/pads should extend at least 12 inches below the local frost line. Contact your local or regional building inspector if the depth is unknown for your area. The foundation/pad should extend at least 1 foot beyond the sign body to minimize damage from mowers.

Instruction Manual
AGS-LED
858 LED Series
Sizes 1, 2, 3, 4 and 5

- d. The concrete foundation/pad should be not more than 1 inch above grade in order to maintain the 3 inch maximum overall height above grade to the point of frangibility per FAA Engineering Brief no. 79. See the Engineering Brief for acceptable grading around the foundation/pad. The foundation/pad pad must be level.
- e. It is recommended that the contractor who is to install the concrete foundation/pad use cast in place anchor bolts. The threaded portion of the anchor bolts should be 1-5/8 inches minimum to 1-7/8 maximum above the top of the concrete foundation/pad (See Figures 12, 12a-12c). This requires that the anchor bolts be installed accurately as shown in the concrete foundation/pad dimensions Figure 13. The clearance holes on the floor flange are 5/8 inch diameter on a 4.75 inch diameter bolt circle for use with 1/2 inch anchor bolts.
- f. The concrete foundation/pad should include the series isolation transformer housing. It is recommended that this housing **not be** placed under the sign power leg to allow access to the series isolation transformer and connections for ease of troubleshooting and servicing (See Figures 12, 12a-12c). This housing would be on the side closest to the Taxiway or Runway. A 2 inch conduit elbow with threaded coupling attached at sign end would exit from the transformer housing side to the foundation/pad and be flush with the with the top of the concrete foundation/pad grade level centered between the floor flange bolts nearest the Taxiway or Runway side of the sign. The sign as viewed will have the circuit card box to the right on the “A” side of the sign, which is closest to the Taxiway or Runway side of the sign. If the location requires an additional housing to accommodate multiple messages, then the separation distance between these signs housings can be 3 inches minimum to 12 inches maximum (FAA AC 150-5345-44J 3.2.5.2 a.). This first sign body housing (farthest from the adjacent Taxiway) will have the circuit card box to the left on the “A” side of the sign. The sign side identification is important with regards to its sign panel legend. A grounding rod and clamp should be installed at the end opposite the circuit card box in order to ground the sign housing. This grounding rod must not be connected to the field counterpoise.

**DANGER*****DANGER:*****Lock out electrical power to the series loop that will power the sign at its source before attempting any electrical connections/splices.**

- g. Make electrical connections to the series loop power using L-823 Primary Connector Kits. Attach the primary connectors to the appropriate size L-830 Series Isolation Transformer (See Tables 3-8). These primary connections (single pin plug or receptacle) should have Heat Shrink Kits applied over their connections to prevent disconnection and water from entering the cables. If two Series Isolation Transformers are required to be attached in series to obtain the correct wattage required for the sign, all primary lead connections should have Heat Shrink Kits applied. Two Series Isolation Transformers connected in series together will require a Consolidating Harness (Crouse-Hinds Part Number 26811-27) at the transformer secondary connectors (two pin receptacle) to series them together. Use electrical tape around the connections to prevent accidental disconnection. The Series

Instruction Manual
AGS-LED
858 LED Series
Sizes 1, 2, 3, 4 and 5

Isolation Transformer should be placed on a brick in order to isolate the transformer from direct contact with metal. The Series Isolation Transformer secondary cable should then be inserted from inside the housing up the conduit elbow. Using the two 40762 retainers supplied with the sign (looks like a cupped washer with a slot), placing one below the secondary cable receptacle (L-823 Style 8, looks like a ball), and one above. The bottom cupped washer sits on the conduit elbow top inside the threaded conduit coupling and prevents the secondary cable from dropping back down the conduit. The top cupped washer prevents the secondary cable from being pulled out of the ground allowing the sign power cord to disconnect if the sign is impacted and shears off at its frangible couplings. If a consolidating harness is used or a secondary cable extension (use electrical tape around connection) is required, use the 25003 (split clamp with screws and hex nuts) retainer supplied with the sign. Secure this retainer, flat side down away from sign, around the secondary end (L-823 Style 7, looks like a straight tube) that will exit the conduit elbow. The top of the secondary receptacle should be at least ¼ inch below the conduit elbow threaded coupling top surface.

**IMPORTANT****WARNING:**

Check the sign for shipping damage upon arrival and in all cases, check for damage prior to installation.

- h. Lower the sign with the legs and flanges into place. Plug the sign power cable plug into the secondary receptacle inside the conduit elbow while lowering. **Check the sign itself with a long carpenter's level to be sure it is level.** As an alternate, remove the floor flanges and frangible couplings from the sign, unscrewing the frangible couplings from the floor flanges. Install the floor flanges onto the sign anchor bolts. Level the floor flanges for ease of installation of the sign. A long carpenter's level can be placed across the top of the floor flanges to be sure they are all in line and level. Do not tighten the anchor nuts tight (only finger-tight) until the frangible couplings are installed back into to floor flanges. **Note:** Some vertical adjustments can be obtained by rotating the floor flanges a turn or two on the frangible coupling.
- i. Make sure all flanges are in **full** contact and sit flush on the pad before tightening the anchor bolts. Shim and grout as required. Once the sign has been leveled, attach the sign tether to the closest anchor bolt and tighten all the anchor nuts securely. (**Note:** Anchor hardware is not supplied with the sign.) Anchor hardware should be corrosion resistant. The sign body must not be bent or distorted due to an uneven installation procedure. Install a bare #14 AWG minimum copper ground wire to the sign ground stud (stud located on sign bottom extrusion exterior and accepts #4 through #14 AWG) and the other end to the grounding rod clamp.
- j. The sign is shipped set for a Ferro-resonant Type L-828 Regulator as illustrated in Table 1. For other Regulator types, set sign power supply circuit card jumper according to Table 2.
- k. Return power to series circuit and verify sign illuminates through all Regulator brightness steps.

10 Maintenance and Troubleshooting



WARNING

WARNING:

Remove Power Before Attempting Any Servicing.

10.1 General

Work on electrical circuits should be done only by a qualified electrician with a working knowledge of airfield lighting circuits. Trouble-shooting is accomplished by means of process of elimination. It should be checked that the **POWER** is **OFF** and secured, and once one solution is tried, **POWER** is reapplied. Then **POWER** turned **OFF** and secured and another solution tried, etc. Repeat this until the problem is solved.

It is also assumed that the circuit is in proper working order from the isolation transformer secondary connector (L-823 style 7 or 8 receptacle) all the way to and including the power source. Use of a calibrated true RMS-reading multi-meter with a current sensing clamp-on attachment will aid in the trouble shooting of electrical circuits. Warning: Only use OEM replacement sign legend panels



NOTICE

WARNING:

Only use OEM replacement sign legend panels. The entire message element must be replaced per FAA AC 150-5345-44J 3.2.5.10.2. Our proprietary process replacement panels meet the photometric and wind loading requirements of the sign as certified to FAA AC 150-5345-44J.



CAUTION

CAUTION:

Do not over tighten hex nut on stud retaining bridge rectifier. 8in-lbs max. (See Figure 18) Also, remover carriers from thermal pad adhesive surfaces before installing.



IMPORTANT

WARNING:

When tightening cover screws, do not use power drivers as you may exceed the maximum torque of 75 in-lbs on the cover screws.



DANGER

DANGER:

When replacing parts inside the circuit box or sign housing, lock out series circuit power at its source.

10.2 Problem Solving Guide

PROBLEM	POSSIBLE CAUSE	CORRECTIVE ACTION
(P.1) Sign will not light	No input current. (LEDs on Power Supply board not lit)	Measure input current according to Sections 10.3 and 10.4. If the measured input current is not within spec (see Tables 9-11), check CCR, isolation transformer, and primary power connections.

Instruction Manual
AGS-LED
858 LED Series
Sizes 1, 2, 3, 4 and 5

PROBLEM	POSSIBLE CAUSE	CORRECTIVE ACTION
(P.2) Sign will not light	Input current is below or exceeds specification. (Input current is specified between 2.8 and 6.6 amps using a true RMS Ammeter. L858 Power Supply indicator RED LEDs D4 is ON, and D7 is OFF; Table 12)	Adjust CCR current (See Tables 9-11 and/or replace isolation transformer with appropriate wattage for sign (see Tables 3-8).
(P.3) Sign will not light	Optional ON/OFF switch in OFF position	Turn switch to ON position.
(P.4) Sign will not light	Power Supply Circuit Card +15V supply failed (See Table 12)	Verify Green LED D29 is lit. Replace Power Supply Board if D29 is not lit.(Section 10.12)
(P.5) Sign will not light	Power Supply Circuit Card +3.3V supply failed (See Table 12)	Verify Green LED D11 is lit. Replace Power Supply Board if D11 is not lit (section 10.12).
(P.6) Sign will not light	Loose/broken wire(s)/missing connections	Verify Power Supply connections match Power Supply Wiring Diagram (Figures 18 & 21).
(P.7) Sign will not light	Output Electrical Open Circuit (See Table 12)	Verify LED cable connectors are properly seated in their respective receptacles; reseat if necessary (See Sections 10.5 & 10.6)
(P.8) Sign will not light	LED MODULE(s) mounted/wired incorrectly	Verify that LED MODULES are mounted and wired according to LED Array Wiring Diagram. (See Figures 7-11 and Sections 10.7-10.9)
(P.9) Sign will not light	LED MODULE(s) open circuit failure (Assumes P.7 Action taken)	Replace suspected open circuit LED MODULE with spare known good LED

Instruction Manual
AGS-LED
858 LED Series
Sizes 1, 2, 3, 4 and 5

PROBLEM	POSSIBLE CAUSE	CORRECTIVE ACTION
		MODULE(s) (See Sec 10.10)
(P.10) Upon applying power, sign momentarily lights and then turns off.	Incorrect LED Power Supply Circuit Board Switch Configuration	Verify/Set Power Supply Board Switches and jumpers are set according to Table 1 (Ferro CCR) or Table 2 (Series CCR)
(P.11) Upon applying power, sign momentarily lights and then turns off.	LED MODULE Voltage has dropped 25% below the calibrated output voltage (See Table 12).	Replace any LED MODULE(s) with non-lit LEDs and re-calibrate the LED Power Supply. (See Sections 10.10 & 10.11)
(P.12) Upon applying power, sign momentarily lights and then turns off.	LED MODULE Voltage is greater than 125% of the expected calibrated output voltage (See Table 12).	Verify/Set Power Supply Board Switches and jumpers are set according to Table 1 (Ferro CCR) or Table 2 (Series CCR)
(P.13) Sign flickering	Incorrect LED Power Supply Circuit Board Jumper Setting.	Verify/Set Jumpers JP1 and JP2 according to the Table 1 (FERRO CCR) or Table 2 (Series CCR)
(P.14) Sign flickering	Incorrect Isolation Transformer	Replace with Isolation transformer that matches sign type, size, #modules. (See Tables 3-8)

10.3 Measuring Input Current (Signs Without Optional Power Switch)

**WARNING*****WARNING:***

Failure to turn off power to the sign and wait five minutes could result in severe injury or death.

Turn off power to the sign by turning off the corresponding Constant Current Regulator (CCR) power. (**WARNING: Wait five minutes after sign power is turned off to service the sign. This will allow any residual high voltage stored in Power Supply PCB components to bleed off.**) With your multimeter set to DC Volts, verify that the Power Supply Output Voltage is less than 30-VDC at TP6 (Positive lead) and TP3 (Negative Lead) as indicated in Figure 22. If the Power Supply Output Voltage is greater than 30-VDC, then you must wait until the Power Supply Output Voltage drops below 30-VDC before you proceed with the next step.

Open Power Supply cover (See Figure 18). Disconnect female crimp receptacle at CN17 from Power Supply Board. (Note: When removing female crimp receptacle, grasp by the terminal, not the wire.) Disconnect female crimp receptacle from CN18 and connect to CN17. Place current clamp around primary power wire and connect to a true rms current meter. Turn on power to the CCR. Current should measure between 2.7-ARMS and 6.7-ARMS depending on the CCR current level or current step.

Upon completing the measurement of the input current, turn off power to the CCR. Remove the current clamp. Disconnect the female crimp receptacle at CN17 and reconnect to CN18. Reconnect the female crimp receptacle attached to wire BRPH to CN18. Close the Power Supply Box cover.

10.4 Measuring Input Current (Signs With Optional Power Switch)

**WARNING*****WARNING:***

Failure to turn off power to the sign and wait five minutes could result in severe injury or death.

Turn off power to sign by toggling sign power switch to the off position (See Figure 6). Turn off power to the sign. (**WARNING: Wait five minutes after sign power is turned off to service the sign. This will allow any residual high voltage stored in Power Supply PCB components to bleed off.**) With your multimeter set to DC Volts, verify that the Power Supply Output Voltage is less than 30-VDC at TP6 (Positive lead) and TP3 (Negative Lead) as indicated in Figure 22. If the Power Supply Output

Instruction Manual
AGS-LED
858 LED Series
Sizes 1, 2, 3, 4 and 5

Voltage is greater than 30-VDC, then you must wait until the Power Supply Output Voltage drops below 30-VDC before you proceed with the next step.

Open the Power Supply Box cover. Place current clamp around one of the wires connected to the switch labeled with switch marker PWR. Connect the current clamp to the true RMS current meter. Measure the input current. Current should measure between 2.7-ARMS and 6.7-ARMS depending on the CCR current level or current step.

Upon completing the measurement of the input current, remove current clamp and close Power Supply Box cover.

10.5 Checking Power Supply LED Cable



WARNING

WARNING:

Failure to turn off power to the sign and wait five minutes could result in severe injury or death.

Turn off power to the sign. (**WARNING: Wait five minutes after sign power is turned off to service the sign. This will allow any residual high voltage stored in Power Supply PCB components to bleed off.**) With your multimeter set to DC Volts, verify that the Power Supply Output Voltage is less than 30-VDC at TP6 (Positive lead) and TP3 (Negative Lead) as indicated in Figure 21. If the Power Supply Output Voltage is greater than 30-VDC, then you must wait until the Power Supply Output Voltage drops below 30-VDC before you proceed with the next step.

Remove the sign top cover bolts and then lift the top cover from the sign. Remove the front face from the sign. Check the Power Supply LED Cable for visible damage. Make sure the Power Supply LED cable connector is properly seated in CN9 at the Power Supply Board (see Figure 18). Verify that the Power Supply LED cable connector connects to the input connector of the first LED MODULE and is properly seated in the input connector housing. The LED MODULE input connector and the output connector are clearly marked with inward pointing and outward pointing black arrows, respectively, on the LED MODULE PCB (see Figure 7).

10.6 Checking LED MODULE Cable Connections



WARNING

WARNING:

Failure to turn off power to the sign and wait five minutes could result in severe injury or death.

Turn off power to the sign by turning off the corresponding Constant Current Regulator (CCR) power. (**WARNING: Wait five minutes after sign power is turned off to service the sign. This will allow any residual high voltage stored in Power Supply PCB components to bleed off.**) With your multimeter set to DC Volts, verify that the Power Supply Output Voltage is less than 30-VDC at TP6 (Positive lead) and TP3 (Negative Lead) as indicated in Figure 22. If the Power Supply Output Voltage is greater than 30-VDC, then you must wait until the Power Supply Output Voltage drops below 30-VDC before you proceed with the next step.

The LED MODULES are electrically wired in series. This means that if **any** of the cable connectors are improperly seated in their respective LED MODULE housing, then no current can flow through any of the LED MODULES and subsequently the sign will not light. Therefore, verify that all cable connectors are properly seated in their housing and that the output of one LED MODULE (indicated by the outward pointing arrow at the LED MODULE connector Figure 7) is connected to the input of the next LED MODULE (indicated by the inward pointing arrow at the LED MODULE connector- Figure 7).

The Last LED MODULE in the series string is terminated with a black return connector & cable assembly (See Figure 7-11). Verify that the black terminator cable connector is properly inserted into the connector housing at the Last LED MODULE output connector (indicated by the inward pointing arrow).

10.7 Checking the First LED MODULE



WARNING

WARNING:

Failure to turn off power to the sign and wait five minutes could result in severe injury or death.

Instruction Manual
AGS-LED
858 LED Series
Sizes 1, 2, 3, 4 and 5

Turn off power to the sign by turning off the corresponding Constant Current Regulator (CCR) power. **(WARNING: Wait five minutes after sign power is turned off to service the sign. This will allow any residual high voltage stored in Power Supply PCB components to bleed off.)** With your multimeter set to DC Volts, verify that the Power Supply Output Voltage is less than 30-VDC at TP6 (Positive lead) and TP3 (Negative Lead) as indicated in Figure 22. If the Power Supply Output Voltage is greater than 30-VDC, then you must wait until the Power Supply Output Voltage drops below 30-VDC before you proceed with the next step.

Remove the black return cable connector from the last LED MODULE output cable connector (see Figures 7-11 & 20). Replace the output cable connector in the first LED MODULE with the black return cable connector. Turn on main power. If the first LED MODULE momentarily lights and then turns off, then the first LED MODULE and the Power Supply LED cable and Power Supply board are operating normally.

Turn off main power to the sign. Wait five minutes for the power supply voltages to dissipate. Verify that the output voltage is less than 30-VDC with a multimeter as described in the opening paragraph of this section. Replace the black return cable connector with the first LED MODULE output cable connector. If the sign does not light at all, then replace the LED MODULE #1 and/or the cable connecting from the output of the Power Supply to the input of LED MODULE #1 (see Section 10.10). Then repeat the test described above in this section.

10.8 Checking the Second LED MODULE



WARNING

WARNING:

Failure to turn off power to the sign and wait five minutes could result in severe injury or death.

Turn off power to the sign by turning off the corresponding Constant Current Regulator (CCR) power. **(WARNING: Wait five minutes after sign power is turned off to service the sign. This will allow any residual high voltage stored in Power Supply PCB components to bleed off.)** With your multimeter set to DC Volts, verify that the Power Supply Output Voltage is less than 30-VDC at TP6 (Positive lead) and TP3 (Negative Lead) as indicated in Figure 22. If the Power Supply Output Voltage is greater than 30-VDC, then you must wait until the Power Supply Output Voltage drops below 30-VDC before you proceed with the next step.

Remove the black return cable connector from the last LED MODULE output cable connector (see Figure 20). Replace the output cable connector in the second LED MODULE with the black return cable connector. Turn on main power to the sign. If both LED MODULES momentarily light and then turn off

Instruction Manual
AGS-LED
858 LED Series
Sizes 1, 2, 3, 4 and 5

or stays lit, then the second LED MODULE and the cable from the first LED MODULE to the second LED MODULE are operating normally.

Turn off main power to the sign. Wait five minutes for the high voltage to dissipate. Verify that the output voltage is less than 30-VDC with a multimeter as described in the opening paragraph of this section. Replace the black return cable connector with the first LED MODULE output cable connector. Replace the black return cable connector in the output connector housing of the last LED MODULE.

If the sign does not light at all, then replace the second LED MODULE and/or the cable connecting from the output connector of LED MODULE #1 to the input of LED MODULE #2 (see Section 10.10). Then repeat the test outlined above in this section.

10.9 Continue Checking the Rest of the LED MODULES

It is assumed that the first two LED MODULES have been checked successfully as described in previous two sections. For signs with more than two LED MODULES, continue checking the remaining LED MODULES one at a time and in numerical sequence (e.g. LED MODULE #3, LED MODULE #4....LED MODULE #Last). Use the same method as we have outlined in previous section.

For example, suppose we have a sign with 6 LED MODULES (See Size 2, 2-Modules, Figure 9) and we have checked all the LED MODULES in sequence from 1 to from 4 and found that the sign momentarily lit. Then we would use the following procedure to test the 5th LED MODULE.



WARNING

WARNING:

Failure to turn off power to the sign and wait five minutes could result in severe injury or death.

Turn off power to the sign by turning off the corresponding Constant Current Regulator (CCR) power. (**WARNING: Wait five minutes after sign power is turned off to service the sign. This will allow any residual high voltage stored in Power Supply PCB components to bleed off.**) With your multimeter set to DC Volts, verify that the Power Supply Output Voltage is less than 30-VDC at TP6 (Positive lead) and TP3 (Negative Lead) as indicated in Figure 22. If the Power Supply Output Voltage is greater than 30-VDC, then you must wait until the Power Supply Output Voltage drops below 30-VDC before you proceed with the next step.

Remove the black return cable connector from the 6th LED MODULE output cable connector (see Figure 20). Replace the output cable connector in the LED MODULE #5 with the black return cable connector.

Instruction Manual
AGS-LED
858 LED Series
Sizes 1, 2, 3, 4 and 5

Turn on main power to the sign. If LED MODULES #1 to #5 momentarily light and then turn off, then the LED MODULE #5 and the cable from the LED MODULE #4 to the LED MODULE #5 are operating normally.

**WARNING****WARNING:**

Failure to turn off power to the sign and wait five minutes could result in severe injury or death.

Turn off main power to the sign. Wait five minutes for the high voltage to dissipate. Verify that Power Supply Output Voltage measures less than 30-VDC, as described above. Replace the black return cable connector with the LED MODULE #5 output cable connector. Replace the black return cable connector into the output connector housing of the 6th LED MODULE.

If the sign does not light at all, then replace the LED MODULE #5 and/or the cable connecting from the output connector of LED MODULE #4 to the input of LED MODULE #5 (see Section 10.10). Then repeat the test as described in this section.

10.10 Replacing an LED MODULE

In the case where an LED MODULE has failed and needs to be replaced use the following instructions:

INSTRUCTIONS FOR REPLACING AN LED MODULE

The following instructions assume that the sign front face is removed and that the failed LED MODULE has been previously identified.

**WARNING****WARNING:**

Failure to turn off power to the sign and wait five minutes could result in severe injury or death.

1. Turn off power to the sign by turning off the corresponding Constant Current Regulator (CCR) power. **(WARNING: Wait five minutes after sign power is turned off to service the sign. This will allow any residual high voltage stored in Power Supply PCB components to bleed off.)**

Instruction Manual
AGS-LED
858 LED Series
Sizes 1, 2, 3, 4 and 5

2. With your multimeter set to DC Volts, verify that the Power Supply Output Voltage is less than 30-VDC at TP6 (Positive lead) and TP3 (Negative Lead) as indicated in Figure 22. If the Power Supply Output Voltage is greater than 30-VDC, then you must wait until the Power Supply Output Voltage drops below 30-VDC before you proceed with the next step.
3. Carefully remove the input and output cables from the failed LED MODULE. (Mark the cable connected to the LED MODULE input connector. **Note: The input connector on the LED MODULE is denoted by a black arrow pointing toward the input connector (see Figure 7).**)
4. Loosen and remove the nuts on the LED MODULE mounting bracket bolts. Remove the LED MODULE bracket bolts with one hand while support the LED MODULE with your other hand.
5. Carefully remove the failed LED MODULE from the LED MODULE mounting bracket.
6. Mount the replacement LED MODULE into the mounting bracket such that the holes in the LED MODULE heat sink are aligned with the mounting bracket holes. (Note: The replacement LED MODULE input connector should be closest to the marked input cable connector.)
7. Push the mounting bracket bolts through the mounting bracket and the LED MODULE heat sink holes.
8. Attach nuts to the mounting bracket bolts and tighten.
9. Gently slide the input cable connector into the replacement LED MODULE connector input housing.
10. Likewise, slide the output cable connector into the replacement LED MODULE output connector housing.
11. The LED MODULE replacement is complete.
12. Power Supply Board must be re-calibrated after replacing an LED MODULE (see Section 10.11).



IMPORTANT

WARNING:

Power Supply Board must be re-calibrated after replacing an LED MODULE (see Section 10.11).

10.11 Sign PC Board P/N 62277 Calibration

The 62277 PC Board doesn't normally need to be calibrated in the field unless an LED MODULE is replaced.



IMPORTANT

WARNING:

In this section, it is assumed that the Sign PC Board P/N 62277 is correctly configured for this particular sign (see Table 1 or 2) and that the sign lights continuously when main power is applied in the normal mode of operation (SW3-1 = OFF).

INSTRUCTIONS FOR CALIBRATION OF 62277 PC BOARD:

1. Turn off main power to the sign.
2. Open the Power Supply Cover and locate SW3-1 on the Power Supply Board (See Figure 18)
3. On the Power Supply Board, set switch SW3-1 to the ON position.
4. Apply main power to the sign. Green LED D3 will flash ON/OFF slowly for approximately three seconds to indicate the beginning of the calibration process. During calibration, D3, will remain OFF. At the conclusion of the calibration process, D3 remain constant ON (see Figure 18).
5. If D3 does not light and remain constant, then calibration has failed. Based on the assumption listed under WARNING above, replace the power supply board (See section 10.12)
5. Turn off the main power to the sign.
6. Set SW3-1 to the OFF position.
7. Close the Power Supply cover.
8. The Power Supply Board is now calibrated to the sign.

10.12 Replacing Sign Power Supply Board & Heat Sink P/N 62277

In this section, it is assumed that the sign has failed and the trouble shooting guide recommends replacement of the Power Supply Board.

INSTRUCTIONS FOR REPLACING 62277 PC BOARD & HEAT SINK:

Instruction Manual
AGS-LED
858 LED Series
Sizes 1, 2, 3, 4 and 5



IMPORTANT

WARNING:

**Power Supply Board must be re-calibrated after replacement.
(see Section 10.11).**

1. Turn off power to the sign by turning off the corresponding Constant Current Regulator (CCR) power. **(WARNING: Wait five minutes after sign power is turned off to service the sign. This will allow any residual high voltage stored in Power Supply PCB components to bleed off.)**



WARNING

WARNING:

Failure to turn off power to the sign and wait five minutes could result in severe injury or death.

2. With your multimeter set to DC Volts, verify that the Power Supply Output Voltage is less than 30-VDC at TP6 (Positive lead) and TP3 (Negative Lead) as indicated in Figure 22. If the Power Supply Output Voltage is greater than 30-VDC, then you must wait until the Power Supply Output Voltage drops below 30-VDC before you proceed with the next step.
3. Remove input power cabling at CN1, CN2, CN3, CN11, CN17, & CN18 (See Figure 15).
4. Remove LED Power Supply Cable at CN9 (See Figure 15).
5. Remove the three nuts that secure the main heat sink to the Power Supply Box.
6. Remove the six screws that fasten the Power Supply Board onto the Power Supply Box.
7. Remove the Power Supply Board Assembly by sliding the attached main heat sink off the mounting studs extending from the side of the Power Supply Box.
8. Slide the new Power Supply Board onto the mounting studs extending from the side of the Power Supply Box.
9. Fasten board to the Power Supply Box with six mounting screws.
10. Attach the three nuts that secure the heat sink to the studs extending from the side of the Power Supply Box.
11. Connect the LED Power Supply cable at CN9.
12. Connect the input power cabling at CN1, CN2, CN3, CN11, CN17, & CN18.
13. Set the jumpers JP1 & JP2 for the sign style, size, and number of modules as shown in Table 1 or 2. (For location, see Figure 18)

Instruction Manual
AGS-LED
858 LED Series
Sizes 1, 2, 3, 4 and 5

14. Set DIP switches SW1, SW2, & SW3 for the sign style, size, and number of modules as shown in Table 1 or 2. (For locations Figure 18)
15. The Power Supply Board and Heat Sink replacement is complete

Instruction Manual
AGS-LED
858 LED Series
Sizes 1, 2, 3, 4 and 5

11 Figures and Tables

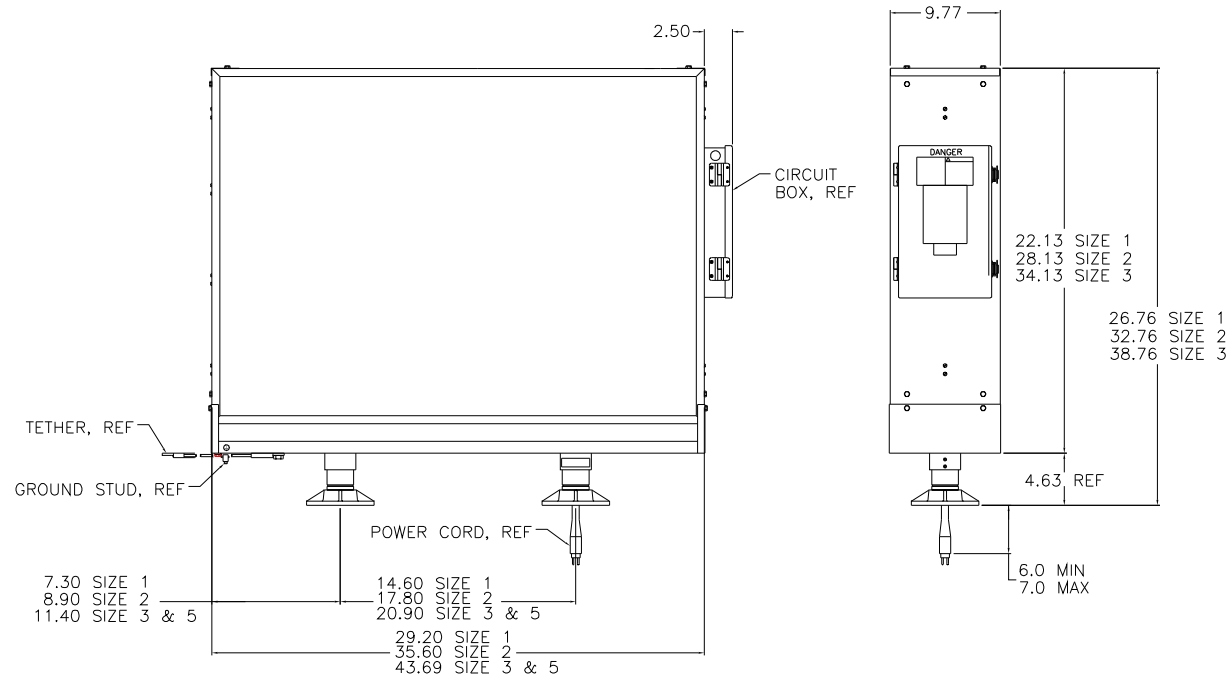

SIZE 3 ONE MODULE & SIZE 5 DISTANCE MARKER SIDE A SHOWN
 NORMAL SIDE A CIRCUIT BOX LOCATION IS ON RIGHT AS SHOWN
 SEE SIGN LEGEND LAYOUT FOR SIDE A POWER CORD LOCATION. CIRCUIT
 BOX IS ON THE SAME SIDE AS THE POWER CORD, BUT IS NOT ILLUSTRATED
 ON THE LEGEND LAYOUT.

Figure 1. Single module sign

Instruction Manual
AGS-LED
858 LED Series
Sizes 1, 2, 3, 4 and 5

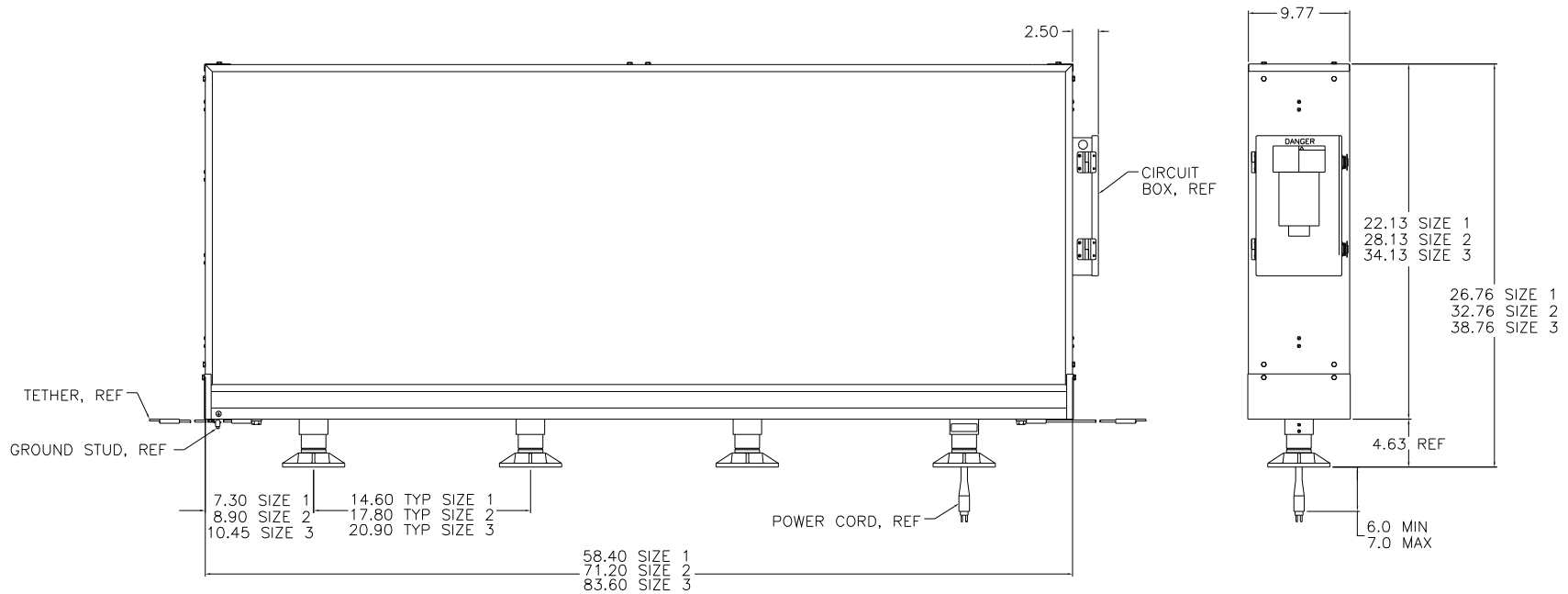

SIZE 3 TWO MODULE SIDE A SHOWN
 NORMAL SIDE A CIRCUIT BOX LOCATION IS ON RIGHT AS SHOWN
 SEE SIGN LEGEND LAYOUT FOR SIDE A POWER CORD LOCATION. CIRCUIT
 BOX IS ON THE SAME SIDE AS THE POWER CORD, BUT IS NOT ILLUSTRATED
 ON THE LEGEND LAYOUT.

Figure 2. Double module sign

Instruction Manual
AGS-LED
858 LED Series
Sizes 1, 2, 3, 4 and 5

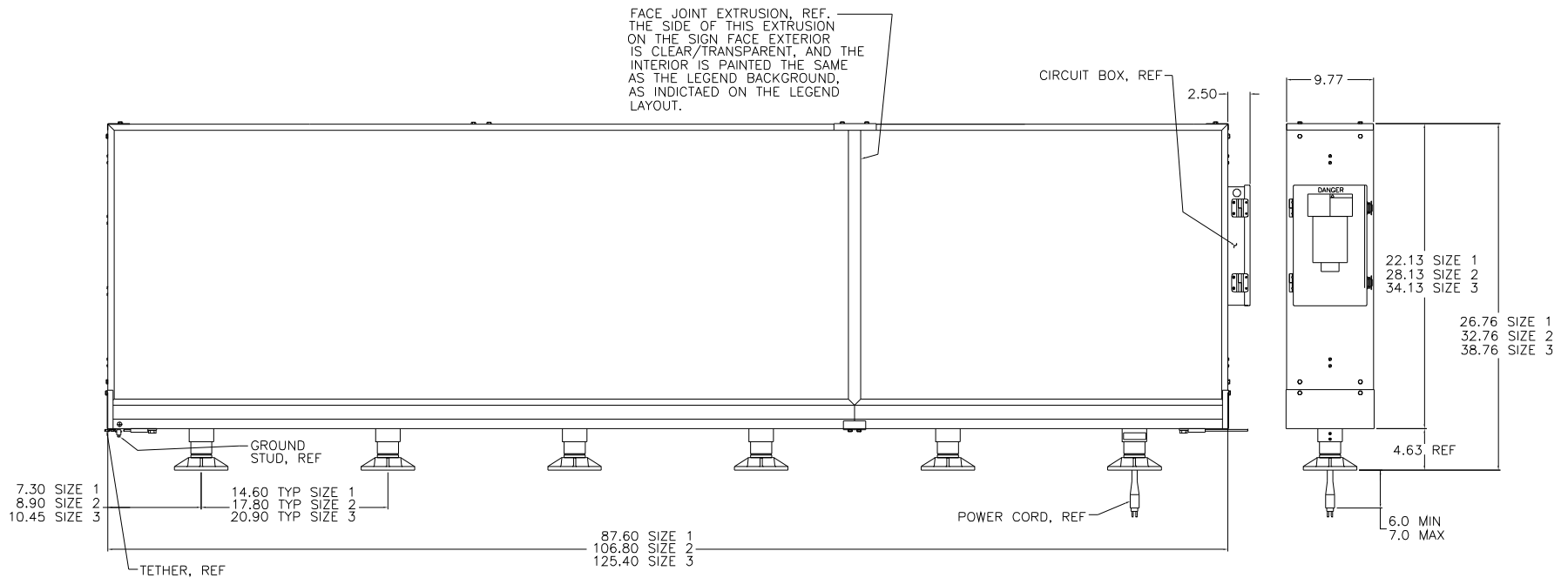

SIZE 3 THREE MODULE SIDE A DOUBLE-SINGLE (D-S) CONFIGURATION SHOWN
NORMAL SIDE A CIRCUIT BOX LOCATION IS ON RIGHT AS SHOWN

THIS SIGN CAN ALSO BE CONFIGURED AS A SINGLE-DOUBLE (S-D). SEE LEGEND LAYOUT.
SEE SIGN LEGEND LAYOUT FOR SIDE A POWER CORD LOCATION. CIRCUIT BOX IS ON THE SAME SIDE AS THE POWER CORD, BUT IS NOT ILLUSTRATED ON THE LEGEND LAYOUT.

Figure 3. Three module sign

Instruction Manual
AGS-LED
858 LED Series
Sizes 1, 2, 3, 4 and 5

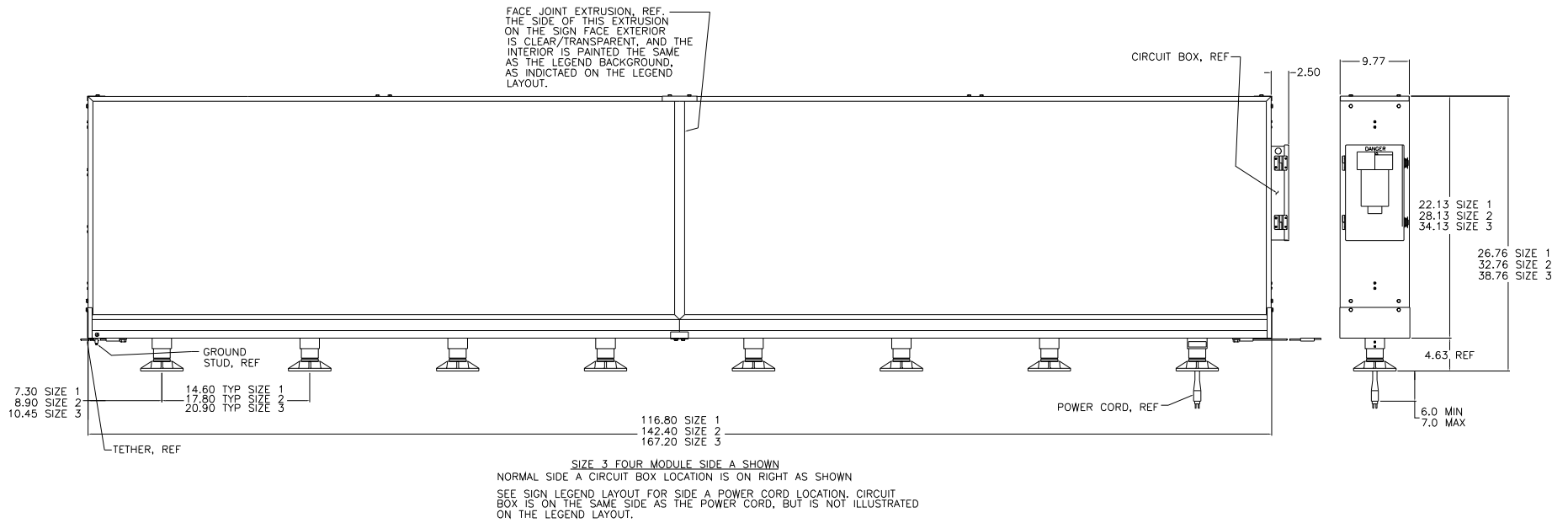
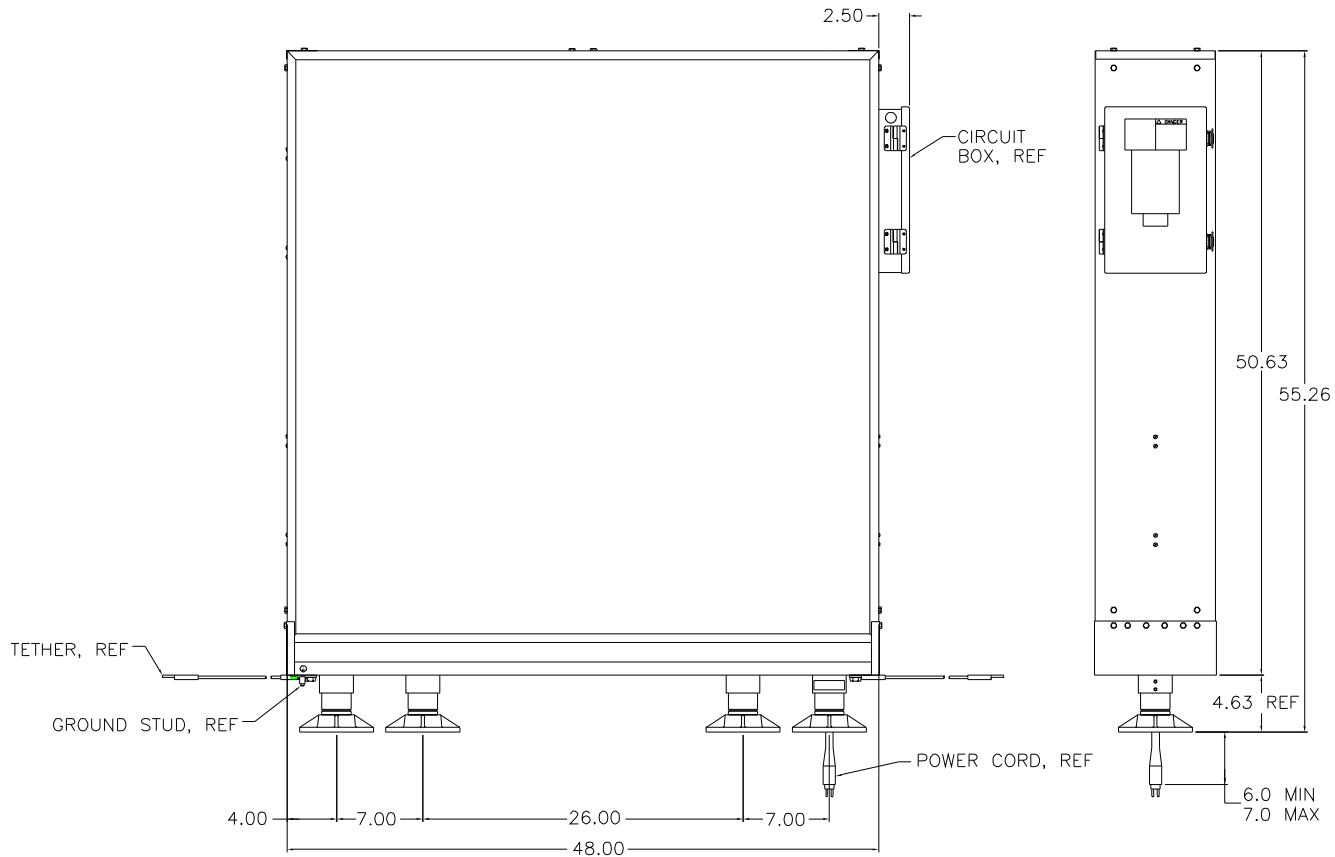

Figure 4. Four module sign

Instruction Manual
AGS-LED
858 LED Series
Sizes 1, 2, 3, 4 and 5



SIZE 4 DISTANCE MARKER SIDE A SHOWN
NORMAL SIDE A CIRCUIT BOX LOCATION IS ON RIGHT AS SHOWN
SEE SIGN LEGEND LAYOUT FOR SIDE A POWER CORD LOCATION. CIRCUIT
BOX IS ON THE SAME SIDE AS THE POWER CORD, BUT IS NOT ILLUSTRATED
ON THE LEGEND LAYOUT.

Figure 5. Distance Marker

Instruction Manual
AGS-LED
858 LED Series
Sizes 1, 2, 3, 4 and 5

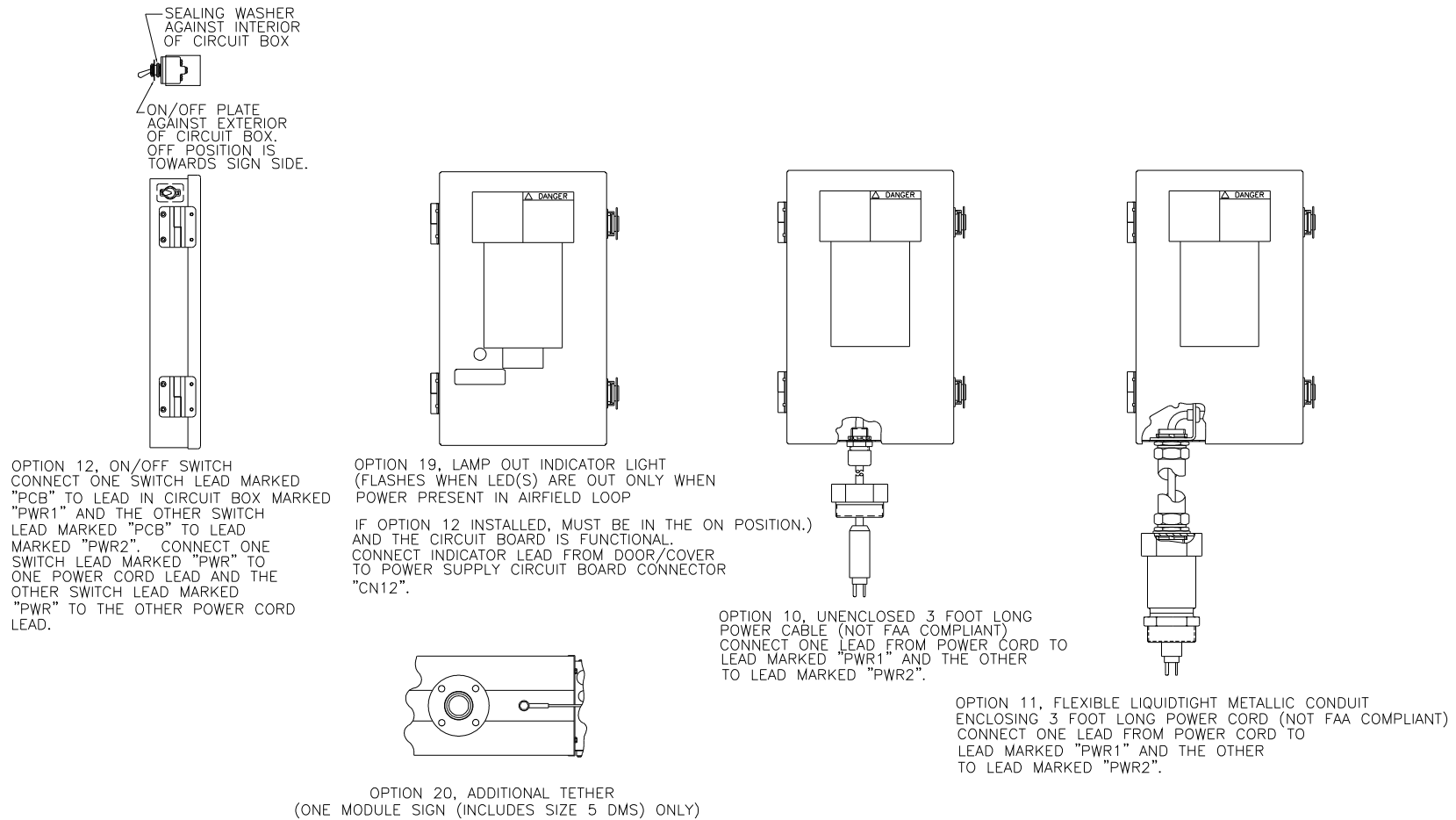

Figure 6. Sign Options

Instruction Manual
AGS-LED
858 LED Series
Sizes 1, 2, 3, 4 and 5

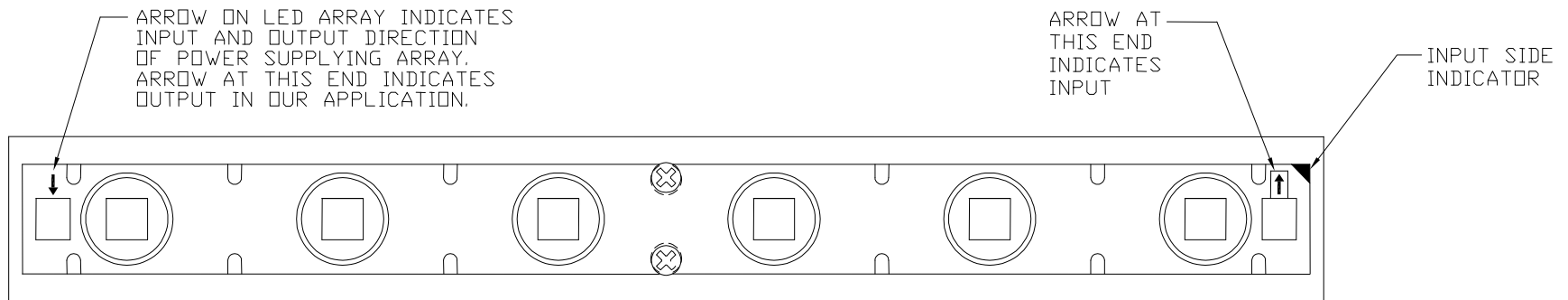
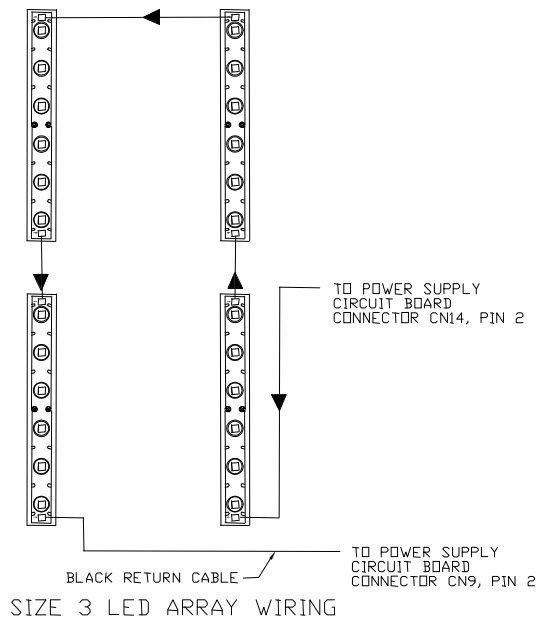
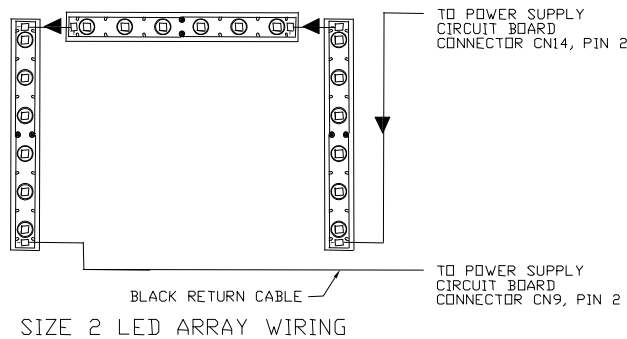
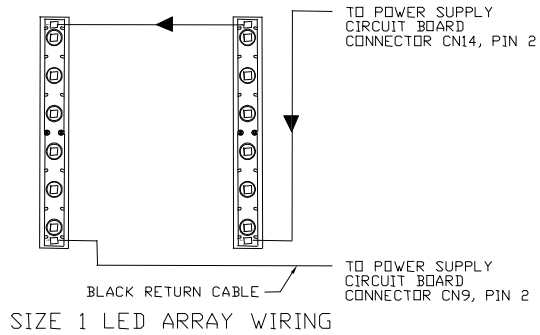

Figure 7. Heat Sink/LED Assembly showing wiring input and output connections

Instruction Manual
AGS-LED
858 LED Series
Sizes 1, 2, 3, 4 and 5



**Figure 8. LED Array Wiring, One Module Signs
(Reference Figure 7 for LED array orientations)**

Instruction Manual
AGS-LED
858 LED Series
Sizes 1, 2, 3, 4 and 5

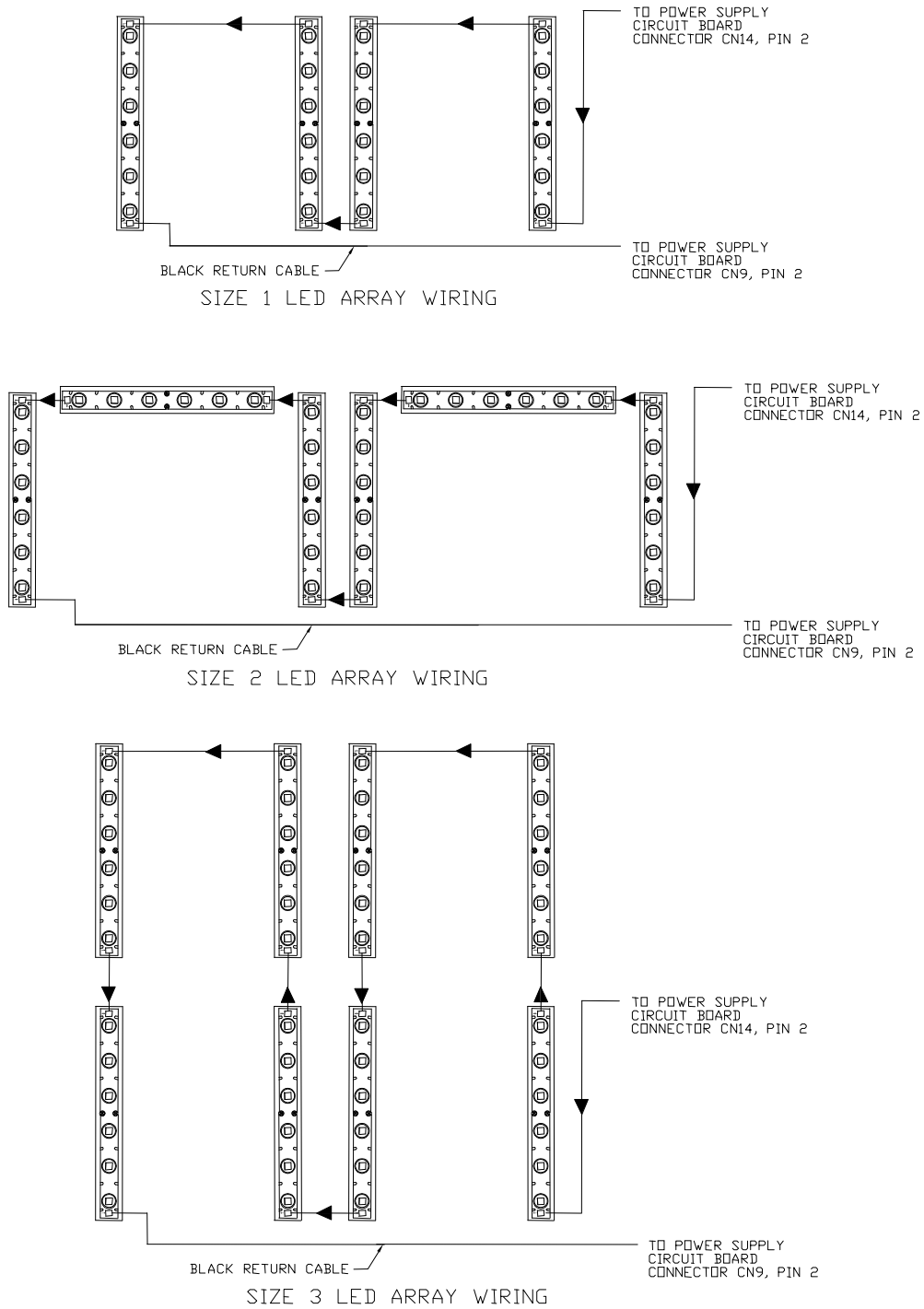

**Figure 9. LED Array Wiring, Two Module Signs
(Reference Figure 7 for LED array orientations)**

Instruction Manual
AGS-LED
858 LED Series
Sizes 1, 2, 3, 4 and 5

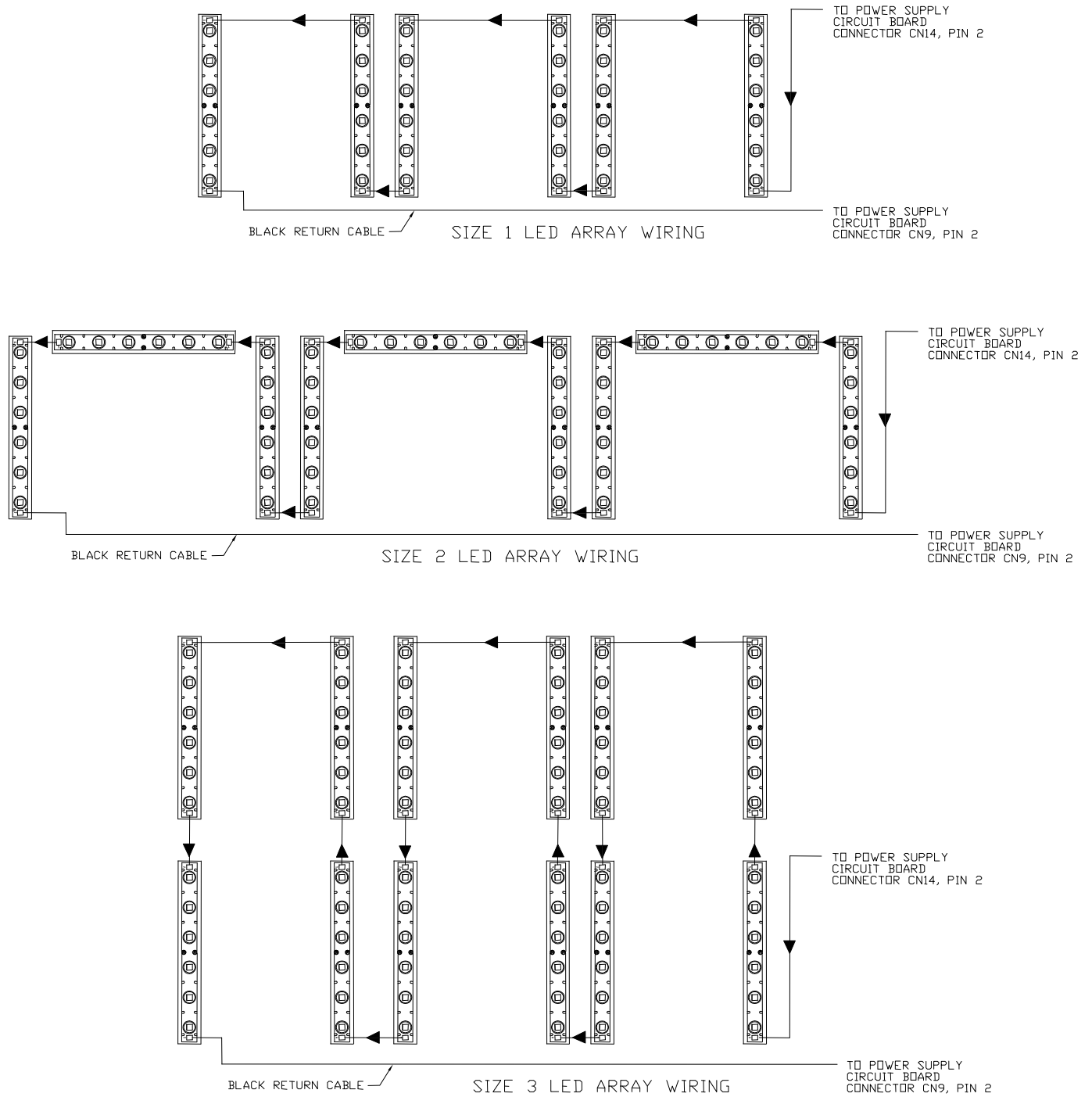
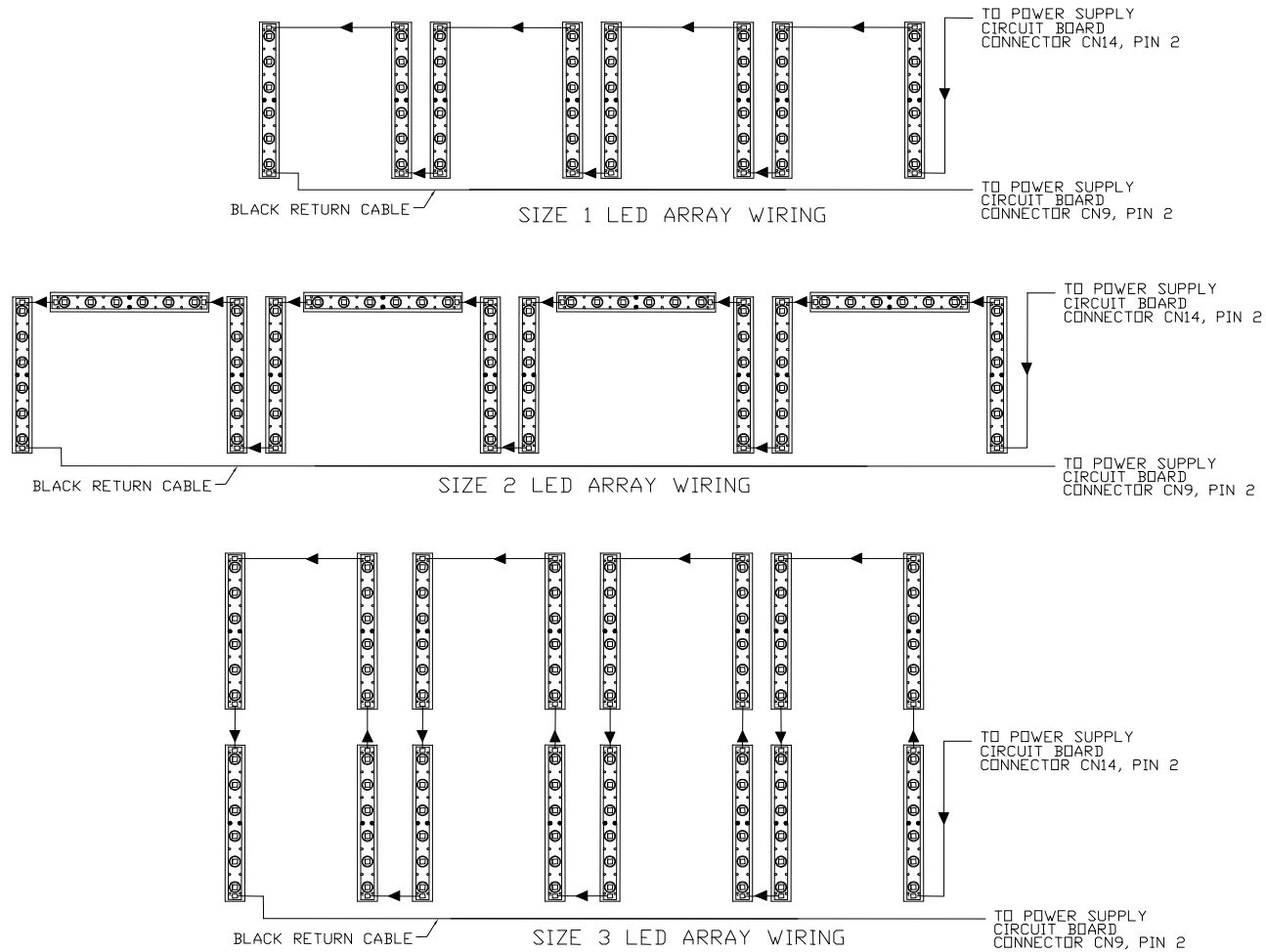

Figure 10. LED Array Wiring, Three Module Signs
(Reference Figure 7 for LED array orientations)

Instruction Manual
AGS-LED
858 LED Series
Sizes 1, 2, 3, 4 and 5



**Figure 10. LED Array Wiring, Four Module Signs
(Reference Figure 7 for LED array orientations)**

Instruction Manual
AGS-LED
858 LED Series
Sizes 1, 2, 3, 4 and 5

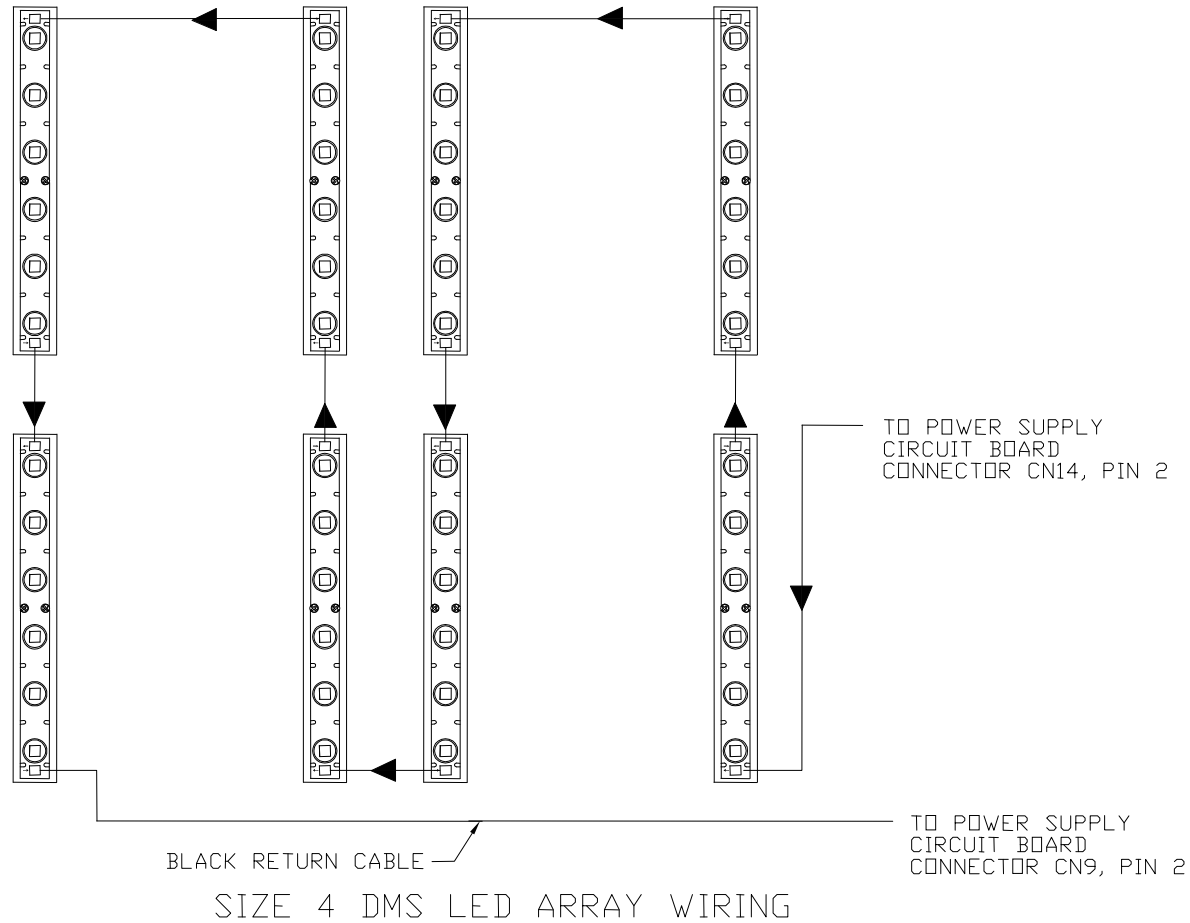

**Figure 11. LED Array Wiring, Distance Marker
(Reference Figure 7 for LED array orientations)**

Instruction Manual
AGS-LED
858 LED Series
Sizes 1, 2, 3, 4 and 5

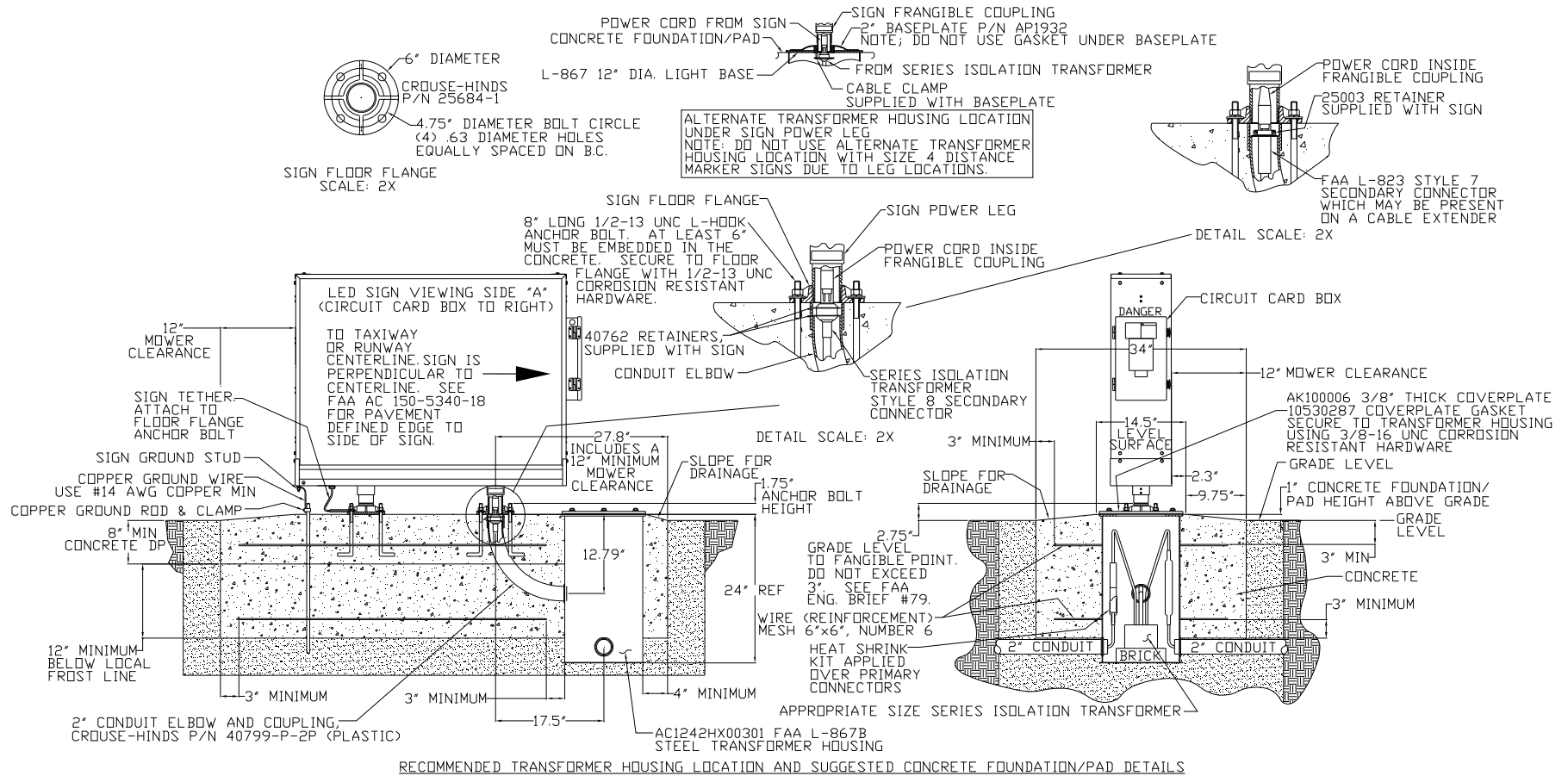

Figure 12. Recommended Transformer Housing Location & Concrete Foundation/Pad Details

Instruction Manual
AGS-LED
858 LED Series
Sizes 1, 2, 3, 4 and 5

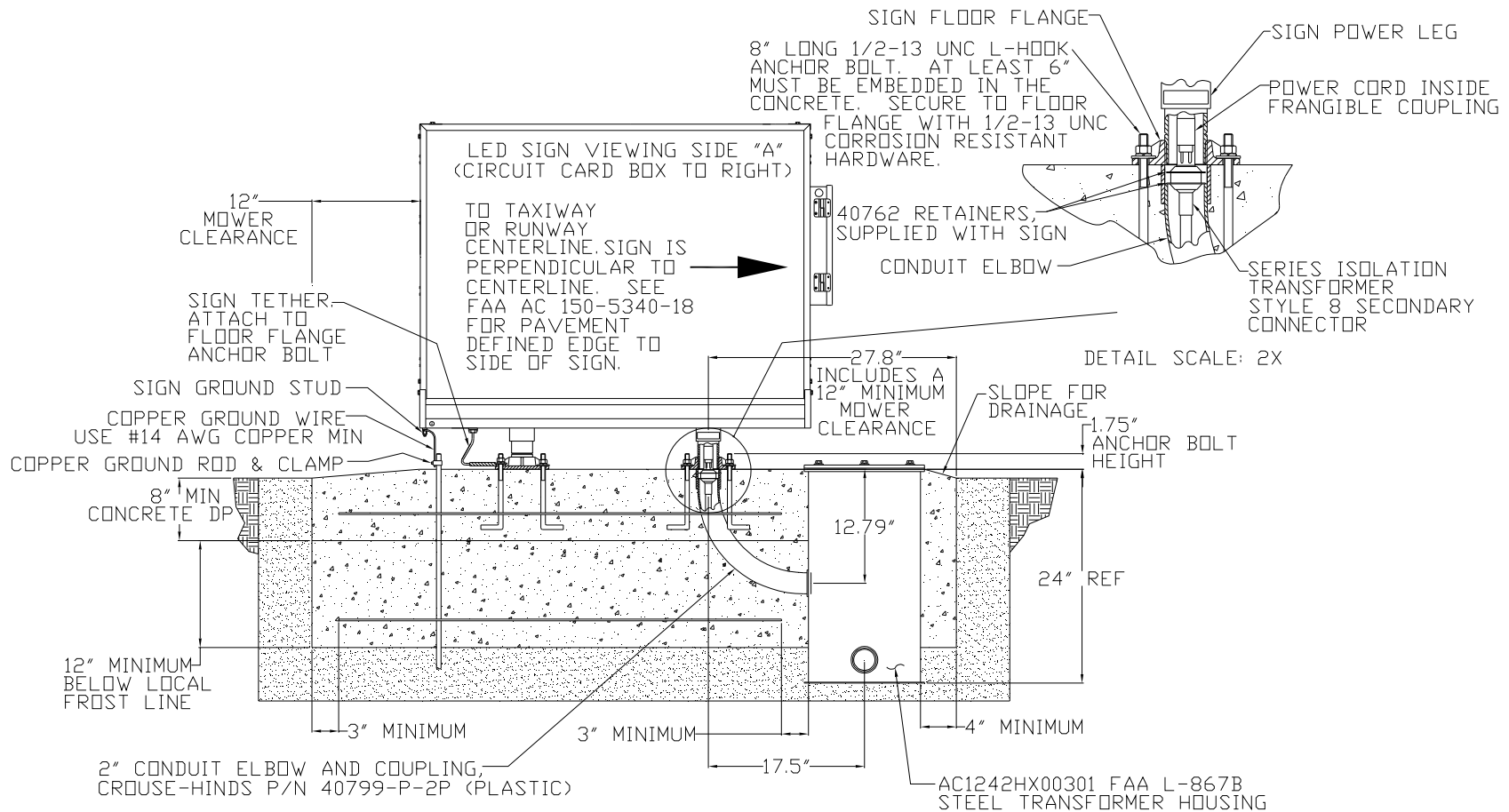

Figure 12a. Expanded left section of Figure 12

Instruction Manual
AGS-LED
858 LED Series
Sizes 1, 2, 3, 4 and 5

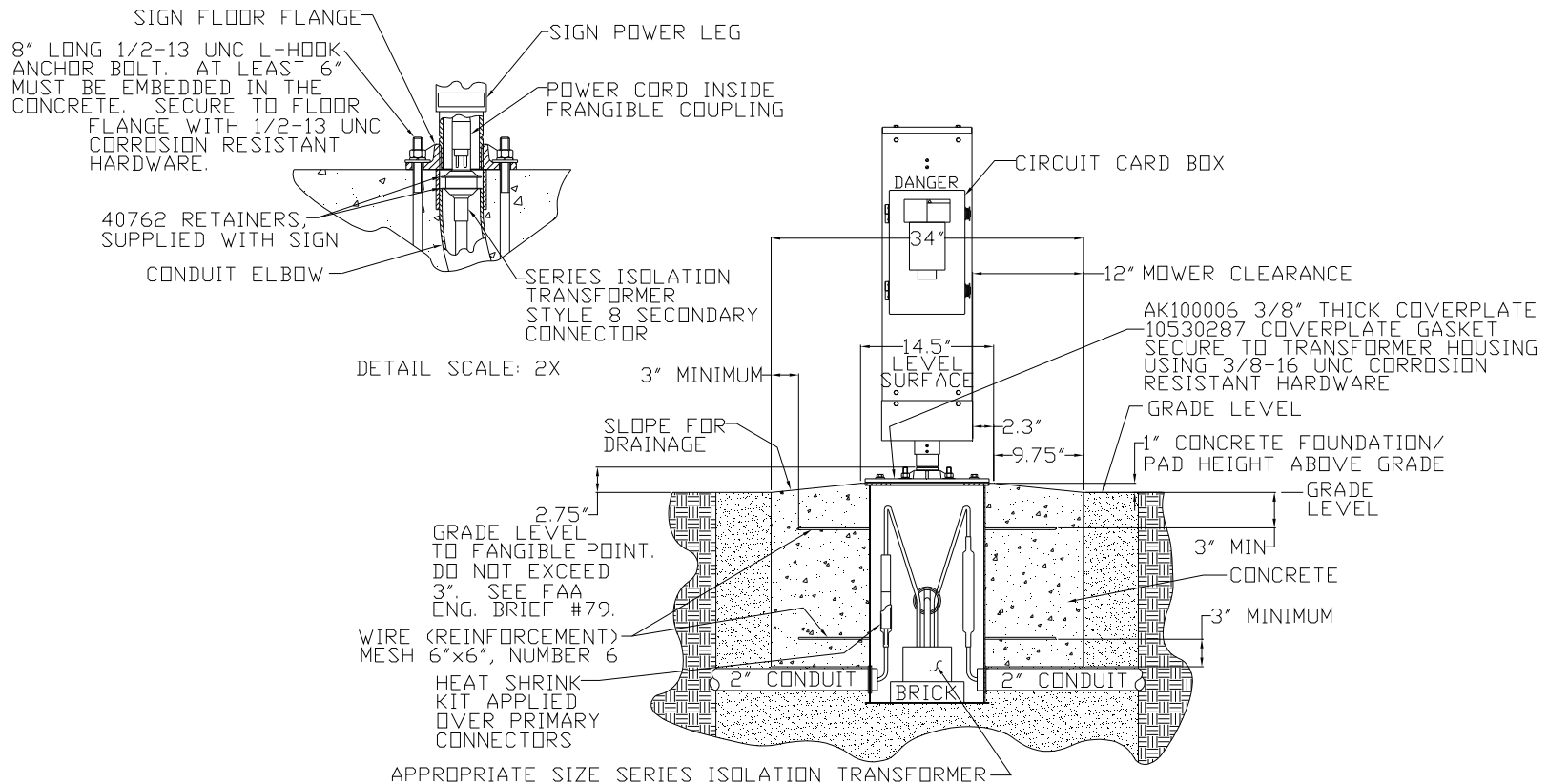

Figure 12b. Expanded right section of Figure 12

Instruction Manual
AGS-LED
858 LED Series
Sizes 1, 2, 3, 4 and 5

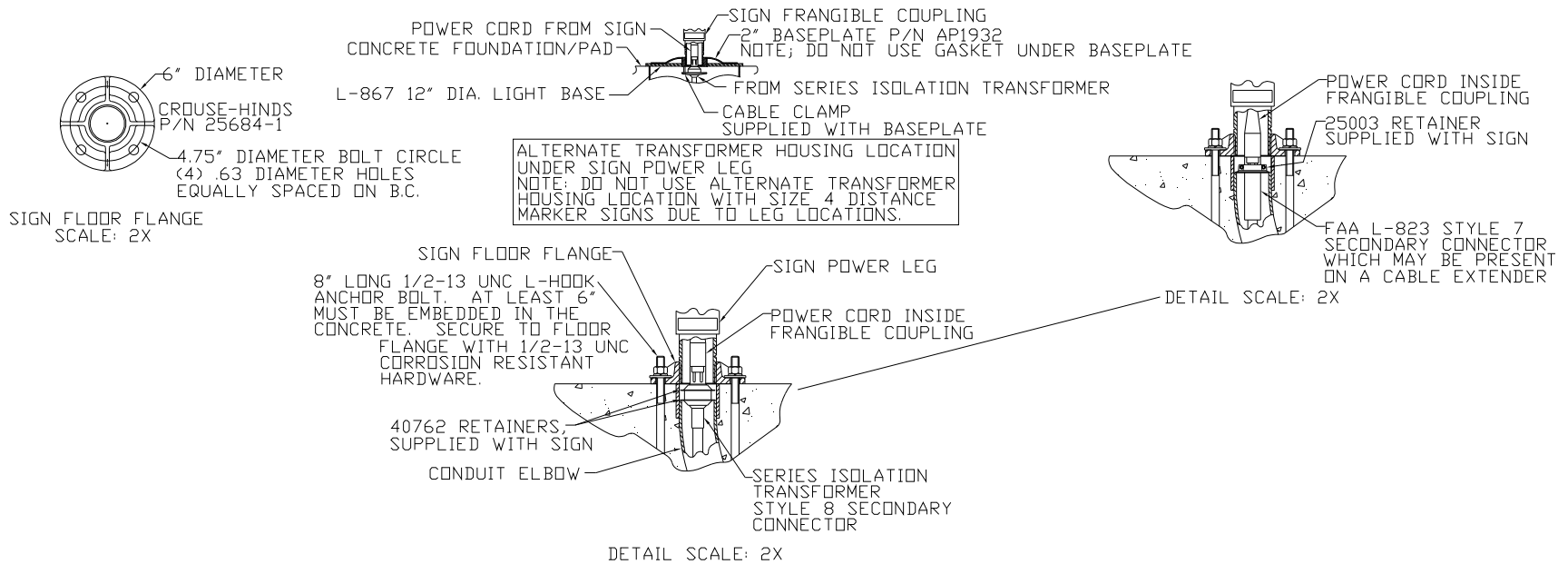
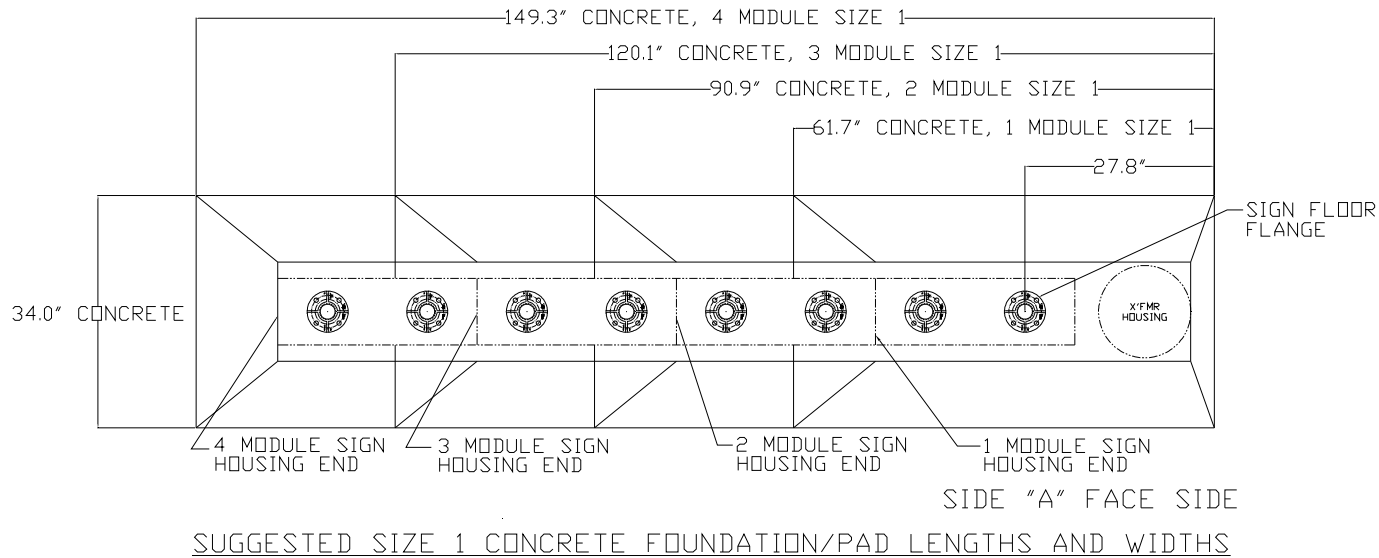

Figure 12c. Expanded top section of Figure 12

Instruction Manual
AGS-LED
858 LED Series
Sizes 1, 2, 3, 4 and 5



TAXIWAY OR RUNWAY
PAVEMENT

Figure 13. Concrete Foundation/Pad configurations, Size 1

Instruction Manual
AGS-LED
858 LED Series
Sizes 1, 2, 3, 4 and 5

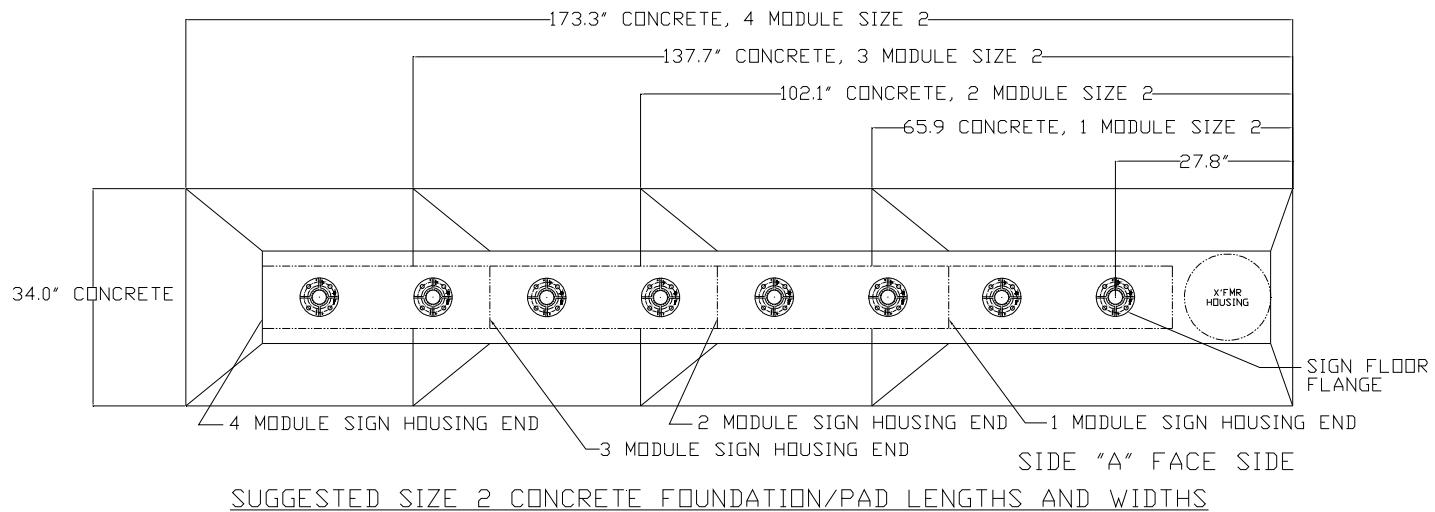
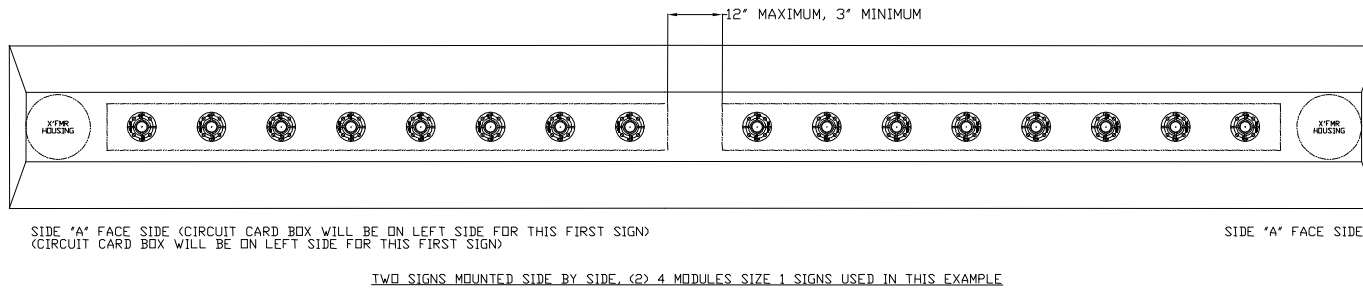

Figure 14. Concrete Foundation/Pad configurations, Size 2

Instruction Manual
AGS-LED
858 LED Series
Sizes 1, 2, 3, 4 and 5



TAXIWAY OR RUNWAY
PAVEMENT

Figure 15. Concrete Foundation/Pad configurations: Two 4-Module Signs, Side by Side

NOTE, IF 3 SIGNS ARE USED IN AN ARRAY, MAKE SEPARATION DISTANCE 12 INCHES TO ALLOW CIRCUIT CARD BOX DOOR TO OPEN IN THIS SPACE WHEN ANOTHER CIRCUIT CARD BOX IS MOUNTED IN THIS SAME SPACE UTILIZED ON ADJACENT SIGN. THIS WILL ALLOW THIS SEPARATION DISTANCE TO REMAIN WITHIN THE FAA SPECIFICATION.

Instruction Manual
AGS-LED
858 LED Series
Sizes 1, 2, 3, 4 and 5

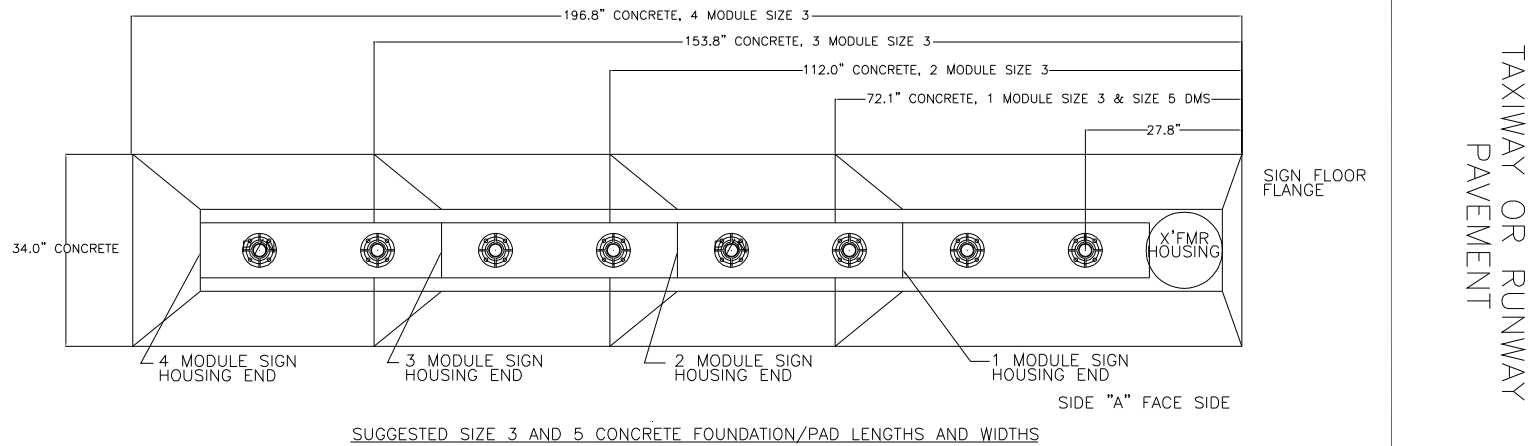
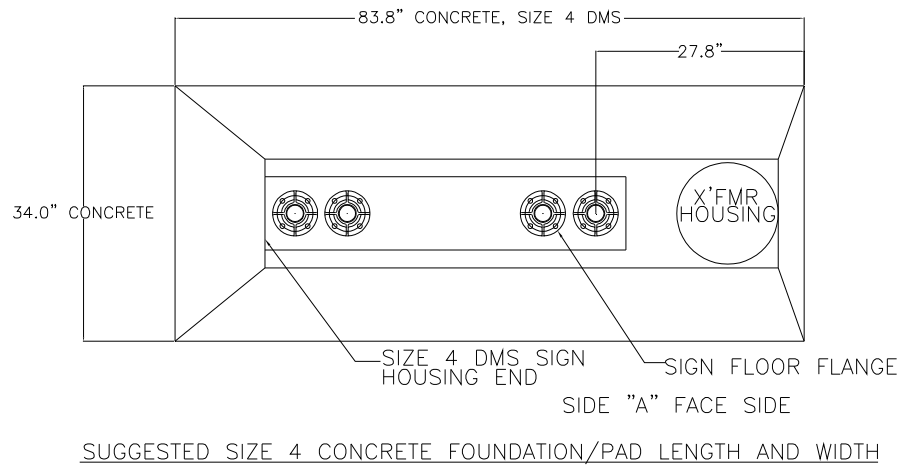

Figure 16. Sizes 3, & 5 Concrete Foundation/Pad Configurations

Instruction Manual
AGS-LED
858 LED Series
Sizes 1, 2, 3, 4 and 5



TAXIWAY OR RUNWAY
PAVEMENT

Figure 17. Size 4 Concrete Foundation/Pad Configurations

Instruction Manual
AGS-LED
858 LED Series
Sizes 1, 2, 3, 4 and 5

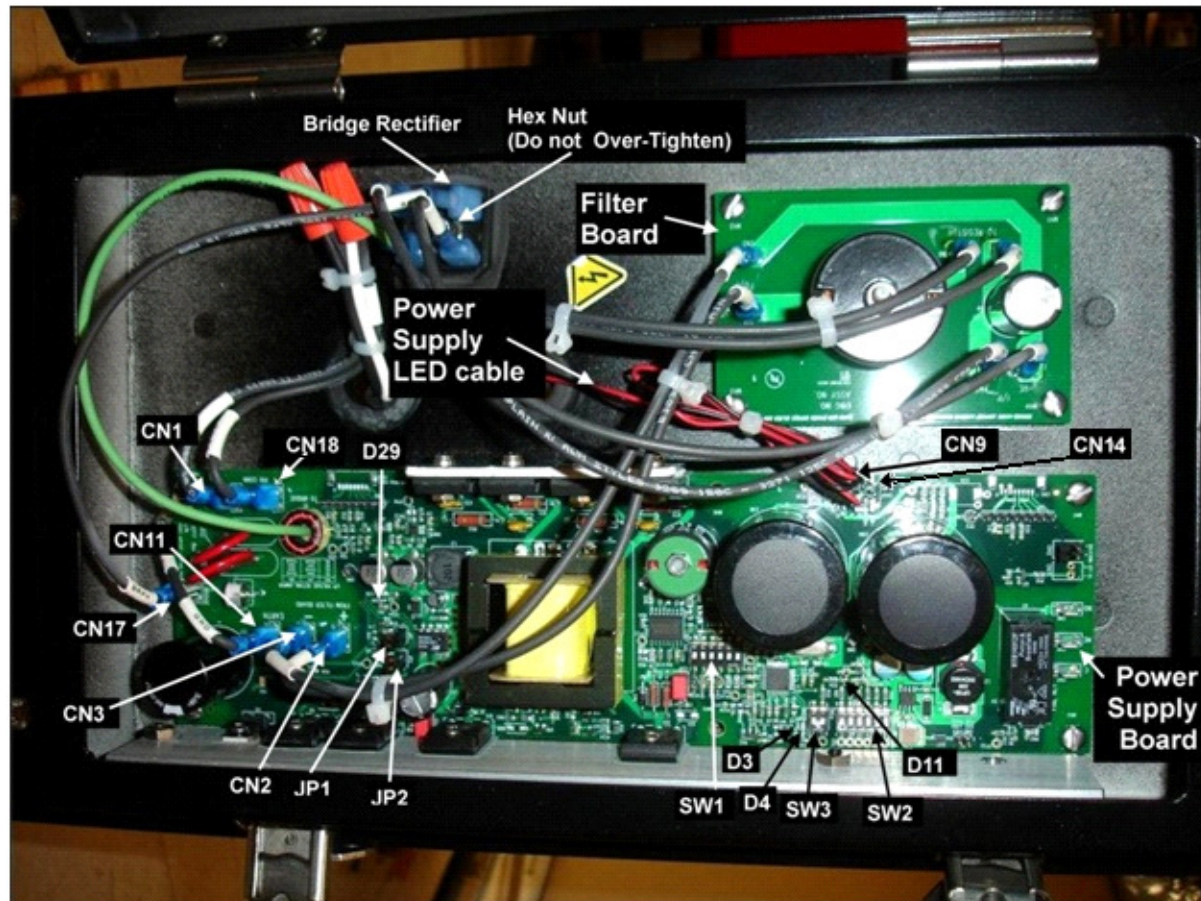

Figure 18. Power Supply Box

Instruction Manual
AGS-LED
858 LED Series
Sizes 1, 2, 3, 4 and 5

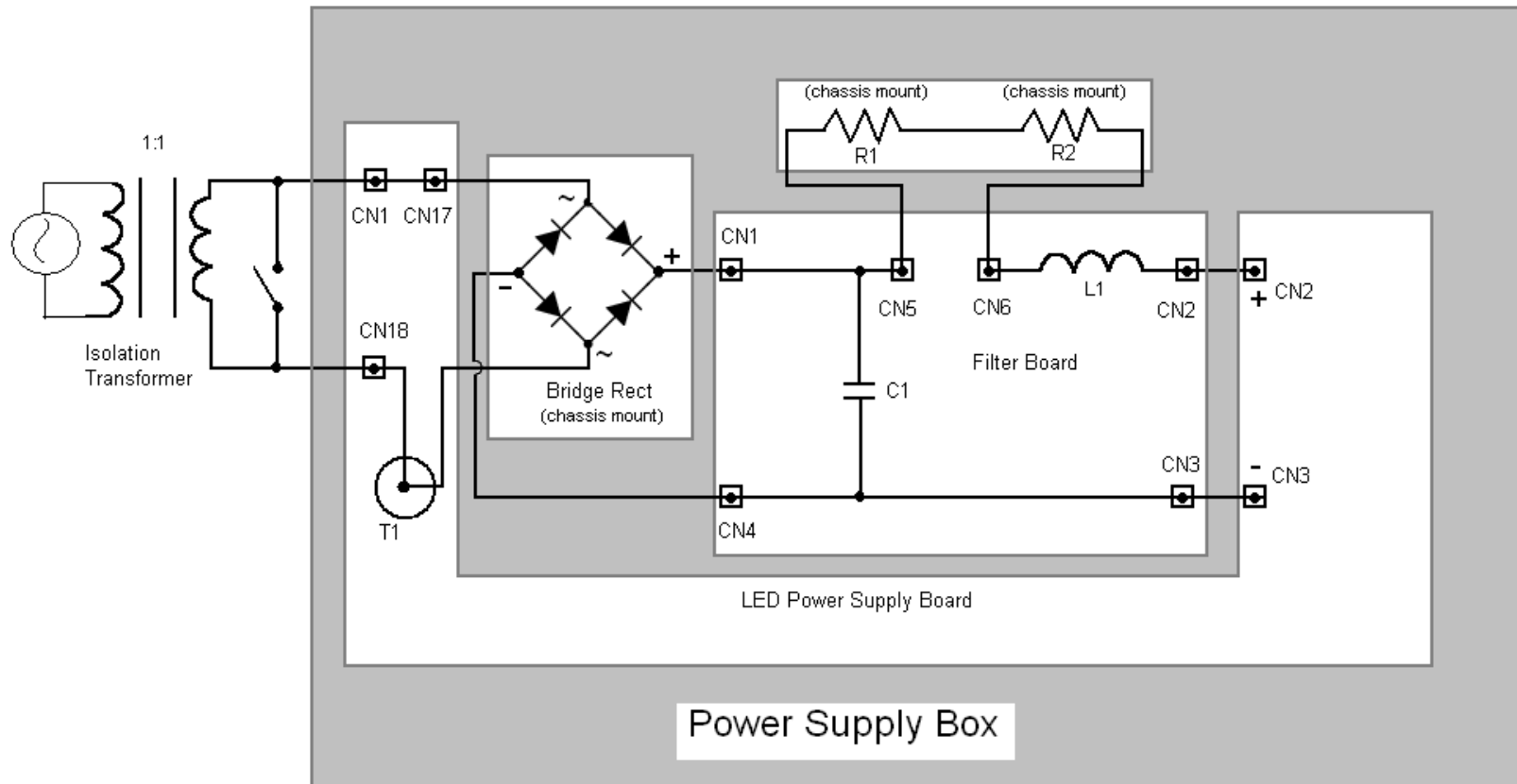
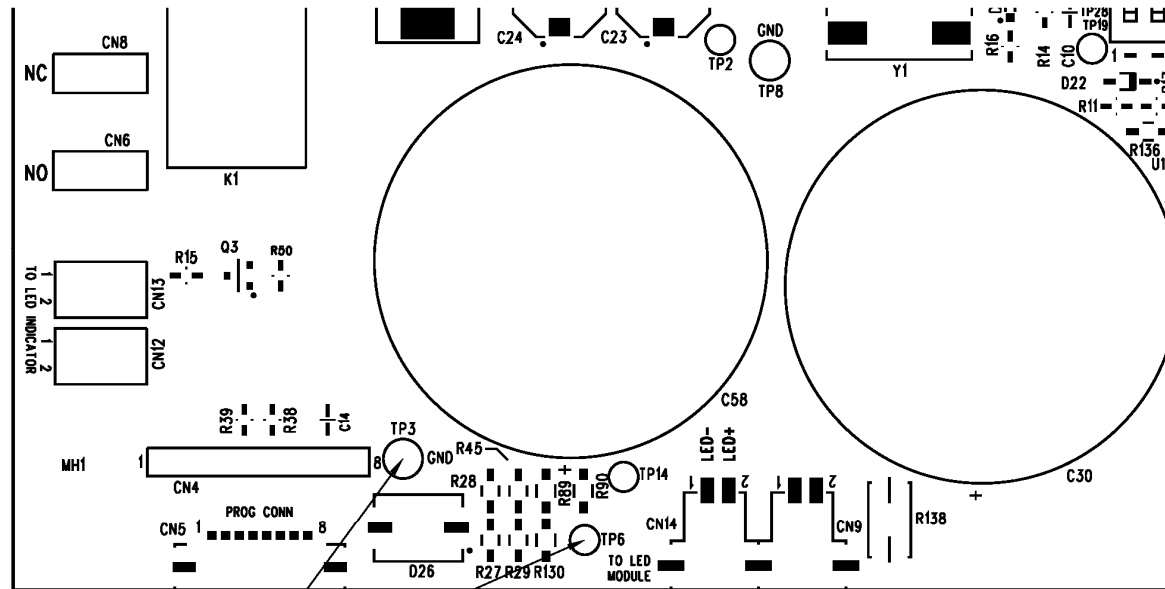

Figure 21. Power Supply Wiring Diagram

Instruction Manual
AGS-LED
858 LED Series
Sizes 1, 2, 3, 4 and 5



MEASURE DC VOLTAGE AT THIS LOCATION.
MAXIMUM VOLTAGE COULD BE 290 DCV,
SAFE TO HANDLE AT LESS THAN 30 DC VOLTS.

Figure 22. Checking the Power Supply Output Voltage After Turn-Off.

Instruction Manual
AGS-LED
858 LED Series
Sizes 1, 2, 3, 4 and 5

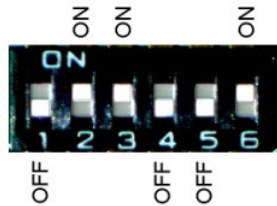

Example of Dip Switch ON/OFF Positions

L858 AGS		Output Current Setting			Input voltage configuration		Output LED Configuration				Calibration Mode/ Normal Operation	Ferro CCR	
Size	#Mods	SW1-4	SW1-5	SW1-6	SW2-1	SW2-2	SW2-3	SW2-4	SW2-5	SW2-6	SW3-1	JP1	JP2
1	1	x	ON	OFF	ON	ON	ON	ON	ON	ON	ON/OFF	Close	Close
1	2	x	ON	OFF	ON	ON	ON	ON	ON	OFF	ON/OFF	Close	Close
1	3	x	ON	OFF	ON	ON	ON	ON	OFF	ON	ON/OFF	Close	Close
1	4	x	ON	OFF	ON	OFF	ON	ON	OFF	OFF	ON/OFF	Close	Open
2	1	x	x	ON	ON	ON	ON	OFF	ON	ON	ON/OFF	Close	Close
2	2	x	x	ON	ON	ON	ON	OFF	ON	OFF	ON/OFF	Close	Close
2	3	x	x	ON	ON	OFF	ON	OFF	OFF	ON	ON/OFF	Close	Open
2	4	x	x	ON	ON	OFF	ON	OFF	OFF	OFF	ON/OFF	Close	Open
3	1	x	ON	OFF	ON	ON	OFF	ON	ON	ON	ON/OFF	Close	Close
3	2	x	ON	OFF	ON	OFF	OFF	ON	ON	OFF	ON/OFF	Close	Open
3	3	x	ON	OFF	ON	OFF	OFF	ON	OFF	ON	ON/OFF	Close	Open
3	4	x	ON	OFF	OFF	OFF	OFF	ON	OFF	OFF	ON/OFF	Open	Open
4	2	ON	OFF	OFF	ON	OFF	OFF	OFF	ON	ON	ON/OFF	Close	Open

Table 1. Power Supply Switch and Jumper Selection (FERRO CCR)

Instruction Manual
AGS-LED
858 LED Series
Sizes 1, 2, 3, 4 and 5

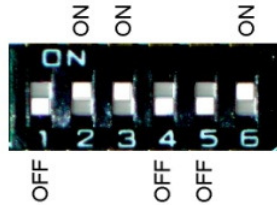

Example of Dip Switch ON/OFF Positions

L858 AGS		Output Current Setting			Input voltage configuration		Output LED Configuration				Calibration Mode/ Normal Operation	Series CCR	
Size	#Mods	SW1-4	SW1-5	SW1-6	SW2-1	SW2-2	SW2-3	SW2-4	SW2-5	SW2-6	SW3-1	JP1	JP2
1	1	x	ON	OFF	ON	ON	ON	ON	ON	ON	ON/OFF	Close	Close
1	2	x	ON	OFF	ON	ON	ON	ON	ON	OFF	ON/OFF	Close	Close
1	3	x	ON	OFF	ON	ON	ON	ON	OFF	ON	ON/OFF	Close	Close
1	4	x	ON	OFF	ON	OFF	ON	ON	OFF	OFF	ON/OFF	Close	Open
2	1	x	x	ON	ON	ON	ON	OFF	ON	ON	ON/OFF	Close	Close
2	2	x	x	ON	ON	ON	ON	OFF	ON	OFF	ON/OFF	Close	Close
2	3	x	x	ON	ON	OFF	ON	OFF	OFF	ON	ON/OFF	Close	Open
2	4	x	x	ON	OFF	OFF	ON	OFF	OFF	OFF	ON/OFF	Open	Open
3	1	x	ON	OFF	ON	ON	OFF	ON	ON	ON	ON/OFF	Close	Close
3	2	x	ON	OFF	ON	OFF	OFF	ON	ON	OFF	ON/OFF	Close	Open
3	3	x	ON	OFF	OFF	OFF	OFF	ON	OFF	ON	ON/OFF	Open	Open
3	4	x	ON	OFF	OFF	OFF	OFF	ON	OFF	OFF	ON/OFF	Open	Open
4	2	ON	OFF	OFF	ON	OFF	OFF	OFF	ON	ON	ON/OFF	Close	Open

Table 2. Power Supply Switch and Jumper Selection (SERIES CCR)

Instruction Manual
AGS-LED
858 LED Series
Sizes 1, 2, 3, 4 and 5

Style	Sign Size	# Modules	CCR type	CCHALP Sign VA (Primary Isolation Xfrmr@ 6.6A)	CCHALP Sign Watts (Primary Isolation Xfrmr @ 6.6A)	CCHALP Power Factor (Primary Isolation Xfrmr)	CCHALP Sign VA (Secondary Isolation Xfrmr@ 6.6A)	CCHALP Sign Watts (Secondary Isolation Xfrmr @ 6.6A)	CCHALP Power Factor (Secondary Isolation Xfrmr)	CCHALP Isolation Transformer Type
2	1	1	Ferro	53	45	0.85	35	29	0.83	65W
2	1	2	Ferro	57	50	0.88	39	34	0.86	65W
2	1	3	Ferro	64	54	0.84	48	41	0.84	100W
2	1	4	Ferro	67	58	0.87	52	45	0.87	100W
2	2	1	Ferro	51	44	0.86	34	29	0.85	65W
2	2	2	Ferro	58	50	0.87	41	35	0.86	65W
2	2	3	Ferro	62	55	0.88	47	42	0.89	100W
2	2	4	Ferro	68	61	0.89	53	48	0.90	100W
2	3	1	Ferro	57	50	0.88	39	34	0.86	65W
2	3	2	Ferro	67	58	0.87	52	45	0.87	100W
2	3	3	Ferro	77	69	0.90	62	56	0.90	100W
2	3	4	Ferro	102	88	0.86	77	68	0.89	200W
2	4	2	Ferro	74	66	0.90	60	53	0.88	100W

Table 3. AGS 858 LED Sign Style 2 VA Load & Matching Isolation Transformer (Ferro)

Instruction Manual
AGS-LED
858 LED Series
Sizes 1, 2, 3, 4 and 5

Style	Sign Size	# Modules	CCR type	CCHALP Sign VA (Primary Isolation Xfrmr@ 6.6A)	CCHALP Sign Watts (Primary Isolation Xfrmr @ 6.6A)	CCHALP Power Factor (Primary Isolation Xfrmr)	CCHALP Sign VA (Secondary Isolation Xfrmr@ 6.6A)	CCHALP Sign Watts (Secondary Isolation Xfrmr @ 6.6A)	CCHALP Power Factor (Secondary Isolation Xfrmr)	CCHALP Isolation Transformer Type
3	1	1	Ferro	53	45	0.85	35	29	0.83	65W
3	1	2	Ferro	57	50	0.88	39	34	0.86	65W
3	1	3	Ferro	64	54	0.84	48	41	0.84	100W
3	1	4	Ferro	67	58	0.87	52	45	0.87	100W
3	2	1	Ferro	51	44	0.86	34	29	0.85	65W
3	2	2	Ferro	58	50	0.87	41	35	0.86	65W
3	2	3	Ferro	62	55	0.88	47	42	0.89	100W
3	2	4	Ferro	68	61	0.89	53	48	0.90	100W
3	3	1	Ferro	57	50	0.88	39	34	0.86	65W
3	3	2	Ferro	67	58	0.87	52	45	0.87	100W
3	3	3	Ferro	77	69	0.90	62	56	0.90	100W
3	3	4	Ferro	102	88	0.86	77	68	0.89	200W
3	4	2	Ferro	74	66	0.90	60	53	0.88	100W

Table 4. AGS 858 LED Sign Style 3 VA Load & Matching Isolation Transformer (Ferro)

Instruction Manual
AGS-LED
858 LED Series
Sizes 1, 2, 3, 4 and 5

Style	Sign Size	# Modules	CCR type	CCHALP Sign VA (Primary Isolation Xfrmr@ 5.5A)	CCHALP Sign Watts (Primary Isolation Xfrmr @5.5A)	CCHALP Power Factor (Primary Isolation Xfrmr)	CCHALP Sign VA (Secondary Isolation Xfrmr@ 5.5A)	CCHALP Sign Watts (Secondary Isolation Xfrmr @ 5.5A)	CCHALP Power Factor (Secondary Isolation Xfrmr)	CCHALP Isolation Transformer Type
5	1	1	Ferro	42	36	0.86	29	25	0.84	65W
5	1	2	Ferro	47	42	0.88	34	30	0.88	65W
5	1	3	Ferro	51	46	0.89	39	35	0.90	65W
5	1	4	Ferro	56	51	0.91	45	41	0.91	65W
5	2	1	Ferro	43	38	0.87	30	26	0.86	65W
5	2	2	Ferro	49	44	0.89	35	32	0.89	65W
5	2	3	Ferro	54	49	0.90	43	39	0.89	100W
5	2	4	Ferro	60	55	0.91	49	44	0.91	100W
5	3	1	Ferro	47	42	0.88	34	30	0.88	65W
5	3	2	Ferro	56	51	0.91	45	41	0.91	65W
5	3	3	Ferro	68	62	0.91	56	52	0.92	100W
5	3	4	Ferro	82	75	0.91	70	64	0.91	100W
5	4	2	Ferro	43	38	0.87	30	26	0.86	65W

Table 5. AGS 858 LED Sign Style 5 VA Load & Matching Isolation Transformer (Ferro)

Instruction Manual
AGS-LED
858 LED Series
Sizes 1, 2, 3, 4 and 5

Style	Sign Size	# Modules	CCR type	Sign VA (Primary Isolation Xfrmr@ 6.6A)	Sign Watts (Primary Isolation Xfrmr @ 6.6A)	Power Factor (Primary Isolation Xfrmr)	Sign VA (Secondary Isolation Xfrmr@ 6.6A)	Sign Watts (Secondary Isolation Xfrmr @ 6.6A)	Power Factor (Secondary Isolation Xfrmr)	Isolation Transformer Type
2	1	1	Series	180	87	0.49	87	67	0.77	200W
2	1	2	Series	181	90	0.50	89	70	0.78	200W
2	1	3	Series	182	92	0.50	92	71	0.78	200W
2	1	4	Series	183	93	0.51	94	73	0.78	200W
2	2	1	Series	180	88	0.49	41	37	0.89	200W
2	2	2	Series	181	91	0.50	90	70	0.78	200W
2	2	3	Series	182	93	0.51	93	73	0.79	200W
2	2	4	Series	183	94	0.51	95	75	0.79	200W
2	3	1	Series	181	90	0.50	89	70	0.78	200W
2	3	2	Series	183	93	0.51	94	73	0.78	200W
2	3	3	Series	186	98	0.53	99	77	0.78	200W
2	3	4	Series	277	101	0.36	102	82	0.80	300W
2	4	2	Series	185	97	0.52	97	77	0.79	200W

Table 6. AGS 858 LED Sign Style 2 VA Load & Matching Isolation Transformer (Series)

Instruction Manual
AGS-LED
858 LED Series
Sizes 1, 2, 3, 4 and 5

Style	Sign Size	# Modules	CCR type	Sign VA (Primary Isolation Xfrmr@ 6.6A)	Sign Watts (Primary Isolation Xfrmr @ 6.6A)	Power Factor (Primary Isolation Xfrmr)	Sign VA (Secondary Isolation Xfrmr@ 6.6A)	Sign Watts (Secondary Isolation Xfrmr @ 6.6A)	Power Factor (Secondary Isolation Xfrmr)	Isolation Transformer Type
3	1	1	Series	180	87	0.49	87	67	0.77	200W
3	1	2	Series	181	90	0.50	89	70	0.78	200W
3	1	3	Series	182	92	0.50	92	71	0.78	200W
3	1	4	Series	183	93	0.51	94	73	0.78	200W
3	2	1	Series	180	88	0.49	87	68	0.78	200W
3	2	2	Series	181	91	0.50	90	70	0.78	200W
3	2	3	Series	182	93	0.51	93	73	0.79	200W
3	2	4	Series	183	94	0.51	95	75	0.79	200W
3	3	1	Series	181	90	0.50	89	70	0.78	200W
3	3	2	Series	183	93	0.51	94	73	0.78	200W
3	3	3	Series	186	98	0.53	99	77	0.78	200W
3	3	4	Series	277	101	0.36	102	82	0.80	300W
3	4	2	Series	185	97	0.52	97	77	0.79	200W

Table 7. AGS 858 LED Sign Style 3 VA Load & Matching Isolation Transformer (Series)

Instruction Manual
AGS-LED
858 LED Series
Sizes 1, 2, 3, 4 and 5

Style	Sign Size	# Modules	CCR type	Sign VA (Primary Isolation Xfrmr@ 5.5A)	Sign Watts (Primary Isolation Xfrmr @ 5.5A)	Power Factor (Primary Isolation Xfrmr)	Sign VA (Secondary Isolation Xfrmr@ 5.5A)	Sign Watts (Secondary Isolation Xfrmr @ 5.5A)	Power Factor (Secondary Isolation Xfrmr)	Isolation Transformer Type
5	1	1	Series	108	56	0.52	54	46	0.85	200W
5	1	2	Series	109	58	0.53	55	47	0.86	200W
5	1	3	Series	111	60	0.54	57	49	0.85	200W
5	1	4	Series	112	63	0.56	60	52	0.87	200W
5	2	1	Series	110	56	0.51	53	45	0.85	200W
5	2	2	Series	110	59	0.53	55	48	0.87	200W
5	2	3	Series	111	61	0.56	59	51	0.86	200W
5	2	4	Series	112	65	0.58	62	54	0.86	200W
5	3	1	Series	109	58	0.53	55	47	0.86	200W
5	3	2	Series	112	63	0.56	60	52	0.87	200W
5	3	3	Series	116	70	0.61	67	59	0.88	200W
5	3	4	Series	121	78	0.65	76	66	0.88	200W
5	4	2	Series	115	69	0.60	66	57	0.87	200W

Table 8. AGS 858 LED Sign Style 5 VA Load & Matching Isolation Transformer (Series)

Instruction Manual
AGS-LED
858 LED Series
Sizes 1, 2, 3, 4 and 5

Regulator Setting	Current Range (A, RMS)
B10	4.7-4.9 (4.80 nominal)
B30	5.3-5.7 (5.50 nominal)
B100	6.4-6.7(6.60 nominal)

Table 9. Style 2 - Three step regulator currents

Regulator Setting	Current Range (A, RMS)
B1	2.7-2.9(2.80 nominal)
B2	3.3-3.5(3.4 nominal)
B3	4.0-4.2(4.10 nominal)
B4	5.0-5.4(5.20 nominal)
B5	6.4-6.7(6.60 nominal)

Table 10. Style 3 - Five step regulator currents

Regulator Setting	Current Range (A, RMS)
Fixed	5.4-5.6(5.50 nominal)

Table 11. Style 5 – Fixed regulator current

Note: See page vi for a list of meters that would be suitable for these measurements.

Instruction Manual
AGS-LED
858 LED Series
Sizes 1, 2, 3, 4 and 5

D4 (Red)	D7 (Red)	D11 (Green)	D29 (Green)	Fault
ON	ON	ON	ON	Output open circuit
ON	OFF	ON	ON	Output Voltage is less than or equal to 75% of Calibrated Output Voltage or Output Voltage is greater than or equal to 125% of Calibrated Output Voltage.
OFF	ON	ON	ON	Input current < 2.5A or Input current > 6.7A
OFF	OFF	ON	OFF	+3.3 Volt Supply Failure
OFF	OFF	OFF	OFF	+15 Volt Supply and/or +3.3 Volt Supply Failure (assumes the main AC power is applied to the power supply board)

Table 12. Power Supply Faults

Instruction Manual
AGS-LED
858 LED Series
Sizes 1, 2, 3, 4 and 5

DESCRIPTION	PART NUMBER	USED ON
Frangible Coupling	62245-1 62245-2 62245-3 62245-4	Size 1 Size 2 Size 3 & 5 Size 4
Power Supply PCB (located inside circuit box)	62277	All Sizes
Heatsink/LED Assembly (located inside sign housing)	62288	All Sizes
Filter PCB (located inside circuit box)	62279	All Sizes
Bridge Rectifier and Thermal Pad Replacement Kit (located inside circuit box)	62314	All Sizes
Sign Face Panel (w/Legend)	62290-X	Contact Factory with legend information
Sign Panel, Black	60668-X	Contact Factory with sign size and number of modules
LED Array to LED array input wire, white	62278-1(48") 62278-2(12") 62278-3(6")	All sizes All sizes except size 3 1,2,3,4 module and size 5 All sizes except size 1 & 2 1,2,3,4 module and size 4
Last LED array to power supply PCB CN9, return wire, black	62317-1(67") 62317-2(85") 62317-3(105") 62317-4(92") 62317-5(120") 62317-6(144") 62317-7(131") 62317-8(162") 62317-9(192") 62317-10(158") 62317-11(196") 62317-12(232") 62317-13(118")	Size 1, 1 module Size 2, 1 module Size 3 & 5, 1 module Size 1, 2 module Size 2, 2 module Size 3, 2 module Size 1, 3 module Size 2, 3 module Size 3, 3 module Size 1, 4 module Size 2, 4 module Size 3, 4 module Size 4 DMS

Table 13. Parts List

Instruction Manual
AGS-LED
858 LED Series
Sizes 1, 2, 3, 4 and 5

Sign Size/#Mod	Force in Newtons	Force in Lbs
Size 1, 1module	3,080	692
Size 1, 2modules	6,186	1,391
Size 1, 3modules	8,984	2,020
Size 1, 4modules	12,531	2,817
Size 2, 1module	4,773	1,073
Size 2, 2modules	9,587	2,155
Size 2, 3modules	14,442	3,247
Size 2, 4modules	19,420	4,367
Size 3&5, 1module	7,107	1,598
Size 3, 2modules	13,657	3,070
Size 3, 3modules	20,573	4,625
Size 3, 4modules	27,664	6,220
Size 4 DMS	11,582	2,604

Table 14. Estimated max sustained force on the sign body (Does not include safety margin)

Based on:
$$C_D = \frac{F_D}{1/2 \rho V^2 A}$$

V = 89,408 M/S

p = 1.2047 Kg/ M³ (@ 20°C dry)

C_D = 1.16 for 1 module & size 4 and 5 DMS, 1.165 for 2 module, 1.17 for 3 module, and 1.18 for 4 module.