

CENTRAL PNEUMATIC.



1/4" Air Die Grinder Kit

Model 53177

Assembly and Operating Instructions



3491 Mission Oaks Blvd., Camarillo, CA 93011

Copyright © 1998 by Harbor Freight Tools. All rights reserved. No portion of this manual or any artwork contained herein may be reproduced in any shape or form without the express written consent of Harbor Freight Tools.

For technical questions and replacement parts, please call 1-800-444-3353

Specifications

Includes: 5 Piece Mounted Stones,
1 Piece Nipple, and 2 Double
End 4-5/8" x .100" Wrenches
Inlet: 1/4" NPT Female
Rear Exhaust
PSI: 90
Inline Body Design
RPM: 22,000 (No Load)
CFM: 3
Recommended Hose: 3/8"

Save This Manual

You will need the manual for the safety warnings and precautions, assembly instructions, operating and maintenance procedures, parts list and diagram. Keep your invoice with this manual. Write the invoice number on the inside of the front cover. Keep the manual and invoice in a safe and dry place for future reference.

Safety Warnings and Precautions

WARNING: When using tool, basic safety precautions should always be followed to reduce the risk of personal injury and damage to equipment.

Read all instructions before using this tool!

1. **Keep work area clean.** Cluttered areas invite injuries.
2. **Observe work area conditions.** Do not use machines or power tools in damp or wet locations. Don't expose to rain. Keep work area well lighted. Do not use electrically powered tools in the presence of flammable gases or liquids.
3. **Keep children away.** Children must never be allowed in the work area. Do not let them handle machines, tools, or extension cords.
4. **Store idle equipment.** When not in use, tools must be stored in a dry location to inhibit rust. Always lock up tools and keep out of reach of children.
5. **Do not force tool.** It will do the job better and more safely at the rate for which it was intended. Do not use inappropriate attachments in an attempt to exceed the tool capacity.
6. **Use the right tool for the job.** Do not attempt to force a small tool or attachment to do the work of a larger industrial tool. Do not use a tool for a purpose for which it was not intended.

7. **Dress properly.** Do not wear loose clothing or jewelry as they can be caught in moving parts. Protective, electrically non-conductive clothes and non-skid footwear are recommended when working. Wear restrictive hair covering to contain long hair.
8. **Use eye and ear protection.** Always wear ANSI approved impact safety goggles. Wear a full face shield if you are producing metal filings or wood chips. Wear an ANSI approved dust mask or respirator when working around metal, wood, and chemical dusts and mists.
9. **Do not overreach.** Keep proper footing and balance at all times. Do not reach over or across running machines.
10. **Maintain tools with care.** Keep tools sharp and clean for better and safer performance. Follow instructions for lubricating and changing accessories. Inspect tool cords periodically and, if damaged, have them repaired by an authorized technician. The handles must be kept clean, dry, and free from oil and grease at all times.
11. **Disconnect power.** Unplug when not in use. Do not yank power cord from the receptacle. Do not carry tools by the cord.
12. **Remove adjusting keys and wrenches.** Check that keys and adjusting wrenches are removed from the tool or machine work surface before plugging it in.
13. **Avoid unintentional starting.** Be sure the switch is in the Off position when not in use and before plugging in. Do not carry any tool with your finger on the trigger, whether it is plugged in or not.
14. **Stay alert.** Watch what you are doing, use common sense. Do not operate any tool when you are tired.
15. **Check for damaged parts.** Before using any tool, any part that appears damaged should be carefully checked to determine that it will operate properly and perform its intended function. Check for alignment and binding of moving parts; any broken parts or mounting fixtures; and any other condition that may affect proper operation. Any part that is damaged should be properly repaired or replaced by a qualified technician. Do not use the tool if any switch does not turn On and Off properly.
16. **Guard against electric shock.** Prevent body contact with grounded surfaces such as pipes, radiators, ranges, and refrigerator enclosures.
17. **Replacement parts and accessories.** When servicing, use only identical replacement parts. Use of any other parts will void the warranty. Only use accessories intended for use with this tool. Approved accessories are available from Harbor Freight Tools.
18. **Do not operate tool if under the influence of alcohol or drugs.** Read warning labels on prescriptions to determine if your judgment or reflexes are impaired while taking drugs. If there is any doubt, do not operate the tool.

Unpacking

When unpacking, check the parts diagram and part number listing on page 6 to make sure all parts are included. If any parts are missing or damaged, please call Harbor Freight Tools at the number on the cover of this manual as soon as possible.

Your Air Die Grinder comes pre-assembled. To complete preparations for use, follow the steps shown below. Part numbers shown below identify parts shown on the part number listing on page 6.

Air Connection

1. You will need a Union fitting (sold separately) before you can connect your Air Die Grinder to an air compressor.
2. Attach the Union fitting to the Inlet (#1) and tighten with a wrench.
3. Attach an Air Coupler (sold separately) to the Union fitting if desired. This is a useful accessory as it allows quick-coupling action when using a variety of tools with the same air compressor.
4. The Air Die Grinder is ready for use.

Operation

Frequent but not excessive, lubrication is required for best performance. Oil added through the airline connection will lubricate internal parts. An automatic airline oiler is recommended but oil may be added manually before every operation or after about 1 hour of continuous use. Only a few drops of oil at a time are necessary. Too much oil will collect inside the tool and be blown out during the exhaust cycle. **ONLY USE PNEUMATIC TOOL OIL.** Do not use detergent oil or additives as these lubricants will cause accelerated wear to the seals in the tool.

Dirt and water in the air supply are major causes of pneumatic tool wear. Use a filter/oiler for better performance and longer life. The filter must have adequate flow capacity for the specific application. Consult the manufacturer's instructions for proper maintenance of your filter.

The connector on the tool must not hold pressure when the air supply is disconnected. If the wrong fitting is used, the tool can remain charged with air after being disconnected.

Grinding Attachment Installation

- Step 1. Select the Grinding Mounted Stone attachment appropriate for your needs.
- Step 2. Use the Spanner (#25) to hold the Spindle (#22) in place, while using the other Spanner (#26) to loosen and remove the Collet Nut (#24).
- Step 3: Insert the shaft of the Grinding Mounted Stone into the Collet (#23). Reassemble the Collet Nut on the Spindle. Use both Spanners to tighten.

Using the Die Grinder

1. Step 1: Set the compressor's pressure regulator to 90 PSI. Do not set the compressor's outlet regulator over 90 PSI.
2. Connect the Die Grinder to the air compressor's hose. If leaking is detected, disconnect the air hose and repair before use.

3. Place the material you will be grinding into a vise or otherwise clamp the object so that it will not move around when you use the Die Grinder. Make sure you still have unobstructed access to the area you will be grinding.

Warning: Always wear protective gloves, goggles and a dust mask when operating this tool.

4. Grip the Die Grinder firmly with your hand. Press the Trigger (#4) to start the Die Grinder before you touch the Mounted Stone attachment to the surface. The Die Grinder's speed is variable. Vary the speed by adjusting pressure on the Trigger.

5. Allow the Mounted Stone attachment to do the work. Do not use excessive force to press the attachment into the surface that is being grinded. If the Die Grinder stalls while being operated, immediately release the Trigger and pull the Die Grinder away from the surface.

Removal of Mounted Stone Attachments

1. With the Die Grinder disconnected from the compressor's hose, use the Spanners to again loosen the Collet Nut. Remove the Collet Nut and take out the Mounted Stone attachment. Put on the desired new Mounted Stone attachment, reassemble the Collet Nut, and tighten using both Spanners.

Maintenance

The Air Die Grinder is best operated with an airline oiler. If you are using the Air Die Grinder without an airline oiler, perform the following maintenance:

Disconnect the Impact Wrench from the air hose. Apply a few drops of pneumatic tool oil through the air line before each use, or after every hour if used continuously. Apply a few drops of oil to the Trigger mechanism. Work the Trigger a few times to lubricate.

Note: Do not use detergent oil or additives as these lubricants will cause accelerated wear to the tool's seals.

Parts Diagram

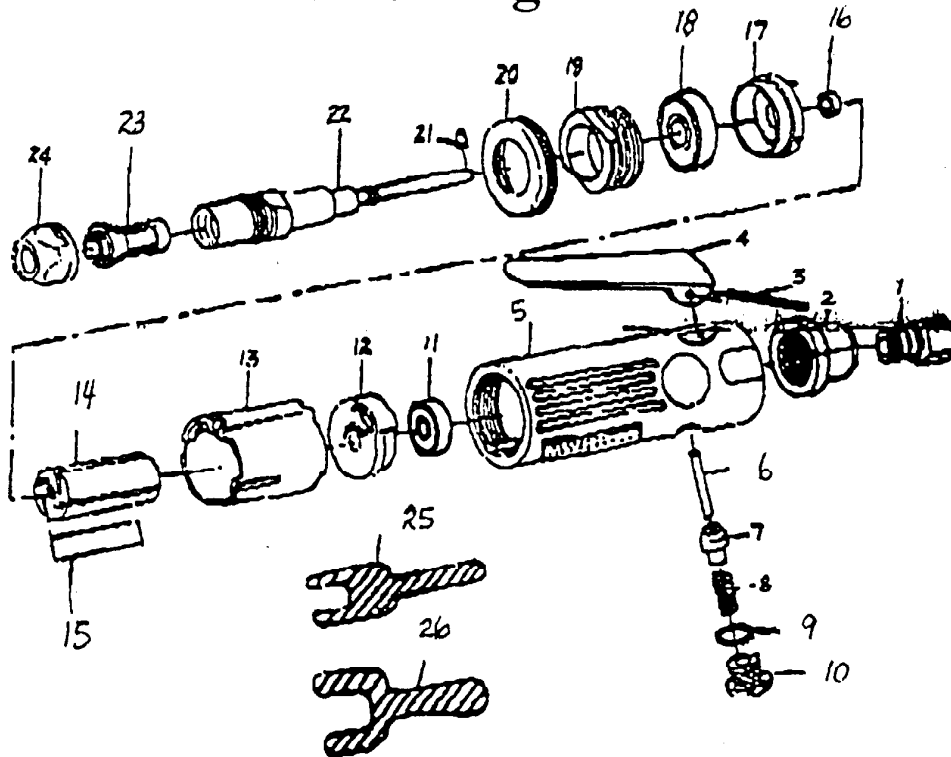

Mounted Stones - Grit #60

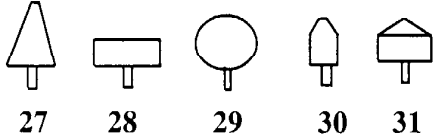

Part Number Listing

Part #	Description	Qty	Part #	Description	Qty
1	Inlet	1	17	Front Plate	1
2	Exhaust Deflector	1	18	Ball Bearing	1
3	Pin	1	19	Nut	1
4	Trigger	1	20	Cap	1
5	Housing	1	21	Washer	1
6	Valve Pin	1	22	Spindle	1
7	Valve	1	23	Collet	1
8	Spring	1	24	Collet Nut	1
9	O'Ring	1	25	Spanner	1
10	Valve Screw	1	26	Spanner	1
11	Ball Bearing	1	27	Mounted Stone	1
12	Rear Plate	1	28	Mounted Stone	1
13	Cylinder	1	29	Mounted Stone	1
14	Rotor	1	30	Mounted Stone	1
15	Rotor Blade	4	31	Mounted Stone	1
16	Bearing Spacer	1			