

Grizzly *Industrial, Inc.*®

SLIMLINE BENCH GRINDER

MODEL H4378/H4379

INSTRUCTION MANUAL

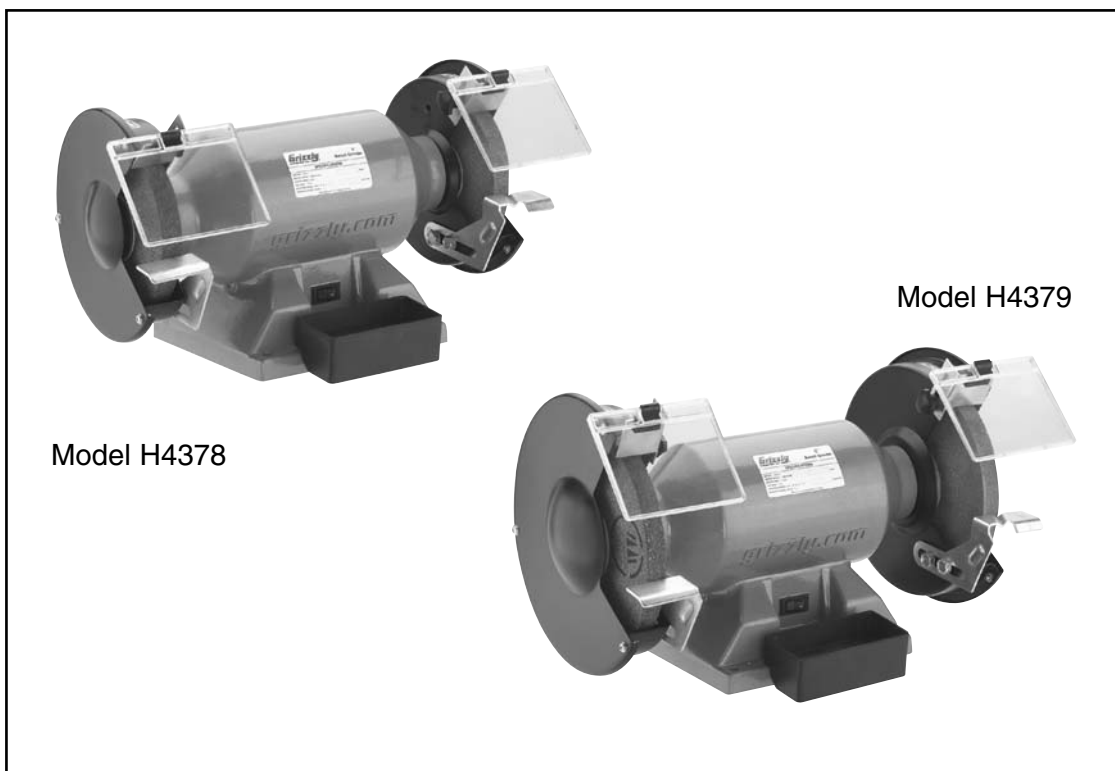

COPYRIGHT © APRIL, 2002 BY GRIZZLY INDUSTRIAL, INC.
**WARNING: NO PORTION OF THIS MANUAL MAY BE REPRODUCED IN ANY SHAPE
OR FORM WITHOUT THE WRITTEN APPROVAL OF GRIZZLY INDUSTRIAL, INC.**
PRINTED IN CHINA.

ONLINE MANUAL DISCLAIMER

THE INFORMATION IN THIS MANUAL REPRESENTS THE CONFIGURATION OF THE MACHINE AS IT IS CURRENTLY BEING SHIPPED. THE MACHINE CONFIGURATION CAN CHANGE AS PRODUCT IMPROVEMENTS ARE INCORPORATED. IF YOU OWN AN EARLIER VERSION OF THE MACHINE, THIS MANUAL MAY NOT EXACTLY DEPICT YOUR MACHINE. CONTACT CUSTOMER SERVICE IF YOU HAVE ANY QUESTIONS ABOUT DIFFERENCES. PREVIOUS VERSIONS ARE NOT AVAILABLE ONLINE.

WARNING

Some dust created by power sanding, sawing, grinding, drilling, and other construction activities contains chemicals known to the State of California to cause cancer, birth defects or other reproductive harm. Some examples of these chemicals are:

- Lead from lead-based paints.
- Crystalline silica from bricks, cement, and other masonry products.
- Arsenic and chromium from chemically treated lumber.

Your risk from these exposures varies, depending on how often you do this type of work. To reduce your exposure to these chemicals: work in a well ventilated area, and work with approved safety equipment, such as those dust masks that are specially designed to filter out microscopic particles.

Table Of Contents

	PAGE
1. SAFETY	
SAFETY RULES FOR POWER TOOLS	2-3
ADDITIONAL SAFETY INSTRUCTIONS FOR GRINDERS	4
2. CIRCUIT REQUIREMENTS	
110V OPERATION	5
EXTENSION CORDS	5
GROUNDING	5
3. INTRODUCTION	
COMMENTARY	6
4. ASSEMBLY	
UNPACKING	7
PIECE INVENTORY	7
MOUNTING	8
TOOL RESTS	8
EYE SHIELDS	8
5. OPERATIONS	
TEST RUN	9
SAFE GRINDING	10
WHEEL CARE	10
WHEEL SELECTION	11
WHEEL INSPECTION	12
WHEEL MOUNTING	13
6. MAINTENANCE	
GENERAL	14
LUBRICATION	14
GRINDING WHEELS	14
MAINTENANCE NOTES	15
7. CLOSURE	16
TROUBLESHOOTING	17
MACHINE DATA	18-19
PARTS BREAKDOWN AND PARTS LIST	20-21
WARRANTY AND RETURNS	22

SECTION 1: SAFETY

WARNING

For Your Own Safety Read Instruction Manual Before Operating This Equipment

The purpose of safety symbols is to attract your attention to possible hazardous conditions. This manual uses a series of symbols and signal words which are intended to convey the level of importance of the safety messages. The progression of symbols is described below. Remember that safety messages by themselves do not eliminate danger and are not a substitute for proper accident prevention measures.



Indicates an imminently hazardous situation which, if not avoided, **WILL** result in death or serious injury.



Indicates a potentially hazardous situation which, if not avoided, **COULD** result in death or serious injury.



Indicates a potentially hazardous situation which, if not avoided, **MAY** result in minor or moderate injury. It may also be used to alert against unsafe practices.

NOTICE

This symbol is used to alert the user to useful information about proper operation of the equipment.

WARNING

Safety Instructions For Power Tools

1. **KEEP GUARDS IN PLACE** and in working order.
2. **REMOVE ADJUSTING KEYS AND WRENCHES.** Form habit of checking to see that keys and adjusting wrenches are removed from tool before turning on.
3. **KEEP WORK AREA CLEAN.** Cluttered areas and benches invite accidents.
4. **DO NOT USE IN DANGEROUS ENVIRONMENT.** Do not use power tools in damp or wet locations, or where any flammable or noxious fumes may exist. Keep work area well lighted.
5. **KEEP CHILDREN AND VISITORS AWAY.** All children and visitors should be kept at a safe distance from work area.
6. **MAKE WORKSHOP CHILD PROOF** with padlocks, master switches, or by removing starter keys.
7. **DO NOT FORCE TOOL.** It will do the job better and safer at the rate for which it was designed.
8. **USE RIGHT TOOL.** Do not force tool or attachment to do a job for which it was not designed.

WARNING

Safety Instructions For Power Tools

- 9. USE PROPER EXTENSION CORD.** Make sure your extension cord is in good condition. Conductor size should be in accordance with the chart below. The amperage rating should be listed on the motor or tool nameplate. An undersized cord will cause a drop in line voltage resulting in loss of power and overheating. Your extension cord must also contain a ground wire and plug pin. Always repair or replace extension cords if they become damaged.

Minimum Gauge for Extension Cords

AMP RATING	LENGTH		
	25ft	50ft	100ft
0-6	18	16	16
7-10	18	16	14
11-12	16	16	14
13-16	14	12	12
17-20	12	12	10
21-30	10	10	No

- 10. WEAR PROPER APPAREL.** Do not wear loose clothing, gloves, neckties, rings, bracelets, or other jewelry which may get caught in moving parts. Non-slip footwear is recommended. Wear protective hair covering to contain long hair.
- 11. ALWAYS USE SAFETY GLASSES.** Also use face or dust mask if cutting operation is dusty. Everyday eyeglasses only have impact resistant lenses, they are NOT safety glasses.
- 12. SECURE WORK.** Use clamps or a vise to hold work when practical. It is safer than using your hand and frees both hands to operate tool.
- 13. DO NOT OVER-REACH.** Keep proper footing and balance at all times.
- 14. MAINTAIN TOOLS WITH CARE.** Keep tools sharp and clean for best and safest performance. Follow instructions for lubricating and changing accessories.
- 15. USE RECOMMENDED ACCESSORIES.** Consult the owner's manual for recommended accessories. The use of improper accessories may cause risk of injury.

- 16. REDUCE THE RISK OF UNINTENTIONAL STARTING.** On machines with magnetic contact starting switches there is a risk of starting if the machine is bumped or jarred. Always disconnect from power source before adjusting or servicing. Make sure switch is in OFF position before reconnecting.

- 17. MANY WOODWORKING TOOLS CAN "KICKBACK" THE WORKPIECE** toward the operator if not handled properly. Know what conditions can create "kickback" and know how to avoid them. Read the manual accompanying the machine thoroughly.

- 18. CHECK DAMAGED PARTS.** Before further use of the tool, a guard or other part that is damaged should be carefully checked to determine that it will operate properly and perform its intended function. Check for alignment of moving parts, binding of moving parts, breakage of parts, mounting, and any other conditions that may affect its operation. A guard or other part that is damaged should be properly repaired or replaced.

- 19. NEVER LEAVE TOOL RUNNING UNATTENDED. TURN POWER OFF.** Do not leave tool until it comes to a complete stop.

- 20. NEVER OPERATE A MACHINE WHEN TIRED, OR UNDER THE INFLUENCE OF DRUGS OR ALCOHOL.** Full mental alertness is required at all times when running a machine.

- 21. NEVER ALLOW UNSUPERVISED OR UNTRAINED PERSONNEL TO OPERATE THE MACHINE.** Make sure any instructions you give in regards to machine operation are approved, correct, safe, and clearly understood.

- 22. IF AT ANY TIME YOU ARE EXPERIENCING DIFFICULTIES** performing the intended operation, stop using the machine! Then contact our service department or ask a qualified expert how the operation should be performed.

WARNING

Additional Safety Instructions For Grinders

- 1. ALWAYS WEAR EYE PROTECTION!**
- 2. MAKE SURE GRINDER IS SECURED FIRMLY TO A BENCH OR STAND BEFORE USE.** Any “wobbles” must be corrected by shimming or blocking before operation.
- 3. BEFORE MOUNTING A NEW WHEEL, BE SURE WHEEL RPM IS RATED AT AN EQUAL OR HIGHER RPM THAN THE GRINDER.**
- 4. DO NOT GRIND ON THE SIDES OF THE GRINDING WHEELS,** unless they are special wheels designed specifically for this purpose.
- 5. ONLY USE FLANGES THAT ARE INCLUDED WITH THE GRINDER.**
- 6. WEAR AN APPROVED DUST MASK OR RESPIRATOR.** Grinding operations produce dust.
- 7. REPLACE A CRACKED WHEEL IMMEDIATELY.** DO NOT use a grinding wheel that has cracks or flaws. Before using, inspect each wheel. Handle wheels carefully to avoid bumping or dropping.
- 8. DO NOT** stand directly in front of grinding wheels when turning machine on.
- 9. PERFORM** a “ring test” (see page 12) on grinding wheels to ensure that they are safe for use. Always inspect grinding wheels before operation.
- 10. HOLD THE WORKPIECE FIRMLY WHILE GRINDING.**
- 11. DO NOT** allow your hands to come into contact with grinding wheels during operation. Abrasive accessories have the ability to remove a lot of material, including skin, very quickly. However, do not wear gloves while grinding, they may get caught in the grinding wheel.
- 12. KEEP TOOL REST AS CLOSE AS POSSIBLE TO GRINDING WHEEL.**
- 13. NEVER GRIND BY PLACING THE WORKPIECE ON TOP OF THE WHEEL.** The wheel may kick the workpiece toward the operator. Always grind on the downward part of the wheel.

WARNING

To operate this or any power tool safely and efficiently, become as familiar with it as possible. The time you invest before you begin to use your Model H4378/H4379 will be time well spent. **DO NOT** operate this machine until you are completely familiar with the contents of this manual, or serious personal injury may occur.

CAUTION

No list of safety guidelines can be complete. Every shop environment is different. Always consider safety first, as it applies to your individual working conditions. Use this and other machinery with caution and respect. Failure to follow guidelines could result in serious personal injury, damage to equipment or poor work results.

SECTION 2: CIRCUIT REQUIREMENTS

110V Operation

The Model H4378 is wired for 110V and will draw 2.5 amps. The Model H4379 is wired for 110V and will draw 3.5 amps. If you operate this machine on any circuit that is already close to its capacity, it might blow a fuse or trip a circuit breaker. However, if an unusual load does not exist and a power failure still occurs, contact a qualified electrician or our service department.

A 10 amp dedicated circuit should be used with this grinder. Always check to see if your current wires are capable of handling a 10 amp load. If you are unsure, consult the advice of a qualified electrician.



Extension Cords

If you find it necessary to use an extension cord with the Model H4378/H4379, make sure the cord is rated Hard Service (grade S) or better. Refer to the chart in the standard safety instructions to determine the minimum gauge for the extension cord. The extension cord must also contain a ground wire and plug pin. Always repair or replace extension cords when they become worn or damaged.



Grounding

In the event of an electrical short, grounding reduces the risk of electric shock by providing electric current a path of least resistance. This tool is equipped with a power cord having an equipment-grounding conductor. **See Figure 1B.** The outlet must be properly installed and grounded in accordance with all local codes and ordinances.

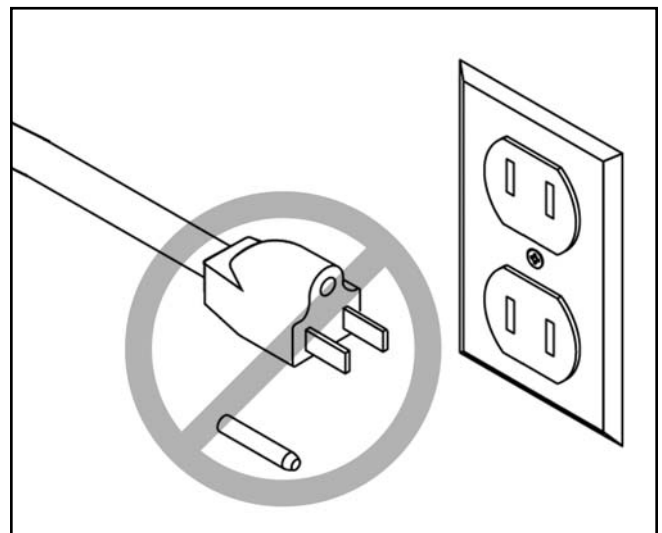
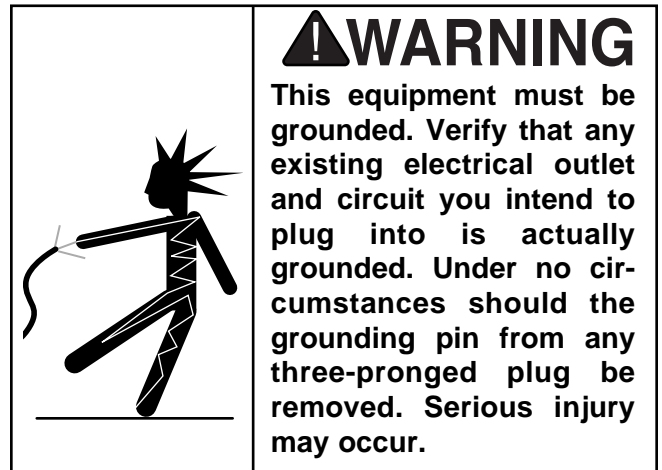

Figure 1A. Do not remove grounding pin.

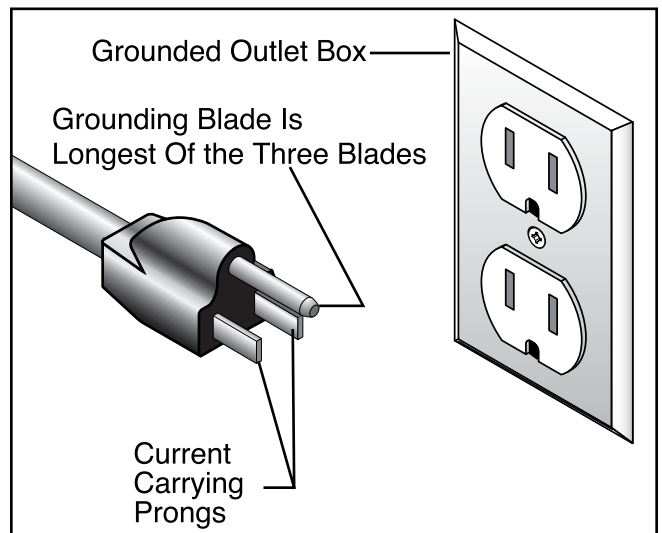

Figure 1B. Typical 110V plug and outlet.



SECTION 3: INTRODUCTION

Commentary

We are proud to offer the Grizzly Model H4378/H4379 Slimline Bench Grinder. The Model H4378/H4379 is part of a growing Grizzly family of fine woodworking machinery. When used according to the guidelines set forth in this manual, you can expect years of trouble-free, enjoyable operation and proof of Grizzly's commitment to customer satisfaction.

The Model H4378 offers a $\frac{1}{3}$ HP, 3450 RPM motor and a 6" grinding wheel. The Model H4379 offers a $\frac{1}{2}$ H.P., 3450 RPM motor and an 8" grinding wheel.

A number of grinding wheels for the Model H4378/H4379 are available through the Grizzly catalog.

We are also pleased to provide this manual with the Model H4378/H4379. It was written to guide you through assembly, review safety considerations, and cover general operating procedures. This manual represents our effort to produce the best documentation possible. If you have any comments regarding this manual, please write to us at the address below:

Grizzly Industrial, Inc.
c/o Technical Documentation
P.O. Box 2069
Bellingham, WA 98227-2069

Most importantly, we stand behind our machines. If you have any service questions or parts requests, please call or write us at the location listed below:

Grizzly Industrial, Inc.
1203 Lycoming Mall Circle
Muncy, PA 17756
Phone: (570) 546-9663
Fax: (800) 438-5901
E-Mail: techsupport@grizzly.com
Web Site: <http://www.grizzly.com>

The specifications, drawings, and photographs illustrated in this manual represent the Model H4378/H4379 as supplied when the manual was prepared. However, owing to Grizzly's policy of continuous improvement, changes may be made at any time with no obligation on the part of Grizzly. Whenever possible, though, we send manual updates to all owners of a particular tool or machine. Should you receive one, we urge you to insert the new information with the old and keep it for reference.

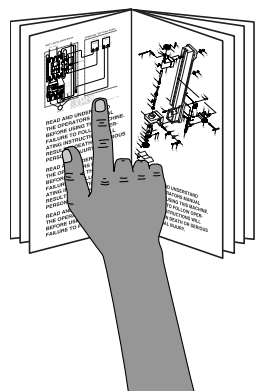
 An illustration of a hand with the index finger pointing to a specific page in a manual. The manual is open, showing a technical drawing on the left page and a photograph of a machine on the right page. The hand is rendered in a simple, shaded style.	<p>⚠ WARNING</p> <p>Read the manual before assembly and operation. Become familiar with the machine and its operation before beginning any work. Serious personal injury may result if safety or operational information is not understood or followed.</p>
---	---



SECTION 4: ASSEMBLY

Unpacking

The Model H4378/H4379 is shipped from the manufacturer in a carefully packed carton. If you discover the machine is damaged after you have signed for delivery, immediately call Customer Service for advice.

When you are completely satisfied with the condition of your shipment, you should inventory its parts.

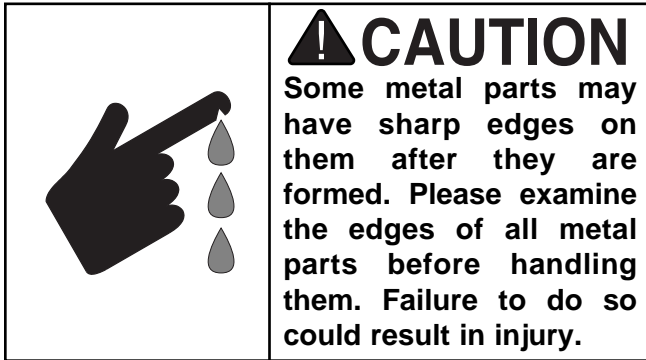

Piece Inventory

After all the parts have been removed from the carton, you should have:

- Grinder
- Bolts (4)
- Washers (6)
- Knobs (2)
- Adjustable Rests (2)
- Eye Shields (2)
- Spark Breakers (2)
- Cooling Tray

NOTICE

A full parts list and breakdown can be found toward the end of this manual. For easier assembly, or to identify specific parts, please refer to the detailed illustrations at the end of the manual.

NOTICE

When mounted, the cooling tray can be easily damaged if the grinder is tipped forward.



Mounting

The Model H4378/H4379 weighs 22/27 lbs. Make sure the workbench on which you plan to mount the grinder is sturdy enough to hold the weight of the machine and any downward pressure that may be applied during operation. The workbench should have a level surface and be heavy, or attached to the floor, so it will not move during operation. To mount the grinder:

- Pick a spot on the workbench that will allow enough room to move the size of an anticipated workpiece around the grinder. The operator (and possibly bystanders) should have enough room to stand out of the way in an emergency.
- Mount the grinder to the workbench with bolts that are long enough to exceed the thickness of your workbench and the grinder base. Secure each bolt with flat washers, a lock washer and a hex nut. *Because sizes vary for each individual situation, the hardware in this step is not included with the Model H4378/H4379.*
- Mount the grinder in an area with proper lighting and near electrical outlets. Lighting should be bright enough to eliminate shadow and prevent eye strain. Electrical circuits should be dedicated or large enough to handle amperage requirements. Keep power or extension cords clear of high-traffic areas. Observe local electrical codes for proper installation of new lighting, outlets, or circuits.

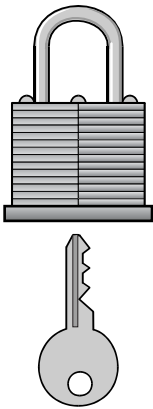
	<p>⚠ CAUTION</p> <p>Make your shop “child safe.” Ensure that your workplace is inaccessible to children by closing and locking all entrances when you are away. Never allow visitors in your shop when assembling, adjusting, or operating equipment.</p>
---	---

Tool Rests

The tool rest provides a surface that can be used to support the workpiece during grinding. Certain types of grinding may require jigs or accessories to assure the proper angle of the workpiece against the wheel.

The tool rest attaches to the inward side of the wheel guard; it should be positioned as close to the grinding wheel as possible. Insert the ½" x ¼" hex bolt with a flat washer and a lock washer through the rest support, and thread it into the tapped hole. Repeat this installation for the opposite side wheel. The tool rest can be adjusted by loosening these bolts and moving the bracket. Always retighten before using the machine.



Eye Shields

OSHA requires that the eye shield be positioned between the grinding wheel and the operator's face during grinding. This lessens the possibility of sparks or metal bits flying directly at the operator.

Attach each support bracket to the top end of the wheel rim guards with the knob bolts. Note that the brackets are slotted to allow up and down adjustments.

Snap the eye shields into the grooves on the support brackets. The shields should be able to swivel up and down.



SECTION 5: OPERATIONS

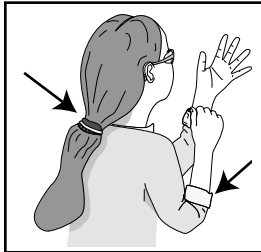

⚠️ WARNING
Keep loose clothing rolled up and out of the way of machinery and keep hair pulled back.

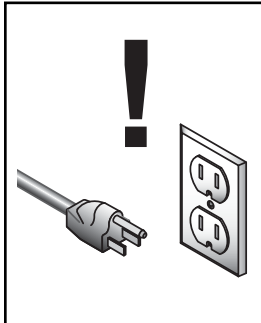

⚠️ WARNING
Disconnect power to the machine when performing any maintenance, assembly or adjustments. Failure to do this may result in serious personal injury.

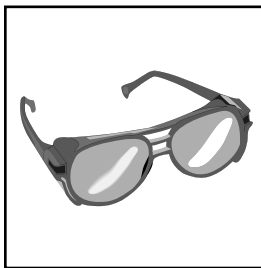

⚠️ WARNING
Wear safety glasses during the entire operation process. Failure to comply may result in serious personal injury.

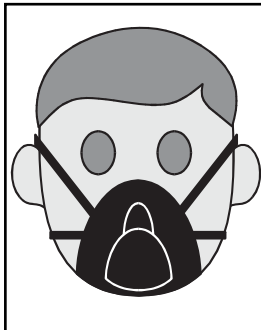

⚠️ CAUTION
Using this machine produces dust which may cause allergic reactions and respiratory problems. Use an approved dust mask to protect yourself from these hazards!

NOTICE

The following section was designed to give instructions on the basic operations of this grinder. However, it is in no way comprehensive of every grinder application. There are many different grinding wheels and attachments available for grinders. **WE STRONGLY RECOMMEND** that you read books, trade magazines, or get formal training to maximize the potential of your machine.

Test Run

Once mounting is complete and adjustments are done to your satisfaction, you are ready to test the machine.

Plug the grinder into the power source. Stand away from the line of rotation of the wheel and turn the grinder **ON**. The grinder should run smoothly with little or no vibration or rubbing noises. Strange or unnatural noises should be investigated and corrected before operating the machine further. If the grinder seems okay, stay out of the line of rotation and let it run for 1-2 minutes to make sure the wheel is structurally sound.

If you cannot easily locate the source of an unusual noise or vibration, feel free to contact our service department for help.



Safe Grinding

The grinder is a safe tool when used properly. In addition to the safety instructions in this manual, the most important safety consideration is to use common sense at all times. What may be okay in one situation, may not be safe in another.

Here are some tips to keep in mind while grinding:

- Make sure all guards are in place.
- Remember that grinding often produces sparks. DO NOT allow anyone to stand in the path of the sparks. DO NOT grind near flammable liquids or gases.
- Maintain proper care of your wheels. Read the “Wheel Care” instructions for ideas on how to go about doing this.
- Wear the proper protective clothing. Remember that particles flying off of a grinding wheel will be traveling very fast—prepare for this. Wear safety glasses, a dust mask, earplugs, a leather apron, arm guards, a hardhat and heavy leather boots.
- Grasp the workpiece tight and properly support it on the tool rest during operation. DO NOT lean into the workpiece in a manner that may cause your hands to move into the spinning wheel if the workpiece slips off.
- Concentrate on the task at hand. STOP grinding if other people are distracting you. STOP grinding if your mind is on something else.
- DO NOT grind on the side of the wheel. Although side grinding is permissible for some wheel types, the Model H4378/H4379 is not designed for side grinding.



Wheel Care

Your safety when grinding depends, on a large part, on the condition of the wheel during grinding. A wheel in poor condition presents the possibility of breaking apart during rotation and injuring the operator and possibly causing property damage.

Here are some tips to help you avoid breaking the wheel:

- Always transport, store and handle wheels with care. Wheels may be damaged if they are dropped or if heavy objects are stacked on them.
- Select the right grinding wheel for the job. Do not grind material that is not designed for the wheel.
- Select the right machine for the wheel. A machine that rotates at a higher RPM than the wheel is rated for may cause the wheel to fly apart.
- Mount the wheels properly. (See the “Wheel Mounting” instructions on **page 13** for guidance.) Never use a wheel with the wrong arbor size for the grinder.
- Do not abuse the wheel by jamming the work into the grinding wheel with excessive force.
- Learn how to use the grinder and the grinding wheels properly. Ask a trusted person with experience or consult with your local library to learn more.
- If using coolant, always spin it out of the wheel before turning off the power.
- Grinding on side of the wheel may cause wheel damage.



Wheel Selection

The Model H4378 only accepts Type-1 wheels with a 1/2" bore. The Model H4379 only accepts Type-1 wheels with a 5/8" bore.

Aluminum oxide and silicon carbide wheels are marked in a somewhat uniform manner by all the major manufacturers. Understanding these markings will help you understand the capabilities of various wheels. Always refer to the manufacturer's grinding recommendations when selecting a wheel for your project.

The basic format for wheel numbering is:

Prefix	Abrasive Type	Grit Size	Grade	Bond Type
1	A	60	L	V

The *Prefix* is the manufacturer's designation for a particular type.

The most common *Abrasive Types* used are A for Aluminum Oxide and C for Silicon Carbide, and occasionally SG for Seeded Gel.

The *Grit Size* is a number that refers to the size of the abrasive grain in the wheel. The lower the number, the coarser the wheel. 10 is a very coarse wheel for roughing and 220 is usually the upper range for fine finish work.

Grade is an indication of the hardness of the wheel—"A" being the softest and "Z" being the hardest.

Bond Type refers to the type of bonding material used to hold the abrasive material. Most general purpose wheels will have a "V" indicating Vitrified Clay is used. Vitrified Clay provides high strength and good porosity. The other common bond type is "B" for resin where synthetic resins are used. These are used to grind cemented carbide and ceramic materials.

There may be other numbers inserted that have meaning for a particular type of wheel. Refer to the manufacturer's technical data for a complete explanation.



Wheel Inspection

Before mounting a new grinding wheel, it must be inspected. Do not assume that a wheel is in sound condition just because it is new—often, damage can occur in shipping, with age, or with exposure to moisture.

First, the wheel should be given a **Visual Inspection**. Look for any cracks, chips, nicks or dents in the surface of the wheel. If you see any of these, **DO NOT** use the wheel.

Second, the wheel should be given a **Ring Test**. This test will give you an indication of any internal damage that may not be obvious during a visual inspection.

To perform a Ring Test:

1. Make sure the wheel that you test is clean and dry; otherwise, you may get false results.
2. If size permits, balance the wheel with your finger in the hole. If this is not possible, hang the wheel in the air with a piece of cord or string looped through the hole in the center.
3. At the spots shown in **Figure 2**, gently tap the wheel with a light non-metallic device such as the handle of a screwdriver or a wooden mallet.

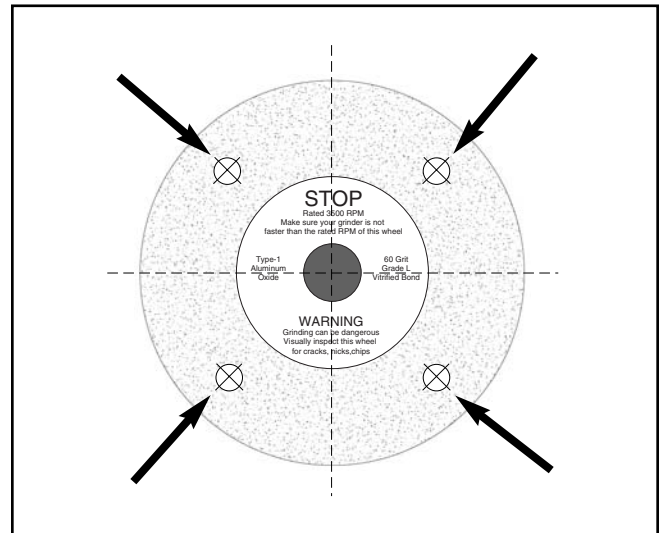

Figure 2. Ring test tapping locations.

4. An undamaged wheel will emit a clear metallic ring or “ping” sound in each of these spots. A damaged wheel will respond with a dull thud that has no clear tone.
5. If you determine from the ring test that the wheel is damaged, **DO NOT** use it!



Wheel Mounting

The wheel guard assembly must be removed in order to mount or dismount a grinding wheel. To do this:

1. **Disconnect the grinder from the power supply!**
2. Remove the 3 Phillips head screws and nuts that go through the outer guard. Take off the outer guard and the rim guard.
3. Use a wrench on the nut that holds the wheel on the arbor. Hold the wheel from turning with your other hand. Note that the wheel on the left-hand side of the machine is a left-handed thread, so loosening it will require turning it clockwise.
4. Remove the outer wheel flange and the paper disc. Pull the wheel free from the arbor. There will also be a paper disc and a wheel flange on the back side of the wheel.
5. Mount the new wheel in the reverse order or as shown in **Figure 3**. Always make certain there is a paper or fiber disc between the wheel flanges and the wheel itself. Tighten the nut snugly but **DO NOT** over-tighten. Over-tightening can crack the wheel.
6. Re-install the guards and shields.
7. Run a new wheel for at least 1-2 minutes while standing clear of the line of rotation. If a wheel does have defects it will generally fail as soon as it gets up to full speed.

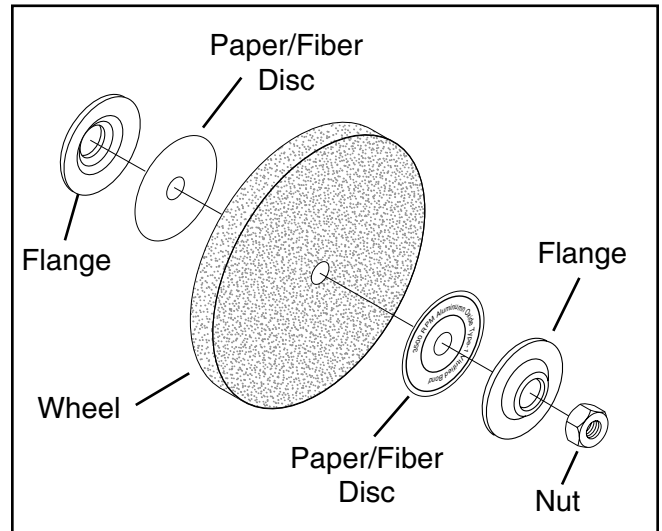

Figure 3. Wheel mounting order.

CAUTION

NEVER assemble a grinding wheel on the arbor without paper or fiber discs between the wheel and the flange. Omitting the discs can put undue stress on the wheel, causing it to crack and possibly fall apart.

CAUTION

ALWAYS visually inspect and perform a “ring test” on a wheel before assembly. **DO NOT** use damaged wheels!



SECTION 6: MAINTENANCE

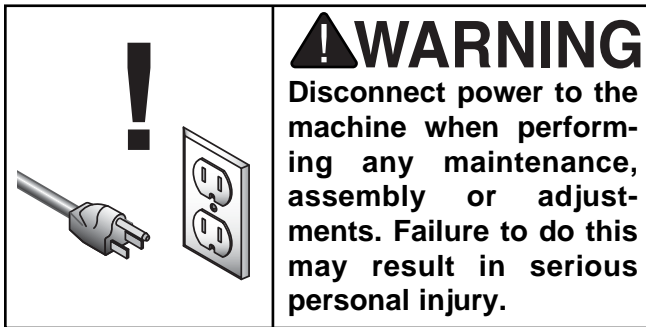

General

Always be aware of the condition of your grinder. Routinely check the condition of the following items and repair or replace as necessary:

- Loose mounting bolts
- Worn switch
- Worn or damaged cord
- Worn or damaged support bearings or guide bearings
- Damaged grinding wheel
- Any other condition that could hamper the safe operation of this machine.



NOTICE

If the grinder is unmounted from the workbench for maintenance, the cooling tray can be easily damaged if the grinder is tipped forward.

Lubrication

Sealed and pre-lubricated ball bearings require no lubrication for the life of the bearings. All bearings are standard sizes, and replacements can be purchased from our parts department or a bearing supply store.



Grinding Wheels

The grinding wheel should be inspected before every use. Use the “ring test” method from **page 12** “Wheel Mounting” instructions to verify the structural integrity. If using coolant during grinding, always run the wheel for 5-10 minutes at the end of the operation to remove any coolant from the wheel. Take care in storing grinding wheels to keep them free from potential damage by being dropped or having other items dropped on them.

Replace the wheel when the wheel diameter is reduced to 4" on the Model H4378 and 6" on the Model H4379. Operating at anything less than this diameter does not allow the proper alignment of the tool rest and the eye shield.

Depending on the type of grinding you do, the grinding wheel may require periodic dressing. There are several different types of wheel dressing devices available on the market. Use a suitable diamond or silicon carbide stick type dresser. Sweep it smoothly and evenly several times across the face of the wheel. Dressing restores the abrasive quality of the wheel surface, plus it will bring the wheel edge back to a square form. Refer to the instructions that accompany your dressing accessory for complete details on wheel dressing.



Maintenance Notes

Date	Approximate Hours Of Use	Maintenance Performed



SECTION 8: CLOSURE

The following pages contain general machine data, parts diagrams/lists, a troubleshooting guide and Warranty/Return information for your Model H4378/H4379.

If you need parts or help in assembling your machine, or if you need operational information, we encourage you to call our Service Department. Our trained service technicians will be glad to help you.

If you have comments dealing specifically with this manual, please write to our Bellingham, Washington location using the address in *Section 3: Introduction*.

We have included some important safety measures that are essential to the operation of this machine. While most safety measures are generally universal, Grizzly reminds you that each workshop is different and safety rules should be considered as they apply to your specific situation.

We recommend you keep a copy of our current catalog for complete information regarding Grizzly's warranty and return policy. If you need additional technical information relating to this machine, or if you need general assistance or replacement parts, please contact the Service Department listed in *Section 3: Introduction*.

Additional information sources are necessary to realize the full potential of this machine. Trade journals, woodworking magazines, and your local library are good places to start.

WARNING

Operating this equipment creates the potential for flying debris to cause eye injury. Always wear safety glasses or goggles when operating equipment. Everyday glasses or reading glasses only have impact resistant lenses, they are not safety glasses. Be certain the safety glasses you wear meet the appropriate standards of the American National Standards Institute (ANSI).



WARNING

The Model H4378/H4379 was specifically designed for grinding. DO NOT MODIFY AND/OR USE THIS MACHINE FOR ANY OTHER PURPOSE. Modifications or improper use of this tool will void the warranty. If you are confused about any aspect of this machine, DO NOT use it until all your questions have been answered or serious personal injury may occur.

WARNING

Like all power tools, there is danger associated with the Model H4378/H4379. Accidents are frequently caused by lack of familiarity or failure to pay attention. Use this tool with respect and caution to lessen the possibility of operator injury. If normal safety precautions are overlooked or ignored, serious personal injury may occur.



TROUBLESHOOTING

This section covers the most common problems encountered in grinding and what to do about them. Do not make any adjustments until grinder is unplugged and moving parts have come to a complete stop.

SYMPTOM	POSSIBLE CAUSE	CORRECTIVE ACTION
Motor will not start.	<ol style="list-style-type: none"> 1. Low voltage. 2. Open circuit in motor or loose connections. 	<ol style="list-style-type: none"> 1. Check power line for proper voltage. 2. Inspect all lead connections on motor for loose or open connections.
Motor will not start; fuses or circuit breakers blow.	<ol style="list-style-type: none"> 1. Short circuit in line cord or plug. 2. Short circuit in motor or loose connections. 3. Incorrect fuses or circuit breakers in power line. 	<ol style="list-style-type: none"> 1. Inspect cord or plug for damaged insulation and shorted wires. 2. Inspect all connections on motor for loose or shorted terminals or worn insulation. 3. Install correct fuses or circuit breakers.
Motor overheats.	<ol style="list-style-type: none"> 1. Motor overloaded. 	<ol style="list-style-type: none"> 1. Reduce load on motor.
Motor stalls (resulting in blown fuses or tripped circuit).	<ol style="list-style-type: none"> 1. Short circuit in motor or loose connections. 2. Low voltage. 3. Incorrect fuses or circuit breakers in power line. 4. Motor overloaded. 	<ol style="list-style-type: none"> 1. Inspect connections on motor for loose or shorted terminals or worn insulation. 2. Correct the low voltage conditions. 3. Install correct fuses or circuit breakers. 4. Reduce load on motor.
Machine slows when operating.	<ol style="list-style-type: none"> 1. Depth of cut too great. 	<ol style="list-style-type: none"> 1. Slow down the rate of movement of the workpiece into wheel.
Wavy condition on surface of workpiece.	<ol style="list-style-type: none"> 1. Machine vibrating. 2. Workpiece not being held firmly. 3. Wheel face uneven. 4. Wheel is too hard. 	<ol style="list-style-type: none"> 1. Make sure machine is securely mounted on a solid surface. 2. Use a holding device to firmly retain the workpiece. 3. Dress the grinding wheel. 4. Use softer wheel, or reduce the feed rate.
Lines on surface of workpiece.	<ol style="list-style-type: none"> 1. Impurity on wheel surface. 2. Workpiece not being held tightly. 	<ol style="list-style-type: none"> 1. Dress the grinding wheel. 2. Use a holding device to firmly retain the workpiece.
Burning spots or cracks in the workpiece.	<ol style="list-style-type: none"> 1. Improper type of grinding wheel. 2. Improper feed rate. 3. Coolant required. 	<ol style="list-style-type: none"> 1. Try a wheel which is softer style or a coarser grit. 2. Slow down the rate of movement of the workpiece into wheel. 3. Add optional coolant system or introduce coolant by hand.
Wheel dulls quickly, grit falls off.	<ol style="list-style-type: none"> 1. Depth of cut too great. 2. Wheel is too soft. 3. Wheel diameter too small. 4. Bad wheel dress. 5. Defective wheel bonding. 	<ol style="list-style-type: none"> 1. Slow down the rate of movement of the workpiece into wheel. 2. Wheel too soft for the material being ground, select harder bond. 3. Replace the wheel. 4. Dress the wheel. 5. Consult manufacturer of grinding wheel.
Wheel clogs and workpiece shows burn marks.	<ol style="list-style-type: none"> 1. Wheel is too hard. 2. Feed rate too slow. 3. Bad wheel dress. 4. Coolant required. 	<ol style="list-style-type: none"> 1. Wheel too hard for the material being ground, select softer bond. 2. Increase the rate of movement of the workpiece into wheel. 3. Dress the wheel. 4. Add optional coolant system or introduce coolant by hand.

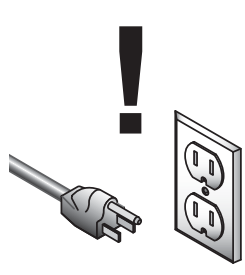

⚠ WARNING

Disconnect power to the machine when performing any maintenance, assembly or adjustments. Failure to do this may result in serious personal injury.



MACHINE DATA SHEET

Customer Service #: (570) 546-9663 • To Order Call: (800) 523-4777 • Fax #: (800) 438-5901

MODEL H4378 SLIMLINE BENCH GRINDER

Design Type..... Bench Model

Overall Dimensions:

Height10"
 Width.....18⁵/₁₆"
 Depth10"
 Shipping Weight25 lbs.
 Net Weight.....22 lbs.
 Box Size17¹/₂" L x 9¹/₄" W x 10¹/₂" H
 Footprint.....8" x 7⁵/₁₆"
 Arbor¹/₂"
 Wheel Size6" x ³/₄"

Motor:

TypeTEFC Capacitor-Start Induction
 Horsepower¹/₃ HP
 Phase / VoltageSingle-Phase / 110V
 Amps (No Load)2.5
 Cycle / RPM60 Hertz / 3450 RPM
 BearingsShielded & Permanently Lubricated

Features:

.....Wheel Flanges
Tool Rests
Rocker-Type Switch
Extended Wheel-to-Motor Clearance
Convenient Water Tray
Included 36 Grit Aluminum Oxide Grinding Wheel
Included 60 Grit Aluminum Oxide Grinding Wheel

Specifications, while deemed accurate, are not guaranteed.



MACHINE DATA SHEET

Customer Service #: (570) 546-9663 • To Order Call: (800) 523-4777 • Fax #: (800) 438-5901

MODEL H4379 SLIMLINE BENCH GRINDER

Design Type..... Bench Model

Overall Dimensions:

Height.....10 $\frac{1}{2}$ "
 Width.....18 $\frac{7}{16}$ "
 Depth.....10 $\frac{13}{16}$ "
 Shipping Weight.....30 lbs.
 Net Weight.....27 lbs.
 Box Size.....18" L x 11" W x 11 $\frac{1}{4}$ " H
 Footprint.....8" x 7 $\frac{5}{16}$ "
 Arbor..... $\frac{5}{8}$ "
 Wheel Size.....8" x $\frac{3}{4}$ "

Motor:

Type.....TEFC Capacitor-Start Induction
 Horsepower..... $\frac{1}{2}$ " HP
 Phase / Voltage.....Single-Phase / 110V
 Amps (No Load).....3.5
 Cycle / RPM.....60 Hertz / 3450 RPM
 Bearings.....Shielded & Permanently Lubricated

Features:

.....Wheel Flanges
Tool Rests
Rocker-Type Switch
Extended Wheel-to-Motor Clearance
Convenient Water Tray
Included 36 Grit Aluminum Oxide Grinding Wheel
Included 60 Grit Aluminum Oxide Grinding Wheel

Specifications, while deemed accurate, are not guaranteed.

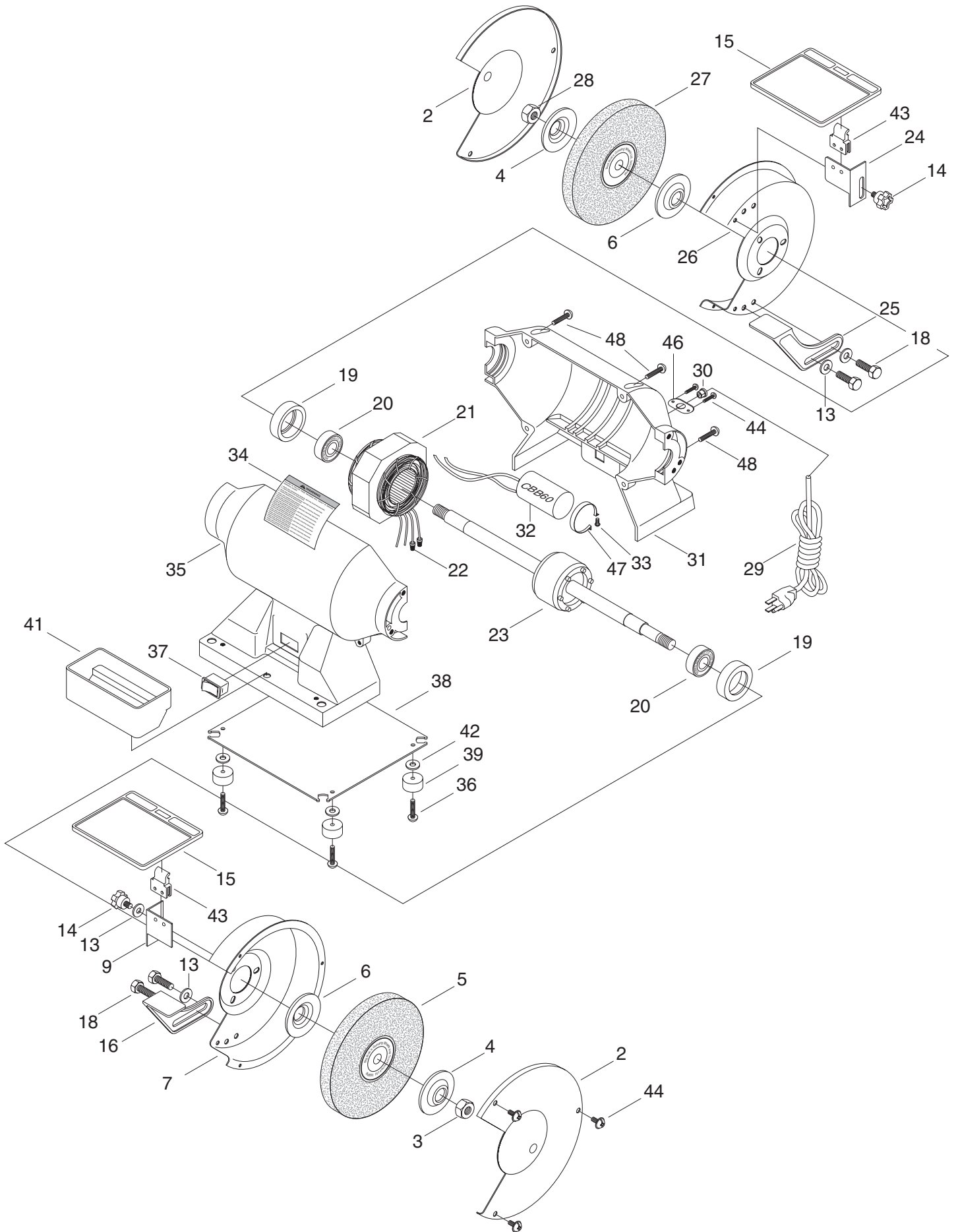

MODEL H4378 PARTS

Ref#	Part#	Description
02	PH4378002	COVER
03	PN06	HEX NUT 1/2"
04	PH4378004	FLANGE
05	PH4378005	GRINDER WHEEL
06	PH4378006	FLANGE
07	PH4378007	WHEEL GUARD
09	PH4378009	SPARK BREAKER
13	PW06	FLAT WASHER 5/16"
14	PH4378014	KNOB SCREW 1/4"-20 X 3/8"
15	PH4378015	EYESHIELD
16	PH4378016	ADJUSTABLE REST
18	PB15	HEX BOLT 5/16"-18 X 3/8"
19	PH4378019	BUSHING
20	P6202	BALL BEARING 6202-2RS
21	PH4378021	MOTOR STATOR
22	PH4378022	WIRE NUT
23	PH4378023	MOTOR SHAFT
24	PH4378024	SPARK BREAKER
25	PH4378025	ADJUSTABLE REST
26	PH4378026	WHEEL GUARD

Ref#	Part#	Description
27	PH4378027	GRINDER WHEEL
28	PN26	LEFT HAND HEX NUT 1/2"
29	PH4378029	WIRE
30	PH4378030	STRAIN RELIEF
31	PH4378031	BACK BODY
32	PH4378032	CAPACITOR CBB60
33	PS01	PHLP HD SCR 10-24 X 1/2"
34	PH4378034	MACHINE ID LABEL
35	PH4378035	FRONT BODY
36	PS22	PHLP HD SCR 10-24 X 5/8"
37	PH4378037	SWITCH
38	PH4378038	BASE PLATE
39	PH4378039	PAD
41	PH4378041	COOLING TRAY
42	PW03	FLAT WASHER #10
43	PH4378043	EYESHIELD CLIP
44	PS06	PHLP HD SCR 10-24 X 3/8"
46	PH4378046	STRAIN RELIEF PLATE
47	PH4378047	CAPACITOR BRACKET
48	PS01	PHLP HD SCR 10-24 X 1"

MODEL H4379 PARTS

Ref#	Part#	Description
02	PH4379002	COVER
03	PN04	HEX NUT 5/8"
04	PH4379004	FLANGE
05	PH4379005	GRINDER WHEEL
06	PH4379006	FLANGE
07	PH4379007	WHEEL GUARD
09	PH4378009	SPARK BREAKER
13	PW06	FLAT WASHER 5/16"
14	PH4378014	KNOB SCREW 1/4"-20 X 3/8"
15	PH4378015	EYESHIELD
16	PH4378016	ADJUSTABLE REST
18	PB15	HEX BOLT 5/16"-18 X 3/8"
19	PH4379019	BUSHING
20	P6203	BALL BEARING 6203-2RS
21	PH4379021	MOTOR STATOR
22	PH4378022	WIRE NUT
23	PH4379023	MOTOR SHAFT
24	PH4378024	SPARK BREAKER
25	PH4378025	ADJUSTABLE REST
26	PH4379026	WHEEL GUARD

Ref#	Part#	Description
27	PH4379027	GRINDER WHEEL
28	PN27	LEFT HAND HEX NUT 5/8"
29	PH4378029	WIRE
30	PH4378030	STRAIN RELIEF
31	PH4378031	BACK BODY
32	PH4378032	CAPACITOR CBB60
33	PS01	PHLP HD SCR 10-24 X 1/2"
34	PH4379034	MACHINE ID LABEL
35	PH4378035	FRONT BODY
36	PS22	PHLP HD SCR 10-24 X 5/8"
37	PH4378037	SWITCH
38	PH4378038	BASE PLATE
39	PH4378039	PAD
41	PH4378041	COOLING TRAY
42	PW03	FLAT WASHER #10
43	PH4378043	EYESHIELD CLIP
44	PS06	PHLP HD SCR 10-24 X 3/8"
46	PH4378046	STRAIN RELIEF PLATE
47	PH4378047	CAPACITOR BRACKET
48	PS01	PHLP HD SCR 10-24 X 1"

WARRANTY AND RETURNS

Grizzly Industrial, Inc. warrants every product it sells for a period of **1 year** to the original purchaser from the date of purchase. This warranty does not apply to defects due directly or indirectly to misuse, abuse, negligence, accidents, repairs or alterations or lack of maintenance. This is Grizzly's sole written warranty and any and all warranties that may be implied by law, including any merchantability or fitness, for any particular purpose, are hereby limited to the duration of this written warranty. We do not warrant or represent that the merchandise complies with the provisions of any law or acts unless the manufacturer so warrants. In no event shall Grizzly's liability under this warranty exceed the purchase price paid for the product and any legal actions brought against Grizzly shall be tried in the State of Washington, County of Whatcom.

We shall in no event be liable for death, injuries to persons or property or for incidental, contingent, special, or consequential damages arising from the use of our products.

To take advantage of this warranty, contact us by mail or phone and give us all the details. We will then issue you a "Return Number," which must be clearly posted on the outside as well as the inside of the carton. We will not accept any item back without this number. Proof of purchase must accompany the merchandise.

The manufacturers reserve the right to change specifications at any time because they constantly strive to achieve better quality equipment. We make every effort to ensure that our products meet high quality and durability standards and we hope you never need to use this warranty.

Please feel free to write or call us if you have any questions about the machine or the manual.

Thank you again for your business and continued support. We hope to serve you again soon.

WARRANTY CARD

Name _____
Street _____
City _____ State _____ Zip _____
Phone Number _____ E-Mail _____ FAX _____
MODEL # H4378/H4379 Slimline Bench Grinder Serial# _____ Order# _____

The following information is given on a voluntary basis. It will be used for marketing purposes to help us develop better products and services. Of course, all information is strictly confidential.

- How did you learn about us?
 Advertisement Friend
 Catalog Card Deck
 World Wide Web
 Other _____
- Which of the following magazines do you subscribe to.
 American Woodworker Practical Homeowner
 Cabinetmaker Shop Notes
 Family Handyman Today's Homeowner
 Fine Homebuilding WOOD
 Fine Woodworking Wooden Boat
 Home Handyman Woodshop News
 Journal of Light Construction Woodsmith
 Old House Journal Woodwork
 Popular Mechanics Woodworker
 Popular Science Woodworker's Journal
 Popular Woodworking Workbench
 Other _____
- Which of the following woodworking/remodeling shows do you watch?
 Backyard America The New Yankee Workshop
 Home Time This Old House
 The American Woodworker Woodwright's Shop
 Other _____
- What is your annual household income?
 \$20,000-\$29,999 \$60,000-\$69,999
 \$30,000-\$39,999 \$70,000-\$79,999
 \$40,000-\$49,999 \$80,000-\$89,999
 \$50,000-\$59,999 \$90,000 +
- What is your age group?
 20-29 50-59
 30-39 60-69
 40-49 70 +
- How long have you been a woodworker?
 0 - 2 Years 8 - 20 Years
 2 - 8 Years 20+ Years
- How would you rank your woodworking skills?
 Simple Advanced
 Intermediate Master Craftsman
- What stationary woodworking tools do you own? Check all that apply.
 Air Compressor Panel Saw
 Band Saw Planer
 Drill Press Power Feeder
 Drum Sander Radial Arm Saw
 Dust Collector Shaper
 Horizontal Boring Machine Spindle Sander
 Jointer Table Saw
 Lathe Vacuum Veneer Press
 Mortiser Wide Belt Sander
 Other _____
- How many of your woodworking machines are Grizzly? _____
- Which benchtop tools do you own? Check all that apply.
 1" x 42" Belt Sander 6" - 8" Grinder
 5" - 8" Drill Press Mini Lathe
 8" Table Saw 10" - 12" Thickness Planer
 8" - 10" Bandsaw Scroll Saw
 Disc/Belt Sander Spindle/Belt Sander
 Mini Jointer
 Other _____
- How many of the machines checked above are Grizzly? _____
- Which portable/hand held power tools do you own? Check all that apply.
 Belt Sander Orbital Sander
 Biscuit Joiner Palm Sander
 Circular Saw Portable Planer
 Detail Sander Saber Saw
 Drill/Driver Reciprocating Saw
 Miter Saw Router
 Other _____
- What machines/supplies would you like Grizzly Industrial to carry?

- What new accessories would you like Grizzly Industrial to carry?

- What other companies do you purchase your tools and supplies from?

- Do you think your purchase represents good value?
 Yes No
- Would you recommend Grizzly Industrial to a friend?
 Yes No
- Would you allow us to use your name as a reference for Grizzly customers in your area? **Note: We never use names more than three times.**
 Yes No
- Comments: _____

FOLD ALONG DOTTED LINE



Place
Stamp
Here



GRIZZLY INDUSTRIAL, INC.
P.O. BOX 2069
BELLINGHAM, WA 98227-2069



FOLD ALONG DOTTED LINE

Send a Grizzly Catalog to a friend:

Name _____
Street _____
City _____ State _____ Zip _____

TAPE ALONG EDGES--PLEASE DO NOT STAPLE

