

Advanced Car Kit CK-7W User's Guide Installation Guide

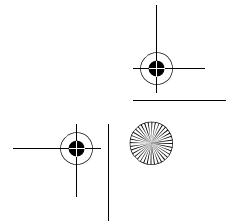

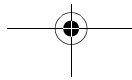
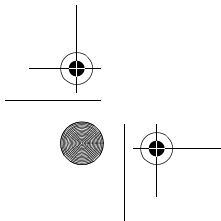
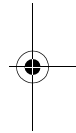
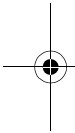

DECLARATION OF CONFORMITY

We, NOKIA CORPORATION, declare under our sole responsibility that the Advanced Car Kit CK-7W is in conformity with the provisions of the following Council Directive: 1999/5/EC. A copy of the Declaration of Conformity can be found at: http://www.nokia.com/phones/declaration_of_conformity/.

CE 168

Copyright © 2004 Nokia. All rights reserved.

Reproduction, transfer, distribution or storage of part or all of the contents of this document in any form without the prior written permission of Nokia is prohibited.

Nokia and Nokia Connecting People are trademarks or registered trademarks of Nokia Corporation. Other products and company names mentioned herein may be trademarks or tradenames of their respective owners.

Bluetooth is a registered trademark of Bluetooth SIG, Inc.

Nokia operates a policy of ongoing development. Nokia reserves the right to make changes and improvements to any of the products described in this document without prior notice.

UNDER NO CIRCUMSTANCES SHALL NOKIA BE RESPONSIBLE FOR ANY LOSS OF DATA OR INCOME OR ANY SPECIAL, INCIDENTAL, CONSEQUENTIAL OR INDIRECT DAMAGES HOWSOEVER CAUSED.

The contents of this document are provided "as is". Except as required by applicable law, no warranties of any kind, either express or implied, including, but not limited to, the implied warranties of merchantability and fitness for a particular purpose, are made in relation to the accuracy, reliability or contents of this document. Nokia reserves the right to revise this document or withdraw it at any time without prior notice.

The availability of particular products and services may vary by region. Please check with the Nokia dealer nearest to you.

EXPORT CONTROLS

This product contains commodities, technology or software exported from the United States in accordance with the Export Administration regulations. Diversion contrary to U.S. or Canadian law is prohibited.

FCC/INDUSTRY CANADA NOTICE

This device complies with Part 15 of the FCC Rules. Operation is subject to the following two conditions: (1) this device may not cause harmful interference, and (2) this device must accept any interference received, including interference that may cause undesired operation.

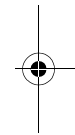
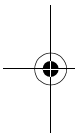



Contents

- For your safety 1**
- Introduction 2**
 - Your Nokia Advanced Car Kit CK-7W. 2
 - Bluetooth wireless technology 3
 - Bluetooth passcode 3
- 1 Getting started 4**
 - Overview. 4
 - Use of enhancements 5
- 2 Installation 6**
 - Safety information. 6
 - Configuration 8
 - Installing the Advanced Car Kit CK-7W. 10
 - Function test 13
- 3 Using the Advanced Car Kit. 14**
 - Connecting a mobile phone using Bluetooth
wireless technology. 14
 - Connecting a mobile phone over the data cable. 15
- 4 Operation 16**
 - Remote control button 16
 - Switching the Advanced Car Kit CK-7W on/off 17
 - Operating the Advanced Car Kit CK-7W 17
- Care and maintenance. 20**
- Nokia One-Year Limited Warranty (U.S.). 21**
- Nokia One-Year Limited Warranty (Canada) 21**

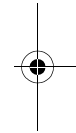
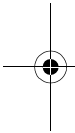

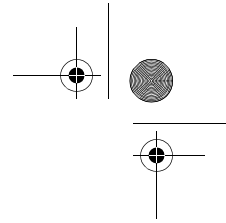
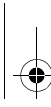
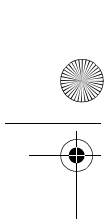

NOTES

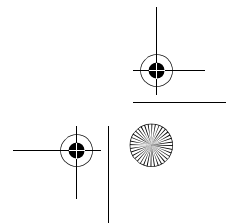
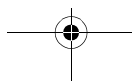
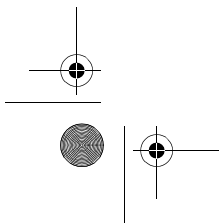
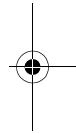
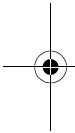



For your safety

Read these simple guidelines. Breaking the rules may be dangerous or illegal. Further detailed information is given in this user's guide.

Keep all miniature SIM cards and accessories out of the reach of small children.



ROAD SAFETY COMES FIRST

Remember that the safety of operating a motor vehicle in traffic requires the full attention of all motorists. Only use your Advanced Car Kit CK-7W if traffic conditions permit safe use and check if local laws/regulations restrict the use of mobile phones while driving.



INTERFERENCE

All wireless phones may get interference, which could affect performance.



QUALIFIED INSTALLATION AND SERVICE

Only a qualified professional may install or repair phone equipment.



CONNECTING TO OTHER DEVICES

When connecting to any other device using Bluetooth wireless technology, read the relevant user's guide for detailed safety instructions. Do not connect incompatible products.



FUSE REPLACEMENT

Replace a blown fuse with a fuse of the same type and size. Never use a fuse with a higher rating!

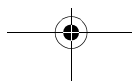
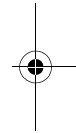
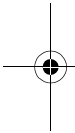



Introduction

- **YOUR NOKIA ADVANCED CAR KIT CK-7W**

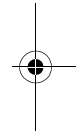
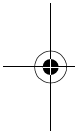
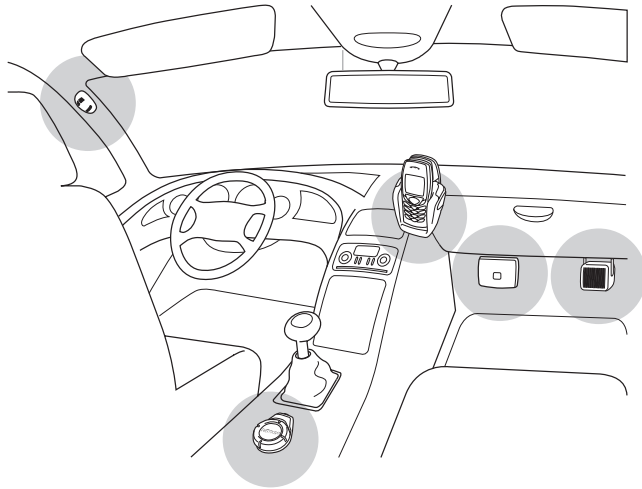

Advanced Car Kit CK-7W equipment installation in the console.

The Nokia Advanced Car Kit CK-7W was developed for installation in motor vehicles to enable handsfree operation of mobile phones and use of individual phone features.

A special emphasis was placed on quick and easy installation. A mobile phone can be connected to the Advanced Car Kit in one of two ways: using an optional phone holder with a cable or over a Bluetooth wireless connection.

In some countries, use of the Advanced Car Kit may be restricted by law. Please observe the applicable rules and regulations.

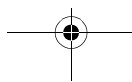



• **BLUETOOTH WIRELESS TECHNOLOGY**

Bluetooth wireless technology is an international standard for short-range wireless communication. It allows you to establish a wireless connection within a range of 32.8 feet between your Advanced Car Kit and a compatible device.

The Advanced Car Kit is intended for use with any mobile phone that supports the Bluetooth Handsfree Profile (Bluetooth specification 1.1).

The wireless connection between the compatible devices established using Bluetooth technology is free of charge for the user. In some countries, there may be restrictions on using Bluetooth devices. Check with your local authorities.

• **BLUETOOTH PASSCODE**

The first time you wish to establish a wireless connection to a compatible device using Bluetooth technology, you will need to input a passcode to pair the devices.

The passcode is a four-digit numeric code that corresponds to the last four digits in the serial number supplied with your Advanced Car Kit.

You will find the serial number on the type label attached to the handsfree unit and on the sticker that comes with this user's guide.

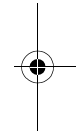
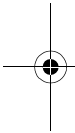

1 Getting started

- OVERVIEW

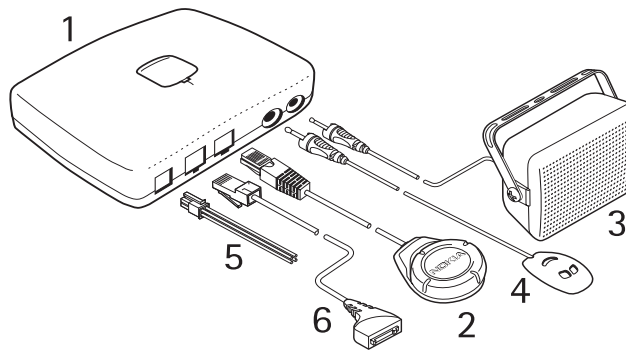

The Advanced Car Kit CK-7W includes the components shown above.

- 1 Handsfree unit HF-5 with mounting plate MK-2
- 2 Remote control button CU-7
- 3 Loudspeaker HFS-12
- 4 Microphone HFM-8
- 5 Cable set PCU-4
- 6 Data cable CA-27



Getting started



• USE OF ENHANCEMENTS

Depending on the setup, a variety of optional enhancements are available to extend your Advanced Car Kit. Before any installation work is started, ask for professional advice on the enhancements that would best suit your needs. Use only approved enhancements. Ensure that only compatible products are connected to your Advanced Car Kit.

Phone holder

A phone holder may be purchased with your car kit or separately as an enhancement.

You will need a phone holder designed for a compatible mobile phone if the mobile phone is to be connected directly to the handsfree unit using the data cable.

Antenna coupler

An antenna coupler may be purchased with your car kit or separately as an enhancement.

An antenna coupler is required to connect an external antenna. A range of antenna couplers are commercially available for the mobile phones and phone holders on the market. An antenna coupler improves in-vehicle reception of the mobile phone.

GSM antenna

A compatible GSM antenna enables optimized wireless connections.

You may purchase a GSM antenna from an authorized Nokia dealer.

If you have installed an external antenna, remember that in order to comply with RF exposure requirements for mobile transmitting devices, a minimum distance of 7.8 inches must be maintained between the antenna and all persons.

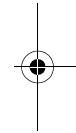
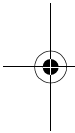



2 Installation

• SAFETY INFORMATION

The basic safety guidelines set out below are to be observed when installing the Advanced Car Kit CK-7W.

Warning:

- Only qualified personnel should service the Advanced Car Kit CK-7W or install it in a vehicle using the approved original Nokia parts supplied in the sales package. Faulty installation or service may be dangerous and may invalidate any warranty which may apply to the unit. End users should remember that the Advanced Car Kit CK-7W comprises complex technical equipment that requires professional installation using special tools and expert know-how.
- Note that the instructions contained in this installation guide are general guidelines which apply for the installation of the Advanced Car Kit CK-7W in an automobile. However, due to the wide variety of car types and models available on the market, this guide cannot consider the individual technical requirements relevant for any particular vehicle. Contact the vehicle manufacturer for further detailed information about the vehicle in question.
- Make sure that the car ignition is off and disconnect the car battery before beginning with the installation work and ensure that it cannot be reconnected inadvertently.
- Remember that modern automotive systems include on-board computers where key vehicle parameters are stored. Improper disconnection of the car battery may cause loss of data, necessitating extensive effort for re-initialisation of the system. If you have any concerns, contact your car dealer before any installation work is done.
- Do not wire Advanced Car Kit CK-7W equipment to the high-voltage lines of the ignition system.
- All equipment must be mounted so that it does not interfere with the operation of the vehicle.

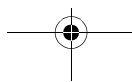
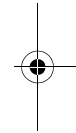
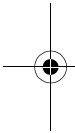



Installation

- Your service technician may be able to provide you with information on alternatives for mounting the equipment suitably in your vehicle without requiring boreholes.
- The mount for the phone holder is to be fixed to the dashboard or to any other location in the cockpit area where the display is clearly visible for the user but does not impair control or operation of the vehicle. The keypad should be within easy reach of the user.
- Make sure not to impact the steering or braking systems or other key systems essential for proper operation of the car when installing Advanced Car Kit CK-7W equipment. Check to make sure that deployment of the airbag is not blocked or impaired in any way.
- Do not smoke when working on the car. Make sure that there is no source of fire or flame nearby.
- Take care not to cause damage to electrical cables, fuel or brake lines or safety equipment during installation work.
- RF signals may affect improperly installed or inadequately shielded electronic systems in motor vehicles (e.g. electronic fuel injection systems, electronic anti-skid braking systems, electronic speed control systems, airbag systems). Should you note a fault or change in the operation of such a system, contact your car dealer.
- Ensure that cables are placed so that they will not be subjected to mechanical wear and tear (e.g. not laid under car seats or over sharp edges).

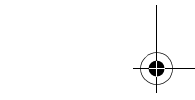
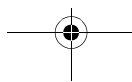
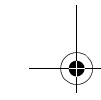
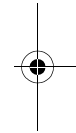
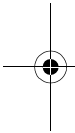

- **CONFIGURATION**

In principle, the Advanced Car Kit CK-7W offers two different basic configurations for installation:

Connecting a mobile phone using Bluetooth wireless technology

To be able to establish a connection from a compatible mobile phone to the handsfree unit, both devices first have to be paired.

A compatible mobile phone supporting Bluetooth wireless technology is required for this setup.

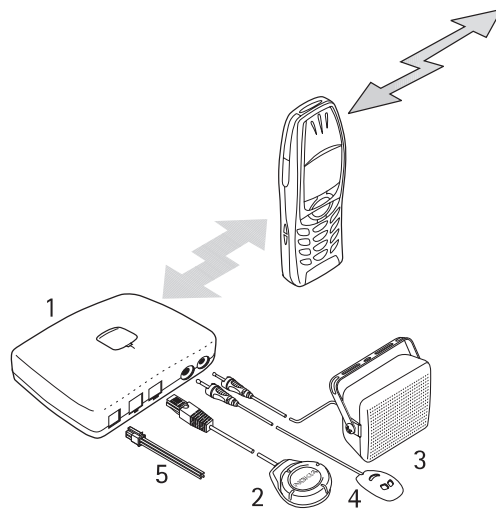

Installation

Connecting a mobile phone using the data cable and a phone holder

When connected via the data cable, the compatible mobile phone is ready for operation with the Advanced Car Kit when placed into the phone holder.

Depending on your mobile phone and your vehicle equipment, enhancements such as a phone holder, antenna coupler or external antenna may be required.

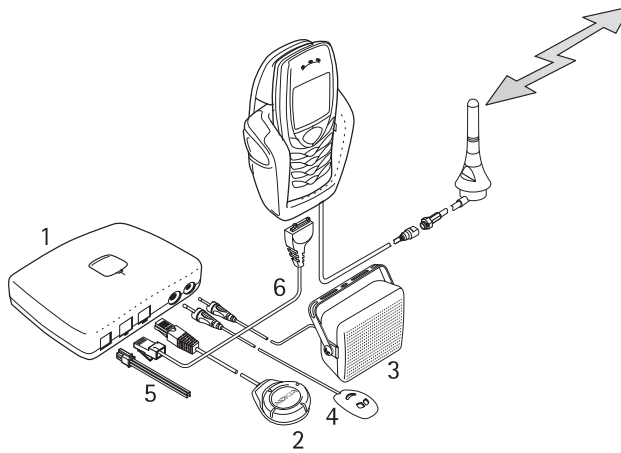

• INSTALLING THE ADVANCED CAR KIT CK-7W

See "Introduction" on page 2 for an example of a suitable installation of the Advanced Car Kit equipment.

Handsfree unit

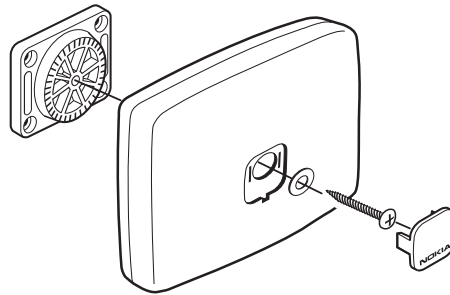

When installing the handsfree unit, ensure that the cables for the microphone and loudspeaker will reach the places you intend to mount these components.

Take care not to mount the handsfree unit inside a closed metal housing or in a place in the car where it would be shielded from radio waves, as this may impair the use of the Bluetooth feature.

To mount the unit, first attach the mounting plate supplied with the Advanced Car Kit and then secure the handsfree unit using the screw that goes through the unit. Finally, insert the cover imprinted with the Nokia logo into the recess and press it into place.

Remote control button

The remote control button should be located so that it is within easy reach of the user. However, ensure that it is placed so that the cable for connection to the handsfree unit can be mounted. A suitable mounting position for the remote control button may be on the console between the front seats.

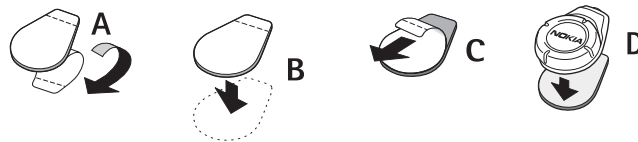



Installation

To mount the remote control button, use the hook and loop tape provided. First detach the two parts of the pads from each other. Attach the pad with the loops first: peel off the protective sheet from the adhesive side (A) and attach the pad to the desired location in your car (B). Make sure that the surface where you intend to attach the pad is dry and free from dirt and dust.

Attach the pad with the hooks next: peel off the protective sheet from the adhesive side (C) and attach the pad to the underside of the remote control button.

Press the remote control button (D) firmly onto the loop pad mounted in the car.

Loudspeaker

To ensure good acoustic quality, mount the loudspeaker so that it is pointed in the user's direction. We recommend that you mount the loudspeaker a minimum distance of 3.28 feet away from the microphone to avoid feedback.

The Advanced Car Kit also supports connection to a compatible car radio system. If you wish to use the car radio installed in your vehicle with the Advanced Car Kit for audio output, ask your service technician for professional advice.

Connect the loudspeaker or a compatible car radio system to the "SPEAKER" output.

Microphone

Careful selection of the mounting location of the microphone can increase the quality of voice transmission.

Mount the microphone approx. 11.8 inches from the user's head, and position it so that it points towards the user's mouth. Experience has shown that the best locations are near the rearview mirror or the sun visor. We recommend that you keep the microphone a minimum distance of 3.28 feet away from the Advanced Car Kit phone loudspeaker to avoid feedback.

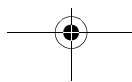
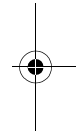
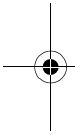

Take care to mount the microphone so that it is not exposed to air streams from the vents. Do not lay the microphone cable in the heating, ventilation or AC system. Use the double-sided adhesive tape supplied to fix the microphone, as this will prevent noise from the car body being transmitted into the interior.

Insert the plug into the "MIC" socket in the handsfree unit and turn it clockwise to lock it firmly.



Note: Use of any other microphone than the microphone supplied with the Advanced Car Kit (HFM-8) may impact the transmission quality.

Cable set

The wires making up the cable harness are to be connected as per the wiring diagram.

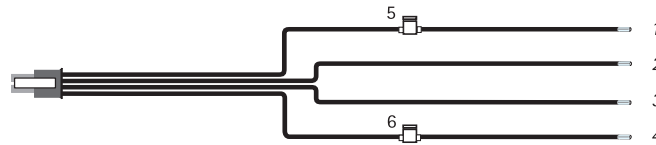

- Connect the black wire to the vehicle ground (GND).
- Connect the yellow wire to the MUTE connection of the car radio.

If your car radio does not have a mute connection, this line may remain unconnected. In this case, your car radio will not be muted automatically during a call.

An additional relay can be used to enable the car radio to be muted. When a call is accepted, the Advanced Car Kit switches the yellow line (MUTE) to ground, muting the car radio. When the call is ended, the yellow line is separated from ground and the car radio is unmuted.



Installation



- Connect the blue wire to the IGNS line of the car using the 1A fuse supplied.

Some vehicles do not come with an IGNS connection. This line is not necessary for operation of the Advanced Car Kit; the blue wire can be left unconnected. However, in this case, the Advanced Car Kit does not switch off automatically when the ignition is turned off. To prevent accidental draining of the car battery, the Advanced Car Kit automatically switches off after two minutes unless a mobile phone is connected over Bluetooth wireless technology or the data cable.

- Connect the red wire to the positive terminal of the 12V car battery using the 2A fuse supplied.

The four-pin plug of the cable set is plugged into the "DC" port of the handsfree unit.

Data cable

The data cable connects the handsfree unit with a compatible mobile phone, i.e. via the phone holder.

Plug one end of the cable into the "PHONE" socket in the handsfree unit and the other into the phone holder.

If the Advanced Car Kit is to be used only with Bluetooth wireless technology, the data cable does not need to be connected.

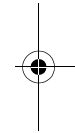
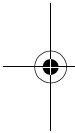

• FUNCTION TEST

After your Advanced Car Kit has been installed, it needs to be checked to ensure that it is working properly. When testing the operation of the equipment, also check that it has been mounted so that it in no way impairs the driver during operation of the vehicle.





3 Using the Advanced Car Kit

A compatible mobile phone can be connected to the Advanced Car Kit CK-7W in one of two ways: over a Bluetooth wireless connection or using a compatible phone holder with a cable.

• CONNECTING A MOBILE PHONE USING BLUETOOTH WIRELESS TECHNOLOGY

The first time you establish a wireless link from your Advanced Car Kit using Bluetooth technology, you will have to pair the handsfree unit with the compatible mobile phone that you are using. This only needs to be done once: after this the devices will automatically recognize each other and establish the link.



Note: If you wish to establish a connection using Bluetooth wireless technology, make sure that there is no mobile phone inserted in the phone holder.

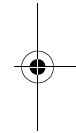
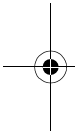

Pairing using a Bluetooth passcode

- 1 Make sure that the mobile phone is switched on and the battery is charged.
- 2 Switch on the Advanced Car Kit. For further information, see "Switching the Advanced Car Kit CK-7W on/off" on page 17.
- 3 Open the Bluetooth menu in the mobile phone and activate the Bluetooth function.
- 4 Make the required settings on the mobile phone to activate a search for Bluetooth devices within range. For further information on the settings required on your mobile phone, see the relevant user's guide.
- 5 Select Advanced Car Kit from the list of Bluetooth devices found.
- 6 When prompted, key in the Bluetooth passcode. You will find this code on the sticker attached to the front of this user's guide.

The Bluetooth passcode is a four-digit numeric code that corresponds to the last four digits in the serial number supplied with your Advanced Car Kit. You will find the serial number on the sticker attached to the handsfree unit.





Using the Advanced Car Kit

- 7 The mobile phone has now been paired with the Advanced Car Kit and is ready for operation.



Note: The Advanced Car Kit can only establish a Bluetooth wireless connection to one compatible mobile phone at a time. Therefore, you may need to end any existing Bluetooth wireless connection before connecting to a different mobile phone.

Automatic pairing with a compatible mobile phone

- 1 Make the appropriate settings in the mobile phone so that it will pair with your Advanced Car Kit without requiring separate acceptance or authorization. Your car kit can be paired with up to 8 compatible mobile phones. The settings for each of the mobile phones will be stored in the car kit memory for future use. For further information on the settings required on your mobile phone, see the relevant user guide.
- 2 Switch on the Advanced Car Kit.
- 3 The Advanced Car Kit now starts an automatic 30-second search for up to seven different mobile phone settings that have been paired and stored in its memory. The Advanced Car Kit, by default, pairs with the mobile phone that it paired with last. The active Bluetooth search is indicated by the flashing light on the remote control button.

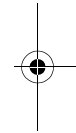
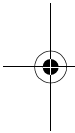

• CONNECTING A MOBILE PHONE OVER THE DATA CABLE

If you are using this form of connection, the mobile phone is ready for use with the Advanced Car Kit when placed into the phone holder; you do not need to pair the devices.

If a mobile phone is inserted into a phone holder connected to the Advanced Car Kit via the data cable, this phone is the active device and you will not be able to establish a connection to any device via Bluetooth wireless technology. Inserting a mobile phone that is currently involved in an active Bluetooth wireless connection into a phone holder connected to the Advanced Car Kit CK-7W will cause the Bluetooth wireless connection to be terminated automatically.

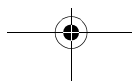



4 Operation

The Advanced Car Kit CK-7W can be controlled with the remote control button or operated using the keypad of a compatible mobile phone.

• REMOTE CONTROL BUTTON

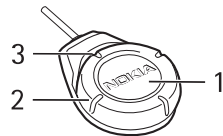

1 The button can be used as follows:

- Press
- Press and hold (approx. 1 second)
- Press twice briefly
- Press and hold for a long time (longer than 10 seconds)

2 The ring can be used as follows:

- Turn to the left
- Turn to the right

3 The indicator light has three states:

- On
- Flashing
- Off

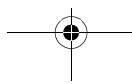
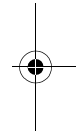
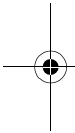



Operation

- **SWITCHING THE ADVANCED CAR KIT CK-7W ON/OFF**

If the ignition sense cable has been connected, the Advanced Car Kit will automatically switch on when you turn on the ignition of your car. The indicator light goes on to show that the Advanced Car Kit is activated. When you turn off the car ignition, you deactivate the Advanced Car Kit and the indicator light goes off. To verify that the Ignition Sense (IGNS) works with your car and phone, check your phone's user guide for compatibility.

If the Advanced Car Kit has been installed without connecting the ignition sense cable (IGNS), to switch the Advanced Car Kit on, either press the button briefly or insert a compatible mobile phone in the phone holder, if one has been installed.



Note: If the Advanced Car Kit has been installed without using the Ignition Sense (IGNS) cable, when switched on, it will stay in service as long as a compatible mobile phone remains in the phone holder.

If there is currently no connection to a mobile phone, the Advanced Car Kit will switch itself off after 2 minutes.

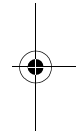
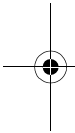

- **OPERATING THE ADVANCED CAR KIT CK-7W**

You can use the remote control button to access the following phone features:

Accepting a call

To accept an incoming call, press the button.

Ending a call

To end an active call, press the button.

Rejecting a call

If you do not wish to accept a call, press and hold the button.

Making a call

Select the desired entry from the phonebook of the mobile phone or key in the desired number on your mobile phone.





Redialing

To redial a number that you have recently called, press the button twice briefly.

Voice dialing

You can use voice tags that you have saved in your mobile phone:

- 1 To start voice dialing, press and hold the button until you hear a tone.
- 2 Say the voice tag.
- 3 The mobile phone plays the voice tag and dials the corresponding phone number.

For details on using voice dialing, see the user's guide of your mobile phone.



Note: Some mobile phones may not support all the functions described in this user's guide.

Adjusting the volume

To adjust the loudspeaker volume, turn the ring.

Manual search for Bluetooth devices

If you have not established a connection to a mobile phone, you can start a manual search for a mobile phone that supports Bluetooth wireless technology.

To activate the Bluetooth search feature in the Advanced Car Kit, press and hold the button.

If the search for Bluetooth devices is active, the indicator light will begin flashing.

Resetting paired Bluetooth devices

The Advanced Car Kit saves the last Bluetooth device that it has been paired with.

The list of paired Bluetooth devices can be erased. To erase the list, the Advanced Car Kit must be switched off (indicator light goes off):

Press and hold the button until a signal tone indicates that the list has been erased.

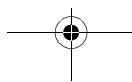
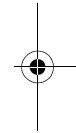
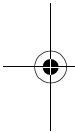



Operation

Switching from handsfree mode to the mobile phone

- If you have connected a compatible mobile phone to the Advanced Car Kit using the data cable, take the phone out of the holder to switch operation from the car kit's handsfree mode over to the mobile phone.
- To change back to the car kit's handsfree mode, replace the mobile phone in the holder. The mobile phone is now used in handsfree mode via the Advanced Car Kit.
- If you have connected a compatible mobile phone to the Advanced Car Kit using Bluetooth technology, you can switch the active call between the Advanced Car Kit and the mobile phone or vice versa. Press and hold the button or use the corresponding function in your mobile phone.

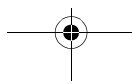
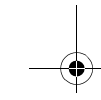
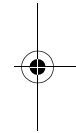
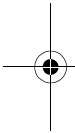



Care and maintenance

Your Advanced Car Kit CK-7W is a product of superior design and craftsmanship and should be treated with care. The suggestions below will help you to fulfill any warranty obligations and to enjoy this product for many years.

- Keep all enhancements out of the reach of small children.
- Keep the Advanced Car Kit dry. Precipitation, humidity and all types of liquids or moisture can contain minerals that will corrode electronic circuits.
- Do not use or store the Advanced Car Kit in dusty, dirty areas. Its parts can be damaged.
- Do not attempt to open the Advanced Car Kit. Non-expert handling may damage it.
- Do not use harsh chemicals, cleaning solvents or strong detergents to clean the Advanced Car Kit or the remote control button.
- Do not paint the Advanced Car Kit or the remote control button. Paint can clog the moving parts and prevent proper operation.

If the Advanced Car Kit or the remote control button is not working properly, take the defective part to your nearest qualified service facility. The personnel there will assist you and, if necessary, arrange for service.

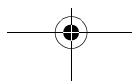
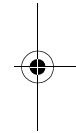
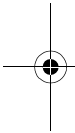



Nokia One-Year Limited Warranty (U.S.)

Nokia Inc. ("Nokia") warrants that this cellular phone ("Product") is free from defects in material and workmanship that result in Product failure during normal usage, according to the following terms and conditions:

- 1 The limited warranty for the Product extends for ONE (1) year beginning on the date of the purchase of the Product. This one year period is extended by each whole day that the Product is out of your possession for repair under this warranty.
- 2 The limited warranty extends only to the original purchaser ("Consumer") of the Product and is not assignable or transferable to any subsequent purchaser/end-user.
- 3 The limited warranty extends only to Consumers who purchase the Product in the United States of America.
- 4 During the limited warranty period, Nokia will repair, or replace, at Nokia's sole option, any defective parts, or any parts that will not properly operate for their intended use with new or refurbished replacement items if such repair or replacement is needed because of product malfunction or failure during normal usage. No charge will be made to the Consumer for any such parts. Nokia will also pay for the labor charges incurred by Nokia in repairing or replacing the defective parts. The limited warranty does not cover defects in appearance, cosmetic, decorative or structural items, including framing, and any non-operative parts. Nokia's limit of liability under the limited warranty shall be the actual cash value of the Product at the time the Consumer returns the Product for repair, determined by the price paid by the Consumer for the Product less a reasonable amount for usage. Nokia shall not be liable for any other losses or damages. These remedies are the Consumer's exclusive remedies for breach of warranty.
- 5 Upon request from Nokia, the Consumer must prove the date of the original purchase of the Product by a dated bill of sale or dated itemized receipt.

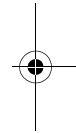
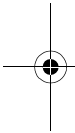



- 6** The Consumer shall bear the cost of shipping the Product to Nokia in Melbourne, Florida. Nokia shall bear the cost of shipping the Product back to the Consumer after the completion of service under this limited warranty.
- 7** The Consumer shall have no coverage or benefits under this limited warranty if any of the following conditions are applicable:

 - a)** The Product has been subjected to abnormal use, abnormal conditions, improper storage, exposure to moisture or dampness, unauthorized modifications, unauthorized connections, unauthorized repair, misuse, neglect, abuse, accident, alteration, improper installation, or other acts which are not the fault of Nokia, including damage caused by shipping.
 - b)** The Product has been damaged from external causes such as collision with an object, or from fire, flooding, sand, dirt, windstorm, lightning, earthquake or damage from exposure to weather conditions, an Act of God, or battery leakage, theft, blown fuse, or improper use of any electrical source, damage caused by computer or internet viruses, bugs, worms, Trojan Horses, cancelbots or damage caused by the connection to other products not recommended for interconnection by Nokia.
 - c)** Nokia was not advised in writing by the Consumer of the alleged defect or malfunction of the Product within fourteen (14) days after the expiration of the applicable limited warranty period.
 - d)** The Product serial number plate or the enhancement data code has been removed, defaced or altered.
 - e)** The defect or damage was caused by the defective function of the cellular system or by inadequate signal reception by the external antenna, or viruses or other software problems introduced into the Product.
- 8** Nokia does not warrant uninterrupted or error-free operation of the Product. If a problem develops during the limited warranty period, the Consumer shall take the following step-by-step procedure:

 - a)** The Consumer shall return the Product to the place of purchase for repair or replacement processing.

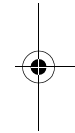
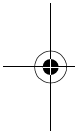



- b)** If "a" is not convenient because of distance (more than 50 miles) or for other good cause, the Consumer shall ship the Product prepaid and insured to:
Nokia Inc., Attn: Repair Department
795 West Nasa Blvd.
Melbourne, FL 32901
- c)** The Consumer shall include a return address, daytime phone number and/or fax number, complete description of the problem, proof of purchase and service agreement (if applicable). Expenses related to removing the Product from an installation are not covered under this limited warranty.
- d)** The Consumer will be billed for any parts or labor charges not covered by this limited warranty. The Consumer will be responsible for any expenses related to reinstallation of the Product.
- e)** Nokia will repair the Product under the limited warranty within 30 days after receipt of the Product. If Nokia cannot perform repairs covered under this limited warranty within 30 days, or after a reasonable number of attempts to repair the same defect, Nokia at its option, will provide a replacement Product or refund the purchase price of the Product less a reasonable amount for usage. In some states the Consumer may have the right to a loaner if the repair of the Product takes more than ten (10) days. Please contact the Customer Service Center at Nokia at the telephone number listed at the end of this warranty if you need a loaner and the repair of the Product has taken or is estimated to take more than ten (10) days.
- f)** If the Product is returned during the limited warranty period, but the problem with the Product is not covered under the terms and conditions of this limited warranty, the Consumer will be notified and given an estimate of the charges the Consumer must pay to have the Product repaired, with all shipping charges billed to the Consumer. If the estimate is refused, the Product will be returned freight collect. If the Product is returned after the expiration of the limited warranty period, Nokia's normal service policies shall apply and the Consumer will be responsible for all shipping charges.

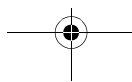
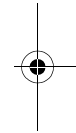
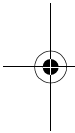



- 9** You (the Consumer) understand that the product may consist of refurbished equipment that contains used components, some of which have been reprocessed. The used components comply with Product performance and reliability specifications.
- 10** ANY IMPLIED WARRANTY OF MERCHANTABILITY, OR FITNESS FOR A PARTICULAR PURPOSE OR USE, SHALL BE LIMITED TO THE DURATION OF THE FOREGOING LIMITED WRITTEN WARRANTY. OTHERWISE, THE FOREGOING LIMITED WARRANTY IS THE CONSUMER'S SOLE AND EXCLUSIVE REMEDY AND IS IN LIEU OF ALL OTHER WARRANTIES, EXPRESS OR IMPLIED. NOKIA SHALL NOT BE LIABLE FOR SPECIAL, INCIDENTAL, PUNITIVE OR CONSEQUENTIAL DAMAGES, INCLUDING BUT NOT LIMITED TO LOSS OF ANTICIPATED BENEFITS OR PROFITS, LOSS OF SAVINGS OR REVENUE, LOSS OF DATA, PUNITIVE DAMAGES, LOSS OF USE OF THE PRODUCT OR ANY ASSOCIATED EQUIPMENT, COST OF CAPITAL, COST OF ANY SUBSTITUTE EQUIPMENT OR FACILITIES, DOWNTIME, THE CLAIMS OF ANY THIRD PARTIES, INCLUDING CUSTOMERS, AND INJURY TO PROPERTY, RESULTING FROM THE PURCHASE OR USE OF THE PRODUCT OR ARISING FROM BREACH OF THE WARRANTY, BREACH OF CONTRACT, NEGLIGENCE, STRICT TORT, OR ANY OTHER LEGAL OR EQUITABLE THEORY, EVEN IF NOKIA KNEW OF THE LIKELIHOOD OF SUCH DAMAGES. NOKIA SHALL NOT BE LIABLE FOR DELAY IN RENDERING SERVICE UNDER THE LIMITED WARRANTY, OR LOSS OF USE DURING THE PERIOD THAT THE PRODUCT IS BEING REPAIRED.
- 11** Some states do not allow limitation of how long an implied warranty lasts, so the one year warranty limitation may not apply to you (the Consumer). Some states do not allow the exclusion or limitation of incidental and consequential damages, so certain of the above limitations or exclusions may not apply to you (the Consumer). This limited warranty gives the Consumer specific legal rights and the Consumer may also have other rights which vary from state to state.
- 12** Nokia neither assumes nor authorizes any authorized service center or any other person or entity to assume for it any other obligation or liability beyond that which is expressly provided for in this limited warranty including the provider or seller of any extended warranty or service agreement.

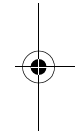
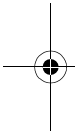



- 13** This is the entire warranty between Nokia and the Consumer, and supersedes all prior and contemporaneous agreements or understandings, oral or written, relating to the Product, and no representation, promise or condition not contained herein shall modify these terms.
- 14** This limited warranty allocates the risk of failure of the Product between the Consumer and Nokia. The allocation is recognized by the Consumer and is reflected in the purchase price.
- 15** Any action or lawsuit for breach of warranty must be commenced within eighteen (18) months following purchase of the Product.
- 16** Questions concerning this limited warranty may be directed to:
Nokia Inc.
Attn: Customer Service
7725 Woodland Center Blvd., Ste. 150
Tampa, FL 33614
Telephone: 1-888-NOKIA-2U (1-888-665-4228)
Facsimile: (813) 287-6612
TTY/TDD Users Only: 1-800-24-NOKIA (1-800-246-6542)
- 17** The limited warranty period for Nokia supplied attachments and enhancements is specifically defined within their own warranty cards and packaging.

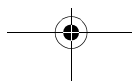
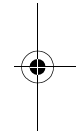
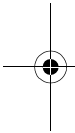



Nokia One-Year Limited Warranty (Canada)

Nokia warrants that this Nokia wireless device is free from defects in material and workmanship. The warranty period for the unit is twelve (12) months from the date of purchase OR fourteen (14) months from date of wholesale shipment from Nokia, OR fifteen (15) months from the date of manufacture by Nokia.

During the warranty period, Nokia will, at its option, repair or replace the defective product free of charge. Replacement Product may be either new or remanufactured or refurbished.

However, if Nokia determines that the warranty conditions cannot be applied, the purchaser will be billed for the repair and shipping.

EXCEPTIONS

This warranty is subject to the following exceptions:

- 1 Damage caused by a repair or an attempt to repair by other than a service centre authorized by Nokia will void the warranty;
- 2 This warranty covers normal consumer use and does not cover defects or damage to any product which, in the sole opinion of Nokia, has been subject to: improper storage, exposure to moisture or dampness, exposure to fire, sand, dirt, windstorm, lightning, or earthquake; to theft, battery leakage, unauthorized modification, misuse, neglect, abuse, misapplication, accident, alteration, improper installation, maladjustment of consumer controls, or abnormal operating conditions, or which has been attributable to acts of God;
- 3 This warranty does not cover defects or damages caused by a product which is not approved by Nokia to be connected to its device;
- 4 This warranty is applicable only to products bought through Nokia Products Ltd. in Ajax, Ontario, Canada, and sold either in Canada or Bermuda.

In no event shall Nokia be liable for incidental, special, or consequential damages, direct or indirect, loss of anticipated benefits or profits, loss of use of its device, resulting from the use of its device, or its enhancements, or arising from any breach of this warranty.

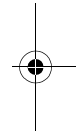
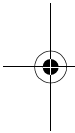



CLAIM PROCEDURE

In order to obtain warranty performance, return the defective unit to the Nokia Service Centre with transportation charges prepaid (Shipping of the repaired unit may be paid by Nokia, in which case Nokia shall have risk of loss or damage during this shipment).

The proof of date of purchase will be required before in-warranty service is rendered.

Maintenance and service may be obtained in any authorized service centre in Canada.

EXTENSION OF WARRANTY PERIOD

When a repair is made, an extra 90-day service warranty is given to the labour and parts of the repair concerned. If replacement of a faulty unit is applied, instead of repairing, this 90-day service warranty is applied to the replaced unit.

Besides this 90-day service warranty, the warranty repairs or replacements do not affect the original warranty conditions, which are determined by the date of purchase.

THE FOREGOING WARRANTY IS THE PURCHASER'S SOLE AND EXCLUSIVE REMEDY AND IS IN LIEU OF ALL OTHER WARRANTIES, EXPRESSED OR IMPLIED, INCLUDING BUT NOT LIMITED TO ANY IMPLIED WARRANTY OR MERCHANTABILITY OR FITNESS FOR A PARTICULAR PURPOSE OR USE.

Some provinces do not allow limitations on how long an implied warranty lasts, so the above limitations may not apply to you.

FOR WARRANTY SERVICE LOCATIONS, CONTACT YOUR SERVICE PROVIDER/ RETAILER/DEALER OR DIRECTLY TO:

NOKIA PRODUCTS LIMITED
601 Westney Road South
Ajax, Ontario L1S 4N7
Tel: 905-427-1373
1-888-226-6542
Website: www.nokia.ca

For products being returned to Nokia or its authorized service centres, the service provider/retailer/dealer shall prepay shipping charges, taxes, duties, insurance. Nokia shall have no risk for loss or damage during this shipment.

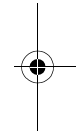
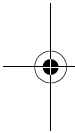

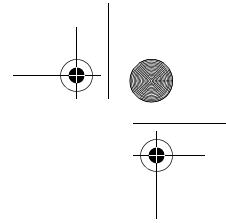
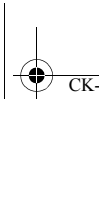
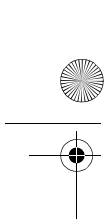

NOTES

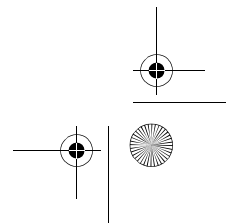
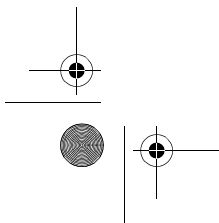
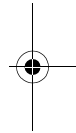
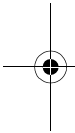

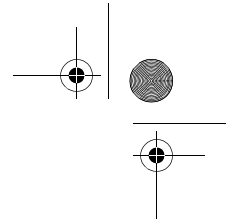
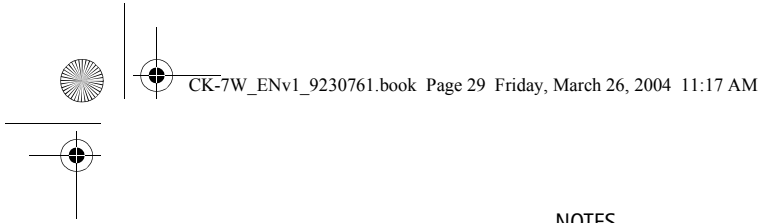

NOTES

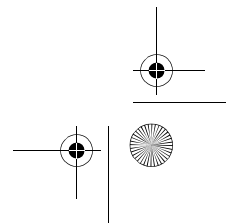
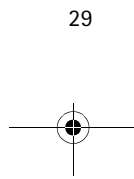
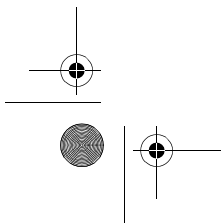
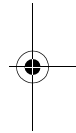
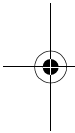

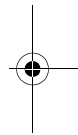
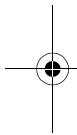
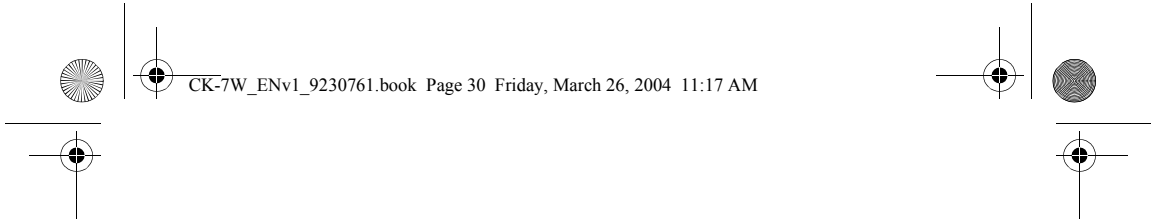

NOKIA

CONNECTING PEOPLE

© Nokia 2004. All rights reserved.

Nokia, Connecting People and the Original Enhancements logos are registered trademarks and/or trademarks of Nokia Corporation and/or its affiliates.

Version 1 Printed in Germany 3/04 9230761

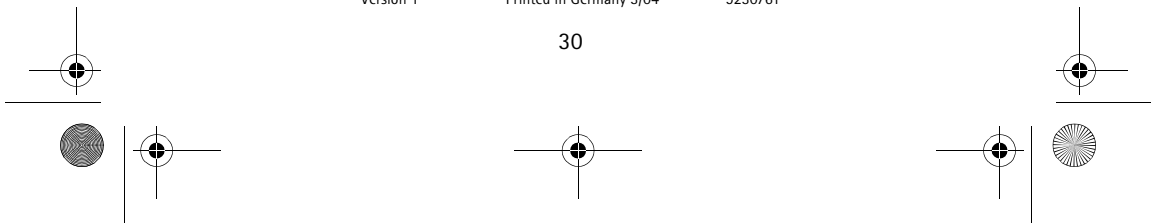

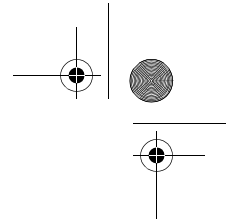
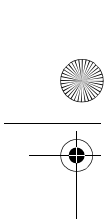

Manual del Usuario y de Instalación para el Equipo para Auto CK-7W

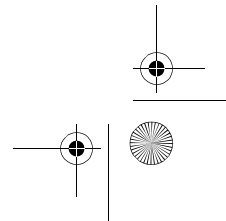
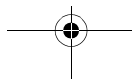
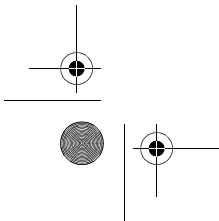
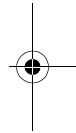
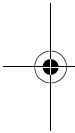



DECLARACIÓN DE CONFORMIDAD

Nosotros, NOKIA CORPORATION declaramos bajo nuestra propia responsabilidad que el producto Equipo para Auto CK-7W funciona en conformidad con las provisiones estipuladas en el Directivo de Consejo: 1999/5/EC. Se puede encontrar una copia de la Declaración de Conformidad en http://www.nokia.com/phones/declaration_of_conformity/.

CE 168

Copyright © 2004 Nokia. Todos los derechos reservados.

Se prohíbe la reproducción, transferencia, distribución o almacenamiento del contenido en parte o en su totalidad de este documento en cualquier forma sin el previo permiso escrito de parte de Nokia.

Nokia y Nokia Connecting People son marcas, registradas o no, de Nokia Corporation. Otros nombres de productos y compañías aquí mencionados podrían ser marcas, registradas o no, de sus respectivos propietarios.

Bluetooth es marca registrada de Bluetooth SIG, Inc.

Nokia opera bajo un sistema de desarrollo continuo. Nokia se reserva el derecho de hacer cambios y mejoras en cualquier producto descrito en este manual sin previo aviso.

BAJO NINGÚN CONCEPTO NOKIA SERÁ RESPONSABLE POR CUALQUIER PÉRDIDA DE DATOS O GANANCIAS O POR CUALQUIER OTRO DAÑO ESPECIAL O INCIDENTAL, POR CUALQUIER CAUSA DIRECTA O INDIRECTA.

El contenido de este documento está provisto "tal cual". Además de las exigidas por las leyes, no se emite ninguna otra garantía de ningún tipo, sea expresa o implícita, incluyendo, pero sin limitarse a, garantías implícitas de mercadeo y de capacidad para un propósito particular, en cuanto a la precisión, fiabilidad o contenido de este documento. Nokia se reserva el derecho de revisar este documento o retirarlo en cualquier momento sin previo aviso.

La disponibilidad de ciertos productos y servicios podrían variar por región. Consulte con su distribuidor Nokia local más cercano.

CONTROL DE EXPORTACIONES

Este producto contiene bienes, tecnología, o software exportados desde los Estados Unidos de América de acuerdo con los reglamentos de la Oficina de Administración de Exportaciones. Se prohíbe su desvío contraviniendo de las leyes de los EE.UU. o Canadá.

AVISO FCC/INDUSTRIA CANADIENSE

Este aparato cumple con la sección 15 de los reglamentos de la FCC. Su funcionamiento está sujeto a estas dos condiciones: (1) este dispositivo no podría causar interferencia peligrosa, y (2) este dispositivo debe aceptar cualquier interferencia recibida, incluso interferencias que podrían causar su funcionamiento no deseado.

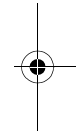
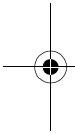



Contenido

Para su seguridad	1
Introducción	2
Su Equipo para Auto Nokia CK-7W	2
La tecnología inalámbrica Bluetooth	3
La contraseña Bluetooth	3
1 Para empezar	4
Resumen	4
El uso de los accesorios	5
2 Instalación	6
Información de seguridad	6
Configuración	8
Instalar el Equipo para Auto CK-7W	10
Prueba de funcionamiento	13
3 Configurar el Equipo para Auto CK-7W para su uso ...	14
Conexión del teléfono móvil vía la tecnología inalámbrica Bluetooth	14
Conexión con un teléfono móvil vía cable para datos	15
4 Funcionamiento	16
El botón de control remoto	16
Encender/apagar el Equipo para Auto CK-7W	17
Usar el Equipo para Auto CK-7W	17
Cuidado y mantenimiento	20

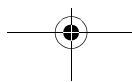
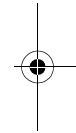
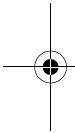

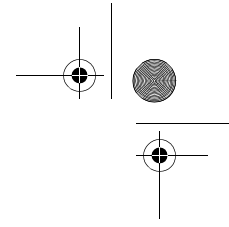
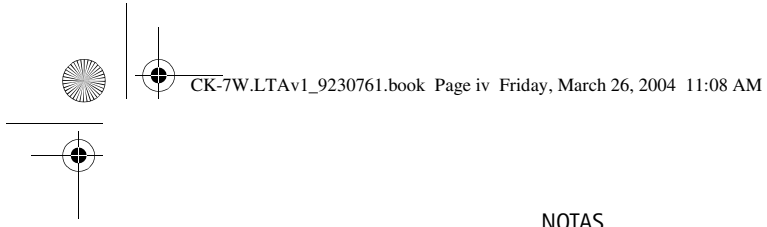

NOTAS

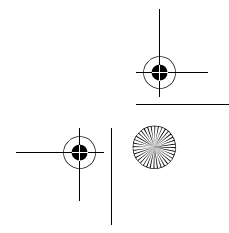
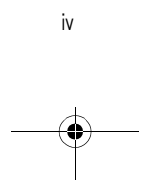
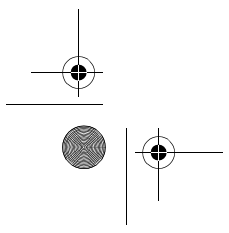
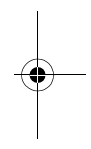
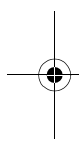



Para su seguridad

Lea esta información antes de utilizar su teléfono celular. El incumplimiento de estas normas puede ser peligroso o ilegal. Este manual del usuario da más información detallada.

Mantenga las minitarjetas SIM fuera del alcance de los niños.



LA SEGURIDAD DEL TRÁFICO ES LO MÁS IMPORTANTE

Recuerde que la seguridad del funcionamiento de un vehículo requiere la atención total de todos los motoristas. Sólo utilice su Equipo para Auto CK-7W si las condiciones del tráfico permiten su uso legal y compruebe si los reglamentos/leyes restringen el uso de teléfonos móviles mientras está conduciendo.



INTERFERENCIAS

Todos los teléfonos celulares pueden recibir interferencias que pueden afectar el rendimiento.



INSTALACIÓN Y SERVICIO ESPECIALIZADO

Sólo personal de servicio especializado debe instalar o reparar el equipo.



CONEXIÓN A OTROS DISPOSITIVOS

Cuando haga una conexión a cualquier dispositivo usando la tecnología Bluetooth, lea detenidamente el manual del usuario para instrucciones detalladas de seguridad. No conecte productos incompatibles.



CAMBIAR FUSIBLES

Reponga un fusible dañado con uno del mismo tipo y tamaño. No utilice un fusible con una potencia más alta.

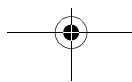
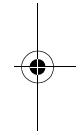
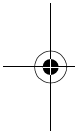

Introducción

- **SU EQUIPO PARA AUTO NOKIA CK-7W**

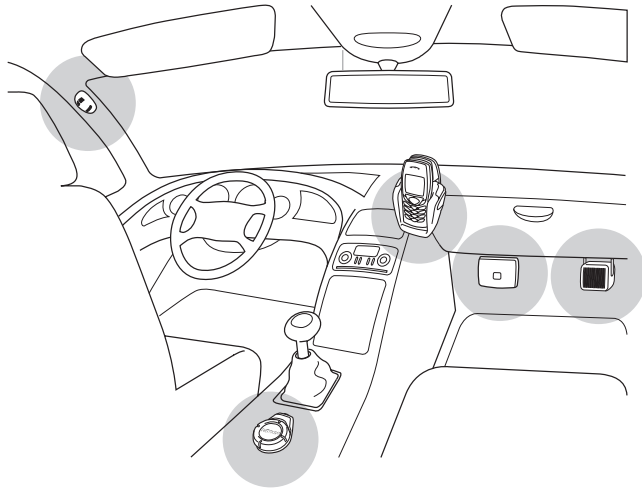

La instalación del Equipo para Auto CK-7W en la consola.

El Equipo para Auto de Nokia CK-7W fue desarrollado para ser instalado en los vehículos con el objeto de facilitar el manejo manos libres de los teléfonos móviles y el uso individual de las funciones del teléfono.

Se enfatiza en especial una instalación rápida y fácil. Hay dos formas de conectar un teléfono móvil al Equipo para Auto CK-7W: usando un soporte de teléfono opcional con un cable o vía una conexión inalámbrica Bluetooth.

En algunos países, el uso del Equipo para Auto CK-7W podría ser restringido por la ley. Observe las normativas y regulaciones aplicables.



• LA TECNOLOGÍA INALÁMBRICA BLUETOOTH

La tecnología inalámbrica Bluetooth es un estándar internacional para la comunicación inalámbrica de corto alcance. Le permite establecer una conexión inalámbrica dentro de un alcance de 9.9 metros (32.8 pies) entre su Equipo para Auto CK-7W y un dispositivo compatible.

El Equipo para Auto CK-7W está diseñado para ser usado con cualquier teléfono móvil compatible con el Perfil Bluetooth Manos Libres (Especificación Bluetooth 1.1).

La conexión inalámbrica entre los dispositivos compatibles establecida vía la tecnología Bluetooth es gratuita para el usuario. En algunos países pueden existir restricciones para el uso de dispositivos Bluetooth. Consulte con las autoridades locales.

• LA CONTRASEÑA BLUETOOTH

Cuando establezca por primera vez una conexión inalámbrica a un dispositivo usando la tecnología Bluetooth, deberá necesitar ingresar una contraseña para vincular los dispositivos.

La contraseña es un código de cuatro dígitos correspondiente a los últimos cuatro dígitos en el número de serie suministrado con su Equipo para Auto CK-7W.

El número de serie se encuentra en la etiqueta pegada a la unidad manos libres y en la calcomanía que viene con este manual del usuario.

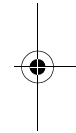
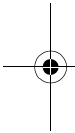

1 Para empezar

- RESUMEN

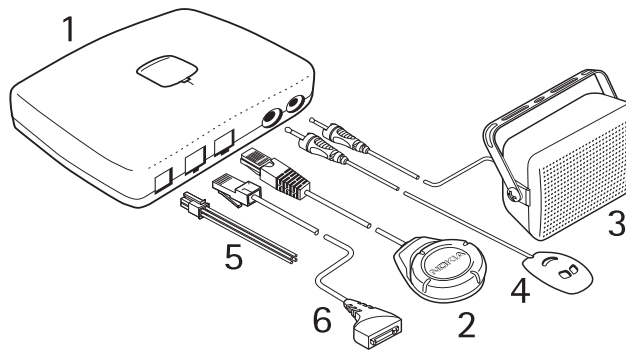

El Equipo para Auto CK-7W incluye los componentes indicados arriba.

- 1 La Unidad Manos Libres HF-5 con lámina de montaje MK-2
- 2 Botón de control remoto CU-7
- 3 Altavoz HFS-12
- 4 Micrófono HFM-8
- 5 Conjunto de Cable PCU-4
- 6 Cable para Datos CA-27



Para empezar



• EL USO DE LOS ACCESORIOS

Dependiendo de la instalación, hay una variedad de accesorios opcionales que están disponibles para optimizar su Equipo para Auto CK-7W. Antes de iniciar la instalación, consulte con un profesional sobre los accesorios que mejor servirían sus exigencias. Use sólo accesorios homologados. Recuerde que sólo los productos compatibles están conectados a su Equipo para Auto CK-7W.

Soporte para teléfono

Podría comprar un soporte para teléfono con su equipo para auto o por separado como un accesorio.

Necesitará un soporte para teléfono diseñado para un teléfono móvil para conectarse directamente a la unidad manos libres usando el cable para datos.

Acoplador de antena

Se puede comprar un acoplador de antena con su equipo para auto o como un accesorio por separado.

Se requiere un acoplador de antena para conectar una antena exterior. Una gama de acopladores de antena están disponibles en el mercado para los teléfonos móviles y soportes de teléfonos. Un acoplador de antena mejora la recepción del teléfono móvil dentro del vehículo.

Antena GSM

Una antena GSM compatible brinda conexiones inalámbricas óptimas.

Se puede adquirir una antena GSM en cualquier centro autorizado de distribución Nokia.

Si ha instalado una antena exterior, recuerde que para cumplir con los reglamentos sobre la exposición a la RF para dispositivos móviles, debe mantener una distancia de 19.8 cms (7.8 pulgadas) entre la antena y las personas.

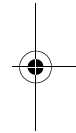
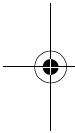



2 Instalación

• INFORMACIÓN DE SEGURIDAD

Observe las siguientes normativas de seguridad cuando instale el Equipo para Auto CK-7W.

Aviso:

- Sólo personal especializado debería reparar el Equipo para Auto CK-7W o instalarlo en un vehículo usando los componentes Nokia que vienen con el empaque de ventas. Una instalación o reparación defectuosa podría resultar peligrosa y podría anular cualquier garantía aplicable a la unidad. Los consumidores finales deberán recordar que el Equipo para Auto CK-7W consiste en equipos de alta tecnología que requieren herramientas especiales y experiencia especial para su instalación.
- Observe que las instrucciones contenidas en este manual de instalación son guías generales para la instalación del Equipo para Auto CK-7W en un vehículo. Sin embargo, debido a las variedades de tipos y modelos de automóviles disponibles en el mercado, este manual no puede reflejar los requerimientos técnicos apropiados para ningún vehículo en particular. Contacte al fabricante del vehículo para información detallada sobre un vehículo en específico.
- Asegúrese de apagar el vehículo y desconectar la batería antes de iniciar la instalación y de que no pueda ser reconectado antes de terminar la instalación.
- Recuerde que los sistemas modernos de automóviles incluyen computadoras que guardan los parámetros claves del vehículo. Una desconexión defectuosa de la batería del vehículo podría resultar en una pérdida de datos la cual va a necesitar un proceso extenso para la reiniciación del sistema. Para cualquier pregunta, contacte a su distribuidor antes de iniciar la instalación.
- No interconecte el Equipo para Auto CK-7W a líneas de alto voltaje del sistema de encendido.

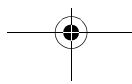
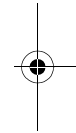
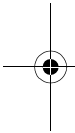



Instalación

- Instale todo el equipo para que no interfiera con el funcionamiento del vehículo.
- Su técnico de servicio podría darle las alternativas para instalar el equipo correctamente en su vehículo sin necesidad de taladrar.
- El soporte del teléfono es instalado en el tablero o en cualquier zona en el panel de control del vehículo el cual da una visibilidad al usuario sin interferir con el manejo o funcionamiento del auto. El teclado debe estar al alcance del usuario.
- Cuando instale el Equipo para Auto CK-7W asegúrese de no impactar los sistemas del volante o frenos, u otros sistemas esenciales para el funcionamiento debido del auto. Revise para no bloquear o perjudicar el despliegue del airbag.
- No fume cuando esté realizando trabajo en el vehículo. Asegúrese que no haya llamas o fuego alrededor.
- Tenga cuidado de no estropear los cables eléctricos y sistemas de gas, frenos, o equipos de seguridad durante la instalación.
- Las señales de RF pueden afectar los sistemas electrónicos que están incorrectamente instalados o inadecuadamente protegidos en los automóviles (ej., sistemas electrónicos de inyección directa, frenos antirresbalantes (antibloqueo), sistemas electrónicos de control de velocidad, o sistema de airbag). Si nota cualquier defecto o cambio en el funcionamiento de cualquier sistema, contacte al concesionario de su vehículo.
- Instale todos los cables de tal manera que estén protegidos del desgaste mecánico (ej: no instalarlos debajo del asiento o sobre filos agudos).

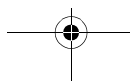
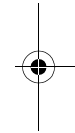
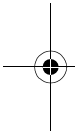

• CONFIGURACIÓN

El Equipo para Auto CK-7W provee dos configuraciones básicas de instalación:

Conexión con un teléfono móvil vía la tecnología inalámbrica Bluetooth

Para poder establecer una conexión con un teléfono móvil compatible, deberá vincular primero los dos dispositivos.

Se necesita un teléfono móvil compatible con la tecnología inalámbrica Bluetooth.

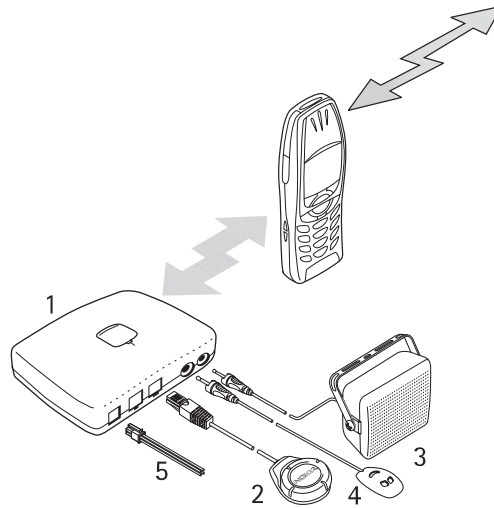

Instalación

Conexión de un teléfono móvil usando el cable para datos y un soporte de teléfono

Cuando esté conectado vía el cable para datos, el teléfono móvil compatible estará listo para su uso al colocarlo en el soporte.

Dependiendo de su teléfono móvil y equipo de vehículo, los accesorios, tal como un soporte de teléfono, acoplador para antena o antena exterior podrían ser requeridos.

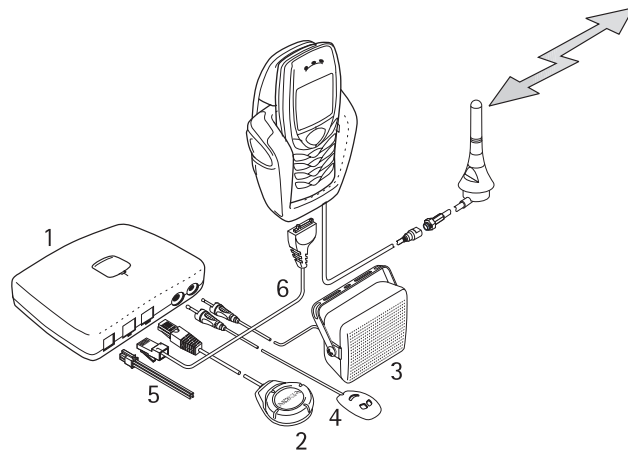

• INSTALAR EL EQUIPO PARA AUTO CK-7W

Vea "Introducción" pág. 2, para un ejemplo de una instalación apropiada para el Equipo para Auto CK-7W.

Unidad manos libres

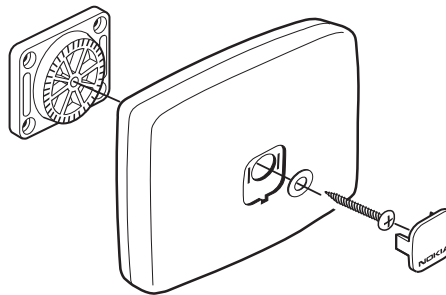

Cuando instale la unidad manos libres, cerciórese que los cables del micrófono y altavoz lleguen a donde quiere instalar estos componentes.

No instale la unidad manos libres dentro de una caja metálica o en un lugar dentro del vehículo donde estaría protegida de las radioondas, puesto que podría perjudicar el uso correcto de las ondas Bluetooth.

Para fijar la unidad, primero instale la lámina de montaje que viene con el Equipo para Auto CK-7W y después asegure la unidad manos libres usando los tornillos suministrados. Finalmente, inserte la cubierta impresa con el logotipo Nokia en la ranura y oprima hasta que encaje en su lugar.

El botón del control remoto

El botón de control remoto debería estar al alcance del usuario. Sin embargo, ubíquelo de tal forma que permita la instalación del cable de conexión a la unidad manos libres. Una ubicación idónea para el botón de control remoto podría ser la consola entre los dos asientos delanteros.

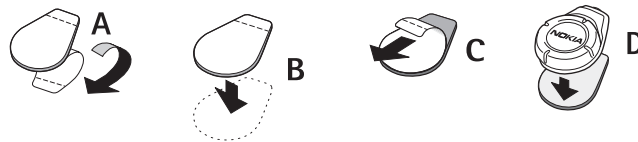



Instalación

Para instalar el botón de control remoto, use el gancho provisto. Primero, separe las dos almohadillas. Adjunte la almohadilla con los bucles: retire la capa protectora de la cinta adhesiva (A) y adjunte la almohadilla donde quiera instalarla en su auto (B). La superficie donde quiere adjuntar la almohadilla deberá estar seca y limpia.

Después, adjunte la almohadilla: retire la capa protectora del lado adhesivo (C) y adjunte la almohadilla al lado inferior del botón de control.

Oprima el botón de control remoto (D) firmemente en la almohadilla del bucle instalada en el auto.

Altavoz

Para asegurar la mejor calidad acústica, instale el altavoz hacia la dirección del usuario. Recomendamos que instale el altavoz a una distancia mínima de 100 cms (3.28 pies) del micrófono para evitar retroacción.

El Equipo para Auto CK-7W también respalda la conexión a un sistema compatible de radio para auto. Si desea usar la radio instalada en su auto con el Equipo para Auto CK-7W consulte con su técnico de servicio profesional.

Conecte el altavoz o sistema compatible de radio al conector de salida "SPEAKER".

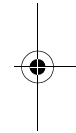
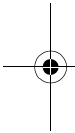

Micrófono

Una selección cuidadosa de la ubicación de instalación del micrófono puede maximizar la calidad de la transmisión de voz.

Instale el micrófono a una distancia aproximada de 30 cms (11.8 pulgadas) del usuario, y ubíquelo hacia la boca del usuario. La experiencia ha mostrado que los mejores sitios donde instalar el micrófono son cerca de la visera para el sol. Recomendamos que se mantenga una distancia mínima de 100 cms (3.28 pies) entre el micrófono y altavoz del micrófono del Equipo para Auto CK-7W para evitar la retroacción.



No instale el teléfono donde haya corrientes de aire de los conductos de ventilación. No coloque el cable del micrófono en el sistema de aire acondicionado, conductos de ventilación o calefacción. Use la cinta adhesiva de dos lados suministrada para fijar el micrófono; esto evita que el ruido del vehículo se transmita al interior del auto.

Inserte el enchufe en la salida "MIC" en la unidad manos libres y gírelo al sentido del reloj para fijarlo firmemente.

 **Nota:** El uso de cualquier otro micrófono que no sea el suministrado junto con el Equipo para Auto (HFM-8) podría afectar la calidad de la transmisión.

Equipo de cables

El conjunto de cableado consiste en los cables que se conectarán según el diagrama.

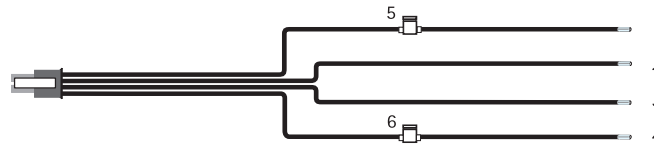

- Conecte el cable negro a la salida conexión a tierra (GND).
- Conecte el cable amarillo al puerto MUTE (enmudecido) de la radio del vehículo.

Si la radio de su vehículo no tiene una conexión MUTE, esta línea se deja desconectada. En este caso, la radio de su vehículo quedará enmudecida durante una llamada automáticamente.

Un relé (controlador) adicional se puede usar para enmudecer la radio del vehículo. Cuando se acepta una llamada, el Equipo para Auto CK-7W cambia a la línea amarilla (MUTE) a conexión a tierra, enmudeciendo la radio del vehículo. Tras la llamada, la línea amarilla queda separada de la conexión a tierra y la radio vuelve a su volumen original.



Instalación

- Conecte el cable azul a la línea IGNS del vehículo usando el fusible 1A suministrado.

Algunos vehículos no vienen con la conexión IGNS. Esta línea no es necesaria para el funcionamiento del Equipo para Auto CK-7W; el cable azul se puede dejar desconectado. Sin embargo, en tal caso, el Equipo para Auto CK-7W no se apaga automáticamente cuando el sensor de encendido está apagado. Para evitar el drenaje accidental de la batería del vehículo, el Equipo para Auto CK-7W se apaga automáticamente después dos minutos a no ser que un teléfono móvil esté conectado vía la conexión Bluetooth o cable para datos.

- Conecte el cable rojo a la salida positiva (+) de la batería 12V del vehículo usando el fusible 2A suministrado.

El conector de cuatro puntas del conjunto de cables es conectado al puerto "DC" de la unidad manos libres.

Cable para datos

El cable para datos conecta la unidad manos libres con el teléfono móvil compatible, es decir, al soporte para teléfono.

Enchufe uno de los extremos del cable al puerto "PHONE" en la unidad manos libres y el otro extremo al soporte para teléfono.

Si el Equipo para Auto CK-7W se usa solamente con la tecnología inalámbrica Bluetooth, no hace falta conectar el cable.

• PRUEBA DE FUNCIONAMIENTO

Tras instalar su Equipo para Auto CK-7W, es preciso que lo revise para asegurar un funcionamiento correcto. Cuando compruebe el funcionamiento del equipo, también revise la instalación, asegurándose que no obstruya al conductor durante la operación del vehículo.

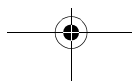
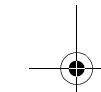
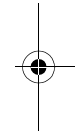
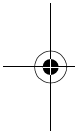



3 Configurar el Equipo para Auto CK-7W para su uso

Un teléfono móvil compatible se puede conectar al Equipo para Auto CK-7W de dos maneras: vía la tecnología inalámbrica Bluetooth o un soporte para teléfono compatible con cable.

- **CONEXIÓN DEL TELÉFONO MÓVIL VÍA LA TECNOLOGÍA INALÁMBRICA BLUETOOTH**

Cuando establezca por primera vez un enlace inalámbrico de su Equipo para Auto CK-7W vía la tecnología Bluetooth, tendrá que vincular la unidad manos libres con el teléfono móvil compatible que está usando. Sólo tiene que hacer este procedimiento una vez; después los dispositivos se aceptarán automáticamente y establecerán el enlace.



Nota: Si desea establecer una conexión vía la tecnología inalámbrica Bluetooth, cerciórese que no haya otro teléfono móvil en el soporte del teléfono.

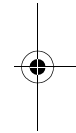
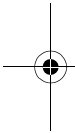

Vincular vía la contraseña Bluetooth

- 1 Asegúrese de encender el teléfono móvil y cargar la batería.
- 2 Encienda el Equipo para Auto CK-7W. Para más detalles, ver "Encender/Apagar el Equipo para Auto CK-7W" pág. 17.
- 3 Acceda al menú Bluetooth en el teléfono móvil y active la función Bluetooth.
- 4 Haga las configuraciones requeridas en el teléfono móvil para activar la búsqueda de dispositivos Bluetooth dentro de la cobertura. Para más información sobre las configuraciones requeridas para su teléfono móvil, refiérase al manual del usuario correspondiente.
- 5 Elija el Equipo para Auto CK-7W de la lista de los dispositivos Bluetooth encontrados.
- 6 Cuando se le indique, ingrese la contraseña Bluetooth. Este código se encuentra en la calcomanía adjunta a la portada de este manual del usuario.

La contraseña Bluetooth es un código de cuatro dígitos que corresponde a los últimos cuatro códigos del número de serie suministrado con su Equipo para Auto CK-7W. Este número de serie se encuentra en la etiqueta en la unidad manos libres.





Configurar el Equipo para Auto CK-7W para su uso

- 7 El teléfono móvil ya ha sido vinculado con el Equipo para Auto CK-7W y está listo para su funcionamiento.



Nota: El Equipo para Auto CK-7W sólo puede establecer a la vez una conexión inalámbrica Bluetooth a un teléfono móvil compatible. Entonces, debería finalizar cualquier conexión inalámbrica Bluetooth antes de conectarse a otro teléfono móvil.

Vincular automáticamente con un teléfono móvil compatible

- 1 Realice las configuraciones apropiadas en el teléfono móvil para vincularlo con su Equipo para Auto CK-7W sin requerir aceptación o autorización por separado. Es posible vincular su equipo para auto con hasta 8 teléfonos móviles compatibles. Las configuraciones para cada teléfono móvil serán guardadas en la memoria del equipo para auto para ser usadas en el futuro. Para más información sobre las configuraciones requeridas en su teléfono móvil, refiérase al manual correspondiente.
- 2 Encienda el Equipo para Auto CK-7W.
- 3 El Equipo para Auto CK-7W ahora inicia una búsqueda automática de 30 segundos para hasta siete distintas configuraciones de teléfonos móviles que han sido vinculados y guardados en la memoria. Por configuración original, el Equipo para Auto CK-7W, es emparejado con el último teléfono móvil vinculado. La búsqueda activa Bluetooth es indicada por una luz destellante en el botón del control remoto.

• CONEXIÓN CON UN TELÉFONO MÓVIL VÍA CABLE PARA DATOS

Si está usando este método de conexión, el teléfono móvil está listo para uso con el Equipo para Auto CK-7W al colocarlo en el soporte para teléfonos; no hace falta vincular los dispositivos.

Si se coloca un teléfono móvil en el soporte para teléfonos conectado al Equipo para Auto CK-7W vía el cable para datos, este teléfono es el dispositivo activo y no podrá establecer una conexión con ningún otro dispositivo vía Bluetooth. Cuando coloque un teléfono móvil con conexión Bluetooth en el soporte (de teléfono) que está conectado al Equipo para Auto CK-7W, la conexión inalámbrica Bluetooth será finalizada.

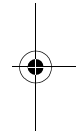
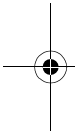

4 Funcionamiento

El Equipo para Auto CK-7W puede ser controlado vía el botón del control remoto o el teclado de un teléfono móvil compatible.

• EL BOTÓN DE CONTROL REMOTO

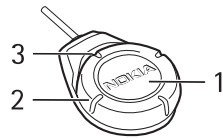

1 Se puede manejar el botón, siguiendo estos pasos:

- Oprimir
- Mantener oprimido (aproximadamente 1 segundo)
- Oprimir dos veces brevemente
- Mantener oprimido por más tiempo (más de 10 segundos)

2 El timbrado puede indicar:

- Girar a la izquierda
- Girar a la derecha

3 La luz indicadora tiene tres estados:

- Encender
- Destellante
- Apagar

Funcionamiento

• **ENCENDER/APAGAR EL EQUIPO PARA AUTO CK-7W**

Si el cable para ignición ha sido conectado, el Equipo para Auto CK-7W se encenderá automáticamente cuando encienda el sensor de encendido de su vehículo. La luz indicadora queda encendida para mostrar que el Equipo para Auto CK-7W está activado. Cuando apague el sensor de encendido del vehículo, desactivará el Equipo para Auto CK-7W y la luz indicadora se apaga. Para comprobar que el sensor de encendido (IGNS) funciona con su auto y teléfono, refiérase al manual del usuario para saber la compatibilidad.

Si el Equipo para Auto CK-7W ha sido instalado sin conectar el cable del sensor de encendido (IGNS), para encender el Equipo para Auto CK-7W, oprima el botón brevemente o coloque un teléfono móvil compatible en el soporte, si tiene uno instalado.



Nota: Si el Equipo para Auto CK-7W ha sido instalado sin usar el cable del Sensor de encendido (IGNS), al encenderlo, éste quedará funcionando mientras un teléfono móvil compatible este puesto en el soporte para teléfono.

Si existe una conexión a un teléfono móvil actualmente, el Equipo para Auto CK-7W se apagará en 2 minutos.

• **USAR EL EQUIPO PARA AUTO CK-7W**

Puede usar el botón de control remoto para acceder a las siguientes funciones del teléfono:

Aceptar una llamada

Para aceptar una llamada, oprima el botón.

Finalizar una llamada

Para finalizar una llamada, oprima el botón.

Rechazar una llamada

Para rechazar una llamada, mantenga oprimido el botón.

Hacer llamadas

Elija el ingreso en el directorio del teléfono móvil o marque el número deseado.



Remarcar

Para volver a marcar un número recién llamado, oprima el botón dos veces rápidamente.

Marcación por voz

Podrá usar etiquetas de voz que haya guardado en su teléfono móvil:

- 1 Para iniciar la marcación por voz, mantenga oprimido el botón hasta que oiga una señal.
- 2 Diga la etiqueta de voz.
- 3 El teléfono móvil reproduce la etiqueta de voz y marca el número correspondiente.

Para detalles sobre la marcación por voz, refiérase al manual del usuario de su teléfono.



Nota: Es posible que ciertos teléfonos móviles no respalden las funciones descritas en este manual del usuario.

Ajustar el volumen

Para ajustar el volumen del altavoz, gire el anillo.

Buscar los dispositivos Bluetooth manualmente

Si ha establecido una conexión a un teléfono móvil, puede empezar a buscar manualmente un teléfono móvil que respalde la tecnología inalámbrica Bluetooth.

Para activar la búsqueda Bluetooth en el Equipo para Auto CK-7W, mantenga oprimido el botón.

Si la búsqueda de dispositivos Bluetooth está activada, la luz indicadora empieza a destellar.

Reconfigurar los dispositivos Bluetooth vinculados

El Equipo para Auto CK-7W guarda el último dispositivo Bluetooth que fue vinculado con el mismo.

Se puede borrar la lista de los dispositivos vinculados. Para borrar la lista, apague el Equipo para Auto CK-7W (la luz indicadora se apaga):

Mantenga oprimido el botón hasta que una señal indique que la lista ha sido borrada.

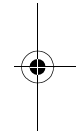
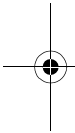



Funcionamiento



Cambiar de la modalidad manos libres al teléfono móvil

- Si ha conectado un teléfono móvil compatible al Equipo para Auto CK-7W vía el cable para datos, levante el teléfono del soporte para activar el teléfono móvil con la función manos libres del equipo para auto.
- Para regresar a la modalidad manos libres del Equipo para Auto CK-7W, recolóque el teléfono en el soporte. El teléfono móvil ya está en la modalidad manos libres vía el Equipo para Auto CK-7W.
- Si ha conectado un teléfono móvil compatible al Equipo para Auto CK-7W vía Bluetooth, puede intercambiar la llamada activa entre el Equipo para Auto CK-7W y el teléfono móvil. Mantenga oprimido el botón o use la función correspondiente en su teléfono móvil.

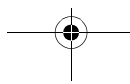
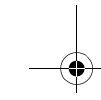
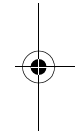
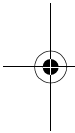



Cuidado y mantenimiento

Su Equipo para Auto CK-7W es un producto de alto diseño y tecnología y debería ser usado con cuidado. Las siguientes sugerencias le ayudarán a cumplir con cualquier obligación de garantía, y a disfrutar de este producto por muchos años.

- Mantenga todos los accesorios fuera del alcance de los niños.
- Mantenga el Equipo para Auto CK-7W seco. Las precipitaciones, la humedad y los líquidos contienen minerales que corroen los circuitos electrónicos.
- No use ni almacene el Equipo para Auto CK-7W en lugares polvorientos o sucios. Ello podría dañar sus partes móviles.
- No trate de abrir el Equipo para Auto CK-7W. Un manejo inexperto puede dañarlo.
- No use productos químicos abrasivos, solventes de limpieza ni detergentes para limpiar el Equipo para Auto CK-7W o el botón de control remoto.
- No pinte el Equipo para Auto CK-7W o el botón de control remoto. La pintura puede bloquear las partes móviles e impedir un funcionamiento apropiado.

Si el Equipo para Auto CK-7W o el botón de control remoto no funciona, llévelo a su centro de servicio especializado más cercano. El personal allí le asistirá, y si es necesario, le orientará sobre su reparación.

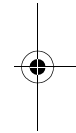
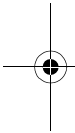

NOKIA

CONNECTING PEOPLE

© Nokia 2004. Todos los derechos reservados.

Nokia, Connecting People y el logo Original Enhancements son marcas, registradas o no, de Nokia Corporation y/o sus afiliadas.

Edición 1 Impreso en Alemania 03/04 9230761



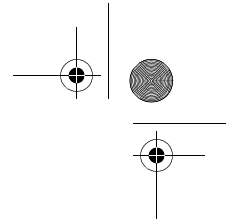
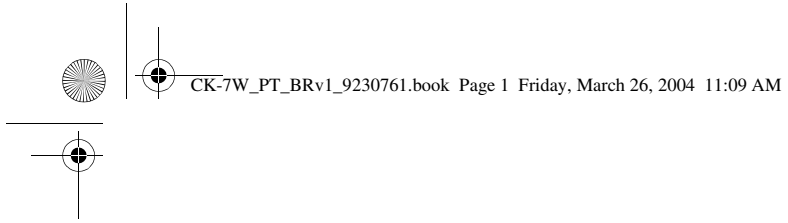

Kit Veicular CK-7W

Guia do Usuário

Instalação

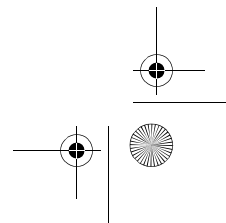
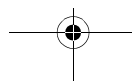
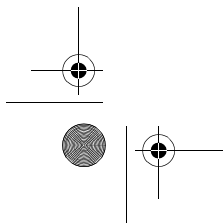
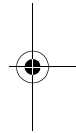
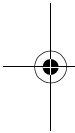



INFORMAÇÕES LEGAIS

Copyright © 2004 Nokia. Todos os direitos reservados.

É proibido reproduzir, transferir, distribuir ou armazenar parte desta informação ou toda a informação contida neste documento, em qualquer meio, sem a autorização prévia e por escrito da Nokia.

Os logos Nokia e Nokia Connecting People são marcas comerciais ou marcas registradas da Nokia Corporation. Os demais nomes e/ou marcas de produtos mencionados neste documento são marcas ou marcas registradas de seus respectivos proprietários.

Bluetooth é marca registrada da Bluetooth SIG, Inc.

A Nokia opera sob uma orientação de desenvolvimento contínuo.

A Nokia reserva-se o direito de fazer alterações nos produtos ou especificações descritos neste documento sem prévio aviso.

EM NENHUM CASO, A NOKIA SERÁ RESPONSÁVEL POR PERDA DE DADOS, RENDIMENTOS, OU POR QUALQUER OUTRO DANO EXTRAORDINÁRIO, INCIDENTAL, CONSEQUENTE OU INDIRETO, NÃO OBSTANTE A CAUSA.

O conteúdo deste documento é oferecido "no estado". A não ser em casos em que a lei em vigor o exija, nenhuma garantia, expressa ou implícita, incluindo, porém não limitada, às garantias de negociabilidade ou aptidão para um propósito determinado, é oferecida em relação à precisão, confiabilidade ou conteúdo deste documento. A Nokia reserva-se o direito de revisar este documento, ou retirá-lo do mercado, sem aviso prévio.

A disponibilidade de certos produtos e serviços poderá depender da área em que o usuário se encontrar. Consulte a Central de Atendimento Nokia.

CONTROLES DE EXPORTAÇÃO

Este produto contém artigos, tecnologia ou software que só podem ser exportados dos Estados Unidos da América de acordo com regulamentos da Secretaria de Exportação (Export Administration). Proíbe-se qualquer uso contrário às leis dos E.U.A.

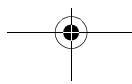
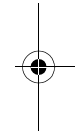
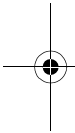



Este produto atende os limites de exposição da Taxa de Absorção Específica referente a campos elétricos, magnéticos e eletro-magnéticos de radiofrequência adotados pela ANATEL, de acordo com a Resolução 303/02.

"Este equipamento opera em caráter secundário, isto é, não tem direito à proteção contra interferência prejudicial, mesmo de estações do mesmo tipo, e não pode causar interferência a sistemas operando em caráter primário."

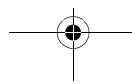
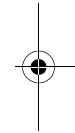
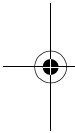

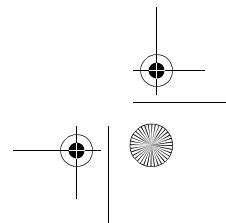
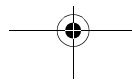
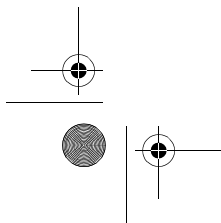
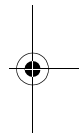
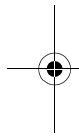
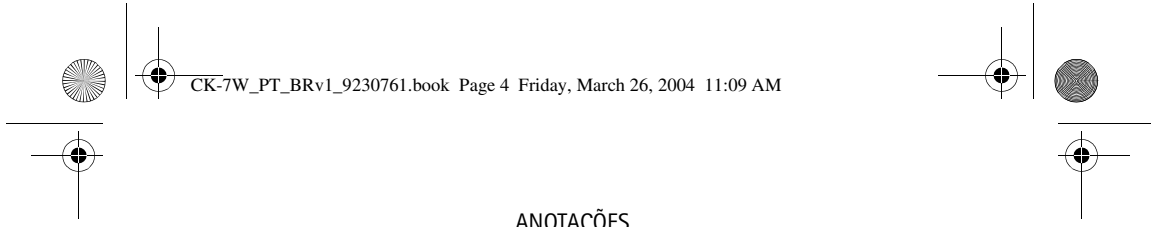



Conteúdo

Para sua proteção	1
Introdução	2
O Kit Veicular Nokia CK-7W	2
Tecnologia Bluetooth	3
Senha Bluetooth	3
1 Antes de iniciar	4
Resumo	4
Uso de acessórios	5
2 Instalação	6
Informações sobre segurança	6
Configuração	8
Instalar o Kit Veicular CK-7W	10
Testes	13
3 Operação do Kit Veicular CK-7W	14
Conectar um telefone celular utilizando a tecnologia sem fios Bluetooth	14
Conectar um telefone celular utilizando um cabo de dados	15
4 Operação	16
Botão de controle remoto	16
Ligar/Desligar o Kit Veicular CK-7W	17
Operação do Kit Veicular CK-7W	17
Cuidado e manutenção	19

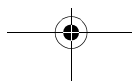
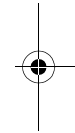
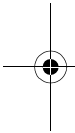

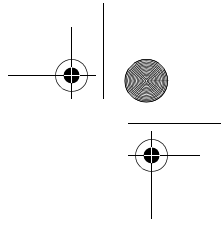
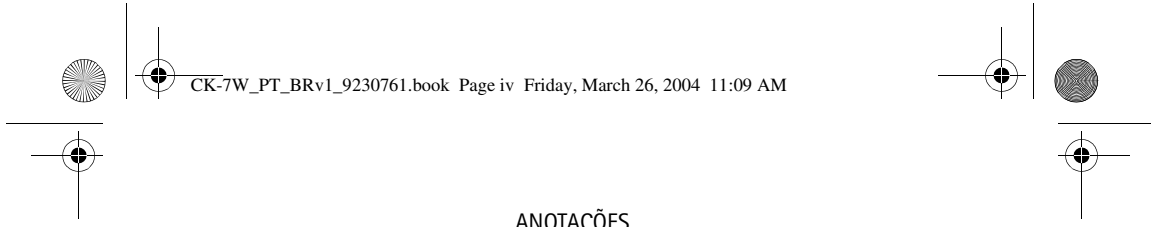

ANOTAÇÕES

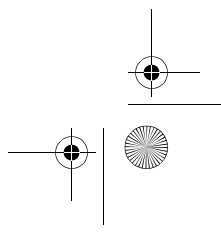
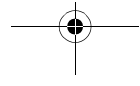
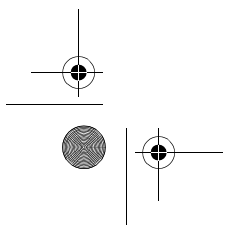
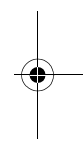
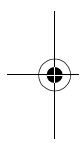

Para sua proteção

Leia estas simples diretrizes. A falta de atenção a estas regras poderá causar perigo ou ser ilegal. Este manual contém informações detalhadas.

Mantenha todos os cartões SIM e acessórios fora do alcance de criança.



SEGURANÇA AO VOLANTE EM PRIMEIRO LUGAR

Lembre-se de que a segurança ao volante de um veículo exige a concentração total de todos os motoristas. Utilize o Kit Veicular CK-7W somente se as condições de tráfego permitirem que o uso seja seguro, e confira se as leis e regulamentos locais proibem o uso de telefones celulares enquanto estiver dirigindo.



INTERFERÊNCIA

Telefones sem fios estão sujeitos a interferências que podem afetar sua operação.



SERVIÇO AUTORIZADO

Somente técnicos autorizados deverão instalar ou consertar equipamentos celulares.



CONEXÃO COM OUTROS DISPOSITIVOS

Ao conectar com qualquer dispositivo utilizando a tecnologia Bluetooth sem fios, leia o manual do mesmo para obter instruções detalhadas sobre segurança. Não conecte produtos não compatíveis.



SUBSTITUIR FUSÍVEL

Substitua o fusível queimado com um do mesmo tipo e tamanho. Nunca use um fusível mais forte!

Introdução

- O KIT VEICULAR NOKIA CK-7W

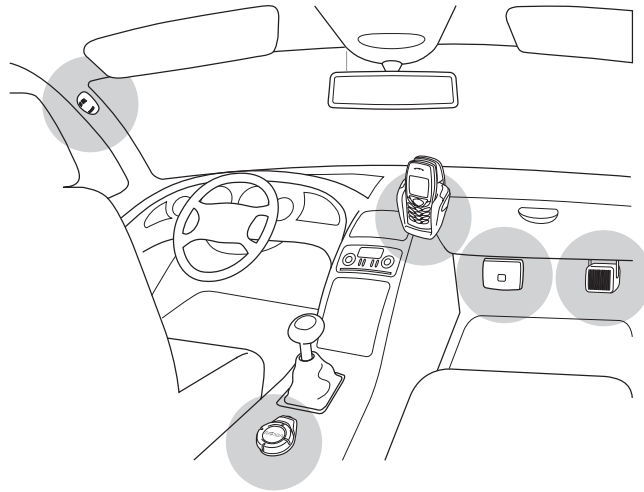

Instalação do Kit Veicular CK-7W no console

O Kit Veicular Nokia CK-7W foi projetado para instalação em veículos com a finalidade de permitir a operação viva-voz de telefones celulares e a utilização de funções específicas ao telefone.

Deu-se ainda atenção especial a um processo de instalação fácil e agilizado. Um telefone celular pode ser conectado ao Kit Veicular de duas maneiras: utilizando um suporte opcional com cabo, ou por meio de uma conexão Bluetooth sem fios.

Em alguns países, o uso do Kit Veicular poderá ser limitado por lei. Siga todas as leis e regulamentos aplicáveis.



• TECNOLOGIA BLUETOOTH

A tecnologia Bluetooth é um padrão internacional para comunicações sem fios a curta distância. Ela permite estabelecer uma conexão sem fios num raio de 10 m entre o Kit Veicular e um dispositivo compatível.

O Kit Veicular foi projetado para uso com qualquer telefone celular que suporte um Perfil Viva-voz Bluetooth (especificação Bluetooth 1.1).

A conexão sem fios entre dispositivos compatíveis, estabelecida via tecnologia Bluetooth, é gratuita para o usuário. Em alguns países, podem existir restrições relacionadas ao uso de dispositivos Bluetooth. Verifique com as autoridades locais.

• SENHA BLUETOOTH

Quando estabelecer a conexão sem fios com um dispositivo compatível pela primeira vez, utilizando a tecnologia Bluetooth, você necessitará de uma senha para fazer o pareamento dos dispositivos.

A senha é um código numérico de quatro dígitos que corresponde aos últimos quatro dígitos do número de série fornecido com o Kit Veicular.

O número de série encontra-se na etiqueta da unidade viva-voz, e no adesivo que acompanha este manual do usuário.

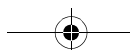
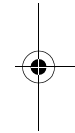
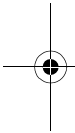

1 Antes de iniciar

- RESUMO

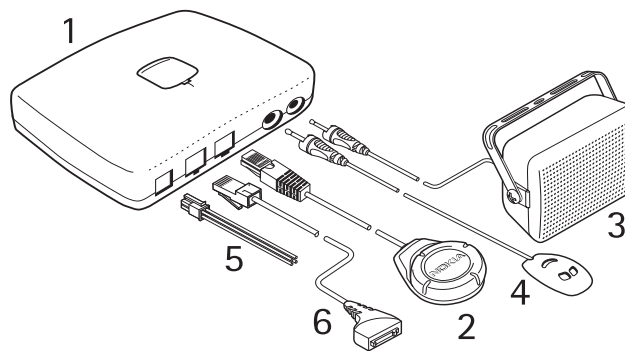

O Kit Veicular CK-7W inclui os componentes ilustrados.

- 1 Unidade viva-voz HF-5 com placa de montagem MK-2
- 2 Botão de controle remoto CU-7
- 3 Alto-falante HFS-12
- 4 Microfone HFM-8
- 5 Cabo elétrico PCU-4
- 6 Cabo de dados CA-27



Antes de iniciar

• USO DE ACESSÓRIOS

Dependendo da configuração, uma variedade de acessórios opcionais foi disponibilizada para este Kit Veicular. Antes de iniciar a instalação, solicite a opinião de um profissional sobre os acessórios que melhor se adaptam às suas exigências. Utilize apenas acessórios originais Nokia. Certifique-se de que apenas produtos compatíveis sejam conectados ao Kit Veicular.

Suporte de telefone

Um suporte de telefone pode ser adquirido como parte do kit veicular, ou como acessório separado.

Se você pretende conectar o telefone diretamente a uma unidade viva-voz que utilize um cabo de dados, será necessário obter um suporte projetado para uso com telefones compatíveis.

Acoplador de antena

Um acoplador de antena pode ser adquirido como parte do kit veicular, ou como acessório separado.

O acoplador será necessário para conectar uma antena externa. Vários acopladores estão disponíveis no mercado para telefones celulares e para suportes de telefone. Um acoplador de antena melhora a recepção do telefone quando em uso no carro.

Antena GSM

Uma antena GSM compatível permite otimizar conexões sem fios.

A antena GSM pode ser adquirida de um revendedor Nokia autorizado.

Se você instalou uma antena externa, lembre-se de que, a fim de cumprir com os parâmetros de exposição RF para dispositivos móveis, uma distância mínima de 20 cm deve ser mantida entre a antena e as pessoas nas imediações.

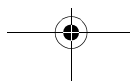
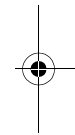
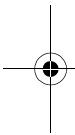



2 Instalação

• INFORMAÇÕES SOBRE SEGURANÇA

As regras básicas delineadas a seguir deverão ser seguidas quando o Kit Veicular CK-7W estiver sendo instalado.

Atenção:

- Somente técnicos qualificados deverão consertar ou instalar o Kit Veicular CK-7W num automóvel, utilizando os componentes originais Nokia, inclusos na embalagem de vendas. Instalações ou consertos mal feitos poderão ser perigosos e poderão invalidar qualquer garantia aplicável ao dispositivo. Os usuários finais do Kit Veicular CK-7W devem considerar que este kit contém equipamento técnico complexo, que exige instalação profissional, bem como o uso de ferramentas especializadas e conhecimento técnico.
- Observe que as instruções contidas neste guia de instalação oferecem normas generalizadas de procedimento para a instalação do Kit Veicular CK-7W num automóvel. Entretanto, devido à grande variedade de tipos e modelos de carro disponíveis no mercado, este guia não pode levar em consideração as exigências técnicas particulares, relevantes em cada veículo. Consulte o fabricante do veículo para obter informações mais detalhadas sobre o modelo em particular.
- Assegure-se de que a ignição do carro está desligada, e desconecte a bateria do mesmo antes de iniciar o processo de instalação, assegurando-se também de que ela não poderá ser acidentalmente reconectada.
- Lembre-se que os sistemas modernos de automóveis incluem computadores, os quais armazenam os parâmetros principais do veículo. Se a bateria do carro for desconectada impropriamente, isso poderá causar a perda de dados, resultando em dificuldades na reinicialização do sistema. Se houver qualquer dúvida, consulte o revendedor do carro antes de fazer a instalação.
- Não conecte o Kit Veicular CK-7W aos cabos de alta-tensão do sistema de ignição.

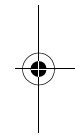
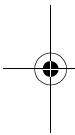



Instalação

- Todo o equipamento deve ser montado de modo que não interfira com a operação do veículo.
- O técnico especializado poderá oferecer informações sobre outros meios adequados para montagem do equipamento no carro, sem fazer perfurações.
- O suporte de telefone deverá ser afixado no painel de instrumentos, ou em qualquer outro lugar em que o aparelho esteja claramente visível ao usuário, sem impedir o controle ou operação do veículo. O teclado deverá estar ao alcance do usuário.
- Quando o Kit Veicular CK-7W estiver sendo instalado, assegure-se de que a sua instalação não interferirá com o controle e a operação normal dos freios e volante, nem com outros sistemas essenciais para a operação adequada do carro. Confira se a inflação do air bag não será bloqueada ou prejudicada de nenhuma forma.
- Não fume enquanto estiver consertando o carro. Certifique-se de que não há fogo ou faísca por perto.
- Tome cuidado para não danificar cabos elétricos, linhas hidráulicas ou de combustíveis, nem o equipamento de segurança durante a instalação.
- Sinais de rádio (RF) podem afetar sistemas eletrônicos em veículos, caso esses não tenham sido adequadamente instalados ou isolados (por exemplo, sistemas de injeção de combustível, de freios antiderrapantes, sistemas de controle de velocidade, air bags, etc.). Se você perceber um defeito ou alteração na operação de um desses sistemas, contate o revendedor do carro.
- Assegure-se ainda de que os cabos sejam instalados de modo a evitar pressão física ou mecânica desnecessária (como por exemplo, embaixo de assentos ou em contato com superfícies salientes).

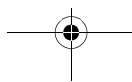
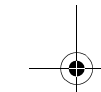
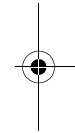
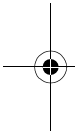

• CONFIGURAÇÃO

O Kit Veicular CK-7W oferece duas configurações básicas diferentes para sua instalação:

Conectar um telefone celular utilizando a tecnologia sem fios Bluetooth

Faça o pareamento dos dois dispositivos antes de estabelecer a conexão entre o telefone celular compatível e a unidade viva-voz.

Um telefone celular compatível, que suporte a tecnologia Bluetooth, será necessário para essa configuração.

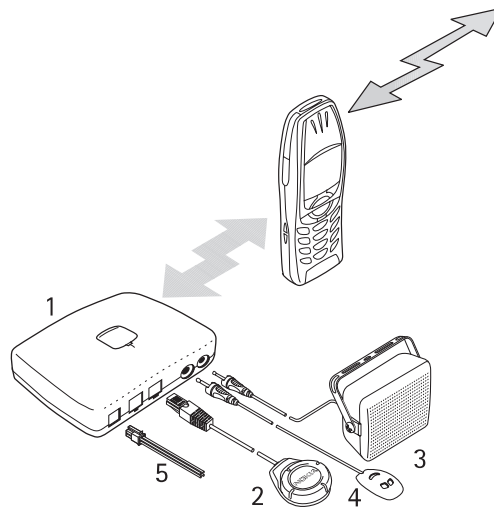

Instalação

Conectar um telefone celular utilizando um cabo de dados e um suporte de telefone

Se a conexão for estabelecida por meio de um cabo de dados, o telefone compatível estará pronto para operar com o Kit Veicular CK-7W no momento em que for colocado no suporte.

Dependendo do telefone celular e dos acessórios instalados no veículo, tais como um suporte de telefone, um acoplador de antena ou uma antena externa poderão ser necessários.

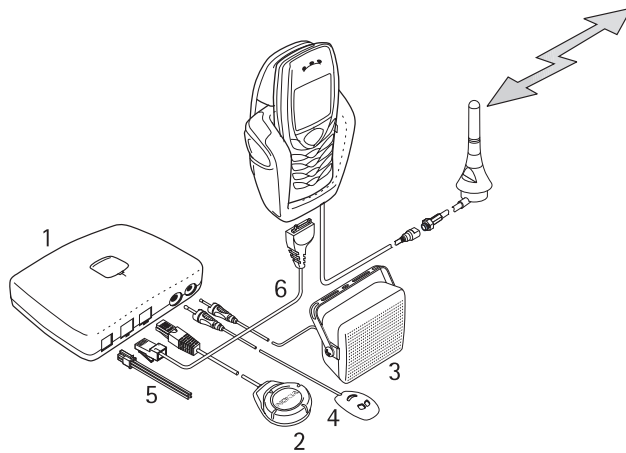

• INSTALAR O KIT VEICULAR CK-7W

Veja um exemplo de instalação adequada do equipamento do Kit Veicular na seção Introdução, pág. 2.

Unidade viva-voz

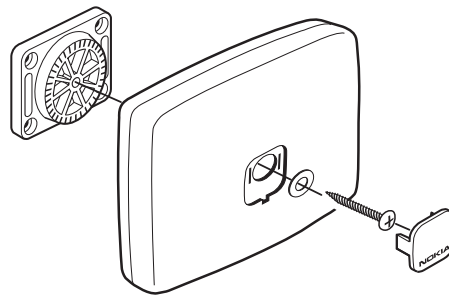

Quando instalar a unidade viva-voz, assegure-se de que os cabos do microfone e alto-falantes alcançam o lugar onde deseja montá-los. Não instale a unidade viva-voz num lugar fechado, de metal, ou num lugar em que estaria protegida das ondas de rádio, pois isso impediria o uso da função Bluetooth.

Para instalar a unidade, afixe primeiro a placa de montagem fornecida com o Kit Veicular e então prenda a unidade viva-voz com o parafuso que atravessa a unidade inteira. Para concluir, coloque a tampa com o logo Nokia no lugar certo, e pressione para encaixá-la.

Botão de controle remoto

O botão de controle remoto deve ser posicionado de modo que esteja ao alcance do usuário. Entretanto, assegure-se de que seja posicionado de modo a facilitar a conexão do cabo da unidade viva-voz. Um lugar adequado para o posicionamento do botão de controle remoto seria o console, entre os dois assentos da frente.

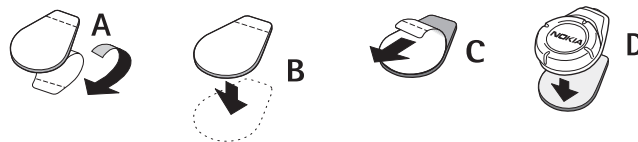



Instalação

Para montar o botão de controle remoto, utilize a fita Velcro fornecida. Em primeiro lugar, separe as duas partes do botão de controle remoto. Para fixar o controle remoto no carro: remova o papel que protege o adesivo (A) de uma parte da fita Velcro, e fixe-a no lugar do carro em que deseja instalar o controle remoto (B). Assegure-se de que a superfície onde pretende colocá-lo está bem limpa e seca.

Em seguida, fixe a outra parte da fita Velcro: remova o papel que protege o adesivo (C) e fixe a fita embaixo do botão de controle remoto.

Pressione o botão (D) firmemente na fita Velcro fixada no carro.

Alto-falante

Para assegurar qualidade acústica, monte o alto-falante de modo que fique de frente para o usuário. Recomendamos que o alto-falante seja montado a uma distância mínima de 1m do microfone a fim de evitar interferências.

O Kit Veicular também suporta conexões com sistemas compatíveis de som do carro. Se quiser utilizar o rádio instalado no veículo com o Kit Veicular como saída de áudio, solicite recomendações de um técnico especializado.

Conecte o alto-falante ou sistema de som compatível à saída denominada "SPEAKER".

Microfone

A seleção cuidadosa de uma posição de montagem para o microfone pode aumentar a qualidade da transmissão de voz.

Instale o microfone a aproximadamente 30 cm de distância da cabeça do usuário, e posicione-o de modo que esteja apontando para a boca do usuário. As posições com melhores resultados são, em geral, perto do espelho retrovisor ou da viseira do carro. Recomenda-se que o microfone seja mantido a uma distância mínima de 1m do alto-falante do Kit Veicular, para evitar interferências.

Monte o microfone cuidadosamente para evitar sua exposição ao vento produzido pelas janelinhas de ventilação. Não coloque o cabo do microfone em cima dos sistemas de ar condicionado, ventilação ou aquecimento.

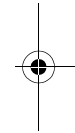
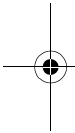



Utilize o adesivo dupla-face fornecido para fixar o microfone, pois assim evitará a transmissão de ruídos da carroceria do carro para o interior do mesmo.

Insira o conector no plugue denominado "MIC", na unidade viva-voz, e gire-o no sentido horário para prendê-lo bem.



Nota: O uso de qualquer outro microfone, que não o fornecido com o Kit Veicular CK-7W, poderá afetar a qualidade da transmissão.

Cabo elétrico

Os condutores que formam o cabo elétrico devem ser conectados segundo o diagrama.

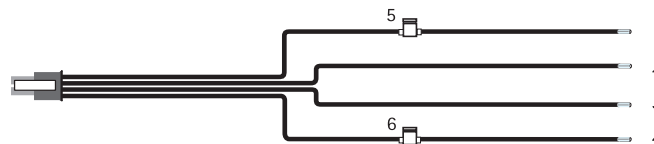

- Conecte o condutor preto ao ponto terra do veículo (GND).
- Conecte o condutor amarelo ao conector MUTE do som do carro.

Se o rádio não possuir um conector MUTE, esse condutor permanece desligado. Nesse caso, o rádio não será silenciado automaticamente durante uma chamada.

Um relé adicional pode ser utilizado para permitir que o rádio seja silenciado. Quando você recebe uma chamada, o Kit Veicular troca a função do condutor amarelo (MUTE) para terra, silenciando o rádio. Quando a chamada finaliza, o condutor amarelo separa-se do terra, e o som do rádio volta a tocar.

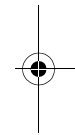
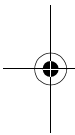



Instalação



- Conecte o condutor azul ao plugue IGNS do carro, utilizando o fusível 1A incluso.

Alguns veículos não possuem uma conexão IGNS. Esse condutor não é necessário para a operação do Kit Veicular; o condutor azul pode permanecer desligado. Entretanto, se esse for o caso, o Kit Veicular não desligará automaticamente quando se desligar a ignição. Para evitar o descarregamento acidental da bateria, o Kit Veicular desliga automaticamente após dois minutos, a não ser que um telefone celular esteja conectado, por meio de tecnologia Bluetooth ou por cabo de dados.

- Conecte o condutor vermelho ao pólo positivo da bateria de 12V do carro, utilizando o fusível 2A, incluso.

O plugue de quatro-pinos do cabo elétrico conecta-se à porta "DC" da unidade viva-voz.

Cabo de dados

O cabo de dados conecta a unidade viva-voz ao telefone compatível, isto é, por meio do suporte de telefone.

Conecte uma ponta do cabo na tomada "PHONE" da unidade viva-voz, e a outra ponta no suporte de telefone.

Se o Kit Veicular for utilizado com tecnologia Bluetooth, não será necessário conectar o cabo de dados.

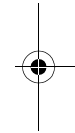
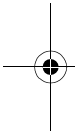

• TESTES

Após instalar o Kit Veicular, será necessário verificar se ele está funcionando corretamente. Ao testar a operação do equipamento, verifique também se ele foi montado de modo a não interferir com o motorista durante a operação do veículo.



3 Operação do Kit Veicular CK-7W

Um telefone celular compatível pode ser conectado ao Kit Veicular CK-7W de duas maneiras: por conexão Bluetooth sem fios, ou pela utilização de um suporte de telefone e um cabo.

• CONECTAR UM TELEFONE CELULAR UTILIZANDO A TECNOLOGIA SEM FIOS BLUETOOTH

Quando você estabelecer uma conexão sem fios através do Kit Veicular, utilizando a tecnologia Bluetooth, será necessário fazer o pareamento da unidade viva-voz com o telefone celular compatível em uso. Só será necessário fazer isso uma vez: daí em diante, os dispositivos serão capazes de se reconhecer e estabelecer a conexão automaticamente.



Nota: Se você deseja estabelecer uma conexão por tecnologia sem fios Bluetooth, não coloque o aparelho celular no suporte de telefone.

Usar a senha Bluetooth para o pareamento

- 1 Confira se o aparelho celular está ligado e a bateria carregada.
- 2 Ligue o Kit Veicular. Para mais informações, veja Ligar/Desligar o Kit Veicular CK-7W, pág. 17.
- 3 Abra o menu Bluetooth no telefone e ative a função.
- 4 Faça as configurações necessárias no telefone para ativar a procura de dispositivos Bluetooth na área de alcance. Para mais informações sobre as configurações exigidas, consulte o manual do usuário apropriado.
- 5 Selecione Advanced Car Kit na lista de dispositivos Bluetooth encontrados.
- 6 Quando solicitado, digite a senha Bluetooth. A senha encontra-se no adesivo, na frente do manual do usuário.

A senha é um código numérico de quatro dígitos que corresponde aos últimos quatro dígitos do número de série fornecido com o Kit Veicular. O número de série poderá ser encontrado na etiqueta da unidade viva-voz.



Operação do Kit Veicular CK-7W

- 7 O aparelho está agora pareado com o Kit Veicular, pronto para ser utilizado.



Nota: O Kit Veicular só pode estabelecer uma conexão sem fios Bluetooth com um telefone celular de cada vez. Por isso, é provável que seja necessário encerrar a conexão Bluetooth ativa, antes de conectar-se a um telefone diferente.

Pareamento automático com um telefone compatível

- 1 Faça as configurações apropriadas no telefone, de modo que o pareamento com o Kit Veicular seja feito sem exigir aceitação ou autorização separadas. Este kit veicular pode ser pareado com 8 telefones celulares compatíveis. As configurações para cada um dos aparelhos será armazenada na memória do kit veicular, para referência futura. Para mais informações sobre as configurações exigidas, consulte o manual do usuário apropriado.
- 2 Ligue o Kit Veicular.
- 3 O Kit Veicular inicia uma busca automática de 30 segundos, procurando até sete configurações de telefones diferentes, pareadas e salvas na memória. Por padrão, o Kit Veicular faz o pareamento com o telefone celular utilizado por último. A procura do Bluetooth ativo é indicada pela luz intermitente no botão de controle remoto.

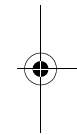
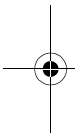

• CONECTAR UM TELEFONE CELULAR UTILIZANDO UM CABO DE DADOS

Se você estiver utilizando essa forma de conexão, o telefone celular estará pronto para uso com o Kit Veicular no momento em que for colocado no suporte de telefone; não será necessário fazer o pareamento dos dispositivos.

Se um telefone celular for colocado num suporte de telefones que esteja conectado ao Kit Veicular por meio de um cabo de dados, o telefone estará ativado, e você não poderá estabelecer uma conexão com outros dispositivos via Bluetooth. Se houver uma conexão Bluetooth ativa no momento em que o telefone celular for colocado num suporte conectado ao Kit Veicular CK-7W, a conexão Bluetooth será automaticamente encerrada.



4 Operação

O Kit Veicular CK-7W pode ser operado por meio do botão de controle remoto, ou pelo teclado de um telefone celular compatível.

• BOTÃO DE CONTROLE REMOTO

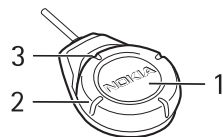

1 O botão pode ser utilizado da seguinte maneira:

- Pressionar
- Pressionar e segurar (aprox. 1 segundo)
- Pressionar rapidamente duas vezes
- Pressionar e segurar por algum tempo (mais de 10 segundos)

2 O anel pode ser utilizado da seguinte maneira:

- Girar para a esquerda
- Girar para a direita

3 O indicador luminoso possui três modos:

- Aceso
- Intermitente
- Apagado

Operação

• LIGAR/DESLIGAR O KIT VEICULAR CK-7W

Se o cabo sensor de ignição estiver conectado, o Kit Veicular liga automaticamente quando a ignição do carro for ligada. O indicador luminoso acende para indicar que o Kit Veicular foi ativado. Quando a ignição do carro for desligada, o Kit Veicular desativa e o indicador luminoso apaga. Para verificar se o Sensor de Ignição (IGNS) funciona com o seu carro e telefone, consulte o manual do usuário sobre compatibilidade.

Se o cabo sensor de ignição (IGNS) não foi conectado durante a instalação do Kit Veicular, e você deseja ligar o Kit Veicular, pressione o botão ligeiramente ou coloque um telefone celular compatível no suporte de telefones, se instalado.



Nota: Se o Kit Veicular foi instalado sem o cabo do Sensor de Ignição (IGNS), quando você o ligar, ele permanecerá ativo enquanto o telefone celular compatível for deixado no suporte.

Se não houver uma conexão com um telefone celular no momento, o Kit Veicular desligará após 2 minutos.

• OPERAÇÃO DO KIT VEICULAR CK-7W

Você pode utilizar o botão de controle remoto para acessar as seguintes funções do telefone:

Atender uma chamada

Para atender, pressione o botão.

Encerrar uma chamada

Para encerrar a chamada ativa, pressione o botão.

Recusar uma chamada

Se não quiser atender a chamada, pressione e segure o botão.

Fazer uma chamada

Selecione o contato desejado na agenda do telefone celular, ou digite o número desejado no teclado do telefone.



Rediscar

Para rediscar um número recentemente chamado, pressione o botão ligeiramente, duas vezes.

Discagem por voz

Você pode utilizar marcas vocais salvas no telefone:

- 1 Para iniciar a discagem por voz, pressione e segure o botão até escutar um som.
- 2 Pronuncie a marca vocal.
- 3 O aparelho executa a marca vocal e disca o número de telefone associado.

Para detalhes sobre a utilização de discagem por voz, consulte o manual do usuário do seu telefone.



Nota: Alguns telefones podem não dar suporte a todas as funções descritas neste guia.

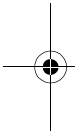

Ajustar o volume

Para ajustar o volume do alto-falante, gire o anel.

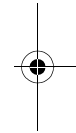

Procura manual de dispositivos Bluetooth

Se você ainda não estabeleceu uma conexão com um telefone celular, inicie procurando manualmente por um telefone que suporte Bluetooth.

Para ativar a função de procura Bluetooth no Kit Veicular, pressione e segure o botão.

Se a procura de dispositivos Bluetooth estiver ativada, o indicador luminoso fica intermitente.

Reconfiguração de dispositivos Bluetooth pareados

O Kit Veicular salva o último dispositivo Bluetooth com o qual foi pareado.

A lista de dispositivos Bluetooth pareados pode ser excluída. Para apagar a lista, o Kit Veicular deve estar desligado (o indicador luminoso apaga):

Pressione e segure o botão até ouvir um sinal de aviso indicando que a lista foi excluída.





Operação

Alternar entre o modo viva-voz e o telefone

- Se você conectou um telefone celular compatível ao Kit Veicular utilizando um cabo de dados, remova o telefone do suporte para alternar entre os modos de operação viva-voz e telefone.
- Para voltar ao modo viva-voz, recoloque o aparelho no suporte. O telefone pode agora ser utilizado em modo viva-voz por meio do Kit Veicular.
- Se você conectou um telefone celular compatível ao Kit Veicular utilizando Bluetooth, você poderá alternar a chamada ativa entre o Kit Veicular e o telefone, ou vice-versa. Pressione e segure o botão ou utilize a função correspondente no telefone celular.

Cuidado e manutenção

Este Kit Veicular CK-7W é um produto de planejamento e fabricação de alta tecnologia e deve ser tratado com cuidado. As sugestões abaixo deverão ser atendidas para validação da garantia do seu aparelho e para o prolongamento de sua vida útil.

- Mantenha todos os acessórios fora do alcance de crianças.
- Mantenha o Kit Veicular seco. A chuva, a umidade e líquidos em geral contêm minerais que corroem circuitos eletrônicos.
- Não use ou guarde o Kit Veicular em lugares empoeirados ou sujos, pois as partes móveis poderão ser danificadas.
- Não tente abrir o Kit Veicular. O manuseio não especializado poderá causar danos.
- Não use produtos químicos corrosivos, solventes ou detergentes fortes para limpar o Kit Veicular ou o botão de controle remoto.
- Não pinte o Kit Veicular ou o botão de controle remoto. As tintas podem obstruir as partes móveis deste aparelho e impedir sua operação adequada.

Se o Kit Veicular ou o botão de controle remoto não estiverem funcionando corretamente, leve-os a uma assistência técnica autorizada Nokia ou consulte a Central de Atendimento Nokia.

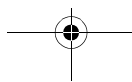
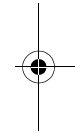
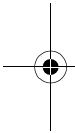

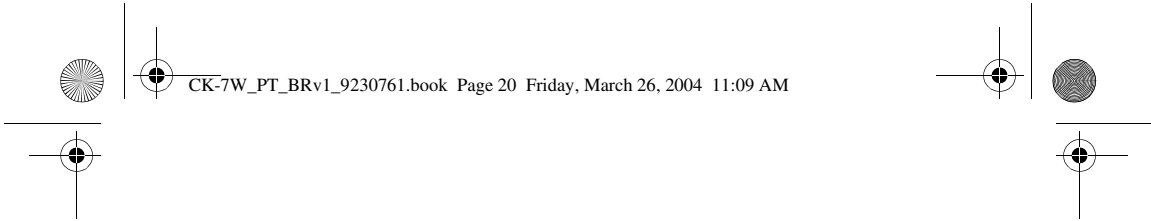

Para saber o endereço e o telefone da assistência técnica autorizada mais próxima, consulte o site www.nokia.com.br ou ligue para a Central de Atendimento Nokia: (0xx11) 5681-3333.

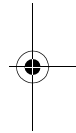
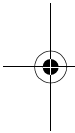

NOKIA
CONNECTING PEOPLE

© Nokia 2004. Todos os direitos reservados.

Os logos Nokia, Connecting People e Original Enhancements são marcas comerciais e/ou marcas registradas da Nokia Corporation e/ou companhias afiliadas.

Version 1 Impresso na Alemanha 03/04 9230761



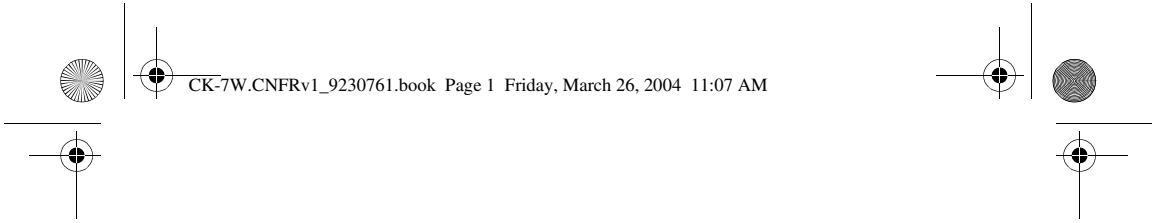

Ensemble évolué pour voiture CK-7W Guide d'utilisation

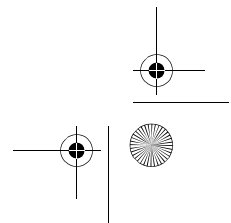
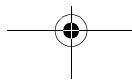
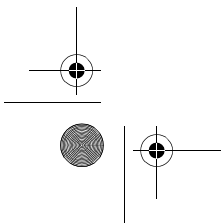
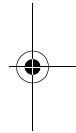
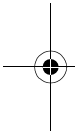



DÉCLARATION DE CONFORMITÉ

NOKIA CORPORATION déclare, en vertu de sa seule autorité, que l'ensemble évolué pour voiture CK-7W est conforme aux dispositions suivantes de la Directive du Conseil : 1999/5/EC. La déclaration de conformité peut être consultée à l'adresse suivante :
http://www.nokia.com/phones/declaration_of_conformity/.

CE 168

Copyright © 2004 Nokia. Tous droits réservés.

La reproduction, le transfert, la distribution ou le stockage d'une partie ou de la totalité du contenu du présent document, sous quelque forme que ce soit, sans l'autorisation écrite préalable de Nokia est interdite.

Nokia et Nokia Connecting People sont des marques de commerce ou des marques déposées de Nokia Corporation. Les autres noms de produit et de société mentionnés dans le présent document peuvent être des marques déposées ou des noms commerciaux de leurs propriétaires respectifs.

Bluetooth est une marque déposée de Bluetooth SIG, Inc.

Nokia applique une méthode de développement continu. Nokia se réserve le droit de modifier et d'améliorer tout produit décrit dans le présent document sans préavis.

NOKIA NE SAURAIT EN AUCUN CAS ÊTRE TENUE RESPONSABLE DE TOUTE PERTE DE DONNÉES OU DE REVENUS AINSI QUE DE TOUT DOMMAGE SPÉCIAL, ACCESSOIRE OU INDIRECT, QUELLE QU'EN SOIT LA CAUSE.

Le contenu du présent document est proposé «tel quel». Sous réserve des lois applicables, aucune garantie sous quelque forme que ce soit, explicite ou implicite, y compris, mais sans s'y limiter, les garanties implicites de valeur marchande et d'adéquation à un usage particulier, n'est accordée quant à l'exactitude, à la fiabilité ou au contenu du présent document. Nokia se réserve le droit de modifier le présent document ou de l'annuler sans préavis.

La disponibilité de certains produits et services peut varier selon la région. Veuillez vous renseigner auprès du détaillant Nokia le plus proche.

CONTRÔLE DES EXPORTATIONS

Ce produit contient des composants, de la technologie et des logiciels exportés des États-Unis conformément aux règlements sur l'exportation. Vous convenez de ne pas exporter ce produit en contravention des lois du Canada ou des États-Unis sur l'exportation.

AVIS DE LA FCC OU D'INDUSTRIE CANADA

Cet appareil est conforme aux dispositions de la partie 15 du règlement de la FCC. Son utilisation est assujéti aux deux conditions suivantes : (1) l'appareil ne doit pas causer d'interférence nuisible et (2) l'appareil doit accepter toute interférence à la réception, y compris une interférence susceptible de gêner son fonctionnement.

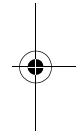
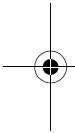
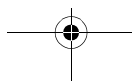
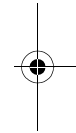
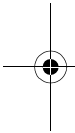
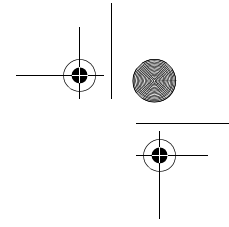
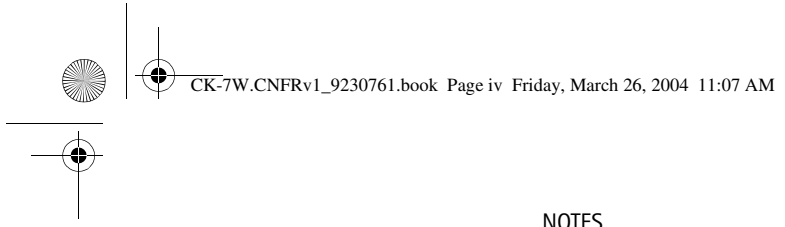



Table des matières

Pour votre sécurité	1
Introduction	2
Votre ensemble évolué pour voiture Nokia CK-7W.	2
Technologie sans fil Bluetooth	3
Code d'authentification Bluetooth	3
1 Avant de commencer	4
Présentation	4
Utilisation des accessoires	5
2 Installation	6
Information sur la sécurité	6
Configuration	8
Installation de l'ensemble évolué pour voiture CK-7W	10
Essai de fonctionnement	13
3 Mise en service de l'ensemble évolué pour voiture CK-7W	14
Connexion d'un téléphone mobile au moyen de la technologie sans fil Bluetooth	14
Connexion d'un téléphone mobile au moyen du câble de données	16
4 Fonctionnement	17
Bouton de télécommande	17
Mise en fonction/hors fonction de l'ensemble évolué pour voiture CK-7W	18
Utilisation de l'ensemble évolué pour voiture CK-7W	18
Précautions d'utilisation et maintenance	21
Nokia – Garantie limitée de 1 an	22





NOTES

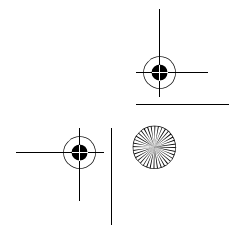
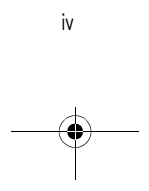
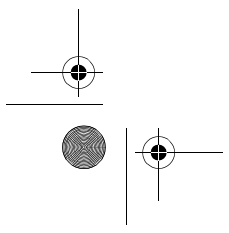
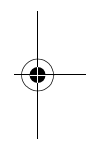
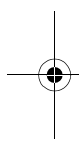



Pour votre sécurité

Veillez lire ces consignes simples. Il peut s'avérer dangereux, voire illégal, de ne pas s'y conformer. De plus amples renseignements sont donnés dans le présent guide.

Gardez toujours les cartes SIM et les accessoires miniatures hors de portée des jeunes enfants.



LA SÉCURITÉ ROUTIÈRE AVANT TOUT

Gardez à l'esprit que la conduite sécuritaire d'un véhicule automobile exige toute l'attention du conducteur. N'utilisez votre ensemble évolué pour voiture CK-7W que si les conditions de la circulation s'y prêtent et que les règlements locaux permettent l'utilisation de téléphones mobiles au volant.



INTERFÉRENCE

Tous les téléphones sans fil sont sensibles aux interférences qui peuvent nuire à leur fonctionnement.



TECHNICIENS QUALIFIÉS

L'installation ou la réparation de votre équipement doit être confiée uniquement à des professionnels qualifiés.



CONNEXION À D'AUTRES APPAREILS

Lorsque vous connectez votre appareil à un autre appareil qui utilise la technologie sans fil Bluetooth, consultez le guide d'utilisation approprié pour connaître les consignes de sécurité détaillées. Ne connectez jamais d'appareils incompatibles.



REPLACEMENT DES FUSIBLES

Remplacer un fusible grillé par un fusible de même type et de même calibre. N'utilisez jamais un fusible de calibre supérieur!

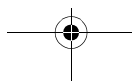
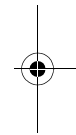
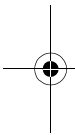

Introduction

- **VOTRE ENSEMBLE ÉVOLUÉ POUR VOITURE NOKIA CK-7W**

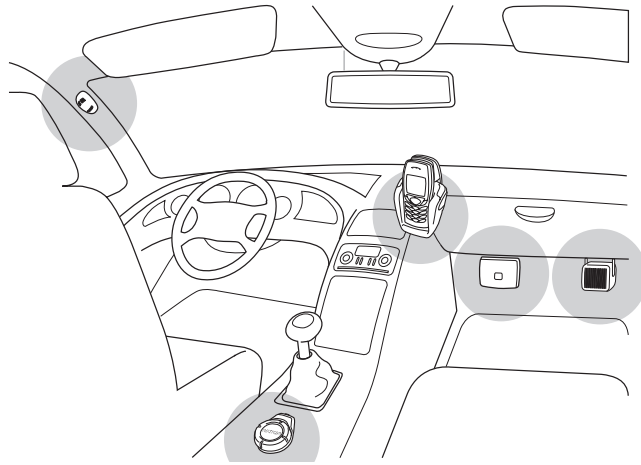

Installation de l'ensemble évolué pour voiture CK-7W dans la console.

L'ensemble évolué pour voiture Nokia CK-7W est spécialement conçu pour être installé dans les véhicules automobiles afin de permettre l'utilisation mains libres des téléphones mobiles et de leurs diverses fonctions.

Une attention particulière a été portée à la facilité et à la rapidité d'installation. L'ensemble évolué pour voiture permet de connecter un téléphone mobile de deux façons : à l'aide d'un support de téléphone optionnel et d'un câble ou par connexion sans fil Bluetooth.

Les lois en vigueur dans certains pays peuvent restreindre l'utilisation de l'ensemble évolué pour voiture. Veuillez observer les lois et les règlements applicables.



• TECHNOLOGIE SANS FIL BLUETOOTH

La technologie Bluetooth est une norme internationale en matière de communication sans fil de courte portée. Elle permet d'établir une connexion sans fil entre l'ensemble évolué pour voiture et un appareil compatible dans un rayon de 10 m (32,8 pi).

L'ensemble évolué pour voiture peut être utilisé avec tout téléphone mobile qui supporte le profil mains libres Bluetooth (norme Bluetooth 1.1).

La connexion sans fil établie entre des appareils compatibles à l'aide de la technologie Bluetooth n'entraîne pas de frais pour l'utilisateur. Il est à noter que certains pays imposent des restrictions à l'utilisation des appareils Bluetooth. Renseignez-vous auprès des autorités locales.

• CODE D'AUTHENTIFICATION BLUETOOTH

Lors de la mise en liaison initiale d'appareils compatibles à l'aide de la technologie sans fil Bluetooth, vous devez entrer un code d'authentification pour coupler les appareils.

Le code d'authentification se compose des quatre derniers chiffres du numéro de série de l'ensemble évolué pour voiture.

Ce numéro de série se trouve sur le monogramme fixé à l'unité mains libres et sur l'autocollant joint au présent guide d'utilisation.

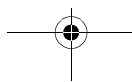
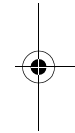
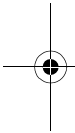

1 Avant de commencer

• PRÉSENTATION

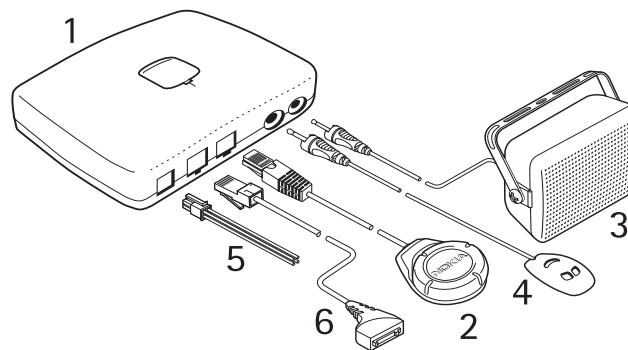

L'ensemble évolué pour voiture CK-7W comprend les éléments illustrés ci-dessus.

- 1 Unité mains libres HF-5 avec plaque de montage MK-2
- 2 Bouton de télécommande CU-7
- 3 Haut-parleur HFS-12
- 4 Microphone HFM-8
- 5 Ensemble de câbles PCU-4
- 6 Câble de données CA-27



Avant de commencer

• UTILISATION DES ACCESSOIRES

Selon la configuration utilisée, divers accessoires optionnels sont disponibles pour compléter votre ensemble évolué pour voiture. Avant toute installation, consultez un spécialiste pour déterminer les accessoires qui répondent le mieux à vos besoins. N'utilisez que des accessoires approuvés. Assurez-vous de la compatibilité des appareils destinés à être connectés à votre ensemble évolué pour voiture.

Support de téléphone

Vous pouvez acheter un support de téléphone avec votre ensemble pour voiture ou séparément, à titre d'accessoire.

Lorsque le téléphone est destiné à être connecté directement à l'unité mains libres au moyen du câble de données, vous devez vous procurer un support conçu pour un téléphone mobile compatible.

Coupleur d'antenne

Vous pouvez acheter un coupleur d'antenne avec votre ensemble pour voiture ou séparément, à titre d'accessoire.

Un coupleur d'antenne est nécessaire pour connecter une antenne externe. Divers coupleurs d'antenne sont disponibles pour les différents téléphones mobiles et supports de téléphone sur le marché. Un coupleur d'antenne améliore la réception du téléphone mobile à bord du véhicule.

Antenne GSM

L'utilisation d'une antenne GSM compatible permet d'optimiser la connexion sans fil.

Vous pouvez vous procurer une antenne GSM auprès d'un détaillant Nokia autorisé.

Si vous avez installé une antenne externe, rappelez-vous que pour satisfaire aux exigences de la FCC en matière d'exposition RF visant les émetteurs mobiles, il faut conserver une distance minimale de 20 cm (7,8 po) entre l'antenne et les passagers.

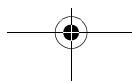
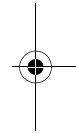
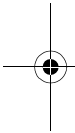



2 Installation

• INFORMATION SUR LA SÉCURITÉ

Les consignes de sécurité élémentaires énoncées ci-dessous doivent être observées lors de l'installation de l'ensemble évolué pour voiture CK-7W.

Attention :

- Seuls des techniciens doivent procéder à la réparation de l'ensemble évolué pour voiture CK-7W ou à son installation dans un véhicule à l'aide des pièces d'origine approuvées par Nokia et fournies dans le carton d'emballage. Une installation ou un entretien mal exécutés risquent d'être dangereux et peuvent invalider les garanties du produit. L'utilisateur doit se rappeler que l'ensemble évolué pour voiture CK-7W comprend des dispositifs complexes dont l'installation doit être confiée à des professionnels possédant les outils et les compétences appropriés.
- À noter que les instructions fournies dans le présent guide d'installation sont des directives générales qui s'appliquent à l'installation de l'ensemble évolué pour voiture CK-7W dans un véhicule automobile. Cependant, en raison de la grande diversité des véhicules disponibles sur le marché, il est impossible de tenir compte des exigences techniques propres à un modèle particulier. Pour plus de détails sur un véhicule particulier, communiquez avec le constructeur ou un concessionnaire.
- Avant de commencer l'installation, assurez-vous que le contact est coupé et déconnectez la batterie du véhicule de manière que la connexion ne peut être rétablie accidentellement.
- Rappelez-vous que les systèmes automobiles modernes comportent des ordinateurs embarqués qui conservent en mémoire certains paramètres essentiels du véhicule. Le fait de déconnecter la batterie du véhicule peut entraîner une perte de données et exiger une intervention coûteuse pour réinitialiser le système. En cas de doute, communiquez avec votre concessionnaire automobile avant d'entreprendre tout travail d'installation.

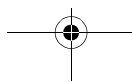
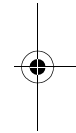
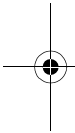



Installation

- Ne pas connecter l'ensemble évolué pour voiture CK-7W aux câbles à haute tension du circuit d'allumage.
- Tout l'équipement doit être monté de manière à ne pas nuire au fonctionnement ou à la conduite du véhicule.
- Votre technicien peut être en mesure de vous proposer des solutions de rechange pour réaliser un montage adéquat dans votre véhicule sans percer de trous.
- Le support de téléphone doit être fixé au tableau de bord ou à tout autre endroit de l'habitacle permettant à l'utilisateur de voir clairement l'écran de l'appareil sans nuire à la conduite ou au fonctionnement du véhicule. Le clavier doit être à la portée de l'utilisateur.
- Assurez-vous que l'installation de l'ensemble évolué pour voiture CK-7W n'a aucune incidence sur les systèmes de direction et de freinage ou tout autre système essentiel au bon fonctionnement du véhicule. Assurez-vous qu'aucun obstacle ne gêne le déploiement du sac gonflable.
- Ne fumez pas pendant l'installation dans le véhicule. Assurez-vous qu'il n'y a aucune flamme ou autre source d'incendie dans les environs.
- Faites attention de ne pas endommager les fils électriques, les canalisations d'essence, les conduites de frein ou les dispositifs de sécurité pendant l'installation.
- Les fréquences radioélectriques peuvent nuire au fonctionnement des dispositifs électroniques automobiles qui sont mal installés ou insuffisamment protégés (par exemple, les systèmes d'injection de carburant, de freins antiblocage, de régulation de vitesse ou de sac gonflable). En cas de panne ou de modification du fonctionnement d'un tel système, communiquez avec votre concessionnaire automobile.
- S'assurer que les câbles sont installés de manière qu'ils ne soient pas soumis à une usure mécanique (par exemple, sous un siège ou contre des arêtes vives).

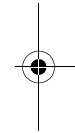
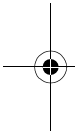

• CONFIGURATION

En principe, l'ensemble évolué pour voiture CK-7W offre deux configurations de base pour l'installation :

Connexion d'un téléphone mobile au moyen de la technologie sans fil Bluetooth

Pour être en mesure d'établir une connexion entre un téléphone mobile compatible et l'unité mains libres, les deux appareils doivent d'abord être couplés.

Cette configuration exige un téléphone mobile compatible qui supporte la technologie sans fil Bluetooth.

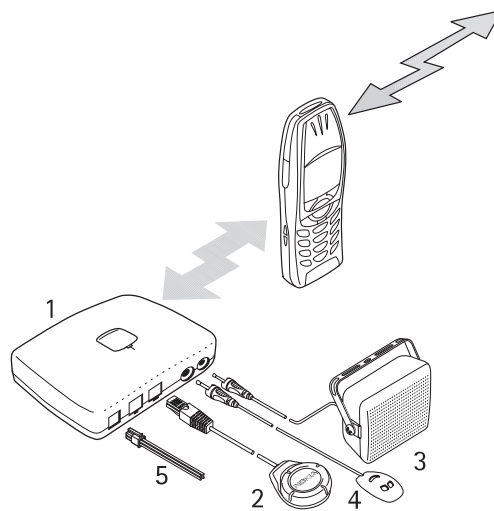

Installation

Connexion d'un téléphone mobile au moyen du câble de données et d'un support de téléphone

Lorsqu'il est raccordé par le câble de données et placé sur le support, le téléphone mobile compatible est prêt à fonctionner avec l'ensemble évolué pour voiture.

Selon le modèle de votre téléphone mobile et l'équipement de votre véhicule, certains accessoires supplémentaires peuvent être requis, comme un support de téléphone, un coupleur d'antenne ou une antenne externe.

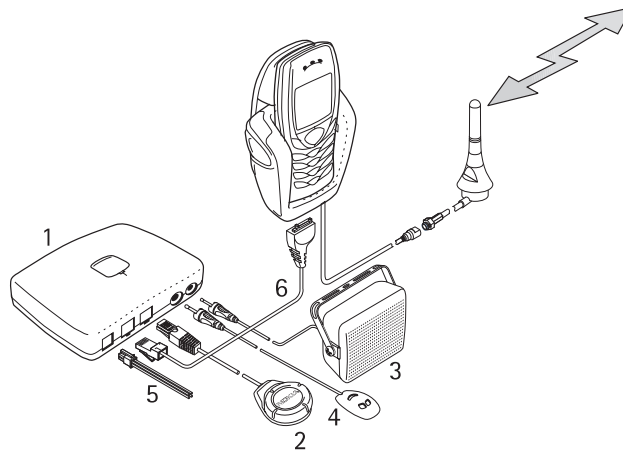

• INSTALLATION DE L'ENSEMBLE ÉVOLUÉ POUR VOITURE CK-7W

Reportez-vous à Introduction à la page 2 pour un exemple d'installation appropriée de l'ensemble évolué pour voiture.

Unité mains libres

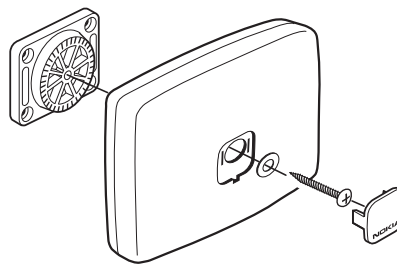

Lors de l'installation de l'unité mains libres, assurez-vous que les câbles du microphone et du haut-parleur peuvent atteindre les endroits choisis pour le montage de ces composants.

Évitez de monter l'unité mains libres à l'intérieur d'un logement métallique fermé ou à un autre emplacement susceptible de bloquer les ondes radio, ce qui pourrait compromettre la connexion sans fil Bluetooth.

Pour monter l'unité, installez d'abord la plaque de montage fournie avec l'ensemble évolué pour voiture, puis fixez l'unité mains libres à l'aide de la vis transversale. Enfin, insérez la plaque arborant le logo Nokia dans la cavité et enfoncez-la en place.

Bouton de télécommande

Le bouton de télécommande doit être placé à portée de la main de l'utilisateur. Cependant, il faut également s'assurer que son câble peut être connecté à l'unité mains libres. La console qui se trouve entre les deux sièges avant peut s'avérer un bon emplacement de montage pour le bouton de télécommande.

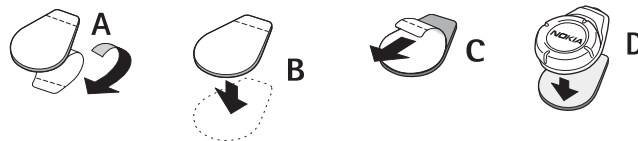



Installation

Pour monter le bouton de télécommande, utilisez l'attache Velcro fournie. Commencez par séparer les deux parties de l'attache. Installez d'abord la partie comportant des boucles : détachez la feuille protectrice de la face adhésive (A) et collez l'attache à l'emplacement désiré dans la voiture (B). Assurez-vous que la surface destinée à recevoir l'attache est bien sèche et exempte de saleté ou de poussière.

Installez ensuite la partie comportant des crochets : détachez la feuille protectrice de la face adhésive (C) et collez l'attache au dos du bouton de télécommande.

Fixez le bouton de télécommande (D) à l'attache Velcro installée dans le véhicule en le pressant fermement contre celle-ci.

Haut-parleur

Pour assurer une bonne acoustique, orientez le haut-parleur dans la direction de l'utilisateur. Il est recommandé de placer le haut-parleur à une distance minimale de 1 m (3,28 pi) du microphone afin d'éviter toute réaction acoustique.

L'ensemble évolué pour voiture peut également être connecté à une autoradio compatible. Si vous désirez utiliser l'autoradio installée dans votre véhicule pour la sortie audio de l'ensemble évolué pour voiture, consultez votre technicien à ce sujet.

Connectez le haut-parleur ou une autoradio compatible à la sortie SPEAKER (haut-parleur).

Microphone

Un choix judicieux d'emplacement de montage peut améliorer la transmission de la voix.

Montez le microphone à environ 30 cm (11,8 po) de la tête de l'utilisateur et orientez-le de manière qu'il pointe vers sa bouche. L'expérience a montré que les meilleurs emplacements se trouvent près du rétroviseur ou du pare-soleil. Il est recommandé de garder le microphone à une distance minimale de 1 m (3,28 pi) du haut-parleur de l'ensemble évolué pour voiture afin d'éviter toute réaction acoustique.

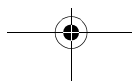
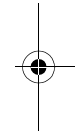
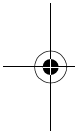

Veillez à ce que le microphone ne soit pas exposé aux jets des buses de ventilation. Ne passez pas le câble du microphone dans le système de chauffage, ventilation et climatisation. Utilisez le ruban adhésif à double face fourni pour fixer le microphone. Les propriétés isolante de ce ruban préviennent la transmission des bruits de la carrosserie à l'intérieur du véhicule.

Insérez la fiche dans la prise MIC de l'unité mains libres et tournez-la dans le sens horaire pour la verrouiller en place.



Remarque : L'utilisation d'un autre microphone que celui fourni avec l'ensemble évolué pour voiture (HFM-8) peut réduire la qualité de la captation.

Ensemble de câbles

Les fils du faisceau doivent être connectés conformément au schéma de câblage.

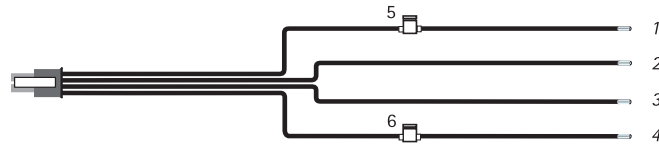

- Connectez le fil noir à la masse du véhicule (GND).
- Connectez le fil jaune à la connexion MUTE (sourdine) de l'autoradio.

Si votre autoradio ne comporte pas de connexion de mise en sourdine, ce fil peut rester déconnecté. Dans ce cas, votre autoradio ne sera pas mis en sourdine automatiquement pendant un appel.

Un relais supplémentaire peut être utilisé pour assurer cette fonction. Au moment de la réception d'un appel, l'ensemble évolué pour voiture met le fil jaune (MUTE) à la masse, ce qui coupe la sortie audio de l'autoradio. À la fin de l'appel, le fil jaune est coupé de la masse et la sortie audio de l'autoradio est rétablie.



Installation



- Connectez le fil bleu au circuit IGNS (détection d'allumage) de la voiture à l'aide du fusible 1A fourni.

Certains véhicules ne comportent pas de connexion IGNS. Ce circuit n'est pas indispensable au fonctionnement de l'ensemble évolué pour voiture; le fil bleu peut être laissé déconnecté. Dans ce cas, cependant, l'ensemble évolué pour voiture n'est pas automatiquement mis hors fonction lorsque le contact est coupé. Pour prévenir la décharge accidentelle de la batterie du véhicule, l'ensemble évolué pour voiture s'éteint automatiquement après deux minutes à moins qu'un téléphone mobile ne soit connecté au moyen de la technologie sans fil Bluetooth ou du câble de données.

- Connectez le fil rouge à la borne positive de la batterie 12V du véhicule à l'aide du fusible 2A fourni.

La fiche à quatre broches de l'ensemble de câbles se branche dans la prise DC de l'unité mains libres.

Câble de données

Le câble de données sert à raccorder l'unité mains libres à un téléphone mobile compatible (par l'intermédiaire du support de téléphone).

Branchez une extrémité du câble dans la prise PHONE de l'unité mains libres et l'autre dans le support de téléphone.

Si l'ensemble évolué pour voiture est destiné à être utilisé uniquement avec la technologie sans fil Bluetooth, il n'est pas nécessaire de brancher le câble de données.

• ESSAI DE FONCTIONNEMENT

Une fois que votre ensemble évolué pour voiture est installé, un essai doit être effectué pour en vérifier le bon fonctionnement. Pendant l'essai de fonctionnement, vérifiez également que l'installation de l'équipement ne gêne aucunement les manoeuvres nécessaires à la conduite du véhicule.

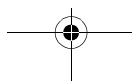



3 Mise en service de l'ensemble évolué pour voiture CK-7W

L'ensemble évolué pour voiture CK-7W permet de connecter un téléphone mobile compatible de deux façons : par liaison sans fil Bluetooth ou au moyen d'un support de téléphone compatible et d'un câble.

- **CONNEXION D'UN TÉLÉPHONE MOBILE AU MOYEN DE LA TECHNOLOGIE SANS FIL BLUETOOTH**

La première fois que vous établissez une liaison sans fil Bluetooth avec votre ensemble évolué pour voiture, vous devez coupler l'unité mains libres à votre téléphone mobile compatible. Une fois le couplage initial effectué, les deux appareils se reconnaissent mutuellement et se mettent en liaison automatiquement par la suite.



Remarque : Si vous désirez établir une connexion au moyen de la technologie sans fil Bluetooth, assurez-vous qu'aucun téléphone mobile n'est inséré dans le support de téléphone.

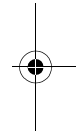
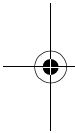

Couplage à l'aide d'un code d'authentification Bluetooth

- 1 Assurez-vous que le téléphone mobile est en fonction et que sa batterie est chargée.
- 2 Mettez l'ensemble évolué pour voiture en fonction. Pour plus d'information, reportez-vous à Mise en fonction/hors fonction de l'ensemble évolué pour voiture CK-7W à la page 18.
- 3 Ouvrez le menu Bluetooth du téléphone mobile et activez la fonction Bluetooth.
- 4 Réglez les paramètres du téléphone mobile de manière à lancer une recherche des appareils Bluetooth qui se trouvent dans sa zone de portée. Pour plus d'information sur les réglages appropriés de votre téléphone mobile, reportez-vous au guide d'utilisation pertinent.





Mise en service de l'ensemble évolué pour voiture CK-7W

- 5 Sélectionnez l'option Advanced Car Kit (ensemble évolué pour voiture) dans la liste des appareils Bluetooth repérés.
- 6 Lorsque vous êtes invité à le faire, entrez le code d'authentification Bluetooth. Ce code est inscrit sur l'étiquette apposée sur la couverture avant du présent guide.

Le code d'authentification Bluetooth se compose des quatre derniers chiffres du numéro de série de l'ensemble évolué pour voiture. Ce numéro de série figure sur l'étiquette apposée sur l'unité mains libres.

- 7 Le téléphone mobile est maintenant couplé à l'ensemble évolué pour voiture et est prêt à fonctionner.



Remarque : L'ensemble évolué pour voiture ne peut établir une connexion sans fil Bluetooth qu'avec un seul téléphone mobile compatible à la fois. Par conséquent, il peut être nécessaire de mettre fin à toute connexion sans fil existante avant d'en établir une nouvelle avec un autre téléphone mobile.

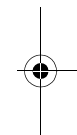
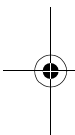

Couplage automatique à un téléphone mobile compatible

- 1 Réglez les paramètres appropriés du téléphone mobile de manière qu'il se mette automatiquement en liaison avec votre ensemble évolué pour voiture sans autre acceptation ou autorisation. Votre ensemble pour voiture peut être couplé à un maximum de huit téléphones mobiles compatibles. Les paramètres de chaque téléphone mobile sont stockés dans la mémoire de l'ensemble pour voiture afin de faciliter leur utilisation ultérieure. Pour plus d'information sur les réglages appropriés de votre téléphone mobile, reportez-vous au guide d'utilisation pertinent.
- 2 Mettez l'ensemble évolué pour voiture en fonction.
- 3 L'ensemble évolué pour voiture déclenche une recherche automatique de 30 secondes des différents téléphones mobiles auxquels il a déjà été couplé (jusqu'à sept) et dont il conserve les paramètres en mémoire. Par défaut, l'ensemble est couplé au dernier téléphone mobile auquel il a été connecté. Lorsque le processus de recherche Bluetooth est en cours, le voyant sur le bouton de télécommande clignote.

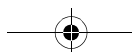



- **CONNEXION D'UN TÉLÉPHONE MOBILE AU MOYEN DU CÂBLE DE DONNÉES**

Si vous utilisez ce type de connexion, le téléphone mobile est prêt à fonctionner avec l'ensemble évolué pour voiture dès qu'il est inséré dans le support de téléphone; aucun autre couplage n'est nécessaire.

Lorsqu'un téléphone mobile est inséré dans un support de téléphone raccordé à l'ensemble évolué pour voiture au moyen du câble de données, ce téléphone est l'appareil actif et aucune liaison sans fil Bluetooth ne peut être établie avec un autre appareil. Si un téléphone mobile engagé dans une communication sans fil Bluetooth active est inséré dans un support de téléphone raccordé à l'ensemble évolué pour voiture CK-7, la connexion sans fil Bluetooth est coupée immédiatement.

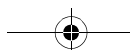
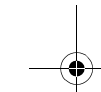
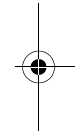
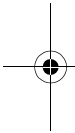

4 Fonctionnement

L'ensemble évolué pour voiture CK-7W peut être commandé par le bouton de télécommande ou par le clavier du téléphone mobile compatible.

• BOUTON DE TÉLÉCOMMANDE

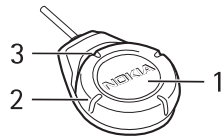

1 Le bouton permet les commandes suivantes :

- Pression brève
- Pression prolongée (environ 1 seconde)
- Double pression rapide
- Pression maintenue (plus de 10 secondes)

2 L'anneau permet les commandes suivantes :

- Rotation vers la gauche
- Rotation vers la droite

3 Le voyant comporte trois états :

- Allumé
- Clignotant
- Éteint



- **MISE EN FONCTION/HORS FONCTION DE L'ENSEMBLE ÉVOLUÉ POUR VOITURE CK-7W**

Si le fil de détection d'allumage est connecté, l'ensemble évolué pour voiture est automatiquement mis en fonction lorsque vous tournez la clé de contact de votre véhicule. Le voyant s'allume pour indiquer que l'ensemble évolué pour voiture est activé. Lorsque vous coupez le contact, l'ensemble évolué pour voiture est désactivé et le voyant s'éteint. Pour savoir si la détection d'allumage (IGNS) fonctionne avec votre véhicule et votre téléphone, vérifiez la compatibilité de ce dernier dans le guide d'utilisation pertinent.

Si l'ensemble évolué pour voiture a été installé sans connecter le fil de détection d'allumage (IGNS), pour mettre l'ensemble évolué pour voiture en fonction, exercez une pression brève sur le bouton ou insérez un téléphone mobile compatible dans le support de téléphone, le cas échéant.



Remarque : Si l'ensemble évolué pour voiture a été installé sans connecter le fil de détection d'allumage (IGNS), une fois qu'il a été mis en fonction, il le reste tant qu'un téléphone mobile compatible se trouve dans le support de téléphone.

Lorsque aucune connexion courante n'est établie avec un téléphone mobile, l'ensemble évolué pour voiture se met automatiquement hors fonction après 2 minutes.

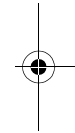
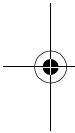

- **UTILISATION DE L'ENSEMBLE ÉVOLUÉ POUR VOITURE CK-7W**

Le bouton de télécommande permet d'exécuter les fonctions téléphoniques suivantes :

Réception d'un appel

Pour accepter un appel entrant, exercez une pression brève sur le bouton.

Conclusion d'un appel

Pour mettre fin à un appel actif, exercez une pression brève sur le bouton.

Refus d'un appel

Si vous ne désirez pas recevoir un appel, maintenez le bouton enfoncé.

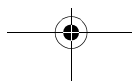



Fonctionnement

Établissement d'un appel

Sélectionnez l'entrée désirée dans le répertoire du téléphone mobile ou tapez le numéro sur le clavier du téléphone.

Recomposition

Pour recomposer un numéro récemment appelé, exercez une double pression rapide sur le bouton.

Composition vocale

Vous pouvez utiliser les marques vocales que vous avez enregistrées dans votre téléphone mobile :

- 1 Pour amorcer la composition vocale, maintenez le bouton enfoncé jusqu'à ce que vous entendiez une tonalité.
- 2 Dicter la marque vocale.
- 3 Le téléphone mobile fait entendre la marque vocale et compose le numéro de téléphone correspondant.

Pour plus de détails sur la composition vocale, reportez-vous au guide d'utilisation de votre téléphone mobile.



Remarque : Certains téléphones mobiles peuvent ne pas supporter toutes les fonctions décrites dans le présent guide.

Réglage du volume

Pour régler le volume du haut-parleur, tournez l'anneau.

Recherche manuelle d'appareils Bluetooth

Si aucune liaison n'est couramment établie avec un téléphone mobile, vous pouvez lancer une recherche manuelle pour repérer un téléphone mobile doté de la technologie sans fil Bluetooth.

Pour activer la fonction de recherche Bluetooth de l'ensemble évolué pour voiture, maintenez le bouton enfoncé.

Le voyant commence à clignoter pour indiquer que la recherche d'appareils Bluetooth est lancée.

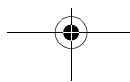



Remise à zéro de la liste des appareils couplés

L'ensemble évolué pour voiture enregistre le dernier appareil Bluetooth auquel il a été couplé.

La liste des appareils Bluetooth couplés peut cependant être effacée. Pour effacer la liste, l'ensemble évolué pour voiture doit être mis hors fonction (voyant éteint).

Maintenez le bouton enfoncé jusqu'à ce qu'une tonalité indique que la liste a été effacée.

Passage du mode mains libres au téléphone mobile

- Lorsqu'un téléphone mobile compatible est raccordé à l'ensemble évolué pour voiture au moyen du câble de données, retirez le téléphone du support pour passer du mode mains libres de l'ensemble pour voiture au téléphone mobile.
- Pour revenir au mode mains libres de l'ensemble pour voiture, remettez le téléphone mobile dans le support. Le téléphone mobile fonctionne maintenant en mode mains libres grâce à l'ensemble évolué pour voiture.
- Lorsqu'un téléphone mobile compatible est connecté à l'ensemble évolué pour voiture au moyen de la technologie Bluetooth, vous pouvez commuter l'appel en cours entre l'ensemble évolué pour voiture et le téléphone mobile. Maintenez le bouton enfoncé ou utilisez la fonction correspondante de votre téléphone mobile.

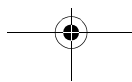
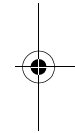
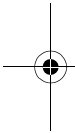



Fonctionnement



Précautions d'utilisation et maintenance

Votre ensemble évolué pour voiture CK-7W est un produit de conception et de fabrication supérieures qui doit être traité avec soin. Les suggestions qui suivent vous aideront à assurer la validité de votre garantie et vous permettront de profiter pleinement de ce produit pendant de nombreuses années.

- Gardez tous les accessoires hors de portée des jeunes enfants.
- Gardez l'ensemble évolué pour voiture au sec. Les précipitations, l'humidité et les liquides contiennent des minéraux susceptibles de détériorer les circuits électroniques.
- N'utilisez pas et ne rangez pas l'ensemble évolué pour voiture dans un endroit poussiéreux ou sale. Ses composants risquent de se détériorer.
- N'essayez pas d'ouvrir l'ensemble évolué pour voiture. Une manipulation inappropriée risque de l'endommager.
- N'utilisez pas de produits chimiques durs, de solvants ou de détergents puissants pour nettoyer l'ensemble évolué pour voiture ou le bouton de télécommande.
- Ne peignez pas l'ensemble évolué pour voiture ou le bouton de télécommande. La peinture risque d'encrasser ses composants et d'en gêner le fonctionnement.

En cas de mauvais fonctionnement de l'ensemble évolué pour voiture ou du bouton de télécommande, apportez le composant défectueux au centre de réparation autorisé le plus près. Ce service vous conseillera et prendra les dispositions appropriées au besoin.

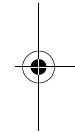
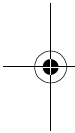



Nokia – Garantie limitée de 1 an (Canada)

Nokia garantit cet appareil Nokia contre tout défaut de matériau et de fabrication. La durée de la garantie est de douze (12) mois à compter de la date d'achat, OU de quatorze (14) mois à compter de la date d'expédition au grossiste par Nokia, OU de quinze (15) mois à compter de la date de fabrication par Nokia.

Durant la période de la garantie, Nokia réparera ou remplacera, à sa discrétion et sans frais, l'appareil défectueux, l'appareil de remplacement pouvant être soit neuf soit réusiné ou remis à neuf.

Cependant, si Nokia détermine que les modalités de la garantie n'ont pas été respectées, les frais de réparation et d'expédition seront facturés à l'acheteur.

EXCLUSIONS

La présente garantie fait l'objet des exclusions suivantes :

- 1 Tous dommages causés par une réparation ou une tentative de réparation effectuée par un centre de service non agréé invalideront la présente garantie.
- 2 La présente garantie couvre l'utilisation normale, mais exclut tout dommage ou défaut de l'appareil qui, de l'avis de Nokia, serait la conséquence d'un mauvais entreposage, d'une exposition à l'humidité, au feu, au sable, à la saleté, à une tempête de vent, à la foudre ou à un tremblement de terre, d'un vol, d'une fuite de la batterie, de modifications non autorisées, d'une mauvaise utilisation, d'une négligence, d'un abus, d'une utilisation inappropriée, d'un accident, d'une transformation, d'une mauvaise installation, d'un mauvais réglage des commandes, de conditions de fonctionnement anormales ou d'un cas de force majeure.
- 3 Sont exclus de la présente garantie les dommages et les défauts attribuables à un produit non approuvé branché à cet appareil.
- 4 La présente garantie ne couvre que les appareils achetés par l'intermédiaire de la société Nokia Products Ltd. installée à Ajax (Ontario), au Canada, et vendus au Canada et aux Bermudes.

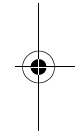
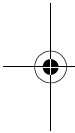



Nokia se dégage de toute responsabilité de quelque nature que ce soit à l'égard des dommages accessoires, spéciaux, directs ou indirects, de la perte de bénéfices ou de profits projetés, de la perte d'usage de l'appareil, résultant de l'utilisation du présent appareil ou de ses accessoires, ou de toute inobservation de la présente garantie.

MARCHE À SUIVRE – APPAREIL DÉFECTUEUX

Pour obtenir un service en garantie, retournez l'appareil défectueux à un centre de service Nokia en port payé (les frais d'expédition de l'appareil réparé peuvent, dans certains cas, être assumés par Nokia, ainsi que les risques de perte ou de dommage au cours de l'expédition).

La preuve de date d'achat est nécessaire avant que tout service prévu dans la présente garantie ne soit fourni.

Les services d'entretien et de réparation pour ces appareils peuvent être obtenus dans tout centre agréé au Canada.

PROLONGATION DE LA GARANTIE

Si une réparation est effectuée, une garantie supplémentaire de 90 jours sera offerte sur les pièces et la main-d'oeuvre, ainsi que sur toute unité remplacée, le cas échéant.

Outre cette garantie supplémentaire de 90 jours, les réparations et remplacements en garantie ne modifient pas la durée initiale d'application de la garantie sur les autres pièces, laquelle est déterminée par la date d'achat.

LA PRÉSENTE GARANTIE CONSTITUE LE SEUL ET UNIQUE RECOURS DE L'ACHETEUR ET REMPLACE TOUTES LES AUTRES GARANTIES EXPRESSES OU IMPLICITES, NOTAMMENT TOUTES LES GARANTIES IMPLICITES DE VALEUR MARCHANDE OU D'ADÉQUATION À UNE FIN OU À UN USAGE PARTICULIERS.

Certaines provinces ne permettent pas que la durée des garanties implicites soit limitée; il est donc possible que les limitations ne s'appliquent pas à votre cas.

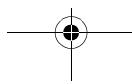
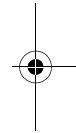
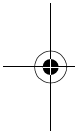



POUR CONNAÎTRE LES CENTRES DE SERVICE, COMMUNIQUEZ AVEC
VOTRE FOURNISSEUR DE SERVICES/DÉTAILLANT/DISTRIBUTEUR OU
DIRECTEMENT AVEC NOKIA À L'ADRESSE SUIVANTE :

NOKIA PRODUCTS LIMITED
601 Westney Road South
Ajax, Ontario L1S 4N7
Tél. : (905) 427-1373
1 888 226-6542
Site Web : www.nokia.ca

Si un produit doit être retourné à Nokia ou à tout centre de service agréé
de Nokia, le fournisseur de services/détaillant/distributeur devra assumer
les frais d'expédition, les taxes, les frais de douane et l'assurance. Nokia
n'assume aucun risque de perte ou de dommage au cours de l'expédition.

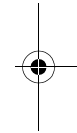
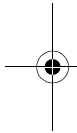

NOKIA

© Nokia 2004. Tous droits réservés.

Les logos Nokia et Original Enhancements sont des marques de commerce ou marques
déposées de Nokia Corporation ou de ses sociétés affiliées.

Version 1 Imprimé au Allemagne 03/04 9230761

