

Fronius Symo Installation





AVVISO! L'utilizzo improprio e l'esecuzione errata dei lavori possono causare gravi lesioni personali e danni materiali. La messa in funzione dell'inverter deve essere eseguita esclusivamente da personale qualificato e conformemente alle disposizioni tecniche. Prima della messa in funzione e dell'esecuzione dei lavori di manutenzione, è assolutamente necessario leggere il capitolo „Norme di sicurezza“.



AVVISO! Una scossa elettrica può risultare mortale. Pericolo derivante dalla tensione di rete e dalla tensione CC dei moduli solari esposti alla luce.

- Prima di eseguire qualsiasi collegamento, togliere la tensione dal lato CA e CC dell'inverter.

Il collegamento fisso alla rete elettrica pubblica deve essere realizzato esclusivamente da un elettroinstallatore autorizzato.



AVVISO! Una scossa elettrica può risultare mortale. Pericolo derivante dalla tensione di rete e dalla tensione CC dei moduli solari.

- L'interruttore principale CC serve esclusivamente per togliere corrente alla fonte d'energia. Se l'interruttore principale CC è disattivato, la scatola dei collegamenti continua a essere sotto tensione.
- Tutte le operazioni di manutenzione e assistenza devono essere eseguite soltanto quando fonte d'energia e scatola dei collegamenti sono scollegate l'una dall'altra.
- La scatola della fonte d'energia deve essere staccata dalla scatola dei collegamenti solo in assenza di tensione.
- Le operazioni di manutenzione e assistenza all'interno della fonte d'energia dell'inverter devono essere eseguite solo da personale qualificato dell'assistenza Fronius.



AVVISO! Una scossa elettrica può risultare mortale. Pericolo derivante dalla tensione residua dei condensatori. Attendere il tempo di scaricamento dei condensatori (5 minuti).



PRUDENZA! Un collegamento insufficiente con il conduttore di terra può causare gravi lesioni personali e danni materiali. Le viti del corpo esterno rappresentano un collegamento adeguato con il conduttore di terra per la messa a terra del corpo esterno e non devono in alcun caso essere sostituite da altre viti senza collegamento affidabile.



PRUDENZA! Pericolo di danneggiamento dell'inverter causato dalla presenza di impurità o acqua sui morsetti e sui contatti della scatola dei collegamenti.

- Durante l'esecuzione dei fori prestare attenzione a non sporcare o bagnare i morsetti e i contatti sulla scatola dei collegamenti.
- Il supporto da parete senza fonte d'energia non corrisponde alla classe di protezione dell'intero inverter e non può quindi essere montato senza fonte d'energia.

Durante il montaggio proteggere il supporto da parete da impurità e umidità.



PRUDENZA! Morsetti non correttamente serrati possono causare danni all'inverter. Morsetti non correttamente serrati possono causare danni termici all'inverter e di conseguenza provocare incendi. Durante il collegamento dei cavi CA e CC, prestare attenzione affinché tutti i morsetti siano ben serrati applicando la coppia prescritta.













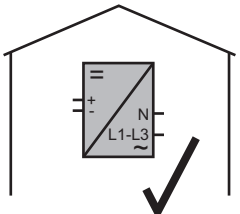



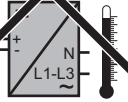
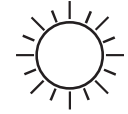
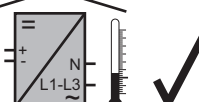

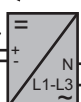
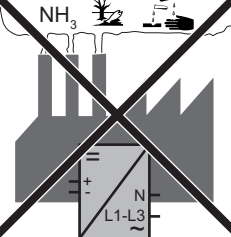
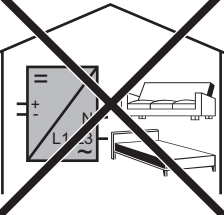
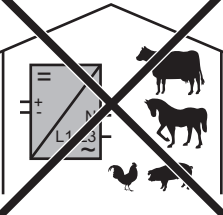
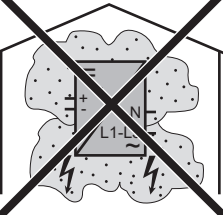

PRUDENZA! Un sovraccarico può provocare danni all'inverter.

- A ciascun morsetto CC collegare al massimo 20 A.
- Collegare i cavi CC+ e CC- rispettando la polarità corretta ai morsetti CC+ e CC- dell'inverter.

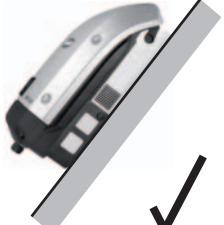

AVVERTENZA! La classe di protezione IP 55 è valida solo se l'inverter è agganciato al supporto da parete e avvitato bene a esso.
La classe di protezione del supporto da parete senza inverter è IP 20!

Fronius Symo Installation

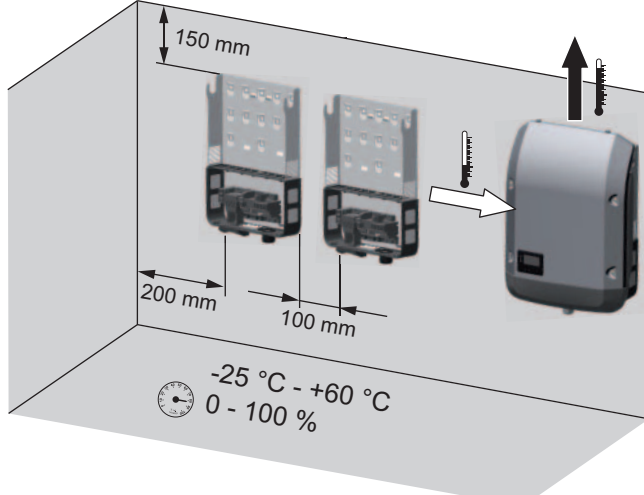
	<p>http://www.fronius.com</p> <p>Solar Electronics / Info & Support / Document Downloads / Operating Manuals / Grid-connected inverters / Fronius Symo / Installation Help</p>			
 <p>IP 55</p> 	 	 	<p>2500 m $U_{DCmax} = 900\text{ V}$</p> <p>2000 m $U_{DCmax} = 1000\text{ V}$</p> 	<p>> 3400 m</p> <p>3400 m $U_{DCmax} = 750\text{ V}$</p> <p>3000 m $U_{DCmax} = 815\text{ V}$</p> <p>2500 m</p> 
				
				
				
				

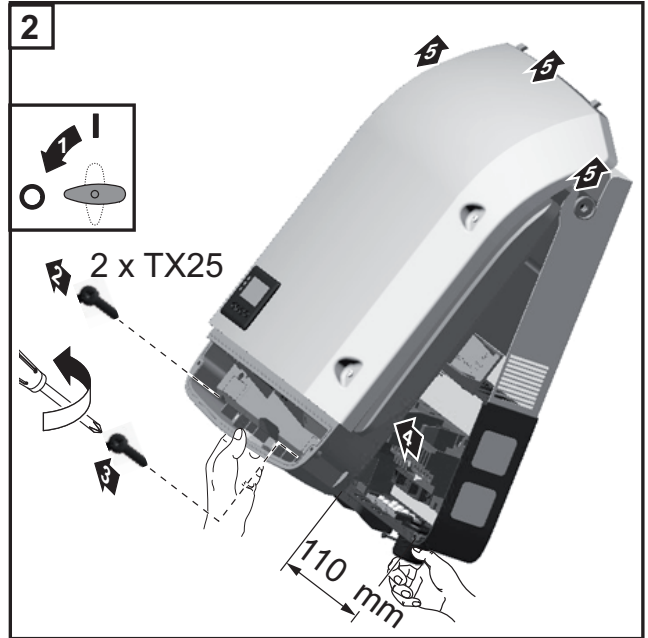
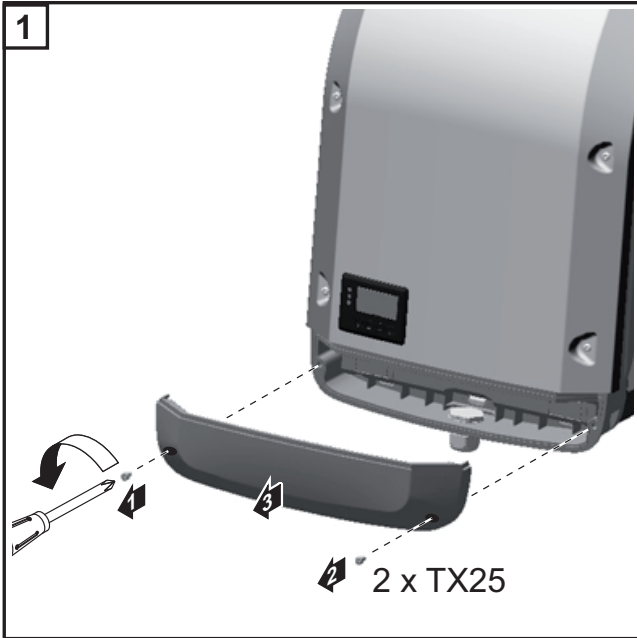

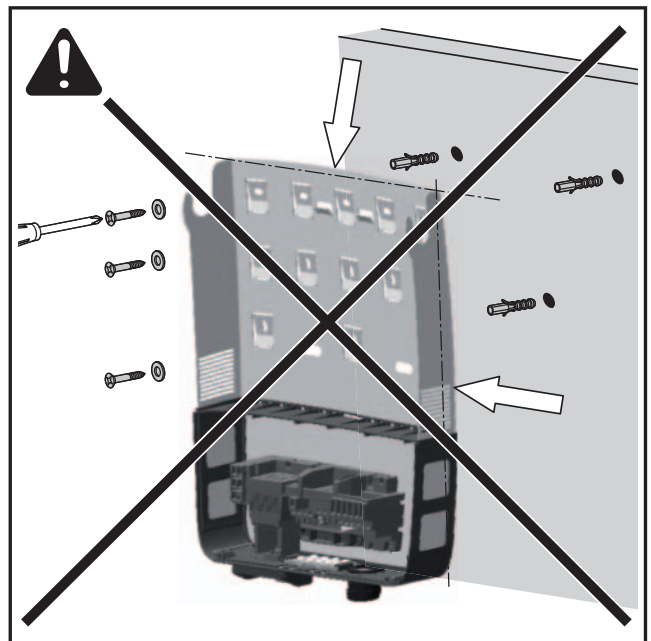
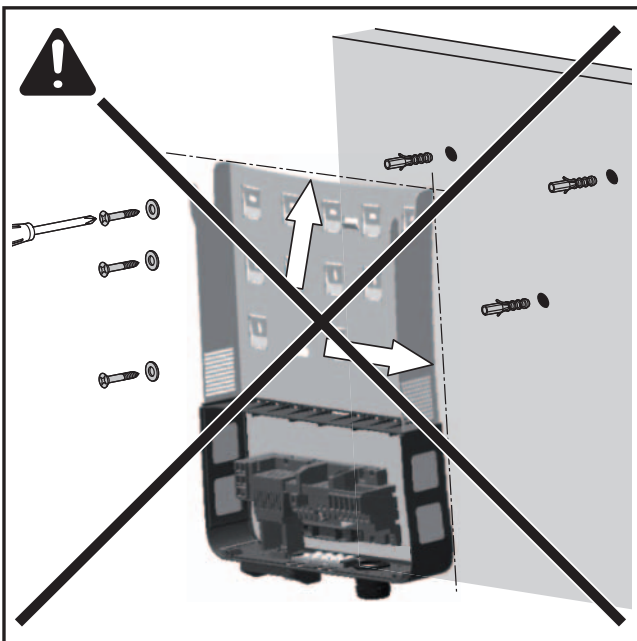
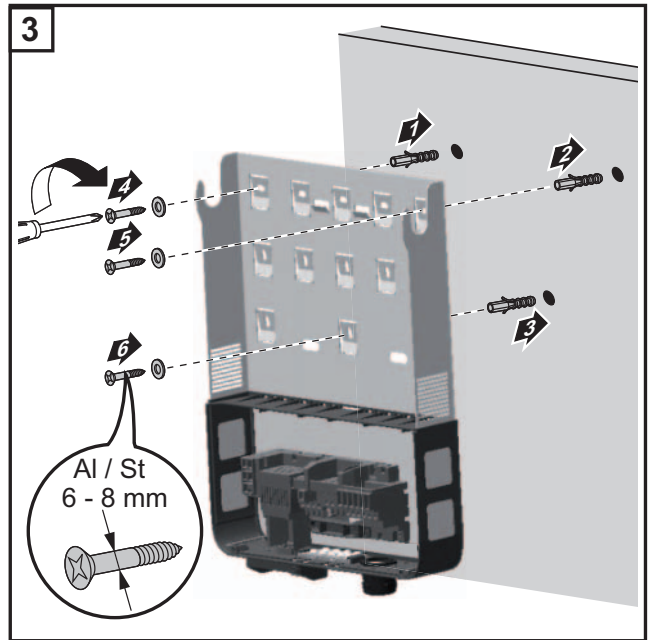
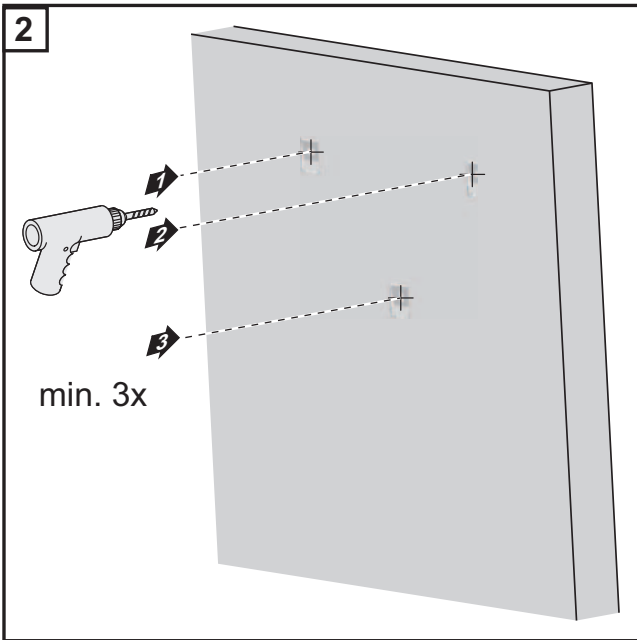
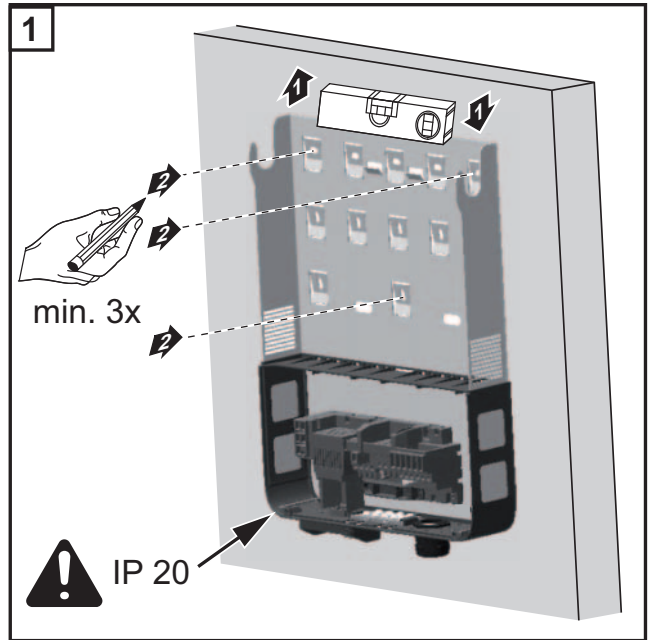

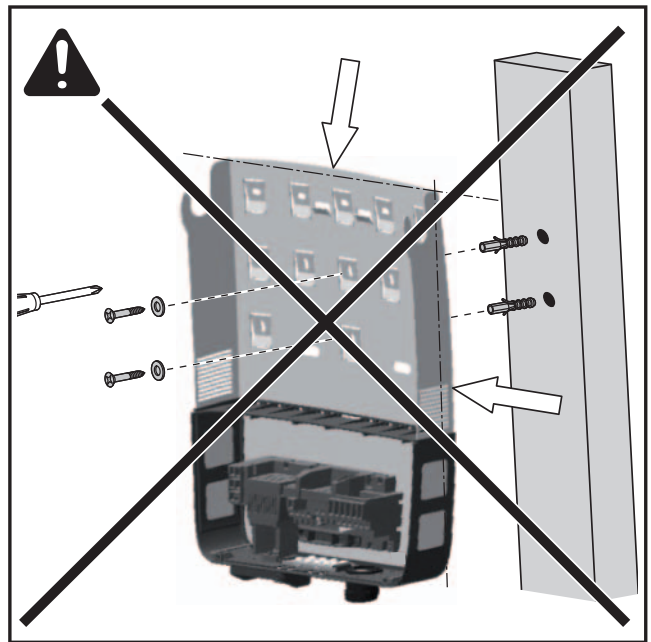
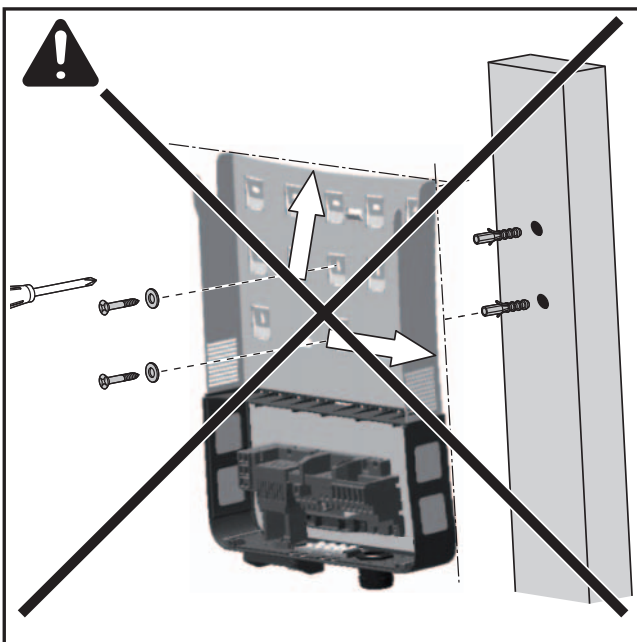
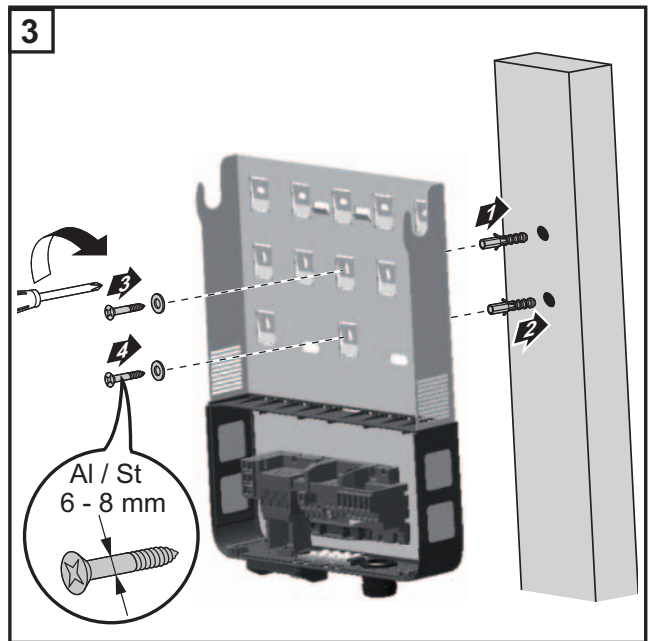
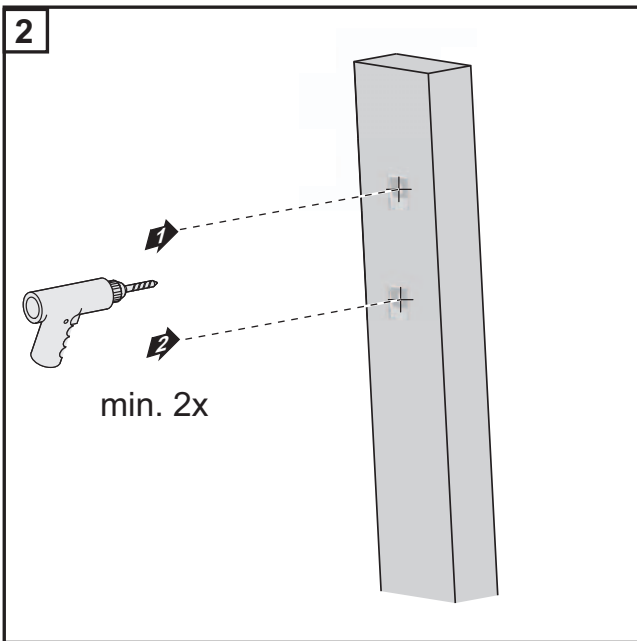
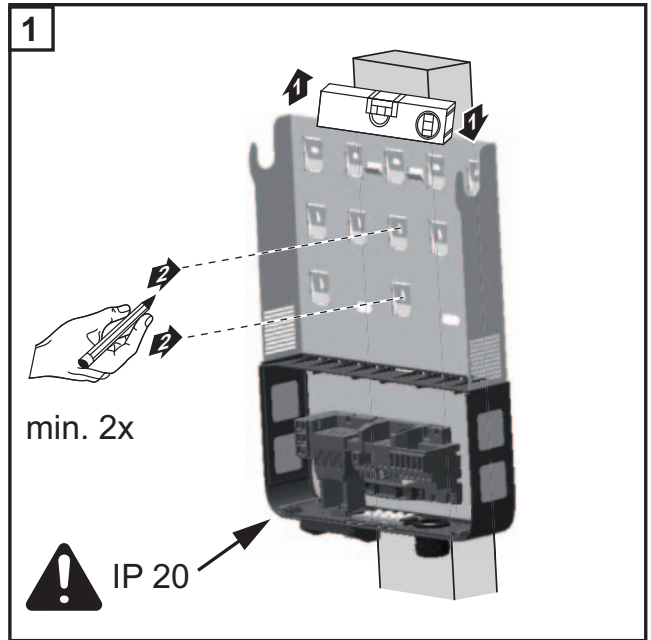
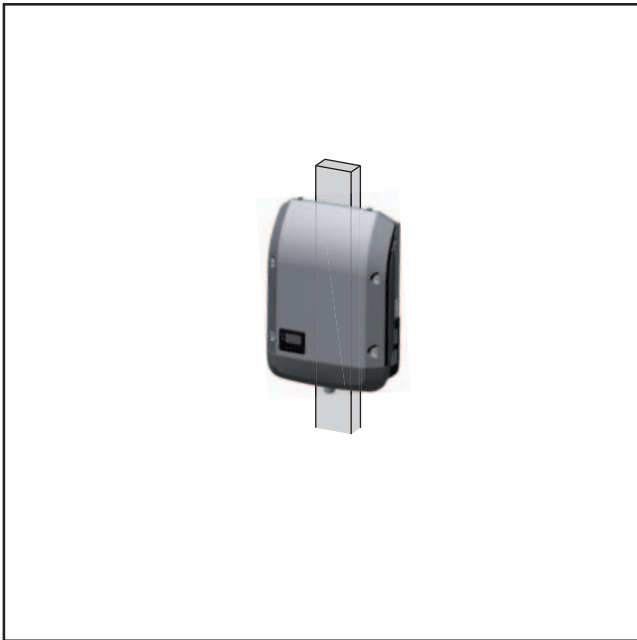

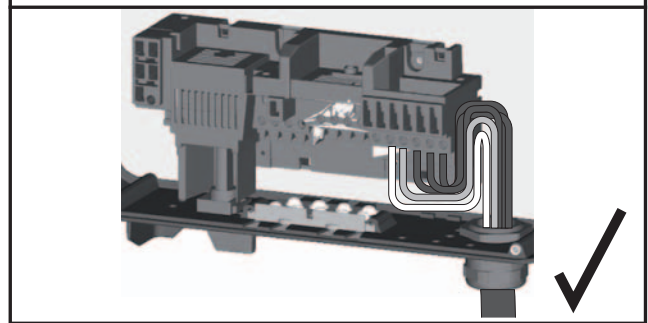
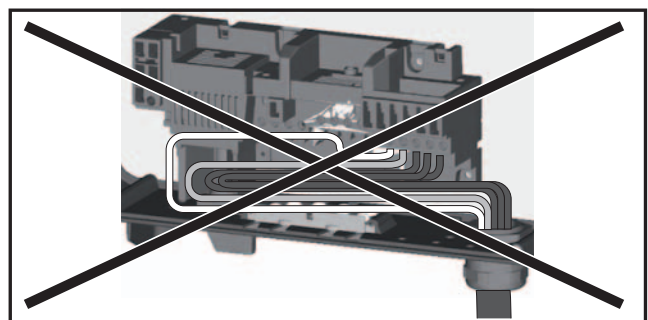
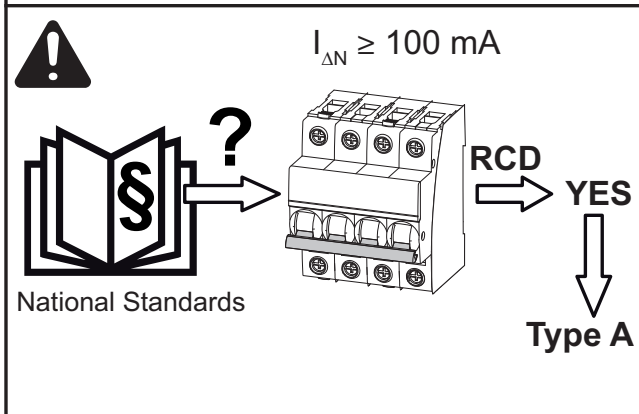
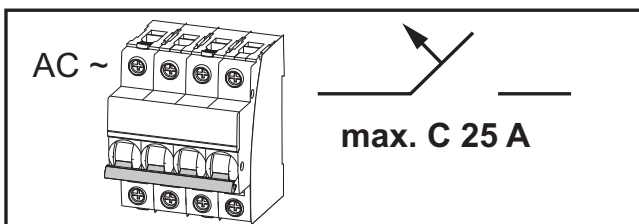
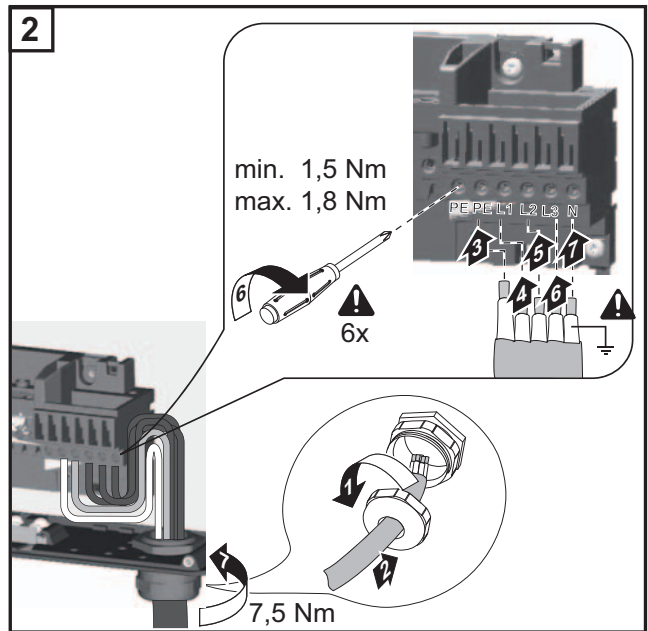
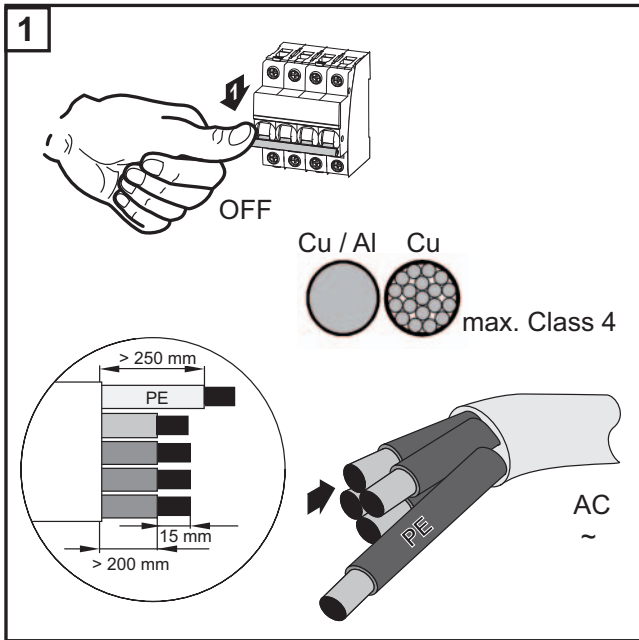
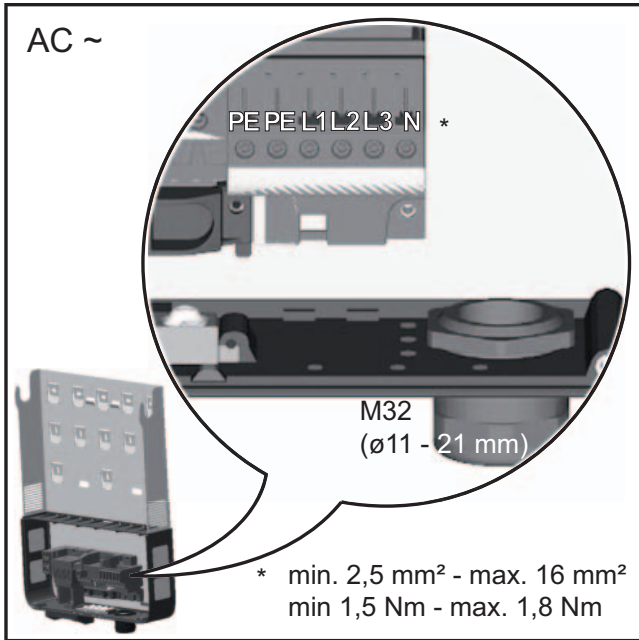

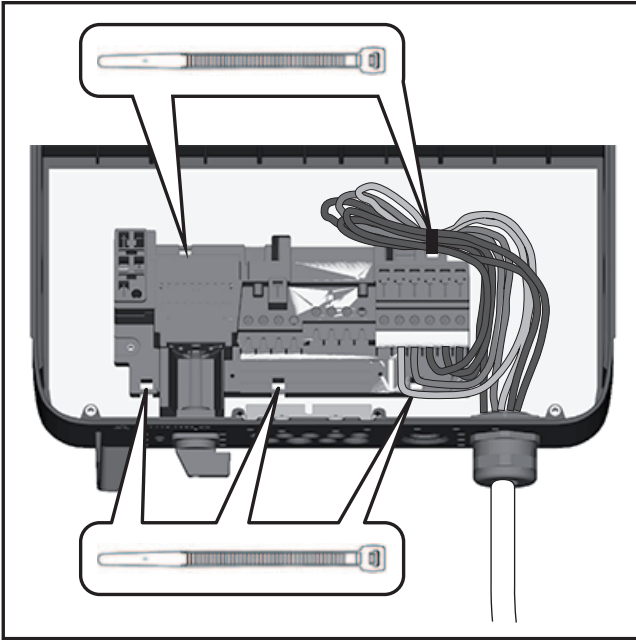

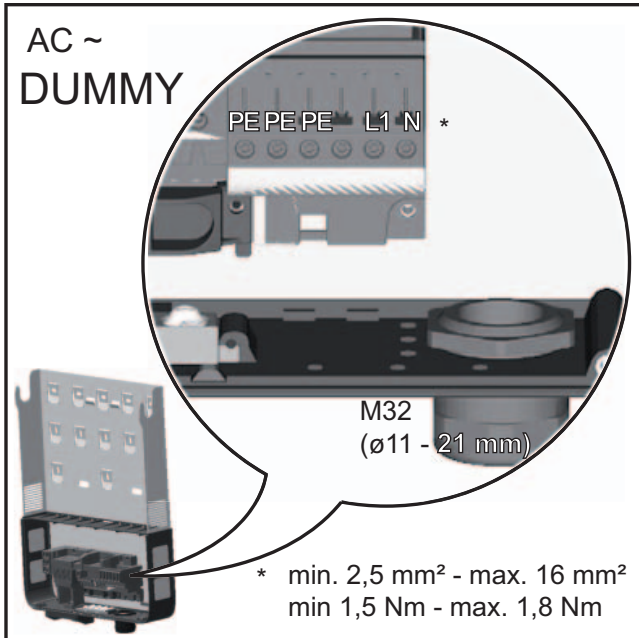

Fronius Symo Dummy

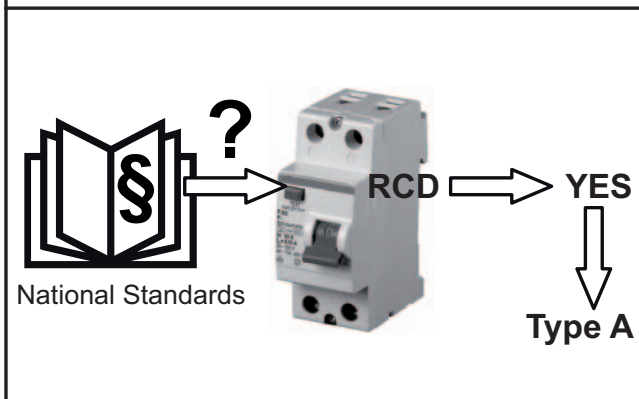
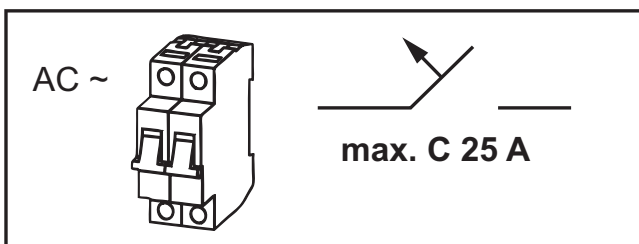
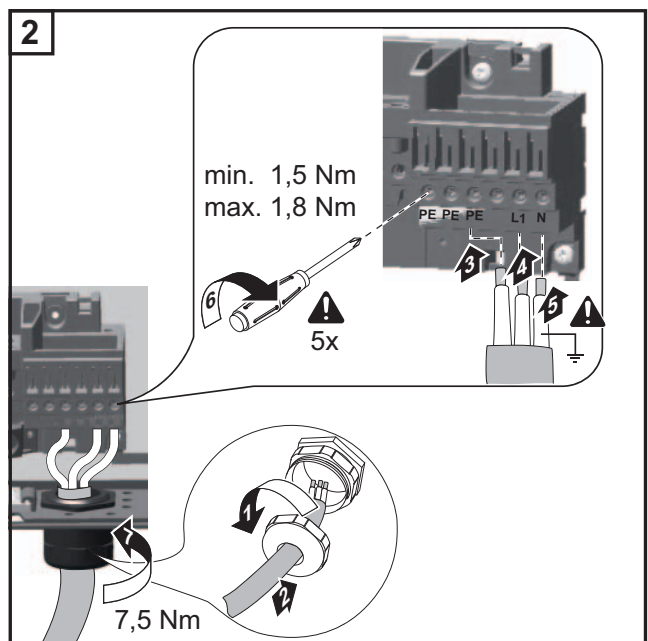
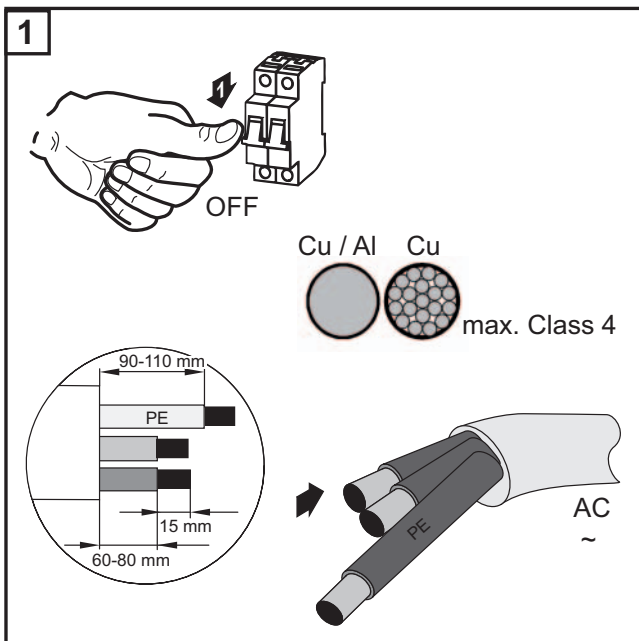
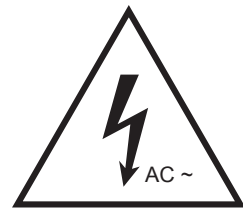

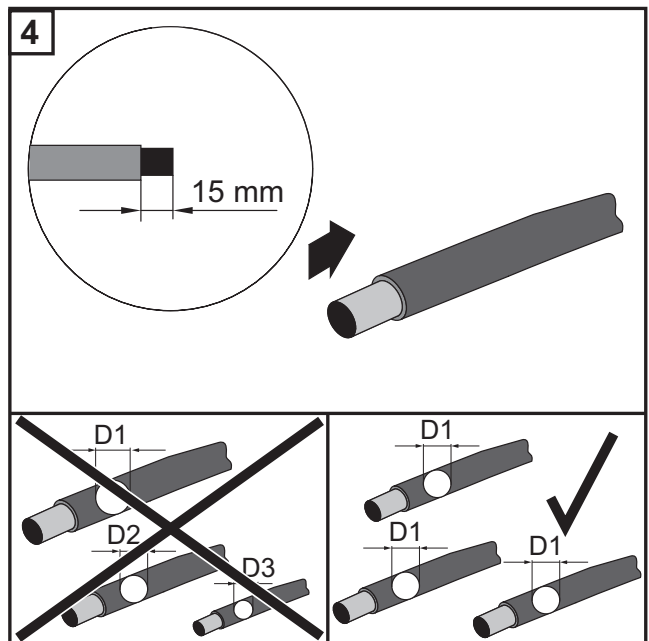
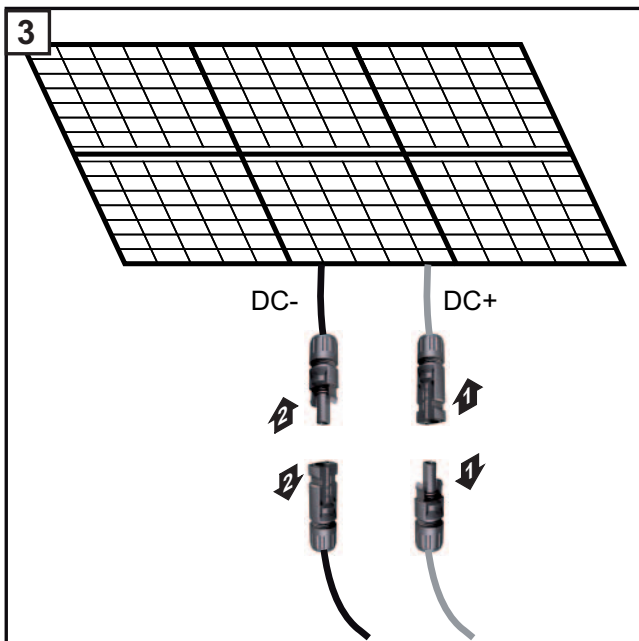
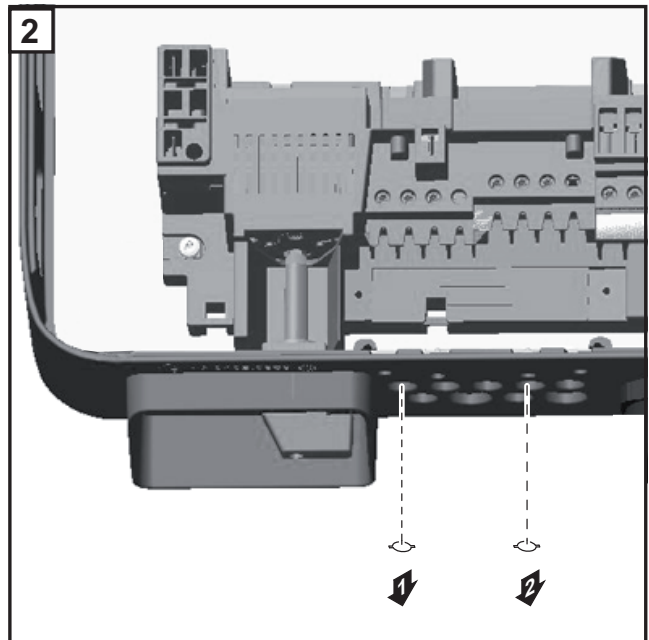
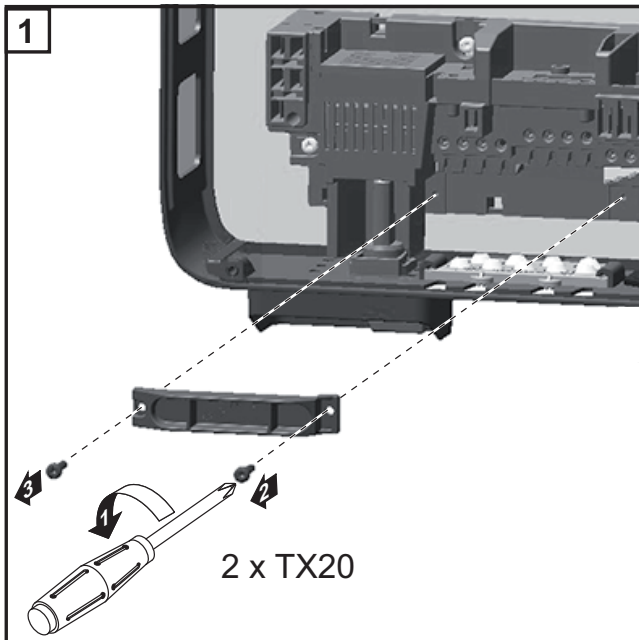
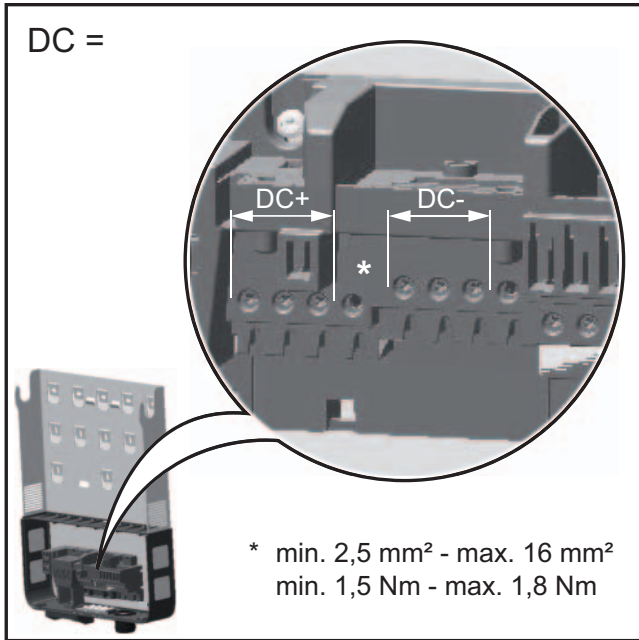

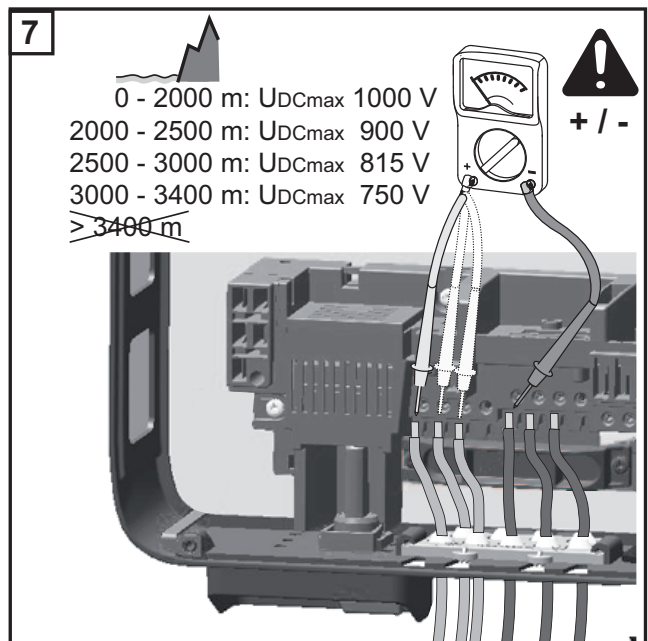
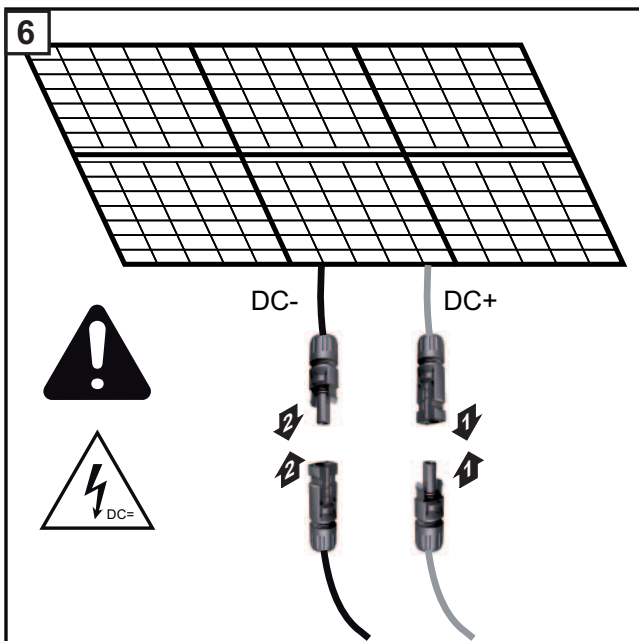
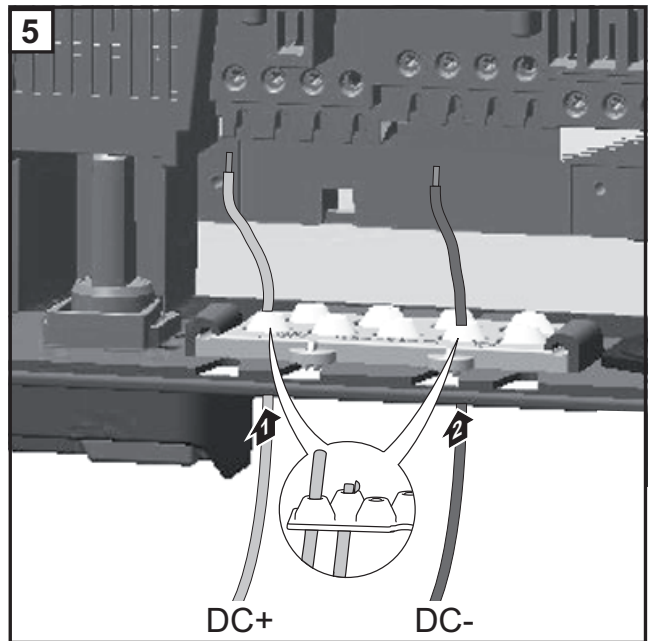
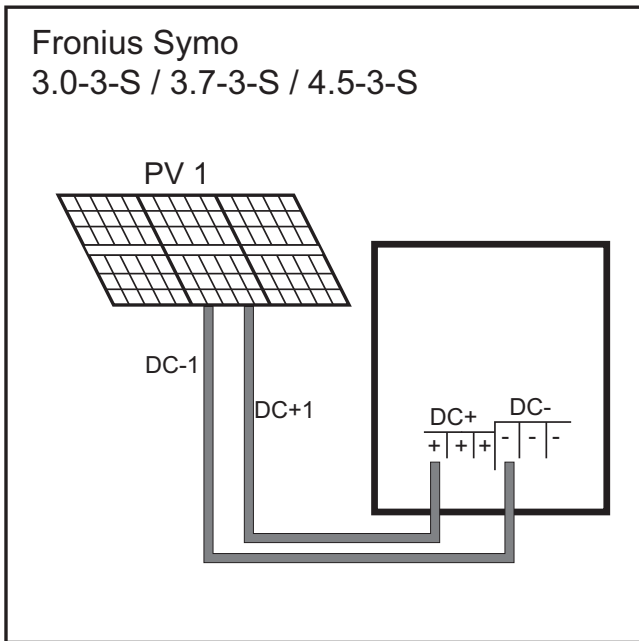
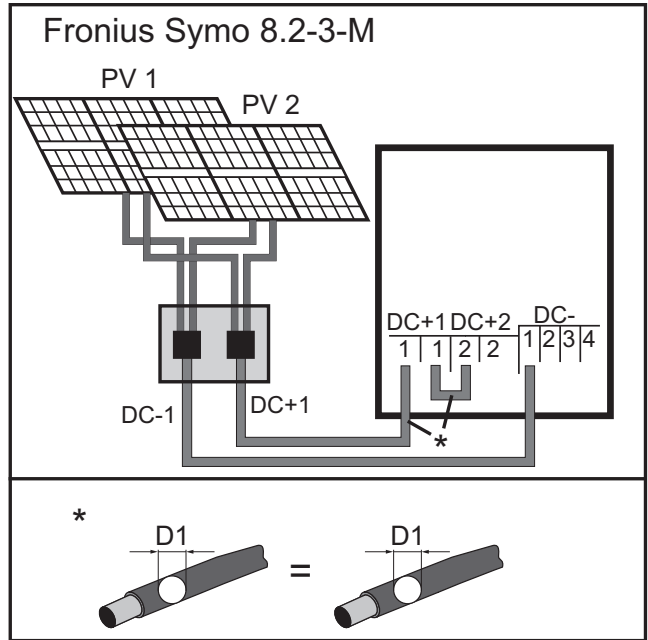
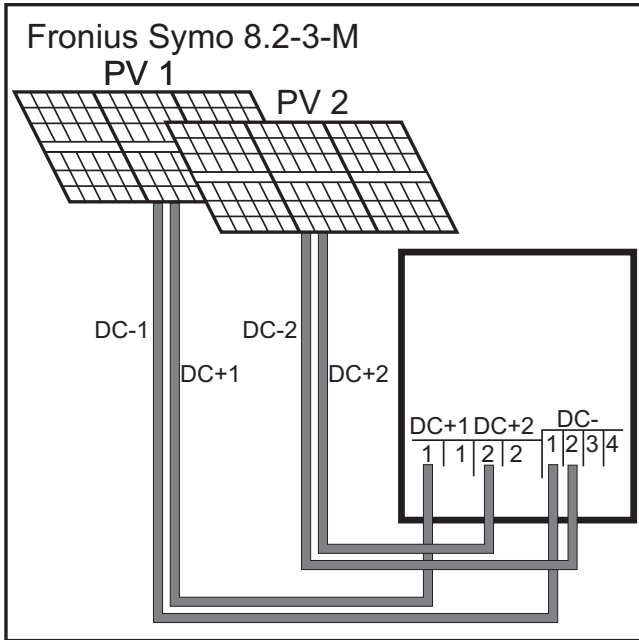

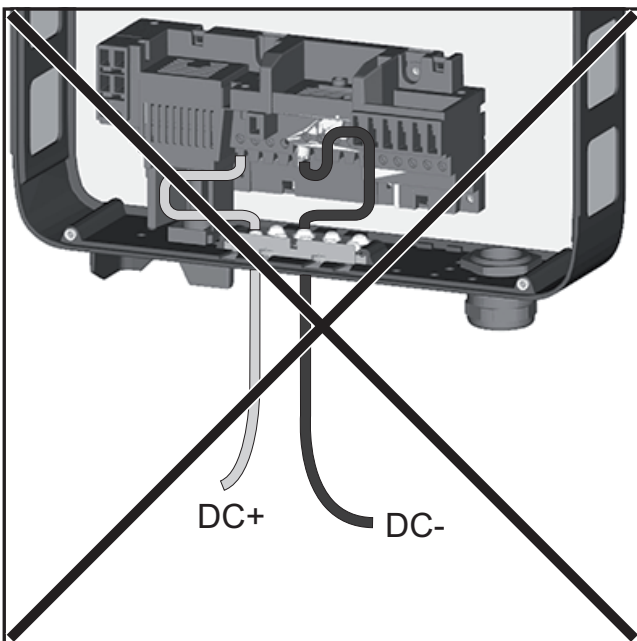
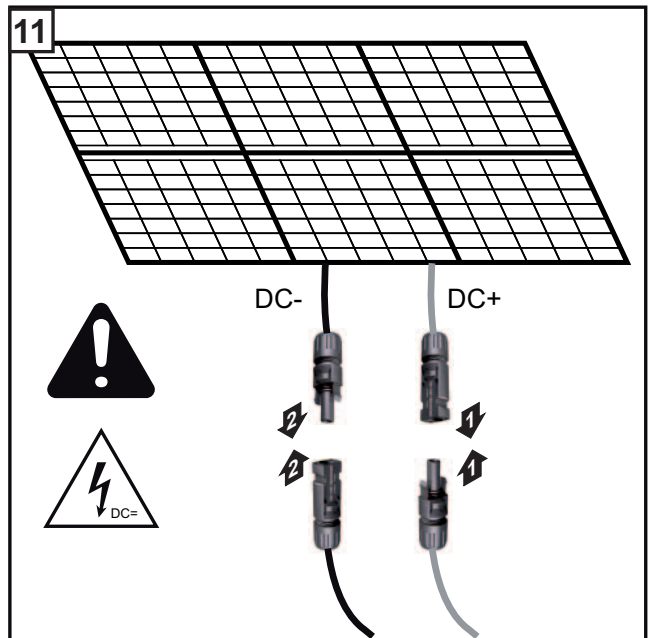
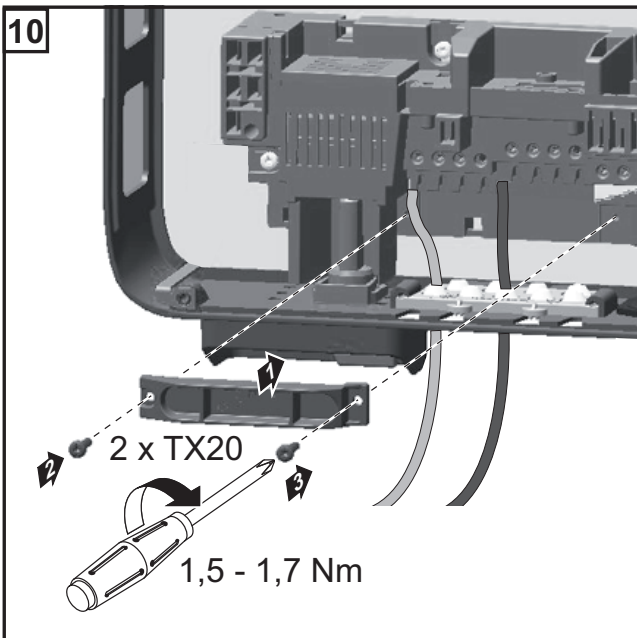
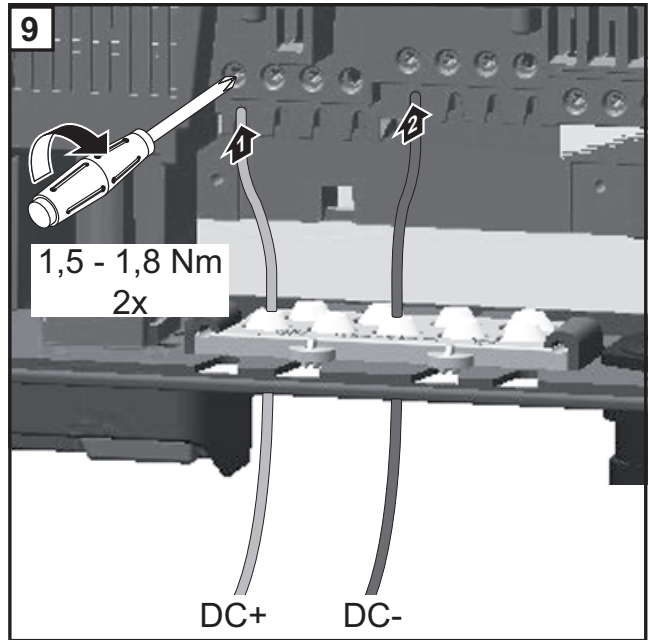
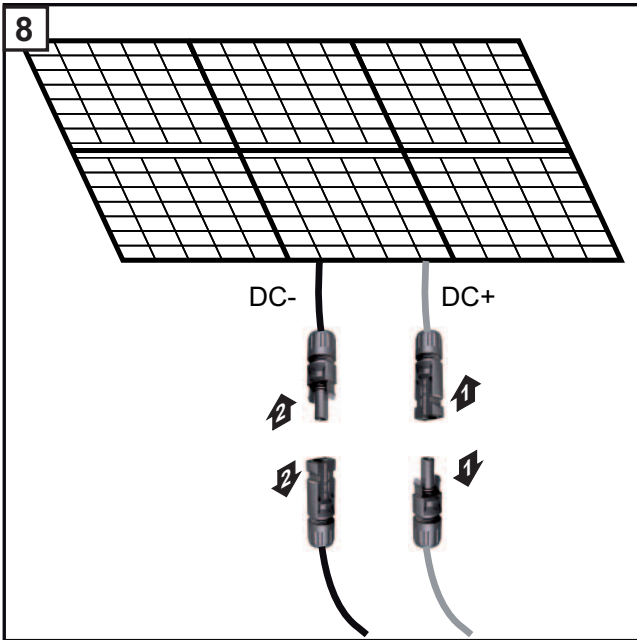

DATCOM

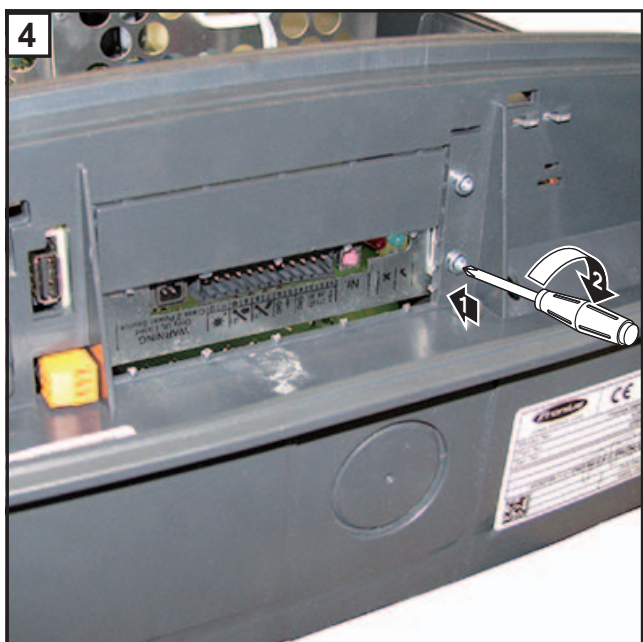
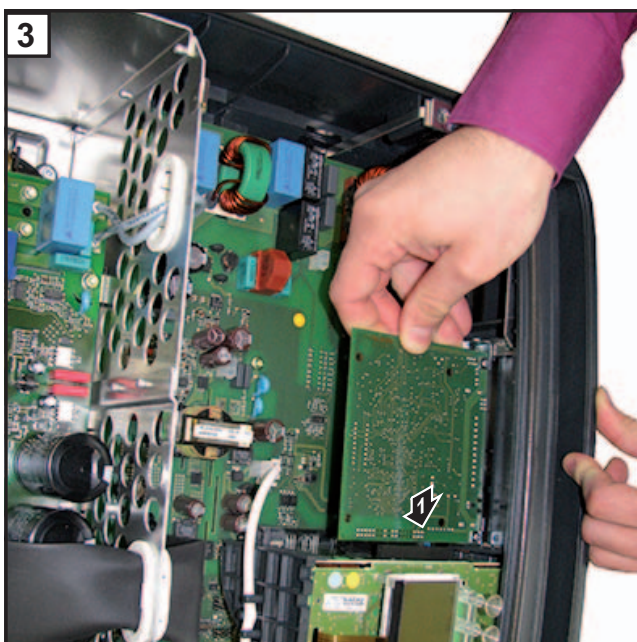
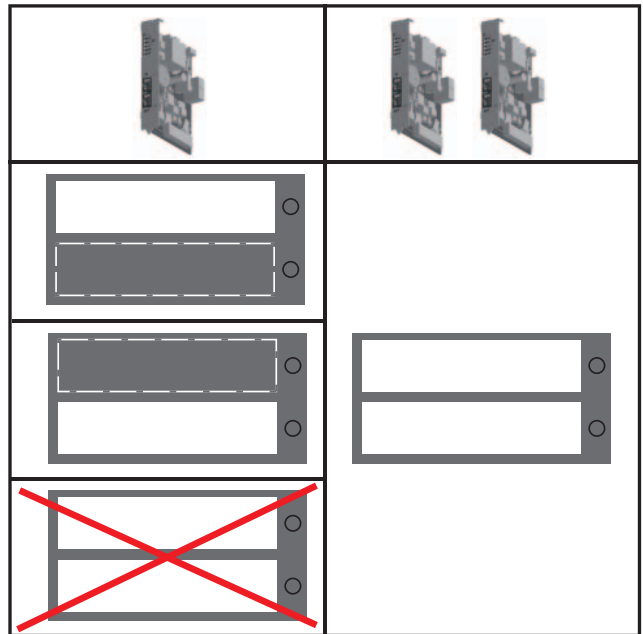
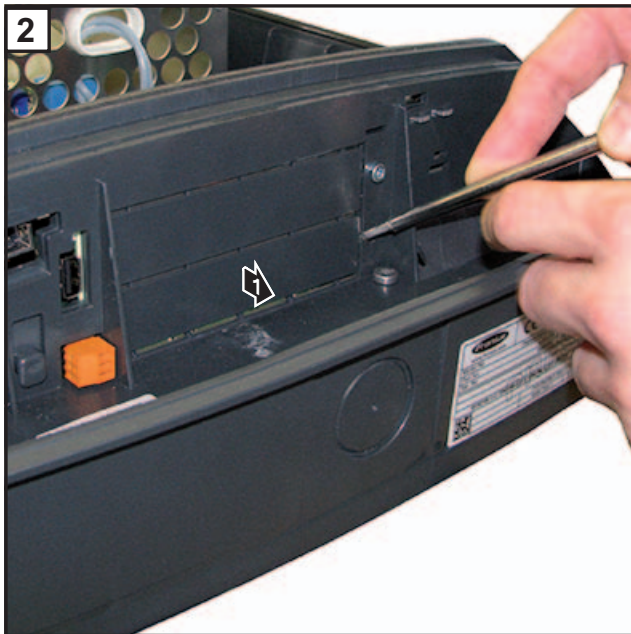
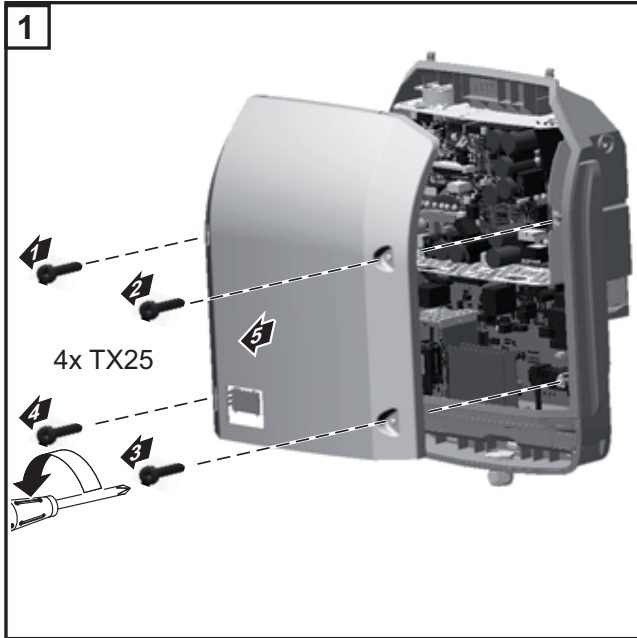

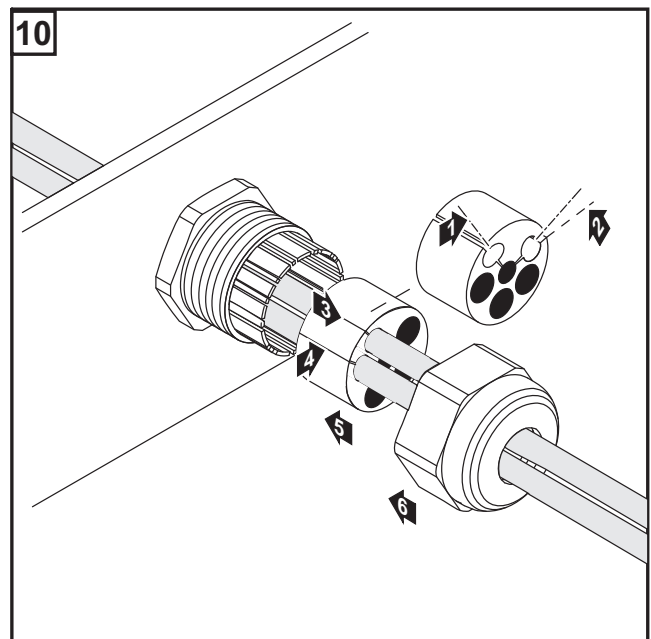
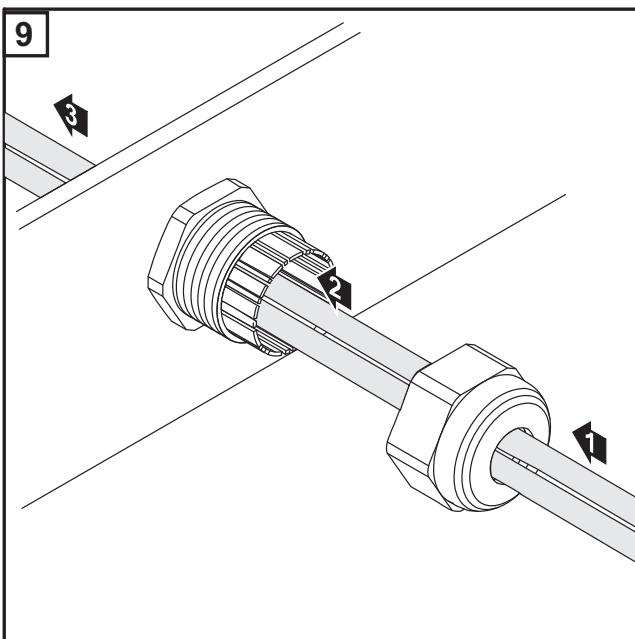
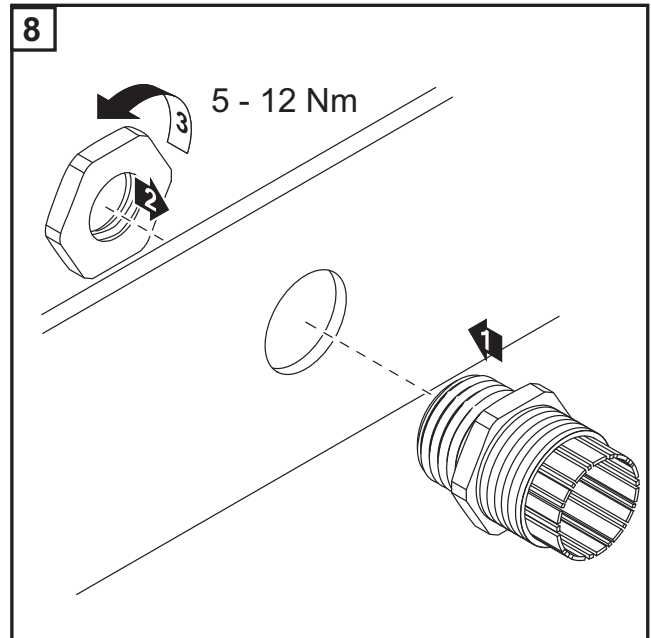
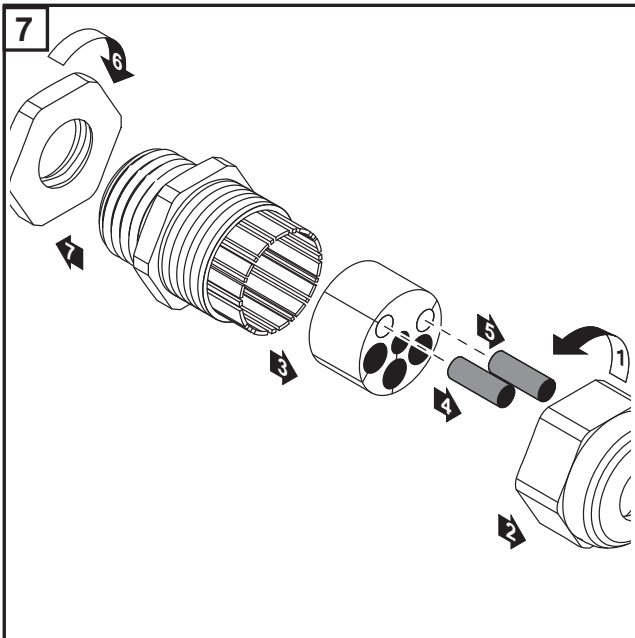
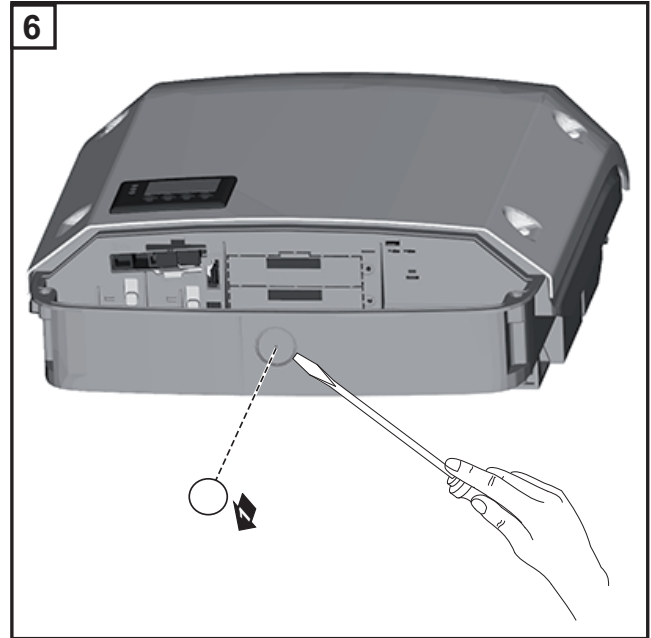
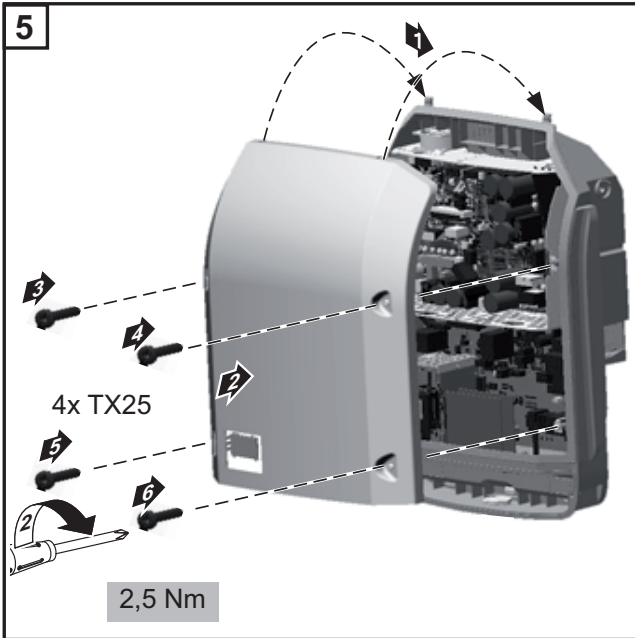

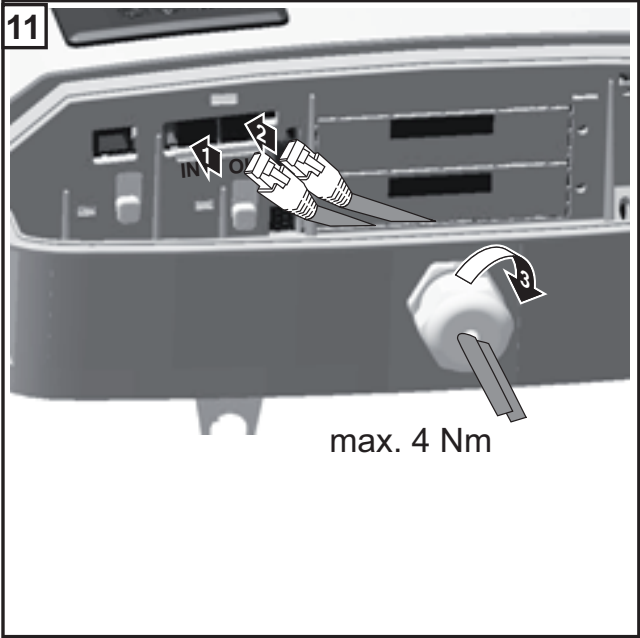

OPERATION

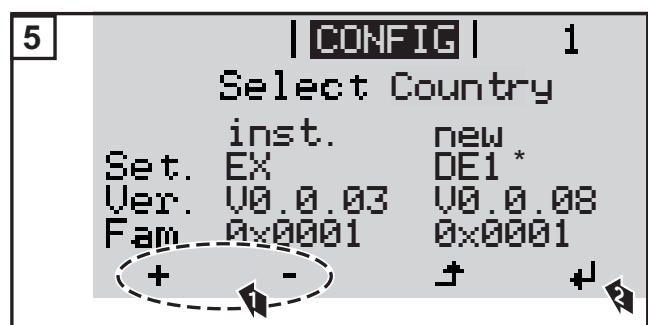
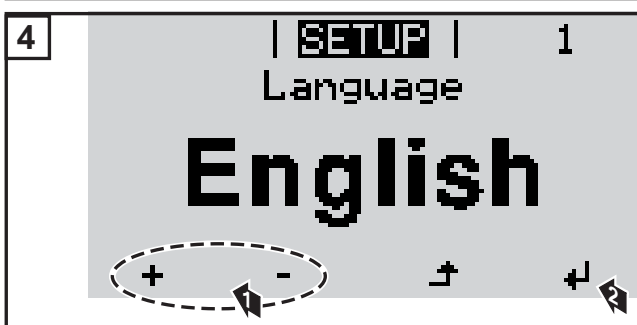
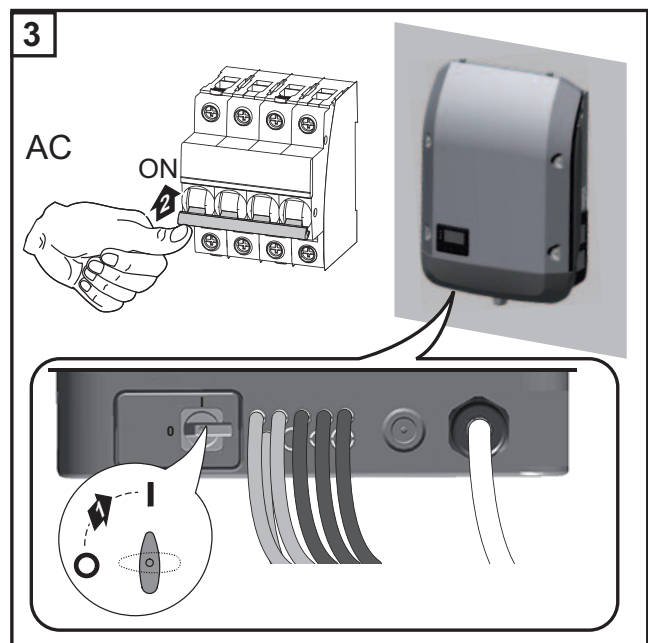
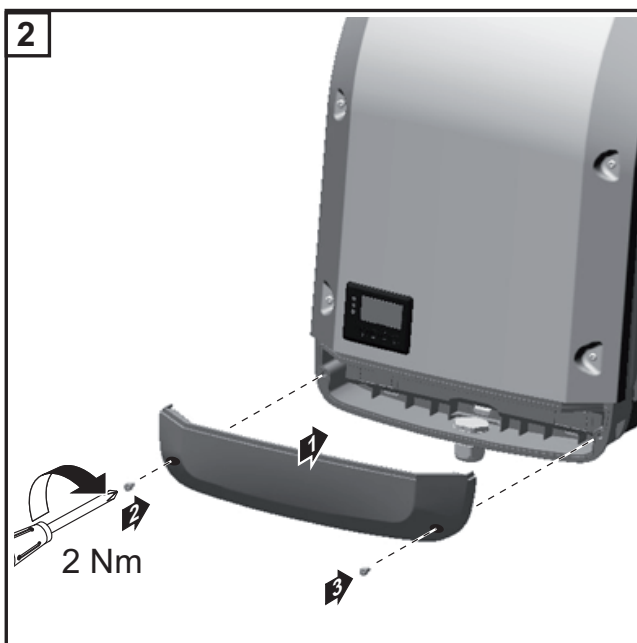
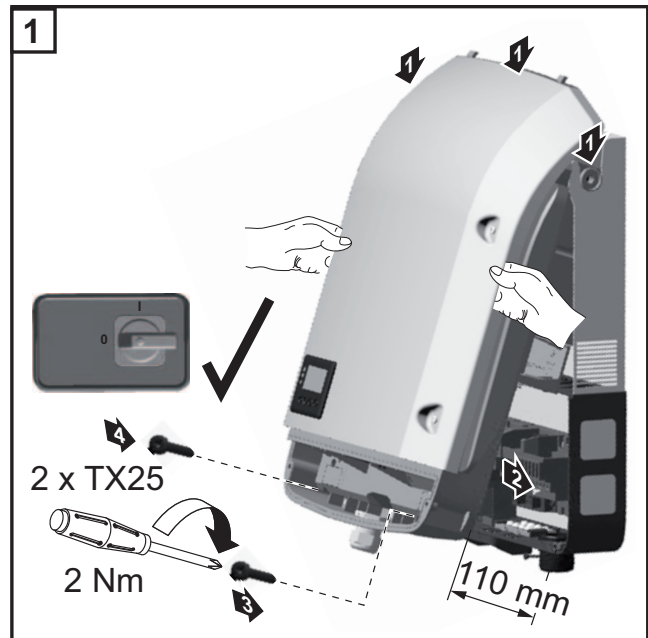
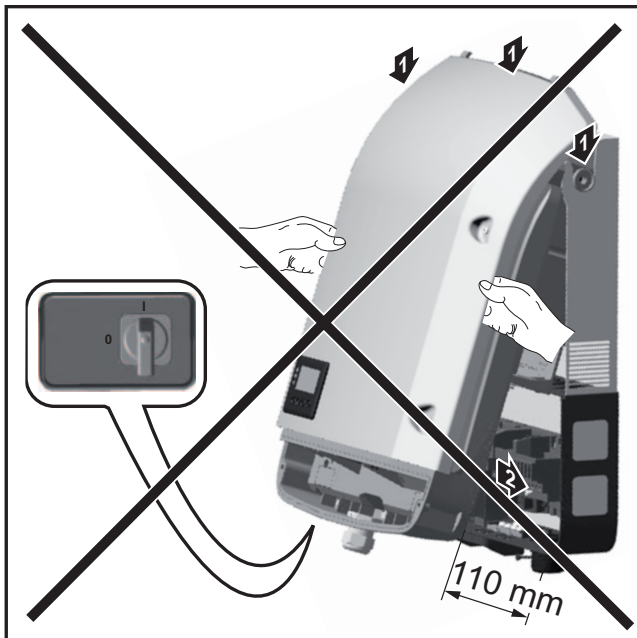

* Country Setups

DE1	Deutschland: Anlagengröße < 3,68 kVA
AT1	Österreich: Anlagengröße < 3,68 kVA
AT2	Österreich: Anlagengröße > 3,68 kVA und < 13,8 kVA
AT3	Österreich: Anlagengröße > 13,8 kVA
CH	Schweiz / Suisse / Svizzera / Svizra
GB	Great Britain
NL	Nederland
ES	España
FR	France
PT	Portugal
IE	Éire / Ireland; Malta
GR	Ελλάς
BE	Belgique / België
CZ	Česko
SK	Slovensko
TR	Türkiye

HU	Magyarország
DK	Danmark
SI	Slovenija
DE2	Deutschland: Anlagengröße > 3,68 kVA und < 13,8 kVA
DE3	Deutschland: Anlagengröße > 13,8 kVA
EX	Exchange
KR	남한, 南韓 (South Korea)
50HZ	International 50 Hz
MG50	Microgrid 50 Hz
MG60	Microgrid 60 Hz
TW	中華民國 (Taiwan)
FROS	Territoire d'Outre-Mer (French Oversea Islands)
ESOS	Territorios españoles en el extranjero (Spanish Oversea Islands)
IL	לישראל / لائى اسرائيل / לארשי תידימ / Israel
60HZ	International 60 Hz
AU	Australia
IT	Italia

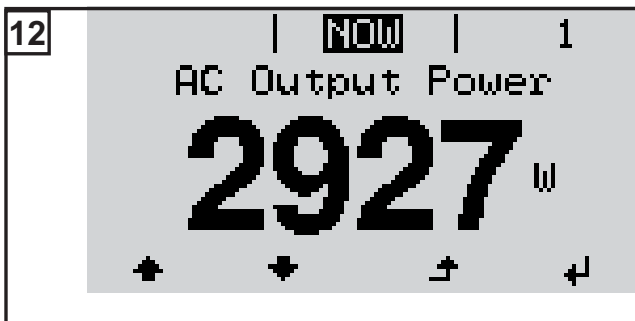
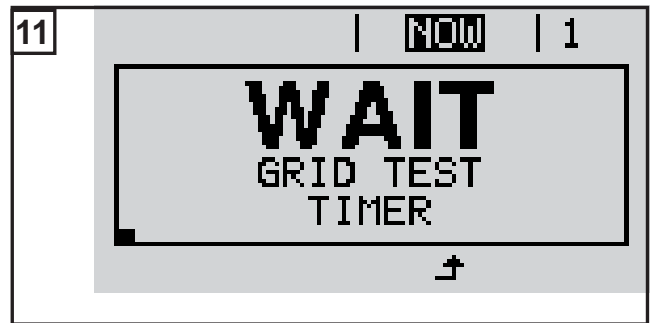
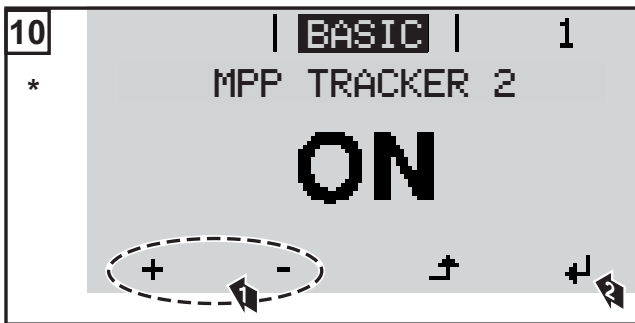
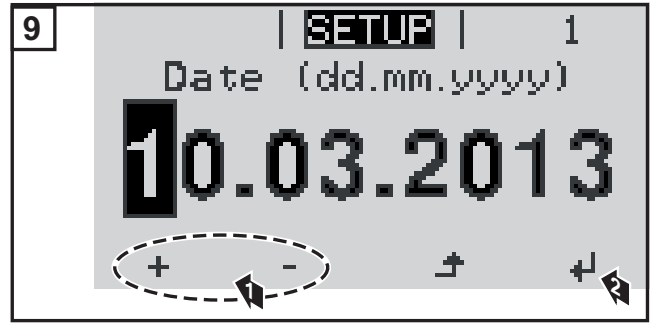
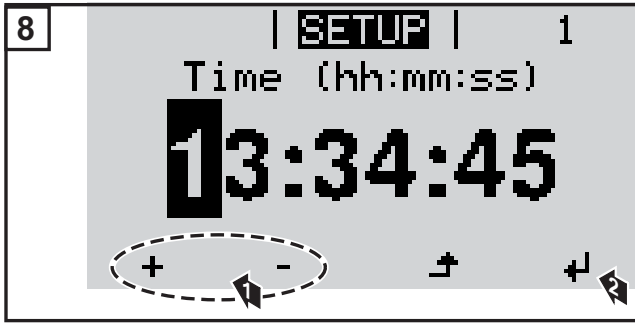

*

DE	Die Anzeige der einzustellenden Parameter hängt vom ausgewählten Gerätetyp ab
EN	The display of parameters to be configured depends on the selected device type
FR	L'affichage des paramètres à configurer dépend du type d'appareil sélectionné
ES	La indicación de los parámetros a ajustar varía en función del tipo de equipo seleccionado
IT	La visualizzazione dei parametri da impostare dipende dal modello di apparecchio selezionato
NL	De weergave van de in te stellen parameter hangt af van het geselecteerde type apparaat
DA	Parametrene, der skal indstilles, afhænger af den udvalgte apparattype
EL	Ç õñïãñß ðùí ðãñãíÝõñùí ðñìò ñýëíëóç áñãñõÙðáë áðu ðíí áðëëããíÝíí ðýðí ððóëãðßð
HU	A beállítandó paraméterek kijelzése a kiválasztott készüléktípustól függ
TR	Ayarlanacak parametrelerin göstergesi seçili cihaz tipine bağlıdır
CS	Zobrazení nastavovaných parametrů závisí na zvoleném typu přístroje
SK	Zobrazenie nastavovaných parametrov závisí od zvoleného nastavenia typu zariadenia
PT-BR	A exibição dos parâmetros a configurar depende do tipo de aparelho selecionado
SV	Indikeringen av de parametrar som ska ställas in är beroende av den valda typen av enhet.

FIRMWARE UPDATE

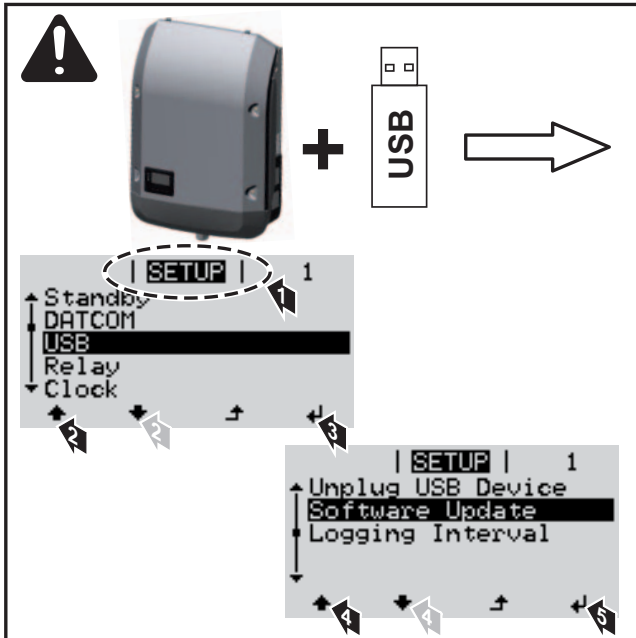

Fronius Worldwide - www.fronius.com/addresses

A **Fronius International GmbH**
4600 Wels, Froniusplatz 1, Austria
E-Mail: pv@fronius.com
<http://www.fronius.com>

USA **Fronius USA LLC** Solar Electronics Division
6797 Fronius Drive, Portage, IN 46368
E-Mail: pv-us@fronius.com
<http://www.fronius-usa.com>

Under <http://www.fronius.com/addresses> you will find all addresses of our sales branches and partner firms!