



Proven Performance™

K-Bar Industries, Faribault, MN 55021

M157471A

ITEM NUMBERS: 157471,
157472

Owner's Manual

Pressure Washer: Machine that cleans dirty surfaces with high pressure water.



⚠ WARNING

Read this manual.

Serious injury or death can result if safety instructions are not followed.

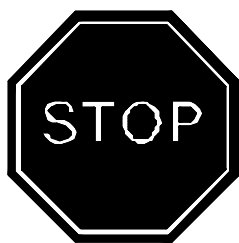

Engine is shipped without oil.

- Before starting engine, fill engine oil.
- See engine manual for engine oil requirements.

Closely inspect all components.

- If you have damaged components then: Contact the freight company that delivered the unit and file a claim.
- If you have missing components then: Contact Customer Service at 1-800-270-0810.

fig01912

Any Questions, Comments, Problems or Parts Orders

Call NorthStar Customer Service 1-800-270-0810

Hazard Signal Word Definitions





	<p>This is the safety alert symbol. It is used to alert you to potential personal injury hazards. Obey all safety messages that follow this symbol to avoid possible injury or death.</p>
	<p>DANGER (red) indicates an imminently hazardous situation which, if not avoided, will result in death or serious injury.</p>
	<p>WARNING (orange) indicates a potentially hazardous situation which, if not avoided, could result in death or serious injury.</p>
	<p>CAUTION (yellow) indicates a potentially hazardous situation which, if not avoided, may result in minor or moderate injury.</p>
	<p>CAUTION (yellow) used without the safety alert symbol indicates a potentially hazardous situation which, if not avoided, may result in property damage.</p>

fig01453

Table of Contents

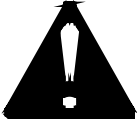
▲ Important Safety Rules.....	4-5
▲ Warning Label Locations.....	6
Unpacking.....	7
Machine Component Identification.....	8
Pump Component Identification.....	9
▲ Operation Instructions.....	10-13
Water Supply.....	10
Start-Up Instructions.....	10
Shut-Down Instructions.....	10
Spray Gun Safety Lock.....	11
Attaching the Pressure Hose.....	11
Attaching the Lance.....	12
Operating the Nozzle.....	12
Applying Chemicals.....	13
▲ Maintenance.....	14-15
Maintenance Mode.....	14
Maintenance Schedule.....	14
Cleaning/Replacing the Nozzle Orifice.....	14
Engine Oil Change.....	15
▲ Storage.....	15
Long Term Storage.....	15
Winter Storage.....	15
Troubleshooting	16
Specifications and Accessories.....	16
Parts Explosion	17

▲ Important Safety Rules





▲ WARNING	
	<p>1.) Read owner's manual completely. Serious injury or death can result if safety instructions are not followed. You must be 16 or older to operate this machine. Keep untrained people away.</p>
	<p>2.) Skin puncture hazard. High pressure fluid can inject under skin resulting in serious injury including amputation. Do not direct spray at people or animals. -If skin injection happens, seek IMMEDIATE surgical treatment. -Do not check for leaks with hand. Instead, use a piece of cardboard to check for leaks. -Do not use unit if exterior hose damage is evident. Make sure all fittings are tight before starting. Relieve system pressure before servicing. -Know how to stop engine and bleed pressures quickly. Be thoroughly familiar with the controls. -Make sure accessories meet the unit's temperature and pressure limits. -Stop engine, bleed pressure, and engage spray gun safety lock before leaving unit unattended.</p>
 	<p>3.) Risk of fire and explosion. Hot exhaust fumes from engine can cause fire. Gasoline is highly flammable and explosive. You can be burned or seriously injured when handling fuel. -Position muffler at least 7 feet from combustible objects. -Before adding fuel, stop the engine and keep heat, sparks, and flame away. Do not add fuel when engine is running or still hot. No smoking near engine. -Do not pump fuel directly into engine at gas station. Static charge can build and ignite fuel. Use a UL approved fuel container to transfer gas to the engine. Wipe up fuel spills immediately. -Only store and handle fuel outdoors. Gasoline vapors can ignite if they collect inside an enclosure. Explosion can result. -Do not change or add to exhaust system. Fire can result. -Do not change or add fuel tanks or fuel lines. Fire can result. -Before each use, check fuel tank and fuel lines for leaks. Any fuel leak is a fire hazard. Fix any fuel leaks before starting engine. -During transportation take precautions to make sure pressure washer will not tip over and cause a fuel leak fire hazard.</p>
	<p>4.) Poisonous gas. This machine gives off carbon monoxide, a poisonous gas that can kill you. You CANNOT smell it, see it, or taste it. -ONLY run machine outdoors and away from air intakes. -NEVER run machine inside homes, garages, sheds, or other semi-enclosed spaces. These spaces can trap poisonous gases, EVEN IF you run a fan or open doors and windows. If you start to feel sick, dizzy, or weak while using this machine, shut it off and get to fresh air RIGHT AWAY. See a doctor. You may have carbon monoxide poisoning.</p>

fig01372

Save These Instructions

▲ Important Safety Rules

▲ WARNING

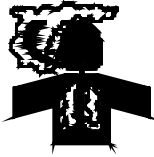
5.) Risk of exposure to dangerous chemicals.

Serious injury or death can result if chemical manufacturer instructions are not followed.

- Wear protective gloves when handling and cleaning with chemicals.
- Understand all safety hazards and first aid for all chemicals being used.
- When cleaning filters, check if chemicals have been used and take any precautions that are recommended by the chemical manufacturer.
- Different chemicals may interact dangerously with each other, always follow chemical manufacturer directions before switching chemicals.
- Calculate the correct amount of chemical to mix, dispose of excess chemical per the manufacturer instructions.
- Never spray flammable liquids.

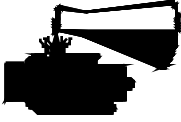

6.) Risk of electrocution.

Electricity can kill you. Keep water away from electrical outlets and electrical devices.



7.) Flying objects.

Small particles may fly out while spraying. Wear safety glasses. Serious eye injury can occur.

Make sure nozzle is secure before squeezing trigger. If nozzle is not secure it will become a projectile.



8.) Fall hazard.

Pressure washer creates puddles and slippery surfaces. Keep good footing and balance. Serious injury can occur.

- Wear footwear capable of maintaining a good grip on wet surfaces.
- Gun kicks back. Hold with both hands.
- Do not overreach or stand on unstable supports.
- Do not stand on ladders or scaffolding.
- Do not place pressure washer on soft or unstable ground.



▲ CAUTION

1.) Hot muffler.

You can be burned by muffler. Do not touch.



fig01046

Save These Instructions





▲ Warning Label Locations

Call 1-800-270-0810 to order new labels.

Instruction Label: Part No. 32538

Warning Label: Part No. 38570

▲ WARNING

	<p>1.) Skin puncture hazard. Do not direct spray at people or animals. Seek IMMEDIATE surgical treatment.</p>
	<p>2.) Risk of fire and explosion. Do not add fuel when engine is running or still hot.</p>
	<p>3.) Breathing hazard. Poisonous fumes from engine can kill you. Do not operate indoors even if ventilated.</p>
	<p>4.) Risk of electrocution. Keep water away from electric outlets and electric devices.</p>
	<p>5.) Read owner's manual. Serious injury or death can result if safety instructions are not followed.</p>

©2003 K-Bar Industries 800-270-0810 Part No. 38570

<p><u>START-UP INSTRUCTIONS</u></p> <ol style="list-style-type: none"> 1. Attach garden hose. 2. Attach pressure hose. 3. Attach gun and lance. 4. Turn water supply ON. 5. Squeeze trigger to purge air from pump. 6. Insert nozzle. 7. Start engine. 	<p><u>SHUT-DOWN INSTRUCTIONS</u></p> <ol style="list-style-type: none"> 1. Turn engine OFF. 2. Turn water supply OFF. 3. Squeeze trigger to relieve system pressure. 4. Remove garden hose. 5. Remove pressure hose. 6. Turn fuel valve OFF (if equipped).
---	--



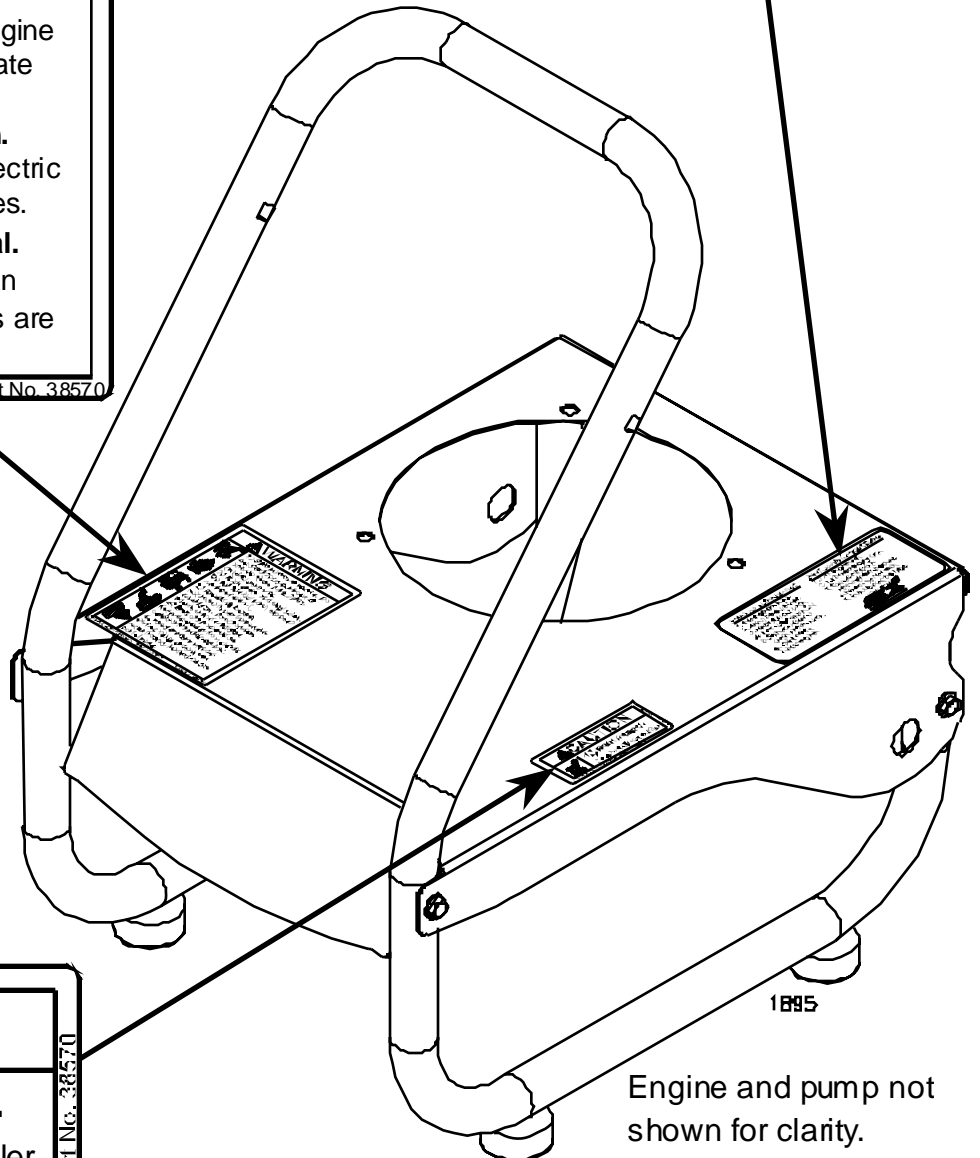

▲ CAUTION

	<p>1.) Burn hazard. Do not touch hot muffler.</p>
---	--

©2003 K-Bar Industries 800-270-0810 Part No. 38570

Engine and pump not shown for clarity.

Unpacking

-Separate and identify the components.

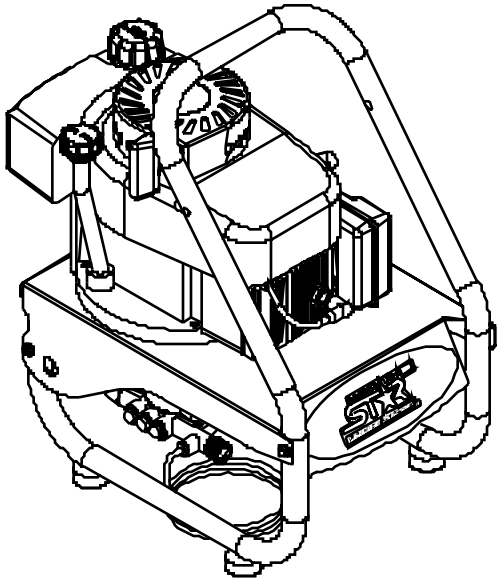

Pressure Washer

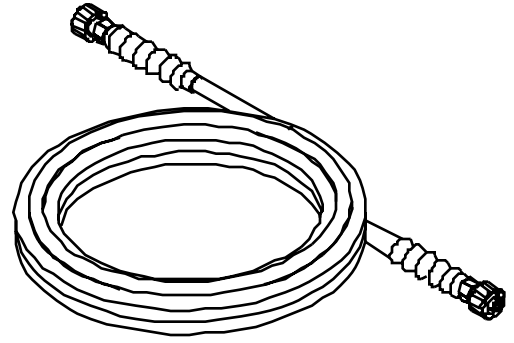

Pressure Hose

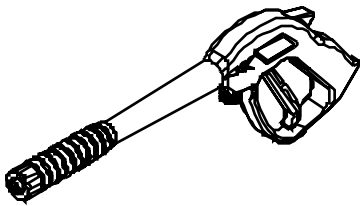

Spray Gun

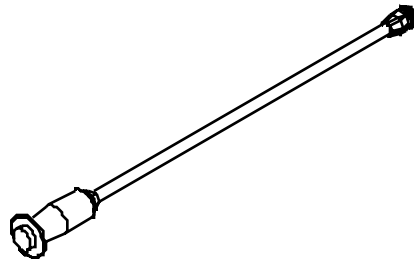

Lance

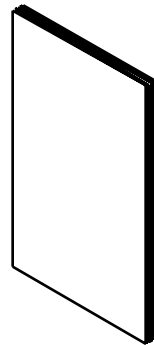

Owner's Manual

01894

Any Questions, Comments, Problems or Parts Orders

Call NorthStar Customer Service 1-800-270-0810

Machine Component Identification

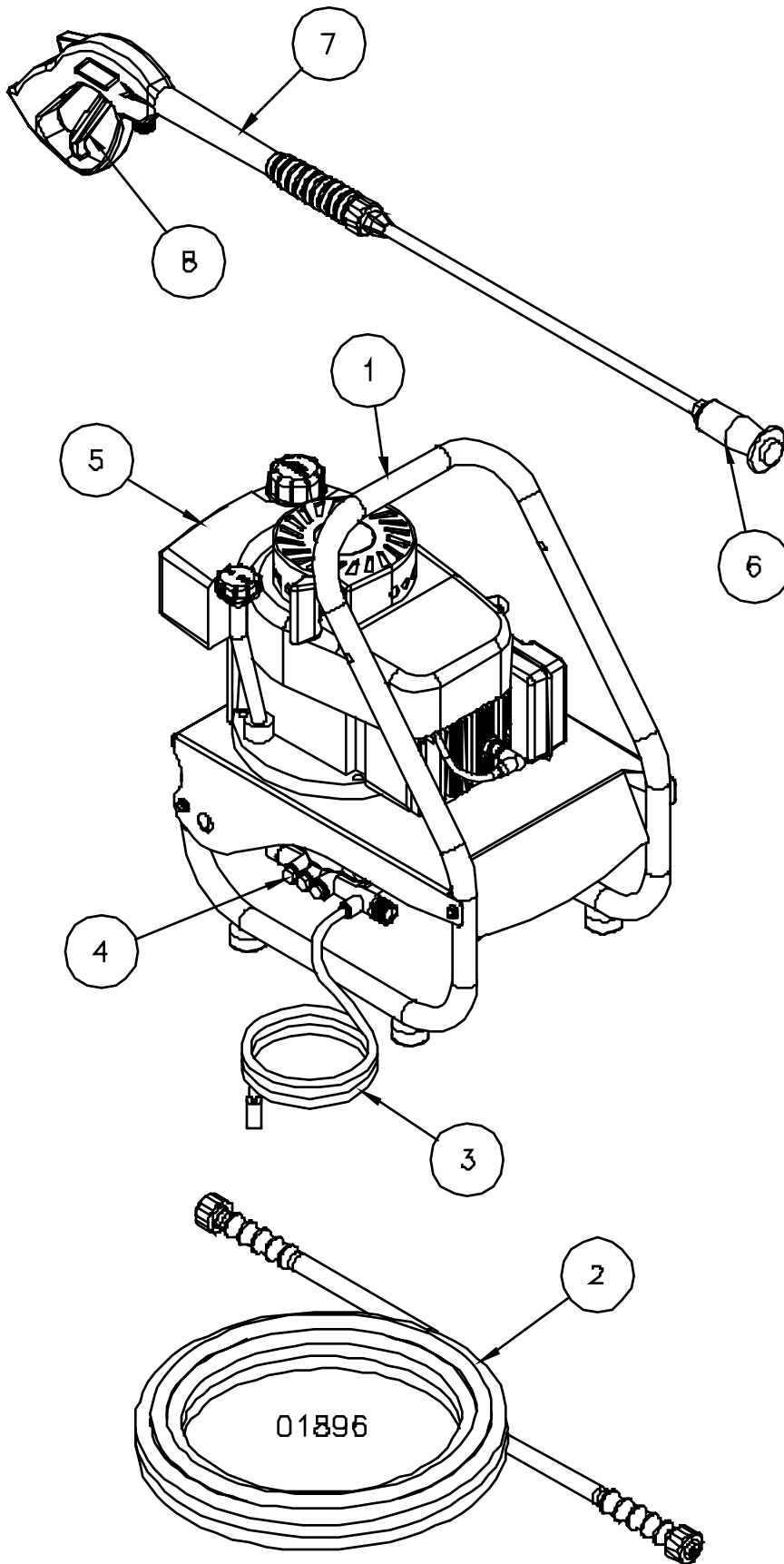

- 1.) Carry Handle
- 2.) Pressure Hose
- 3.) Chemical Hose
- 4.) Water Pump
- 5.) Engine
- 6.) Nozzle
- 7.) Spray Gun
- 8.) Trigger

Pump Component Identification

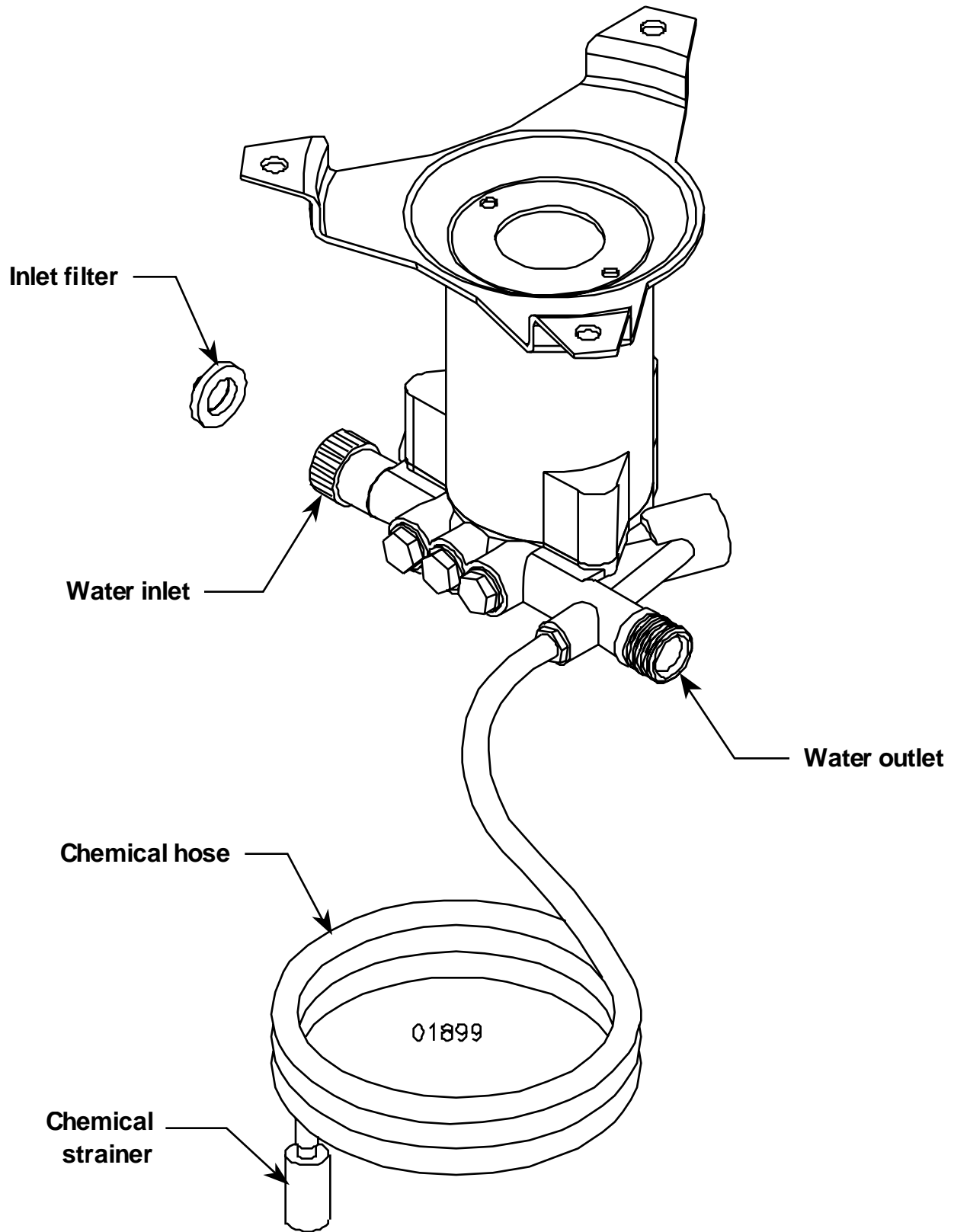

▲ Operation Instructions

Water Supply

- 1.) Make sure water supply is clean. Debris can cause excess pump wear and reduce performance.
- 2.) An insufficient water supply will damage your pump. Make sure the water supply is steady and is 20% over the rated flow of your pump. Use a stopwatch to time how long it takes to fill a 5 gallon bucket with your garden hose. The bucket must be filled in less than 125 seconds.
- 3.) The water supply garden hose must have an inside diameter of at least 5/8". If the hose is more than 100 ft. long, the diameter must be at least 3/4".
- 4.) Never use a reservoir tank as a water source. Drawing water out of a tank may cause pump cavitation and damage to your pump. This pressure washer is designed for a pressurized water source such as a city water faucet. However, the water source pressure must not exceed 115 psi (8 bar).
- 5.) Always use a flexible rubber hose for your water supply. Do not use rigid piping.

Start-Up Instructions

- 1.) Attach garden hose to water inlet.
- 2.) Attach pressure hose to water outlet and spray gun.
- 3.) Attach spray gun to lance.
- 4.) Turn water supply ON.
- 5.) Squeeze trigger to purge air from water pump.
- 6.) Start engine.

Shut-Down Instructions

- 1.) Turn engine OFF.
- 2.) Turn water supply OFF.
- 3.) Squeeze trigger to relieve system pressure.
- 4.) Remove garden hose.
- 5.) Remove pressure hose.

	<h2>▲ WARNING</h2>
	<p>Skin puncture hazard.</p> <p>High pressure fluid can inject under skin resulting in serious injury including amputation. Do not direct spray at people or animals.</p> <ul style="list-style-type: none">-If skin injection happens, seek IMMEDIATE surgical treatment.-Do not check for leaks with hand. Instead, use a piece of cardboard to check for leaks.-Do not use unit if exterior hose damage is evident. Make sure all fittings are tight before starting. Relieve system pressure before servicing.-Know how to stop engine and bleed pressures quickly. Be thoroughly familiar with the controls.-Make sure accessories meet the unit's temperature and pressure limits.-Stop engine and bleed pressures before leaving unit unattended.

fig 01 003

▲ Operation Instructions

Spray Gun Safety Lock

When not spraying, use the spray gun safety lock to prevent accidental high pressure discharge.

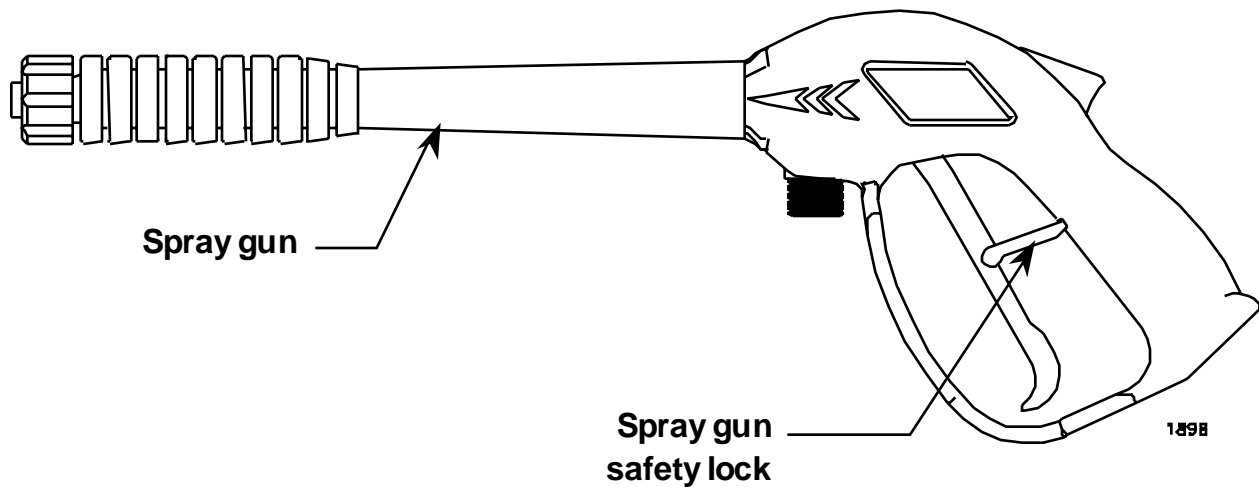

Attaching the Pressure Hose

- To attach the pressure hose to the pump, thread the pressure hose's 22mm coupler onto the water pump's outlet hand tight.
- To attach the pressure hose to the spray gun, thread the pressure hose's 22mm coupler onto the spray gun's inlet hand tight.
- Note: The o-rings make the seal so there is no need to tighten with a wrench.

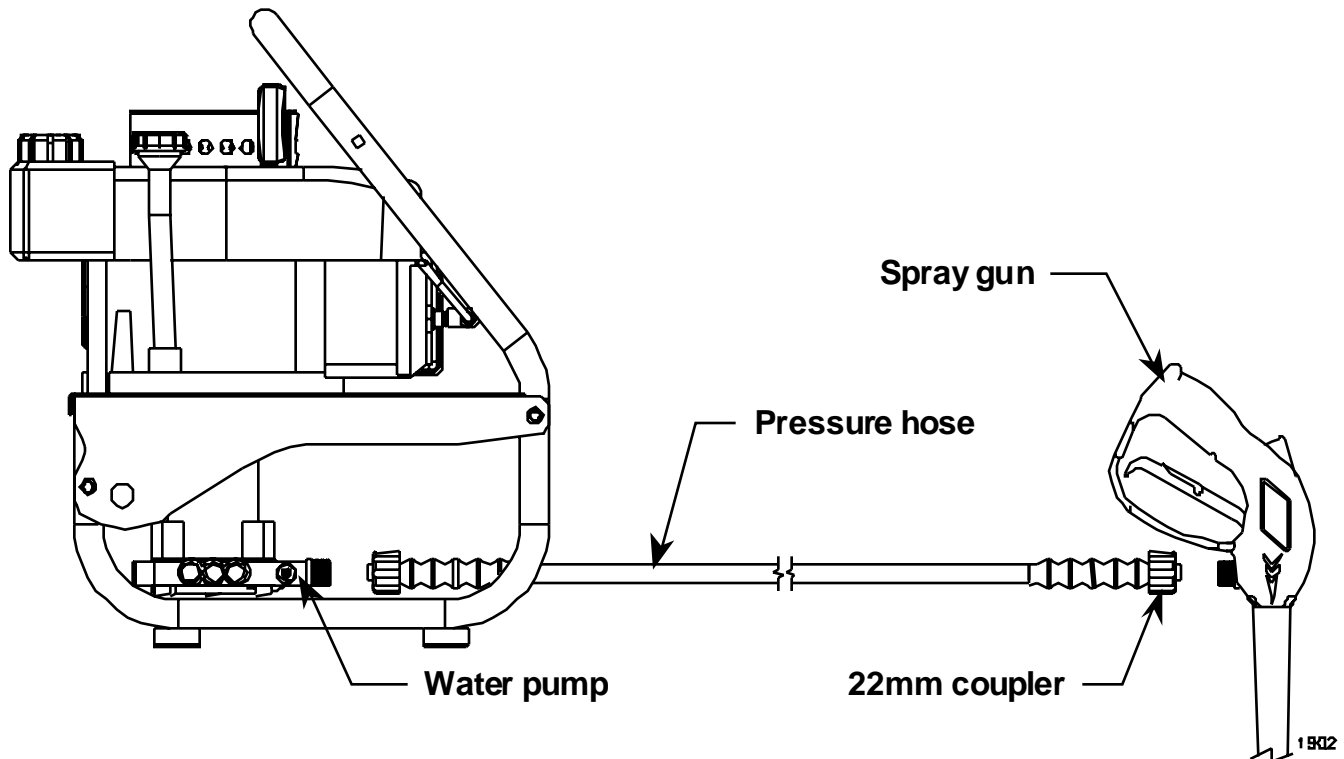

▲ Operation Instructions

Attaching the Lance

Tighten spin-on coupler hand tight.

Note: The o-rings make the seal so there is no need to tighten with a wrench.

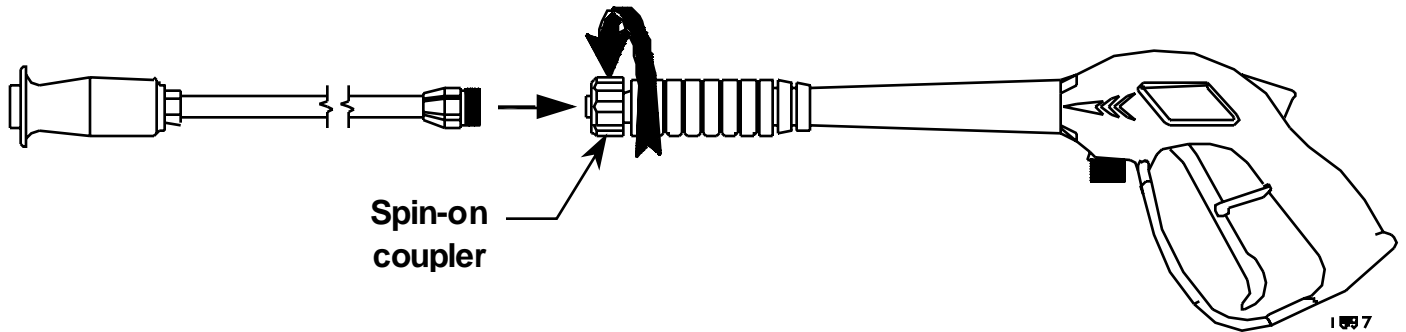

Operating the Nozzle

-Twist the nozzle to change the spray pattern from a straight stream to a 45° fan.

-Pull the nozzle back for high pressure; push the nozzle forward for low pressure.

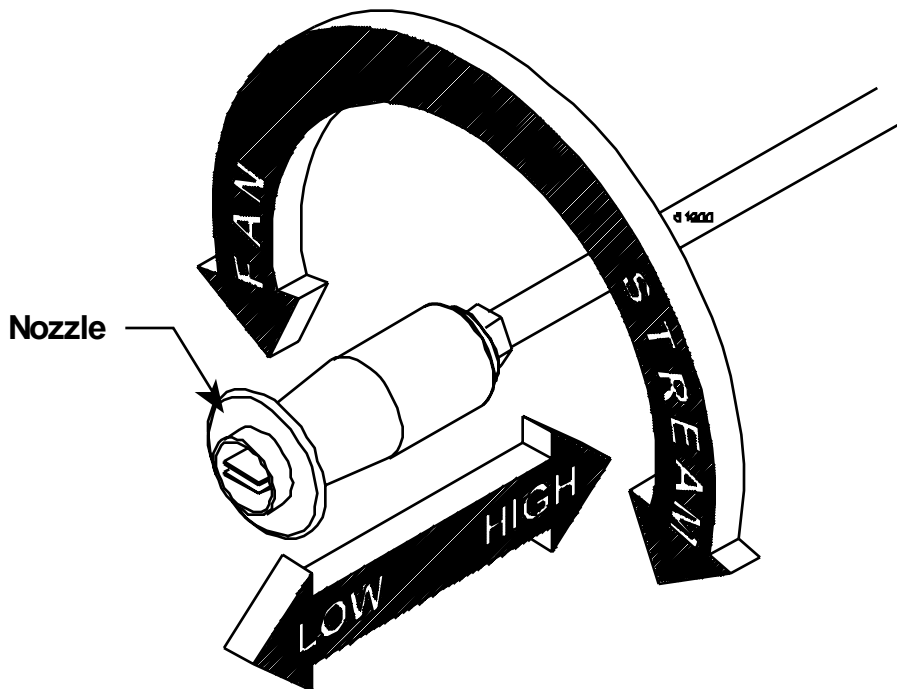

▲WARNING	
	Skin injection hazard.
	-High pressure fluid can inject under skin resulting in serious injury including amputation.
	-Make sure all fittings are tight before applying pressure. Relieve system pressure before servicing.
	-Do not check for leaks with hand. Instead, use a piece of cardboard to check for leaks.
	-If skin injection happens, seek immediate "Surgical Treatment".

▲ Operation Instructions

Applying Chemicals

- 1.) Push the nozzle forward for low pressure to spray chemicals onto the cleaning surface.
- 2.) Start the pressure washer according to the start-up instructions.
- 3.) Submerge the chemical hose and chemical strainer in cleaning solution.
- 4.) Squeeze the spray gun trigger. The chemical injector will draw the cleaning solution into the water stream.
- 5.) Apply chemicals evenly onto the cleaning surface. Allow the chemicals to react with the dirt, then clean at high pressure by pulling the nozzle backward.
- 6.) Never use more chemical than is necessary to clean the surface.
- 7.) Rinse chemical injector by following steps 1 through 4 with clean water.

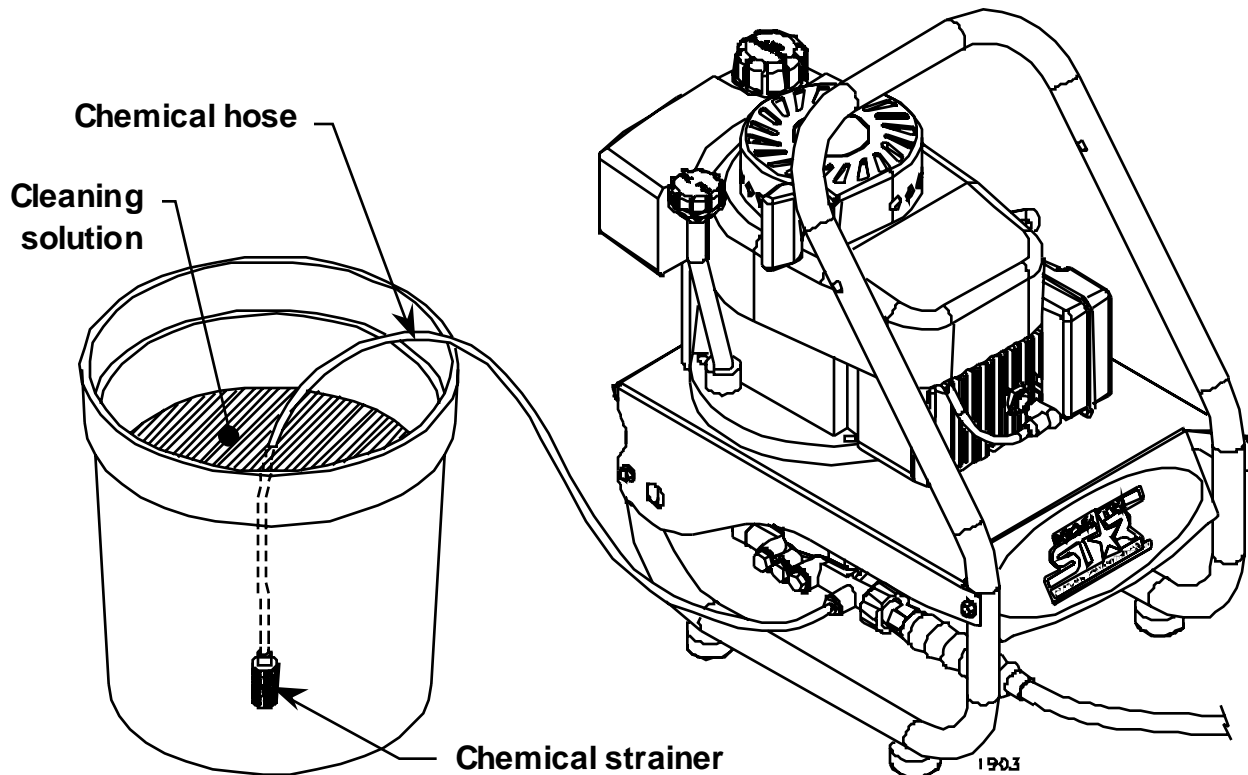

▲ WARNING

Risk of exposure to dangerous chemicals.

Serious injury or death can result if chemical manufacturer instructions are not followed.

- Wear protective gloves when handling and cleaning with chemicals.
- Understand all safety hazards and first aid for all chemicals being used.
- When cleaning filters, check if chemicals have been used and take any precautions that are recommended by the chemical manufacturer.
- Different chemicals may interact dangerously with each other, always follow chemical manufacturer directions before switching chemicals.
- Calculate the correct amount of chemical to mix, dispose of excess chemical per the manufacturer instructions.
- Never spray flammable liquids.



T-0124 E

▲ Maintenance

Maintenance Mode

Before performing any maintenance on the pressure washer, it must be placed in maintenance mode.

- 1.) Turn off engine.
- 2.) Turn off water supply.
- 3.) Squeeze trigger to relieve system pressure.
- 4.) Unplug spark plug wire from spark plug. (see engine owner's manual)

Maintenance Schedule

What to Check	When To Check	What to Do
Inlet Filter	Each Use	Visually inspect and clean inlet filter with clear water.
Pressure Hose	Each Use	Visually inspect pressure hose and hose couplings. Replace hose if any of the following is evident: hose coupling is damaged, wire mesh is exposed or damaged, hose is permanently kinked or flattened, outer hose cover is blistered or loose.
Bolts	Each Use	Tighten any loose bolts.
Engine Oil	See engine manual	See engine manual for oil change intervals, see Maintenance section of this manual for oil change instructions.
Pump Oil	Never	The pump's crankcase is sealed; oil changes are not required.

Cleaning/Replacing the Nozzle Orifice

- 1.) Place pressure washer in maintenance mode. (see above)
- 2.) Insert a 2mm hex wrench into orifice and turn counter-clockwise to remove orifice from nozzle.
 - To clean orifice, remove any debris and soak in descaling solution to remove hard water deposits.
 - To replace orifice, order p/n PD38780 from NorthStar Customer Service, 1-800-270-0810
- 3.) Use 2mm hex wrench and turn clockwise to reinstall orifice.

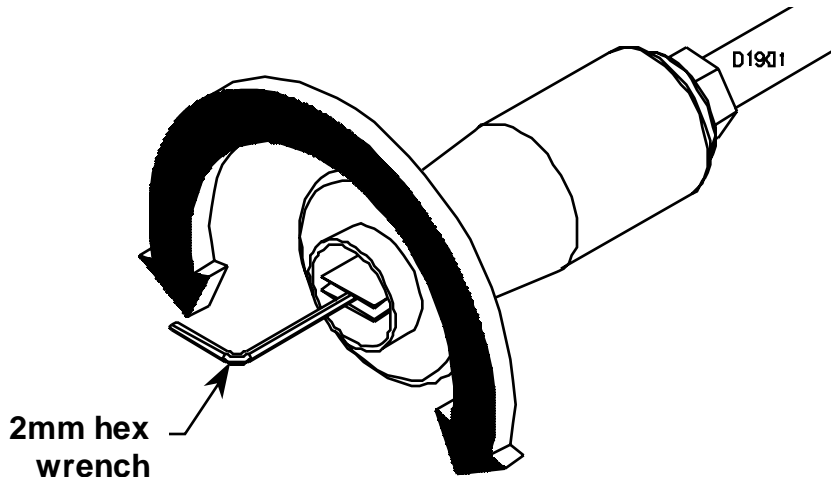

	<h2 style="margin: 0;">▲ WARNING</h2>
	<p>Skin injection hazard.</p> <p>High pressure fluid can inject under skin resulting in serious injury including amputation.</p> <ul style="list-style-type: none"> -Make sure all fittings are tight before applying pressure. Relieve system pressure before servicing. -Do not check for leaks with hand. Instead, use a piece of cardboard to check for leaks. -If skin injection happens, seek immediate "Surgical Treatment".

▲ Maintenance

Engine Oil Change

- 1.) Place a suitable container on the ground to catch the used oil, then remove the engine oil fill cap.
- 2.) Tip the pressure washer on its side to pour the used oil out through the engine's oil fill tube.
- 3.) Please dispose of used oil in a manner that is compatible with the environment. We suggest you take used oil in a sealed container to your local recycling center or service station for reclamation. Do not throw it in the trash, pour it on the ground, or dump it down the drain.
- 4.) With the pressure washer in a level position, add oil to the engine. (see engine owner's manual for type of oil and capacity)

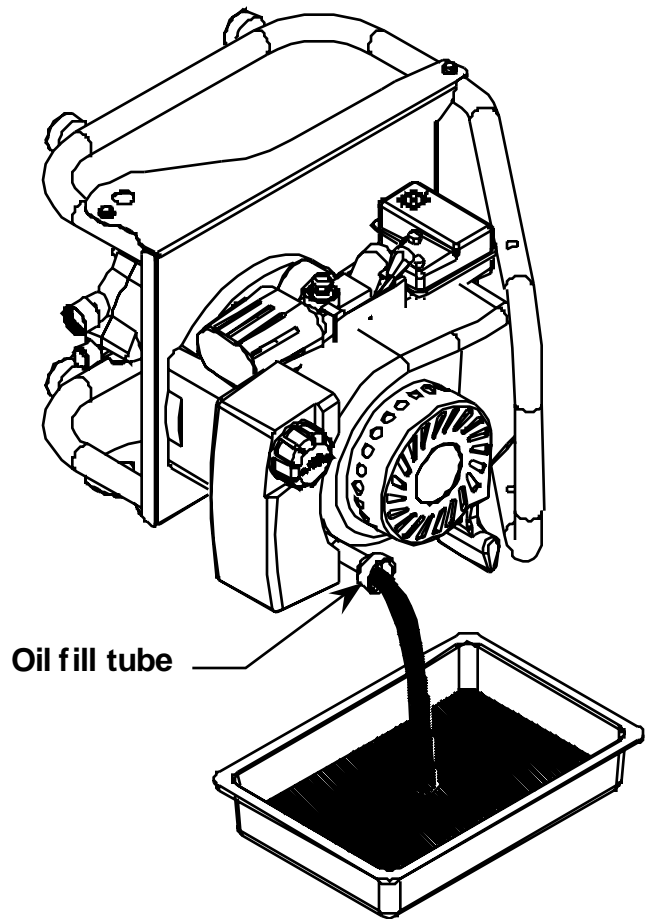

▲ Storage

Long Term Storage

Follow the engine owner's manual for storing the engine.

Winter Storage

Protect your pump, hose, and gun from freezing. Items needed: 12" piece of garden hose or equivalent, funnel and RV antifreeze (approximately 6 oz.)

- 1.) Follow the storage instructions listed above.
- 2.) Disconnect spark plug cable. Make sure the engine throttle lever is in the "stop" position.
- 3.) Attach the garden hose with funnel to the water inlet (see illustration).
- 4.) Pour RV antifreeze into the funnel; pull the engine recoil until antifreeze comes out of the water outlet.
- 5.) Drain all water from the pressure hose. Depress trigger on spray gun to drain all water out of the spray gun/lance.

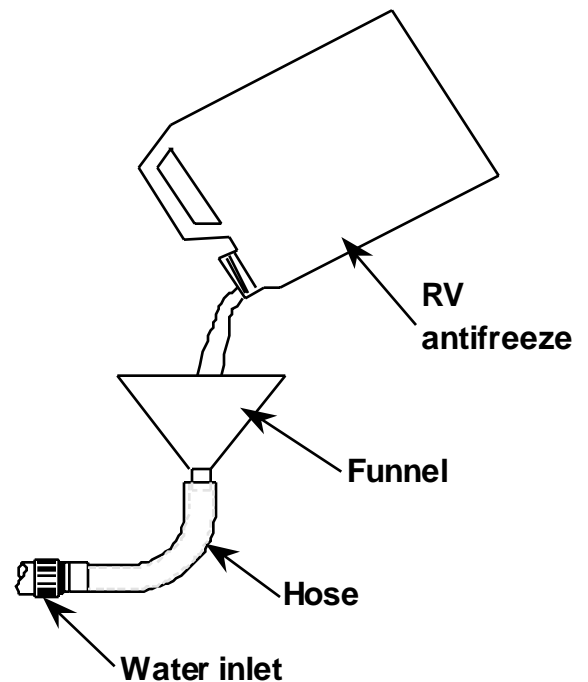

Troubleshooting

Problem	
Engine will not start	SOLUTION: A
Low/Surging pressure or no water flow	SOLUTION: B,C,D,E,F,G
No chemical injection	SOLUTION: H,I,J,K
Cause	Solution
A- Engine starting instructions not followed	See engine manual for starting instructions
B- Insufficient water supply	See water supply section of this manual
C- Plugged pump inlet filter	See maintenance section of this manual
D- Nozzle in low pressure position	Pull nozzle back for high pressure
E- Plugged nozzle orifice	Remove nozzle orifice, check for blockage
F- Worn nozzle orifice	Replace nozzle orifice
G- Leak in pressure hose	Replace pressure hose
H- Nozzle in high pressure position	Push nozzle forward for low pressure
I- Back pressure from extra long pressure hose	Use standard length hose
J- Leak in chemical siphon hose	Replace hose – use hose clamps if necessary
K- Chemical strainer not submerged	Make sure strainer is completely submerged

Specifications and Accessories

Specifications

157471	
PSI	2000
GPM	2.0
Max Water Temp	140°F
Dimensions (inches) L x W x H	16.75 x 13.5 x 19.75
Weight	50 lbs

157472	
PSI	2400
GPM	2.0
Max Water Temp	140°F
Dimensions (inches) L x W x H	16.75 x 13.5 x 19.75
Weight	52 lbs

Accessories

Wheel kit, Item# 157473	Call Northern Tool & Equipment, 1-800-556-7885
-------------------------	--

The manufacturer reserves the right to make improvements in design and/or changes in specifications at any time without incurring any obligation to install them on units previously sold.

Any Questions, Comments, Problems or Parts Orders

Call Northstar Customer Service 1-800-270-0810

Parts Explosion

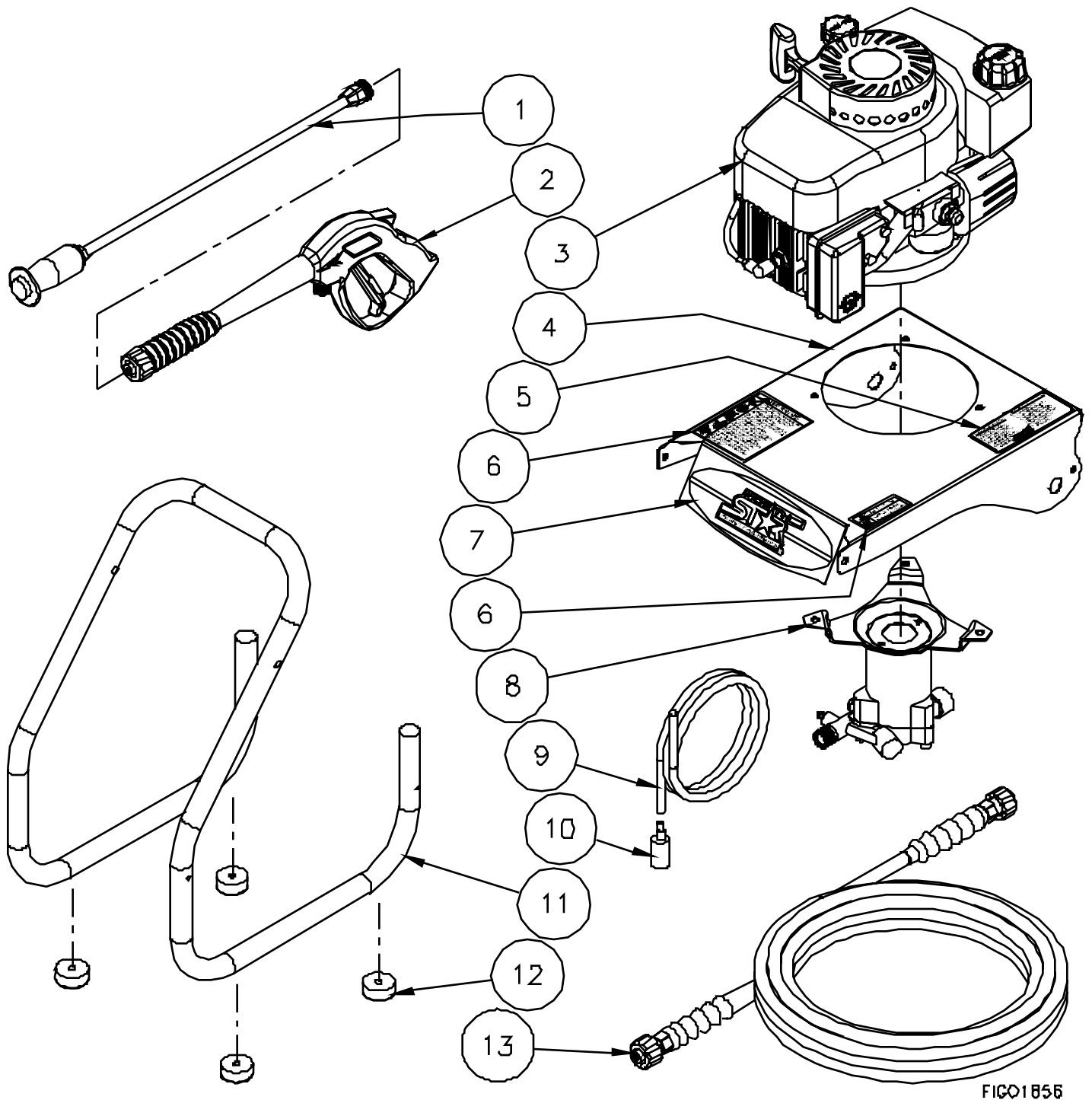

FIG01855

Item	Part#	Description	Qty	Model
1	38528	Lance	1	all
2	38526	Spray gun	1	all
3	38488	Engine, 4HP Tecumseh	1	157471
	37442	Engine, 6HP Tecumseh	1	157472
4	38506	Base	1	all
5	32538	Instruction decal	1	all
6	38570	Warning decal sheet	1	all
7	38541	NorthStar decal	1	all

Item	Part#	Description	Qty	Model
8	38512	Water pump, VRX2017V	1	157471
	38513	Water pump, VRX2022V	1	157472
9	33488	Chemical hose	3ft	all
10	2212	Chemical strainer	1	all
11	38505	Carry handle	1	all
12	2215	Rubber feet	4	all
13	38523	Pressure hose	1	all