

INSTRUCTIONS-PARTS LIST



307-308

Rev. "B" 9-78
SUPERSEDES 1-78

This manual contains **IMPORTANT WARNINGS** and **INSTRUCTIONS**
READ AND RETAIN FOR REFERENCE

HYDRA-CLEAN® 1007

MODEL 226-813 SERIES "A"

Includes Hose and Gun Kit and
Chemical Injector Kit for injecting
cleaning chemicals downstream
from pump.

1000 PSI (70 bar) OPERATING PRESSURE

1200 PSI (83 bar) MAXIMUM WORKING PRESSURE

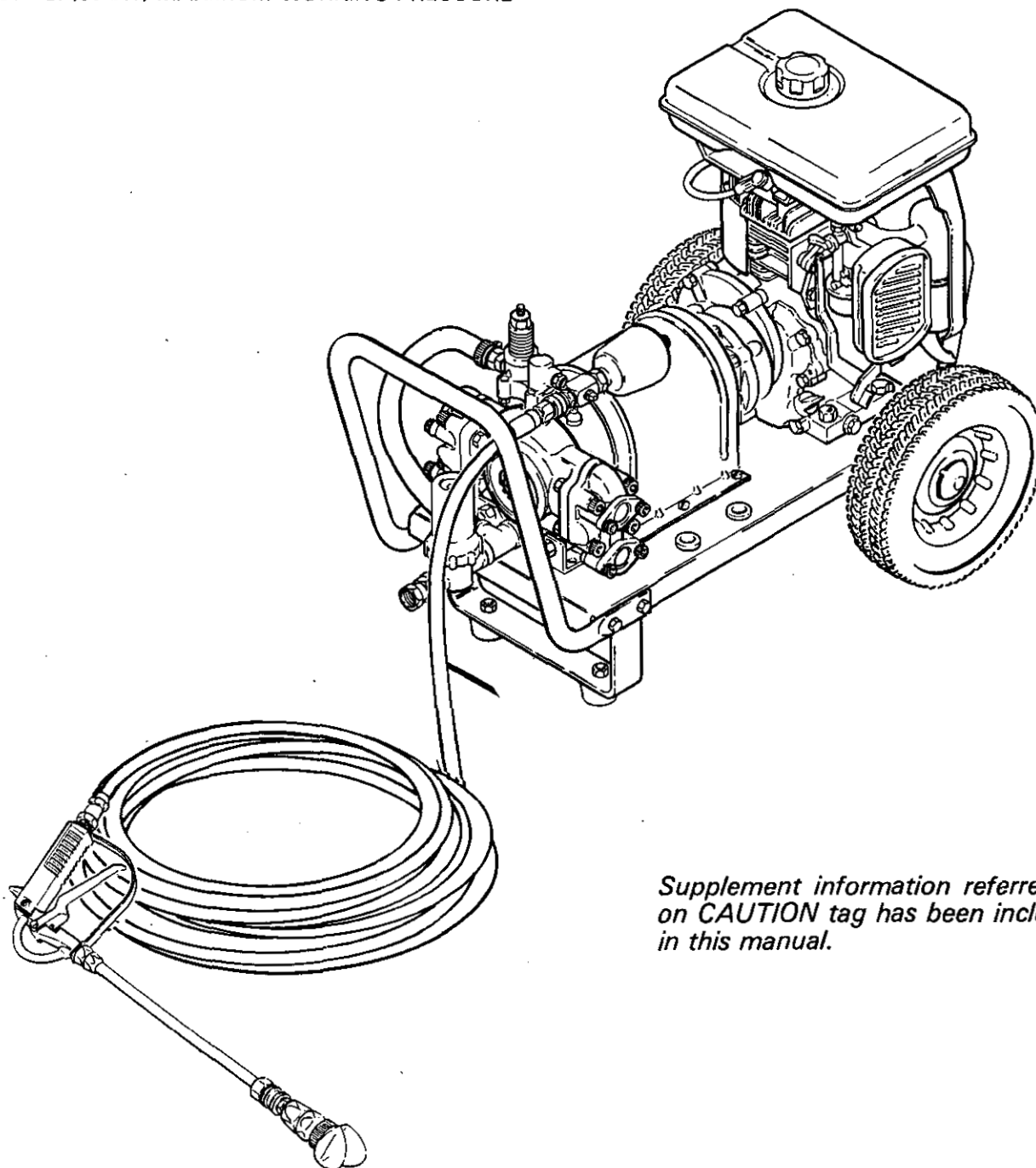

*Supplement information referred to
on CAUTION tag has been included
in this manual.*

GRACO INC. P.O. BOX 1441 MINNEAPOLIS, MN 55440

© COPYRIGHT 1978 GRACO INC.

WARNING

HIGH PRESSURE SPRAY CAN CAUSE SERIOUS INJURY

READ THESE WARNINGS BEFORE USING

KEEP AWAY FROM SPRAY

Because of the high pressure and velocity of the spray, fluids could penetrate the skin, causing serious injury. Operate equipment only after all instructions are clearly understood.

NEVER point the gun at yourself or anyone else. NEVER put your hand, fingers or body directly over the spray tip.

Even after you shut off the gasoline engine, there is high pressure in the pump, hose and gun until you release it by triggering the gun. So before removing the spray tip or servicing the unit, *always* shut off the unit *and* trigger the gun to release pressure.

If the spray appears to have penetrated the skin. **SEEK EMERGENCY MEDICAL CARE. DO NOT TREAT AS A SIMPLE CUT.** Be ready to tell the doctor exactly what fluid was injected.

Be sure that all accessory items and system components will withstand the pressure developed. *NEVER* exceed the pressure rating of any component in system. *NEVER* alter or modify equipment — your personal safety, as well as the function of the equipment, is at stake.

Before each use, check hose for weak, worn or damaged conditions caused by traffic, sharp corners, pinching or kinking. Tighten all fluid connections securely before each use. Replace any damaged hose.

Do not use chemicals or agents which are compatible with Buna-N and Buna-N/PVC or neoprene cover of hose.

Do not leave a pressurized unit unattended. Shut off the unit and release pressure before leaving.

FIRE

Do not spray flammable liquids. Do not operate the engine where combustible fumes or dust may be present.

GAS ENGINE PRECAUTIONS

NEVER fill fuel tank while engine is running or hot. Avoid the possibility of spilled fuel causing a fire. Always refuel slowly to avoid spillage.

NEVER operate engine in a closed building unless the exhaust is piped outside. The exhaust contains carbon monoxide, a poisonous, odorless and invisible gas, which if breathed causes serious illness and possible death.

NEVER make adjustments on machinery while it is connected to the engine; first remove the ignition cable from the spark plug. Turning over the machinery by hand during adjusting or cleaning might start the engine and machinery, causing serious injury to the operator.

NEVER run the engine with governor disconnected, or operate at speeds in excess of 3300 RPM load.

Precaution is the best insurance against an accident. When starting the engine, maintain a safe distance from moving parts of the equipment.

GENERAL

NEVER run unit with coupling shield or pump cover plate removed. Keep clear of moving parts when unit is running.

Observe detergent manufacturer's safety precautions. Avoid getting detergent or other liquids in your eyes. Follow the directions on the container regarding contact with eyes, nose, and skin, breathing fumes, etc. Always wear full goggles to protect your eyes from the spray as well as any debris dislodged by the spray. If necessary, wear gloves or other protective clothing. If antidotes or treatment are recommended, be prepared to use them.

DON'T spray toxic chemicals such as insecticide or weed killer.

IMPORTANT

United States Government safety standards have been adopted under the Occupational Safety and Health Act. These standards — particularly the General Standards, Part 1910, and the Construction Standards, Part 1926 — should be consulted in connection with your use of airless spray equipment.

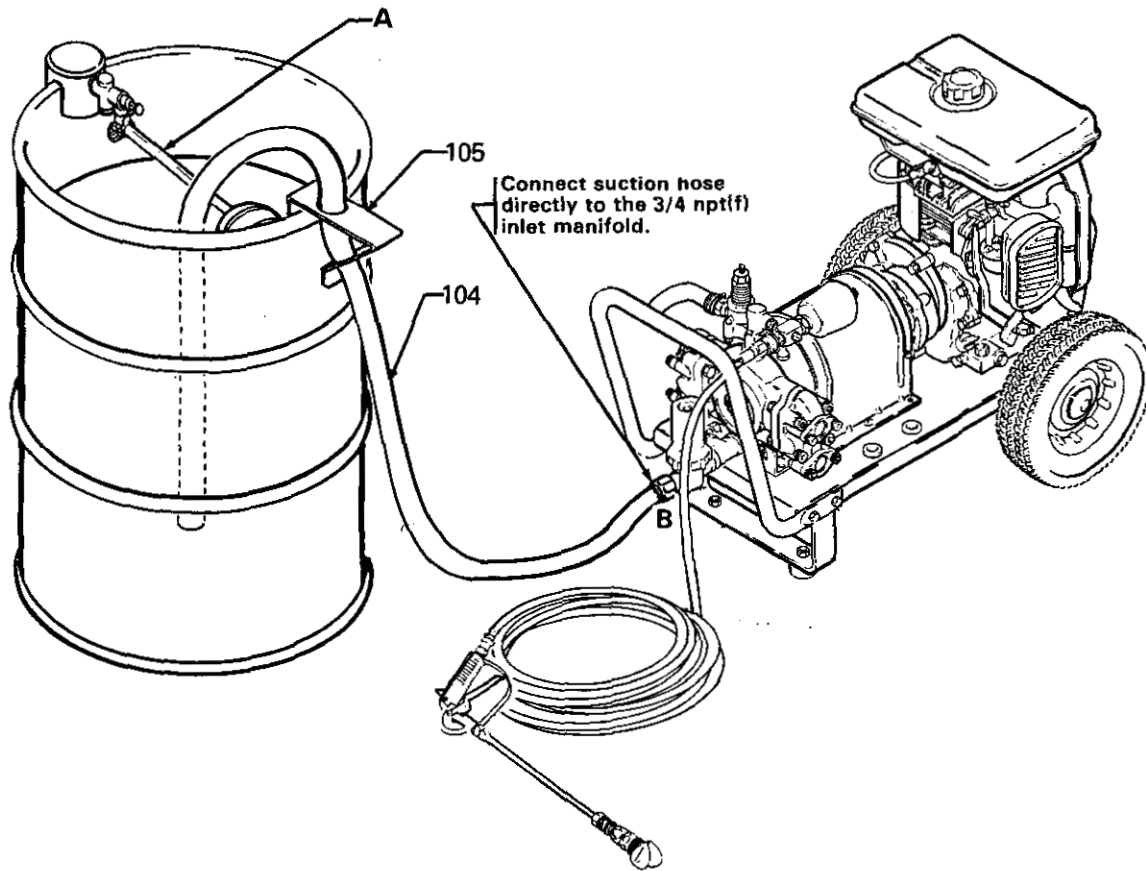

Fig 1

NOTE: Reference numbers and letters in parentheses in the text refer to Figures 1, 3, 4 and the Parts Drawing.

Refer to the engine instruction booklet provided with the unit.

Prepare The Cleaning Solution

Prepare and use cleaning solution according to manufacturer's instructions.

For spraying detergent or other cleaning solution, we recommend using a chemical injector kit. See instruction manual 307-325 for installation and operation.

Install Hose and Spray Gun

Assemble the spray gun, extension tube and nozzle valve and connect the spray gun to the hose. See manual 307-309 for details.

If a longer spray hose is required, 1/2 in. ID (12 mm) hose may be added at unit to a maximum overall hose length of 150 ft. (45 m).

Connect To Water Supply

CAUTION

Before attaching to water supply, check local plumbing code regarding cross-connection to water supply.

Do not exceed 150° F (65° C) water temperature to pump in a direct supply system.

Connect a hose with at least a 3/4 in. (19 mm) ID from your city water supply to the unit's 3/4 garden hose threaded inlet. The supply hose should not be more

than 50 ft. (15 m) long. A 25 ft. (7 m) garden hose (107) is supplied with unit.

NOTE: For a direct supply system, your water source *must* have a flow rate of **AT LEAST 7.5 GPM (28 LITER/MIN)**. If it is less, we recommend using a siphon hose from a supply container.

Connect Siphon Hose

Remove swivel fitting (81) at water filter manifold (83) and screw siphon hose (104) into manifold. Squeeze clamp (105) together and route siphon hose through it. Release clamp and hook it over edge of drum so the top lip of clamp rests on the inside of drum and the lower lip rests against the outside of drum. See Fig 1. The hose should be between 2-4 inches (50-100 mm) off bottom of drum.

We recommend installing a float valve (A) on drum to maintain proper water level. See ACCESSORIES.

We do not recommend installing a shut-off valve at the intake as it could cause a pressure drop and cavitation in the pump. However, if you must have a shut-off valve, be sure it's inlet and outlet are the same size as the hose.

CAUTION

Do not exceed 70° F (28° C) water temperature to pump in a siphon supply system.

If your operating conditions are different from above, contact our Customer Service Department for assistance.

OPERATION

Startup

Before starting, be sure to read the safety warnings and setup instructions.

Check oil and gasoline levels daily and grease the pump if necessary.

Turn on the water supply.

Trigger the gun to release any back pressure.

WARNING

DO NOT wire or tie the gun trigger into the open or triggered position.

Set the choke and open the fuel valve.

WARNING

You must trigger the gun while starting, to avoid engine kickback.

Put your foot on the frame or wheel to steady the unit when you pull the starter rope. Hold the gun in your left hand with the trigger open while starting the engine. See Fig 2 for the proper stance. Brace the wand as shown to avoid recoil.

Grasp the starter rope grip and rapidly pull out the cord two or three feet (1 m). Repeat if necessary with the choke opened slightly. When the engine starts, immediately release the gun trigger. Open the choke gradually.

CAUTION

Never run the cleaning unit dry. Costly damage to the pump will result. Always be sure water supply is completely turned on before operating.

Inspect all connections for any leaks. Tighten if necessary.



Fig 2

Hydra-Clean Operation

Hold the spray nozzle about 2 feet (0.6 m) from the surface and completely mist-wet the object with cleaning solution. Let it soak briefly, then use the spray rinse to "chisel" the dirt off. Keep the nozzle at an angle to the surface, and about 6 in. (150 mm) away. If some dirt remains, repeat the procedure, letting it soak a little longer. When you have finished cleaning, shut off the unit and trigger the spray gun to relieve pressure.

Protect surfaces that might be damaged by the cleaning solution, and rinse before solution dries.

NOTE: You can clean off stubborn dirt better with a stronger, heated cleaning solution.

Shutdown and Care Of The Unit

CAUTION

When unit is not in use, turn off water supply.

When shutting down for the day or weekend, shut off unit, shut off water supply valve, and trigger gun to release pressure. Wipe off the unit with a damp rag.

Shut off cleaning unit when not actually spraying, for longer pump life. The pump will overheat if left running for over 10 minutes without spraying.

Check the filter screen in the water inlet connection as often as necessary. Do not operate the unit with the inlet filter screen removed.

DO NOT try to adjust the unloader valve or change the engine speed. Changing these settings may cause excessive pressure, intermittent unloader operation, wasted fuel and increased wear on parts.

PUMP MUST NOT BE RUN DRY and must be drained of water prior to exposure to freezing temperatures. Use and store the unit where it will not be subjected to freezing temperatures. If water does freeze in the unit, thaw before trying to start. A 50% anti-freeze solution may be pumped prior to cold weather storage.

Use only spray tips that are matched to unit to avoid excessive cycling and wear of the unloader valve. See ACCESSORIES.

CAUTION

Let a frozen pump thaw in a warm place. Don't pour hot water on a frozen pump. A sudden temperature change greater than 100° F (30° C) will crack the ceramic cylinder liners.

Do not pump caustic materials.

Before extended storage, flush the pump with light oil.

Observe oil change, gasoline, and greasing requirements as outlined on page 2 and the engine manual.

Avoid dragging hose over an abrasive surface such as cement. This causes wear and eventual rupturing.

Clean the intake line strainer daily.

Lubrication

Change the engine oil after every 50 hours of operation. Grease the pump's front bearing and main bearing after every 80 hours of operation. Remove excess grease from the front bearing cavity. Replace the pump front cover before starting the engine.

Lubricate the gear reduction unit regularly: change the oil every 500 hours, but sooner if oil becomes dirty. The engine manufacturer recommends using "For Service SD or SE" S.A.E. 30 oil for spring, summer, or fall operation, and S.A.E. 20 for winter operation.

Drain oil with engine warm. Place pan under reduction unit and loosen cover.

NOTE: Once a year, remove engine cover completely and flush out inside of housing with kerosene. DO NOT use gasoline for cleaning.

Remove filler and level plugs. Pour oil through vent hole of filler plug until it runs out through level hole. About 3/8 pint (177 cc) is required. Replace oil level plug and vented filler plug.

When changing engine crankcase oil, check reduction

unit and add oil if necessary to maintain proper level.

NOTE: Vented filler plug should be removed periodically and vent hole thoroughly cleaned. Ventilation is necessary to eliminate pressure build-up causing oil leaks, and to prevent condensation from forming in the housing.

Follow the maintenance procedures for the engine outlined in the accompanying instructions.

The accumulator (80) which acts as a buffer to smooth pump strokes, is nitrogen charged and must be recharged generally every 6 to 12 months to 540-660 psi (37-45 bar). Contact a local fire extinguisher service location for recharging.

CAUTION

Never remove stem valve from accumulator, or check its pressure with a standard tire pressure gauge.

Never try to recharge accumulator with ordinary car service station equipment.

TROUBLESHOOTING

<p>Engine Will Not Start Or Hard To Start</p>	<p>No gasoline in fuel tank or carburetor.</p> <p>Water in gasoline or old fuel.</p> <p>Choked improperly. Flooded engine.</p> <p>Dirty carburetor air filter.</p> <p>Spark plug dirty or improper gap.</p> <p>Spray valve closed.</p>	<p>Fill the tank with gasoline, open fuel shut-off valve. Check fuel line and carburetor.</p> <p>Drain fuel tank and carburetor. Use new fuel and dry spark plug.</p> <p>Push in choke, open throttle control and crank engine several times to clear out the gas.</p> <p>Remove and clean.</p> <p>Clean, adjust the gap or replace.</p> <p>Open valve.</p>
<p>Engine Misses Or Lacks Power</p>	<p>Partially plugged air cleaner.</p> <p>Low oil level or dirty oil.</p> <p>Spark plug dirty, wrong gap, or wrong type.</p> <p>Incorrect ignition timing.</p>	<p>Remove and clean.</p> <p>Check or change oil.</p> <p>Clean, adjust the gap, or replace.</p> <p>Time engine.</p>
<p>Excessive Machine Vibration</p>	<p>Worn shaft couplers.</p>	<p>Replace couplers or coupler insert.</p>
<p>Excessive Vibration Of Hose</p>	<p>Loss of dampener charge.</p> <p>Damaged pulsation dampener bladder.</p>	<p>Recharge with approximately 540-660 psi (37-45 bar) of nitrogen.</p> <p>Replace accumulator.</p>
<p>Decrease Delivery Accompanied By Rough Operation</p>	<p>Air entering suction piping;</p> <p>Air leaking past piston cups;</p> <p>Pump valve malfunction;</p> <p>Plugged or restricted pump suction passages;</p>	<p>Examine the valve seats for wear and pitting. Replace if necessary.</p> <p>Arrange a barrel or tank to collect discharged water from pump. Compare this to the rated capacity to see if the discharge has actually decreased.</p>

	<p>Plugged or constricted suction piping (suction valve not fully open);</p> <p>Collapsed suction hose.</p>	<p>Examine the water in the barrel or tank for air bubbles while the pump is discharging. If no bubbles are seen and the discharge has actually decreased, look for plug-ups, worn valve seats, or collapsed suction hose. If bubbles are seen, look for air leaks in the suction piping or for air leaking past the piston cups. These leaks are hard to find because they are leaking "in" rather than "out". However, if arrangements are made to put pressure into the suction piping or if new cups smooth out the pump operation, the problem is solved.</p>
<p>Decreased Delivery Accompanied By Smooth Operation</p>	<p>Worn valve seats.</p> <p>Slipping couplers.</p>	<p>Look for worn or pitted valve seats. Replace if necessary.</p> <p>Measure clearance between outer surface of eccentric roller bearing and yoke pads with a feeler gauge. This should not exceed 0.010 inch (0.254 mm).</p> <p>NOTE: Worn yoke pads will give a very noisy operation. Replace the yoke or pads if necessary.</p>
<p>Excessive Leakage</p>	<p>Worn piston cups;</p> <p>Loose piston bolts;</p> <p>Damaged o-rings;</p> <p>Cracked ceramic liners;</p> <p>Faulty gaskets;</p> <p>Loose valve caps;</p> <p>Loose cylinder head bolts or malfitted heads.</p>	<p>Examine pistons and cups for wear. Generally a cup will not leak severely until it is torn. The piston should not be more than 0.020 in. (0.508 mm) out of round.</p> <p>Tighten loose piston bolts, cylinder head bolts and valve caps. Remove head and sand flat part on 80-grit sandpaper which is laid on a flat surface.</p> <p>Check o-rings and gaskets for wear or breaks.</p> <p>Remove cylinder heads and blocks to examine ceramic liners for cracks. Replace all damaged parts.</p>

SERVICE

Pistons and Yoke

Take off the cylinder head (14) by removing four 1/2 in. socket head capscrews (A). See Fig 3.

Use a 7/32 in. socket wrench to unscrew the piston bolt (13) from the yoke. Slide out the cylinder liner (21) and piston assembly. Leave the yoke in place.

Examine the ceramic cylinder liner (21) for cracks. Replace worn or cracked parts before reassembling into pump body.

NOTE: Dirty grease sludge adhering to the wall of the cylinder liner should be removed with emery cloth before the liner is replaced in the pump body.

Assemble all piston parts (10, 11, 12, 13, 21, 22, 23, 24) as shown and push the assembly into the cylinder liner. Make sure that the o-ring is in the recess of the piston cap.

Screw the piston bolt into the yoke. The bolt has a countersunk head capscrew of the lockwell type and will require a little extra effort to turn. Make certain it is tight to prevent leakage through the bolt hole.

Repeat the procedure for the opposite side of the pump.

Valve Replacement

Mount the valve disc (6) on the spring (7). See Fig 3. Then mount the spring in the cage recess (8). Slip this assembly into the head cavities behind the valve seat (5) and o-rings (4). Put the valve caps (15) over these and install bolts (16).

Make sure that the o-rings (2 & 3) have been inserted in the proper places according to the diagram. It is wise to grease the head o-rings to prevent them from falling out during assembly.

Bolting Cylinder Head Assembly To Pump Body

Install the cylinder (14) head right side up on the pump body, as shown.

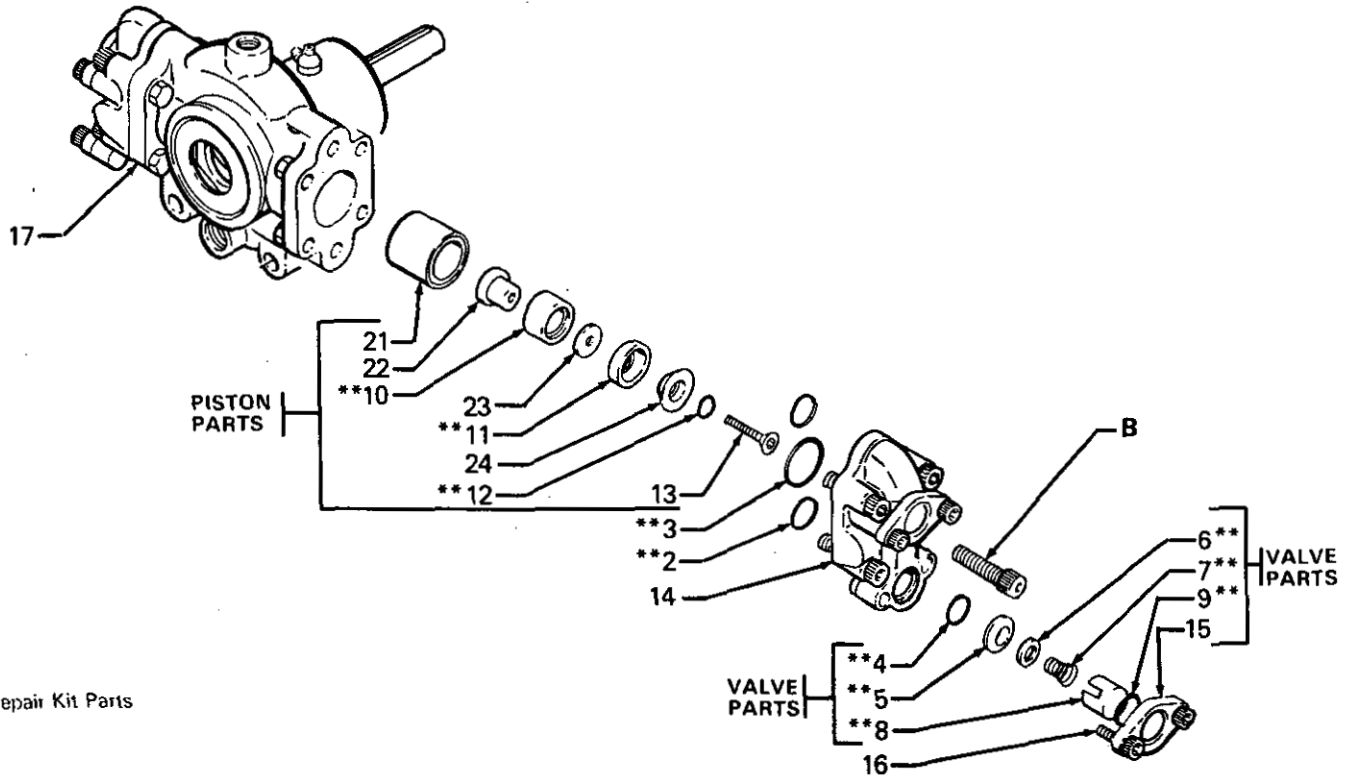

Fig 3

Unloader

Remove the locknut (67), adjusting nut (68) and spring washers (71).

Remove bolts (51) and separate the upper and lower casings (48 and 49). All other parts can then be freely removed.

To replace the cup and back-up ring (46 and 47):

- Cut through the old cup and back-up ring and remove them from the valve stem.
- Grip the shaft sleeve (69) in a vise equipped with jaw protectors.
- Slowly heat the end of the valve stem and piston (65) with a propane torch. When the assembly is hot enough, (about 250° F [120° C]) the piston can be easily screwed off the valve stem by firmly gripping with a pair of pliers.
- After the assembly cools, mount a new back-up ring and cup on the piston.
- Before replacing the piston, put a few drops of locking compound on the valve stem threads.

Items 69 and 70 are supplied as a unit and should not be disassembled.

Assemble in reverse order with the following precautions:

- Be certain the by-pass valve seat (58) is installed with the flat side of the valve against the valve ball (60).
- The first spring washer (71) is installed concave side downward and the remaining springs are alternated as shown. See Fig 4.

CAUTION

Never shim or alter the 17 spring washers (71) as this will cause the unit to over pressurize and damage itself.

To readjust the pressure of the unloader valve:

- Replace the 1/4 in. pipe plug (102) in the outlet manifold (101) with a 1500 psi (103 bar) min. pressure gauge.
- Screw the adjusting nut (68) into the stem (69) until approximately 1/8 in. of thread is exposed.
- Start the unit according to operation instructions on page 2.

- The unit should "unload" at 1050 to 1150 psi (72-79 bar) water pressure. Close the spray valve and note pressure. Continue adjusting the nut, closing the spray valve, and checking pressure until required pressure is obtained. Tighten the locknut. Check the unloading pressure a couple more times by triggering the gun and noting pressure.

- Shut off the unit, trigger gun to relieve pressure, remove the gauge and replace the pipe plug.

NOTE: Increasing valve unloader pressure beyond specified setting will not increase tip pressure or flow rate.

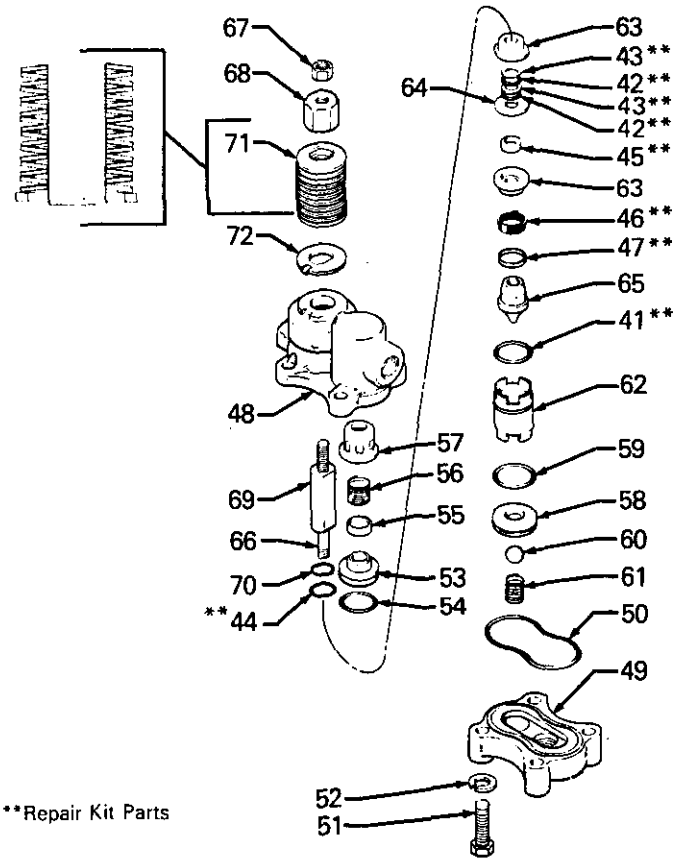
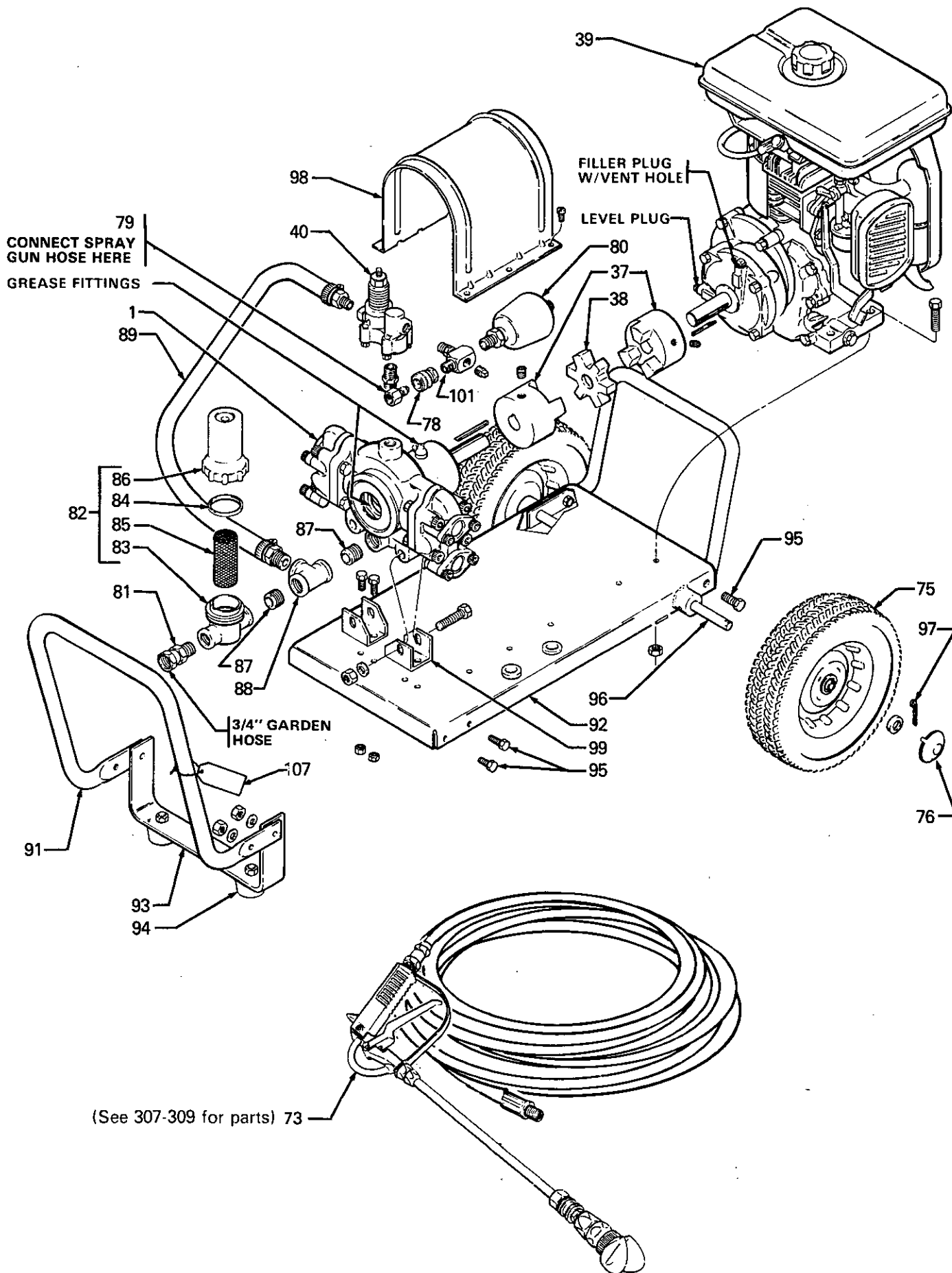

Fig 4

MODEL 226-813 SERIES "A"
WITH HOSE, GUN AND NOZZLE
 Includes items 1-102



PARTS LIST

REF NO.	PART NO.	DESCRIPTION	QTY	REF NO.	PART NO.	DESCRIPTION	QTY
1	*104-868	PUMP ASSY Includes items 2-36	1	56		. SPRING, compression	1
2	**	. PACKING, o-ring	4	57		. RETAINER, valve spring	1
3	**	. PACKING, o-ring	2	58		. SEAT, valve	1
4	**	. PACKING, o-ring	4	59		. PACKING, o-ring	1
5	**	. SEAT, valve	4	60		. BALL, check valve	1
6	**	. DISC, valve; ceramic	4	61		. SPRING, compression	1
7	**	. SPRING, valve; tapered compression	4	62		. CYLINDER	1
8	**	. CAGE, valve	4	63		. SLEEVE, limiting	2
9	**	. PACKING, o-ring	4	64		. WASHER	1
10	**	. PISTON, phenolic	2	65		. PISTON	1
11	**	. CUP, piston	2	66		. STEM, valve	1
12	**	. PACKING, o-ring	2	67		. LOCKNUT	1
13		. BOLT, piston	4	68		. NUT, adjusting	1
14	105-304	. CYLINDER HEAD	2	69		. SLEEVE, shaft	1
15	105-301	. CAP, valve	2	70		. WASHER	1
16	100-659	. CAP SCREW, socket head	8	71		. WASHER, spring	17
17		. HOUSING, pump	1	72		. WASHER	1
18		. YOKE	1	73	214-728	HOSE & GUN KIT, See 307-309 for parts	1
19		. PAD, yoke	2	74	*174-063	. WHEEL, semi-pneumatic	2
20		. COVER	1	76	104-811	. CAP, hub	2
21	*104-870	. LINER, cylinder; ceramic	4	78	104-871	. COUPLER, female	1
22		. SPACER, piston	4	79	104-872	. COUPLER, male	1
23		. WASHER, packing	4	80	*104-869	. ACCUMULATOR	1
24		. CAP, piston	4	81		. UNION, straight swivel	1
25		. LOCKNUT	1	82	104-863	. WATER FILTER ASSY. Includes items 83-86	1
26		. LOCKWASHER	1	83	105-305	. MANIFOLD, filter	1
27		. SPACER, outer bearing	1	84	104-864	. GASKET, rubber	1
28		. SEAL, bearing	2	85	*104-865	. SCREEN, filter; 80 mesh	1
29		. BEARING; tapered roller	2	86	*105-330	. BOWL, filter	1
30		. RACE, bearing	2	87		. NIPPLE, pipe; 3/4 npt	1
31		. SPACER, inner bearing	1	88		. TEE, pipe; 3/4 npt	1
32		. CRANKSHAFT	1	89	*104-866	. HOSE	1
33		. BEARING, eccentric	1	91	105-306	. HANDLE	1
34		. WASHER, retainer	1	92		. PLATE	1
35		. LOCKWASHER, spring; 3/8 in.	1	93		. BRACKET	1
36		. CAPSCREW	1	94	*104-860	. CREEPER	2
37	*104-862	. COUPLER	1	95		. BOLT	4
38	*104-861	. INSERT, coupler	1	96		. AXLE	1
39		. ENGINE, gasoline; 7.5 hp	1	97		. PIN, cotter	2
40	*104-853	UNLOADER ASSY. Includes items 41-72	1	98		. GUARD, couper	1
41	**	. PACKING, o-ring	1	99		. BRACKET, pump	2
42	**	. PACKING, o-ring	2	101		. MANIFOLD ASSY	1
43	**	. WASHER, shaft	2	103	214-828	. SPRAYER ASSY. Includes items 1-72, 75-101	1
44	**	. LIMIT, o-ring	1	104	215-427	. HOSE, siphon; 1-1/4 in. ID 6 ft. (1.8m) lg	1
45	**	. PACKING, shaft	1	105	176-741	. CLAMP, hose	1
46	**	. CUP	1	106	176-724	. TAG, caution	1
47	**	. BACKUP	1	107	105-435	. HOSE, garden, 3/4 in. thread cplgs; 25 ft. (7 m) lg	1
48		. HOUSING, upper	1	108	104-867	. CHEMICAL INJECTOR KIT See 307-325 for parts	
49		. HOUSING, lower	1				
50		. PACKING, o-ring	1				
51		. CAPSCREW, hex hd	4				
52		. LOCKWASHER, spring	4				
53		. SEAL, inlet valve	1				
54		. VALVE, inlet	1				

REPAIR KITS

PISTON KIT 104-856

Includes items 10, 11, 12.

VALVE KIT 104-855

Includes items 2-9.

UNLOADER VALVE KIT 104-854

Includes items 41-47.

306 & 307 Numbers in description refer to separate instruction manuals.

*Recommended "tool box" spare parts. Keep on hand to reduce down time.

**Supplied in repair kit. (Kit must be purchased separately).

Order parts by name and number. Always give the model number and series letter of the assembly for which you are ordering.

ACCESSORIES (Must be purchased separately)

SPRAY HOSES

Additional hoses may be used up to a maximum overall length of 150 ft (46 m) overall length. Purchase part no. 207-152 swivel union to connect hoses.

Part No.	I D	Length	Thd Size
205-753	3/8 in. (9.5 mm)	40 ft	3/8 npt (mbe)
205-609	1/2 in. (13 mm)	50 ft	3/8 npt (mbe)

CHECK VALVE 103-913

Prevents back up of contaminated water into fresh supply. Install upstream from pump.



FLOAT VALVE 205-971

Automatic shut-off valve prevents overfilling siphon supply drum.

STAINLESS STEEL BLASING TIP 102-488

0.107 in. (2.72 mm) orifice.

STAINLESS STEEL TIPS

Part No.	Number on tip	Orifice size	Fan Width Angle at 40 psi (3bar)
160-968	1520	0.109 in. (2.77 mm)	15°
160-962	2520	0.109 in. (2.77 mm)	25°
160-956*	4020	0.109 in. (2.77 mm)	40°

*Tip available on special order.

HOSE & GUN KIT 214-728

Same as hose and gun supplied with unit.

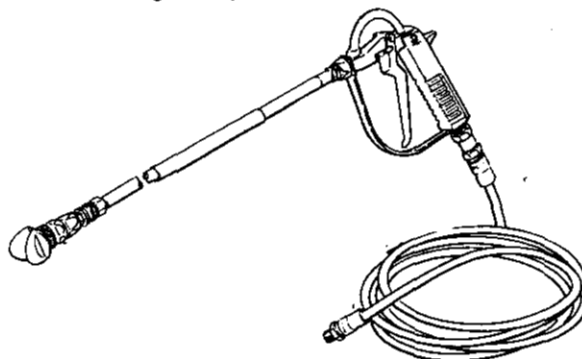

TECHNICAL DATA

ENGINE: WISCONSIN ROBIN, MODEL EY27W 4 cycle, single cylinder, air cooled, 7.5 hp

GASOLINE TANK: 1.45 gallon capacity

WATER PUMP: 1200 PSI (83 bar) max. pressure; 7 GPM (27 liter/min) at 1000 PSI (70 bar).

WETTED PARTS: Stainless Steel, Aluminum, Phenolic Plastic, Ceramic Liners, Nitrile Rubber.

WEIGHT: 170 lb (75 kg) (not including gasoline and motor oil).

OVERALL DIMENSIONS: Length: 50" (1.3 m)
Width: 22" (560 mm)
Height: 24" (610 mm)

MAX. WATER TEMPERATURE: 150° F (65° C)

INLET HOSE CONNECTION: 3/4" garden hose (f)

THE GRACO WARRANTY

Graco Inc. warrants all equipment manufactured by it and bearing its name to be free from defects in material and workmanship under normal use and service. This warranty extends to the original purchaser for a period of 12 months from the date of purchase and applies only when the equipment is installed and operated in accordance with written factory recommendations. This warranty does not cover damage or wear which, in the reasonable judgment of Graco, arises from misuse, abrasion, corrosion, negligence, accident, substitution of non-Graco parts, faulty installation or tampering.

This warranty is conditioned upon the prepaid return of the equipment claimed to be defective for examination by Graco to verify the claimed defect. If the claimed defect is verified, Graco will repair or replace free of charge, any defective parts. The equipment will be returned to the original purchaser transportation prepaid. If inspection of the equipment does not disclose any defect in workmanship or material, repairs will be made at a reasonable charge and return transportation will be charged.

THIS LIMITED WARRANTY IS EXCLUSIVE, AND IS IN LIEU OF ANY OTHER WARRANTIES (EXPRESS OR IMPLIED) INCLUDING WARRANTY OF MERCHANTABILITY OR WARRANTY OF FITNESS FOR A PARTICULAR PURPOSE AND OF ANY NON-CONTRACTUAL LIABILITIES INCLUDING PRODUCT LIABILITIES BASED ON NEGLIGENCE OR STRICT LIABILITY. EVERY FORM OF LIABILITY FOR DIRECT, SPECIAL OR CONSEQUENTIAL DAMAGES OR LOSS IS EXPRESSLY EXCLUDED AND DENIED.

EQUIPMENT NOT COVERED BY GRACO WARRANTY. Accessories or components of equipment sold by Graco that are not manufactured by Graco (such as electric motors, switches, hose, etc.) are subject to the warranty, if any, of their manufacturer. Graco will provide purchaser with reasonable assistance in making such claims.

Factory Branches: Atlanta, Cleveland, Dallas, Detroit (Southfield), Los Angeles, West Caldwell (N.J.)
Subsidiary and Affiliate Companies: Canada; England; Switzerland; France; Germany; Hong Kong; Japan
GRACO INC. P.O. BOX 1441 MINNEAPOLIS, MN 55440