



500kW Containerized Diesel Generator Set

Model	Emissions	Standby Rating	Prime Rating
EGC500DD	EPA Certified	60 Hertz	
		500kW (625kVA)	450kW (562kVA)



Standard Features

Detroit Diesel Heavy Duty Diesel Engine

- 4-cycle design, turbocharged, aftercooled, direct injection
- Polymide blade cooling fan
- Engine coolant heater
- Meets EPA emissions standards for mobile off-highway

Fuel System

- 800 gallon, single wall fuel tank
- Fuel priming system
- Fuel/water separators and drip pan
- External fuel fill
- Electric fuel pump
- 30 micron Racor® fuel filter system

Alternator

- Brushless, 4-pole, synchronous, WYE connection
- Class H insulation system conforms to NEMA MG1-22, BS5000, CSA-C22-2, IEC-34-1 standards for temperature rise
- Drip-proof, self-venting, amortisseur windings
- Epoxy impregnated windings with tropical insulation for increased environmental protection and long life

Electronic Voltage Regulator

- Electronic automatic voltage regulator provides precise regulation
- Separate three-phase excitation for fast recovery from block loads and motor starting

Full Load Acceptance

- Accepts 100% of standby nameplate rating in one step, in compliance with NFPA, para 5-13.2.6

Generator Control Panel

- Intelligen™ vibration-isolated controller
- Manual or remote engine start/stop
- RS232/Modbus communication support
- Safety shutdowns
- Externally mounted emergency stop switch
- Generator mainline circuit breaker, 100% rated, electronically operated, UL listed

Specially Designed Container

- 20 ft. ISO container, sound-attenuated, foam-lined for extremely quiet operation
- Solidly mounted battery rack and cooling system
- Integral vibration isolators
- Exterior polyurethane coating system provides long life in extreme operating conditions
- Interior DC lights and timer switch
- Critical grade silencer with heat blankets
- Crankcase filtration system

Warranty

- Engine-generator sets are covered by an express written, one-year limited warranty



500kW Containerized Diesel Generator Set

APPLICATION DATA

Alternator Specifications

Make	Marathon Magna Max
Type	4-Pole, Rotating Field
Number of Leads	10 or 12
Generator Type	Rotating Field; PMG
Voltage Regulator	Solid State, Digital, Model DVR2000
Insulation	NEMA MG1-1.66
Material	Class H
Temperature Rise	Standby Rating: 125° C Prime Rating: 105° C
Bearing: Number, Type	Single, Sealed
Coupling	Flexible Disk
Amortisseur Windings	Full
Voltage Regulation (no load to full load)	2% Maximum
One Step Load Acceptance % of rating per NFPA-110	100
Peak Motor Starting HP	250
Generator Efficiency at Full Load	93%
Phase Sequence	ABC (L1, L2, L3)
L-L Harmonic Max Total	3.5%
L-L Harmonic Max Single	2.5%
Voltage Dip Upon Full Load Application (1 Step)	20% for 1.6 seconds
Voltage Rise Upon Full Load Rejection (1 Step)	14% for 0.6 of a second

The EGC500DD Sound Attenuated Generator is configured for standard 60 Hz, 208V and 480V output. Special voltage outputs are available (special order).

Alternator Features

- All ratings tested per MIL-STD-705 as applicable.
- Generator protection for overload and short circuit.
- Generator is designed and built within NEMA, IEEE and ANSI standards for temperature rise.
- PMG exciter for superior regulation and response.
- Three phase sensing on regulator with EMI protection.
- Skewed rotor for smooth voltage wave form.
- Vacuum impregnated epoxy varnish - Fungus resistant per MIL-I-24092.
- Sustain short circuit current at 300% of rated current up to 10 seconds.

Engine Specifications

Manufacturer/Model	Detroit Diesel 8V2000-G81
Engine Type	4-cycle, Turbocharged, Air to Water Aftercooled
Cylinder Arrangement	V-8
Displacement	972 in ³ (16 liter)
Bore	5.12 in. (130 mm)
Stroke	5.91 in. (150 mm)
Compression Ratio	14.5:1
Piston Speed (60Hz)	29.5 ft./sec. (9.0 m/sec)
Bearing Main: Number	5
Bearing Main: Type	Replaceable, Precision
Cylinder Block	Cast iron
Cylinder Head Material	Cast iron
Crankshaft Material	Forged steel
Valves	Dual, Poppet Type
Brake Mean Effective Pressure (BMEP)	346 psi (2385 Kpa)
Rated RPM (60 Hz)	1800
Max. Power At Rated RPM (with fan)	765 hp (570.5 kW)
Governor: Type	Electronic
Frequency Regulation: No load to full load	±0.10 Hz
Frequency Regulation: Steady State	±0.05 Hz
Air Cleaner Type - All Models	Dry, Dual Element

Amperage

Voltage	Phase	Power Factor	Continuous Amperes	
			Standby	Prime
120/208	3	0.8	1734	1561
277/480	3	0.8	752	677

Engine Electrical System

Battery Charging Alternator Ground Type	Negative
Volts	24 VDC
Ampere Rating	70A
Starter Motor Rated Voltage	24 VDC
Minimum Recommended Battery for 0 °C / Cold Cranking Performance	800 Ah

Derating

Derating Factors (60 Hz)	Altitude	Ambient Temperature
The engine may be operated up to 2000 ft. altitude and 40°C ambient temperature at the Standby rating, without derating. For operation at higher altitudes and ambient temperatures, the power should be derated according to the following factors:	>2000 m = 4% per 500 m	>40 °C = 1.5% per 5 °C



500kW Containerized Diesel Generator Set

Cooling System

Exhaust Manifold Type	Dry
Radiator Design	Standard horizontal discharge
Coolant Capacity - Engine	11.6 gal. (44 L)
Coolant Capacity - Engine and Radiator	42 gal. (159 L)
Water Pump Design/Type	Belt Driven, Centrifugal
Coolant Flow	79 gal/min (299 L)
Heat Rejection to Coolant	11535 BTU/min (202.7 kW)
Fan Horsepower	23 hp (17 kW)
Thermostat	188.6 °F (87 °C)

Fuel System

Recommended Fuel	ASTM-D975-No.1 or No. 2-D	
Fuel Pump Maximum Lift	6.0 ft. (1.8 m)	
Filter Micron Size - 98% Efficiency	2	
Total Fuel Flow	186.1 gal./hr. (704.5 L/Hr.)	
Fuel Consumption		
Diesel Fuel @ % of Load	gal/hr	L/hr
25%	10.1	38.2
50%	18.1	68.5
75%	26.8	101.4
100%	37.7	142.7

Lubrication System

Type	Full Pressure System
Oil Filters	2 Spin-on, Full Flow
Oil Pan Capacity	12.2 gal. (46.0 L)
Oil Capacity with Filters	14.3 gal. (54.0 L)
Oil Pressure at Rated Speed	47 - 57 psi (324 - 393 kPa)

Exhaust System

Exhaust Temperature at Rated kW (Dry Exhaust)	980 °F (527 °C)
Exhaust Flow at Rated kW	4080 cfm (115.5 m³/min)
Silencer Type	Critical
Maximum Allowable Backpressure	41.1 in/wc (10.2 kPa)
Exhaust Outlet Size at hook-up	5.0 in. (127 mm)

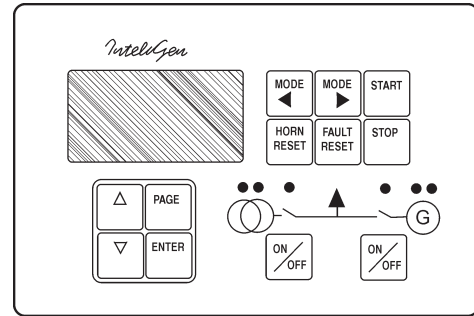

Inteligen Digital Genset Controller

Digital Controller Features

- Large graphic back-lit LCD display 128x64 pixel resolution
- Automatic and manual starting and stopping
- Phase sequence supervision
- Automatic shutdown/alarm function
- Input frequency 50-60 Hz
- Parameters adjustable via PC or iG keyboard
- Predefined and user definable configurations available. One configuration includes set of inputs/outputs and parameters
- Adjustable parameters for each configuration
- 6 LED indicators
- Push buttons for simple control
- 4 programmable outputs (out of 20 functions selection)
- 4 binary configuration inputs
- Lamp test during start up
- Real time clock
- Sealed membrane panel to IP65
- 180 x 113 mm front panel mounted case
- Speed measurement from magnetic pickup
- Oil pressure, Coolant temperature, Battery voltage and Fuel level measurements
- Running Hour Meter
- All Generator metering, kVAr, kW, V1-V3, Hz, I1-I3, kWh, kVAh
- Generator under/over voltage alarm/shutdown
- Generator under/over frequency alarm/shutdown
- Over Current alarm/shutdown
- Warm up and cooling functions
- Pre-lubrication function with timers
- Adjustable crank attempts
- Data logging
- Remote communications (RS232/Modbus)



500kW Containerized Diesel Generator Set

Optional Features and Accessories

Generator Set

- Genset-to-Genset Paralleling Control System
- Base Load-to-Utility Paralleling Control System
- Custom Outlet Panels
- Rotary Voltage Selector Switch (High Wye/Low Wye Voltages)
- Auxiliary Oil Reservoir with Level Control (15-gallon)
- Centrifugal Oil Filter System
- Oil Pan Heater with Thermostat
- Alternator Strip Heater
- AC Battery Charger with Shore Power Receptacle

Container

- ISO Trailer Chassis (20 ft.)
- Double-wall Fuel Tank (600-gallon capacity)
- Fluid Containment
- Manual Fuel Valves (For Internal or External Fuel Supply)
- Fueling Platform (Aluminum Step Construction with Hand Rail)
- Entrance Ladder (6-step, Aluminum Construction)
- Interior Lights (AC Work lights)
- Custom Paint Colors (Artic White is Standard)

SPECIAL OPTIONS AVAILABLE UPON REQUEST

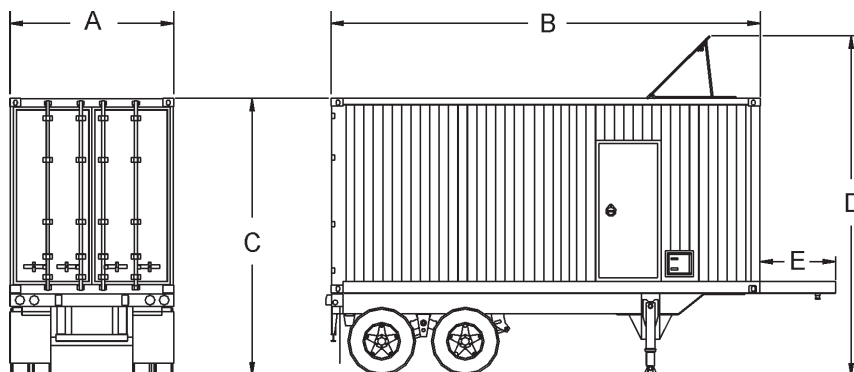

20 ft. Container

Weight and Dimensions

A	B	C	D	E
96 in. (2,438 mm)	238 in. (6,045 mm)	150 in. (3,810 mm)	177 in. (4,495 mm)	44 in. (1,117 mm)
Weight (Wet)*		22,500 lbs (10,206 kg)		
Weight (Wet with trailer)*		29,980 lbs (13,599 kg)		

* Weight is approximate. Wet weight does not include fuel.

Backfeed to a utility system can cause electrocution and/or property damage. Do not connect to any building's electrical system except through an approved device. Specifications are subject to change without notice.

Your MQ Power dealer is:



MQ POWER

POST OFFICE BOX 6254
 CARSON, CA 90749
 310-537-3700 • 800-421-1244
 FAX: 310-632-2656
 E-MAIL: mqpower@multiquip.com
 WEBSITE: www.mqpower.com