

Smart choice for power

xantrex



FP 3000-12

Owner's Manual

**Xantrex
Fleet Power™ 3000-12
Inverter/Charger**

www.xantrex.com

Thank you for purchasing a Xantrex Fleet Power™ 3000-12 Inverter/Charger. Xantrex Technology Inc. takes pride in manufacturing quality products specifically designed to meet your power requirements.

The FP3000-12 provides silent, efficient and reliable AC power for a variety of applications. It features “hands-free” operation, automatic three-stage battery charging and automatic AC transfer switching. For your convenience, service is available world-wide from qualified service centers.

If you have any questions about your Fleet Power 3000-12, please contact Xantrex toll free at **1-800-670-0707**.

For technical support and additional information about Xantrex products, visit our Web site at **www.xantrex.com** or email us at **CustomerService@xantrex.com**

SAFETY SUMMARY

Safety information for installation and operation is contained throughout this manual where it applies and is not included in this summary.

Definitions:

Warning statements identify conditions or practices which could result in personal injury, loss of life, damage to equipment or other property.

Fuse Replacement For continued protection against the possibility of fire, replace the fuse only with a fuse of the specified voltage, current and type ratings.

Power Source To avoid damage, operate the equipment only within the specified AC (line) and DC (battery) voltages.

Servicing To reduce the risk of electric shock do not open this unit. There are no user serviceable parts inside. Refer all service to qualified personnel.

Notice of Copyright

Xantrex Fleet Power 3000-12 Inverter/Charger © January 2003 Xantrex International. All rights reserved.

Fleet Power is a registered trademark of Xantrex International. Xantrex is a registered trademark of Xantrex International.

Disclaimer

UNLESS SPECIFICALLY AGREED TO IN WRITING, XANTREX TECHNOLOGY INC. (“XANTREX”)

(a) MAKES NO WARRANTY AS TO THE ACCURACY, SUFFICIENCY OR SUITABILITY OF ANY TECHNICAL OR OTHER INFORMATION PROVIDED IN ITS MANUALS OR OTHER DOCUMENTATION.

(b) ASSUMES NO RESPONSIBILITY OR LIABILITY FOR LOSS OR DAMAGE, WHETHER DIRECT, INDIRECT, CONSEQUENTIAL OR INCIDENTAL, WHICH MIGHT ARISE OUT OF THE USE OF SUCH INFORMATION. THE USE OF ANY SUCH INFORMATION WILL BE ENTIRELY AT THE USER’S RISK.

Date and Revision January 2003, Revision 2 **Part Number** 445-0206-01-01

Contact Information Web: www.xantrex.com Email: CustomerService@xantrex.com
Phone: 1-800-670-0707 (toll free in North America) 1-604-422-2777 (direct) Fax: 1-604-420-2145

TABLE OF CONTENTS

Introduction	4	Troubleshooting	31
Things You Should Know	5	LED Fault Status	
Circuit Breaker Protection		Glossary	33
Thermostat Controlled Cooling		Specifications	35
Inverter Idle Circuit		Installation Diagrams	37
Low and High Battery Shutdown		Warranty	43
Power Sharing			
Temperature Sensitive Charging			
Operation	7		
Optional Remote Control Panel	10		
Batteries	11		
Battery Types			
Battery Interconnection			
Battery Bank Ratings and Sizing			
Battery Charging	15		
Fleet Power Battery Chargers			
Battery Charger Voltage Table	20		
Installation Precautions	21		
Installation	22		
Key Installation Points			
Grounding			
Neutral Bonding			
AC Wiring			
AC Input			
AC Output			
Ground Fault Circuit Interrupters			
Remote Control Wiring			
TSC Temperature Sensitive Charging			
DC Wiring			
Battery Cable Fusing			
Power ON Checks			

Not recommended for use in marine environment

INTRODUCTION

This owner's manual describes the Fleet Power™ 3000-12 Inverter/Charger from Xantrex Technology Inc. This unit performs three distinct functions:

- 1. DC to AC power inverting.**
- 2. Automatic transfer switching between inverter power and incoming AC power.**
- 3. Automatic three-stage battery charging plus manual battery equalizing.**

- The inverter provides regulated 120 volt AC power at a crystal controlled frequency from a deep-cycle battery bank and is rated at 3000 watts.

The output is a modified sine wave and is compatible with most appliances, tools and other 120 VAC equipment. (Note: certain laser printers, breadmakers, digital clocks and small battery chargers may not operate on modified sine wave.) An idle mode reduces battery power consumption when loads are removed from the inverter. There is a low battery cutout protection circuit and momentary surge power of more than twice the inverter rating for starting electric motors. High efficiency ensures the longest possible battery life between charges.

- The internal transfer switch allows the FP3000-12 to be connected to an external AC source and transfer the source power through directly to the loads. When the external AC power source is disconnected, the transfer switch allows automatic switching back to the inverter.

The FP3000-12 operates as a self-contained backup power system—just add batteries.

- The FP3000-12 battery charger is electronically controlled and rated at a maximum output current of 140 amps DC.

It is designed to rapidly and optimally charge wet, gel, or Absorbed Glass Mat (AGM)** cell deep-cycle batteries. Battery charging is automatically accomplished in three stages: Bulk Charge, Acceptance Charge and Float Charge.

Using a Remote Control Panel, a manually engaged Equalizing Charge cycle is possible. Simple, automatic operation is made possible by the microprocessor in the FP3000-12. In most cases, no attention or maintenance is required.

Electronic Protection

Fast-acting electronic circuits protect the inverter from overloads and short circuits. Other protection includes a low and high battery voltage cutoff and automatic shutdown if an over-temperature condition occurs. When the fault condition is corrected, the unit will automatically reset. Example: remove overload, charge batteries or allow to cool.

**Battery type selection is set on the front of the unit or with the Remote Control Panel.

THINGS YOU SHOULD KNOW

Circuit Breaker Protection

The FP3000-12 is supplemental breaker protected.

The INVERT/CHARGE breaker on the front of the unit protects against sustained inverter/charger over-current conditions. These breakers are reset by pushing the button back in. The output circuit breakers protect the output AC circuits. The FP3000-12 is available with one or two outputs.

Thermostat Controlled Cooling

The FP3000-12 is equipped with a thermostatically controlled fan that cools the unit so it can operate continually at its rated Units with only supplemental circuit breakers between the unit and the load. Appropriate wire gauges must be used throughout the installation. Refer to NEC specifications.

Circuit Breaker Protection		
INV/CHG	OUT 1	OUT 2
30	N/A	N/A

Note: Supplemental circuit breakers are reset by pushing the button back in. The fault must be removed before resetting the circuit breaker. Integral branch circuit rated breakers are reset by setting the appropriate breaker switch to the "on" position. The fault must be removed before resetting the circuit breaker.

If a 30-ampere service supplies the input to the unit, a model with integral branch circuit rated breakers allows direct wiring from the unit to the load.

Inverter Idle Circuit

This automatic energy-saving feature reduces battery power consumption when no AC load is present. Response from idle is instantaneous. In most cases, the operation of the idle circuit is not noticeable. Use of the Remote Control Panel allows the idle threshold to be adjusted. The unit does not put out 120 volts when in idle. To bring the unit out of the idle condition, apply a load.

Low and High Battery Shutdown

When in inverter mode, if the battery voltage drops to 10.0 volts, the inverter will automatically shut off. Charge the batteries to 13.5 volts to automatically resume operation.

Voltage shutdown also occurs for a high battery condition at 15.5 volts. Operation will resume automatically when the battery voltage drops below 15.5 volts. Check all DC sources on the system for the reason for the excessive voltage.

Power Sharing

When connected to an external AC source the battery charger and transfer functions are engaged. A unique Power Sharing feature automatically reduces the AC power consumption of the battery charger allowing necessary AC power to go to the load. This prevents the source AC INPUT circuit breaker from tripping within the specified rating of the AC circuit breaker.

The Power Sharing set point of each unit has a factory default setting of 30 amps. This can be changed using the Remote Control Panel.

THINGS YOU SHOULD KNOW

Temperature Sensitive Charging (TSC)

When the supplied battery temperature sensor is connected to the unit and the batteries, the charge voltage is controlled based on battery temperature. The charger adjusts the charge voltage to the best level, minimizing water loss in wet cell batteries. Charge voltage regulation optimizes the battery life cycle.

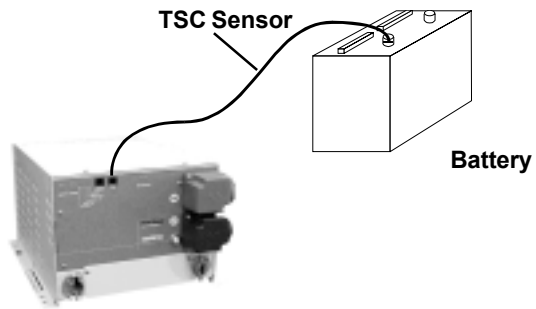

OPERATION

The FP3000-12 provides 120 volt AC power from auxiliary DC batteries, automatic battery charging and automatic AC transfer switching between an external AC source and inverter mode.

External AC Power

When external AC power is available, the three-stage battery charger, transfer switching, and Power Sharing automatically function.

When external AC power is not available and the INVERT switch is ON (either through the auxiliary switch or the INVERT button on the remote), the inverter will automatically turn ON. If the INVERT switch is OFF (the INVERT LED will not be illuminated), the inverter will be OFF.

If installed with the Remote Control Panel, the unit will be set up and controlled from the remote. Refer to the remote manual for more information.

Front Panel Controls and Indicators

INVERT MODE

The INVERT push-button switch is located on the front of the unit and has two functions:

- Turn the inverter ON/OFF and reset after a fault condition. Pressing the INVERT switch turns the inverter ON. The green INVERT LED will be ON when the inverter is inverting. When the inverter is ON, pressing the INVERT switch turns the inverter OFF.

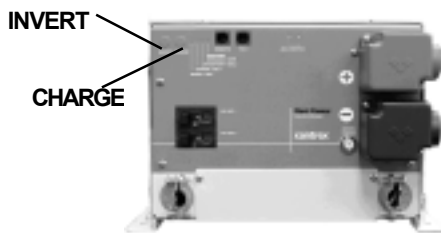

- Battery type setup. To enter the battery type select mode, press and hold the INVERT switch for five seconds. The status LEDs will change from indicating status information to indicating battery type. The selection of the battery type is made with the Charge switch.

Turning the INVERT OFF will reduce battery power consumption to a very low level. This is recommended if the unit will not be used for an extended period of time.

CHARGE MODE

The CHARGE push-button switch has two functions:

• Turn the charger ON and OFF

If external AC is present, pressing the CHARGE switch will turn the charger ON. The green CHARGE LED will be ON when the charger is charging. When the charger is ON, pressing this switch will turn the charger OFF.

- **Select the battery type** After holding the INVERT switch for five seconds, press the CHARGE switch to select the battery type. One of the four LEDs will rapidly blink, indicating the present battery type setting. Press the CHARGE switch again to change the battery type. Continue to press until the desired battery type is selected. If the CHARGE switch is not pressed for five seconds, the unit will return to normal operation and the battery type selection will have been made.

When the 12 volt input to the unit is disconnected, the battery type setting is stored in non-volatile memory. When the unit is reconnected, the battery type selection conveniently returns to the setting.

OPERATION

STATUS LEDs

Each Status LED performs two functions, providing battery type selection and operation status.

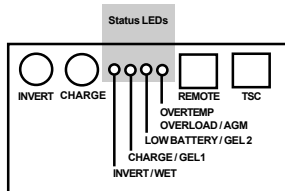

Battery Type Selection

After holding the INVERT button down for five seconds, use the CHARGE button to select battery type :

WET GEL 1 GEL 2 AGM

Operation Status

INVERT - Green LED

The INVERT push-button switch is located on the front of the unit.

- When the LED is solid green, the unit is in invert mode. This occurs by pressing the INVERT switch (for three to five seconds).
- When the LED is blinking slowly (once per second), the inverter is in standby with AC power applied and the transfer switch engaged
- Press the INVERT switch again to turn the inverter OFF.

CHARGE - Green LED

• The CHARGE push-button switch is located on the front of the unit.

When external AC is applied to the AC input of the unit, the charger automatically turns ON. The CHARGE LED will be solid green.

- When the LED is blinking slowly, (once per second) the charger is ready, but external AC power is not available.

- Press the CHARGE switch again to turn the charger OFF. The charger defaults to ON when operating without a remote or with the Remote Control Panel.

- When the LED is OFF, the charger has been manually turned OFF. This can only be accomplished while AC power is being supplied.

NOTE: When AC power is available, the default setting for the charger is ON. If the unit was manually turned OFF and AC power is interrupted and becomes available again, the charger will return to ON.

LOW BATTERY - Red LED

- When the LED is OFF the battery voltage is normal, between 10.5 and 15.0 volts DC.
- When the LED is solid red, it indicates a battery warning condition, the battery voltage is below 10.5 volts DC or above 15.0 volts DC.
- When the LED is blinking slowly (once per second), a battery shutdown has occurred. The voltage is either below 10.0 volts DC or above 15.5 volts DC.

- When the LED is blinking rapidly (five times per second), a potential problem in the DC system has been detected. Check your batteries, battery cables and DC loads.

OVERTEMP/OVERLOAD - Red LED

- When the LED is OFF, operation is normal.

- When the LED is red, there is an over temp or overload condition. Check for excessive loads or short circuit on the output of the inverter. Correct the condition and restart by pushing the INVERT switch.

OPERATION

- When the LED is blinking slowly (once per second), an over-current condition or a short circuit has occurred. The system has shut OFF and will not automatically restart. Correct the fault condition and manually restart the system.

LOW BATTERY & OVERTEMP/OVERLOAD

- Red LEDs

- When both LEDs are blinking, an AC backfeed has been detected. A backfeed occurs when AC power from an external source is connected to the output of the inverter. Inspect wiring for a possible input/output wiring error. This condition will damage the unit and must be corrected before further operation.

TSC (Temperature Sensitive Charging)

This provides for the connection of a sensor to measure battery temperature for compensated charging. If no sensor is connected the charge voltage levels are set to defaults based on battery type.

OPTIONAL REMOTES

If using a remote, refer to the installation instructions included with the remote.

Note: When a Remote Control Panel is installed, the jumper included in the parts plastic bag is **not** used in the Auxiliary Switch Port (AUX SWITCH) on the front panel of the inverter/charger. See page 23 for more details.

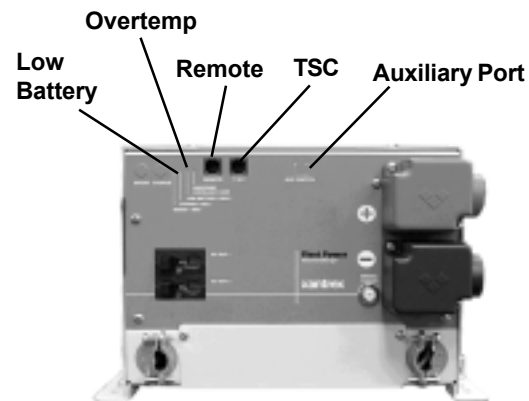

OPTIONAL REMOTE CONTROL PANEL

Remote Control Panel

An optional remote control panel is available. The LED bar graphs on the remote control panel show battery voltage and DC current in both inverter and charger modes.

Easy-to-see red, yellow and green LEDs show the battery state-of-charge. Power Sharing, charger ON/OFF, inverter ON/OFF controls are provided. Set-up features include selection of Idle Threshold, Battery Type and Battery Capacity.

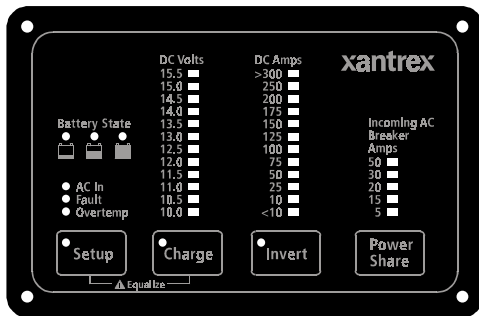

Remote Control Panel

BATTERIES

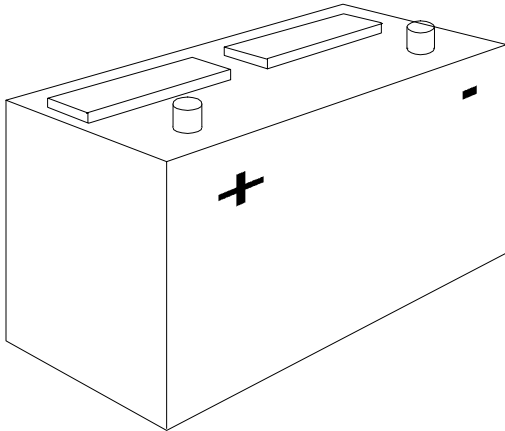

BATTERY TYPES

Use only deep-cycle batteries with your FP3000-12. These fall into three broad categories: wet cell, gel cell and Advanced AGM (Absorbed Glass Mat) batteries.

Wet Cell Batteries

True deep-cycle wet cell batteries are characterized by relatively thick internal plates that are alloyed with antimony.

Common 12-volt marine/RV deep-cycle batteries are acceptable. Golf cart batteries perform well and may have a longer life. These 6-volt batteries must be used in series connected in pairs. **High quality deep-cycle batteries offer good performance** and are available in a wide variety of sizes.

Wet cell batteries will give off gas as a natural result of charging and will experience some water loss. It is **very important that the electrolyte level be checked frequently** and topped off with distilled water when necessary. Follow the battery manufacturer's recommendations for maintenance.

Never allow the top of the battery plates to be exposed to air, as contamination of the cell will result. Keep the top of batteries clean. Always provide adequate ventilation for the battery storage compartment.

Do not use ordinary car batteries or engine starting batteries with your inverter-charger. Beware of any battery that is rated in Cold Cranking Amps (CCA). This is a rating which applies only to engine starting batteries. In general, most wet cell batteries that are described as hybrid type batteries, suitable for either engine starting or deep-cycle applications, are a compromise and will have limited life if deeply discharged.

BATTERIES

All batteries can be maintenance free, but not all of them are deep-cycling batteries. **Beware of batteries that are described as maintenance free only.** These batteries have calcium alloyed with the lead and hold the liquid electrolyte in a sponge-like material. They are sealed and water cannot be added. *Do not confuse them with true gel cell or AGM batteries*—they will not hold up well to deep discharging and repeated cycling.

Gel Cell Batteries

Gel cell batteries are lead-acid batteries similar in many ways to the common wet cell battery, but differences in the chemistry and construction provide some unique features.

- No maintenance
- Low self-discharge rate
- Low internal resistance

Even though gel cells are sealed batteries, the battery compartment should still be ventilated.

Advanced AGM (Absorbed Glass Mat) Batteries

This battery is lead acid but maintenance-free. The performance is similar to gel cell batteries. The charge parameters are similar to wet cell batteries.

Battery Selection

The most important feature to consider in making your battery selection is to select true deep-cycle batteries rated in amp hours (Ah) and sized to match your power requirements.

BATTERY INTERCONNECTION

In most cases, you will be using a bank of two or more batteries with your inverter/charger. You may connect batteries together in two configurations, series and parallel, depending on their voltage.

Series

Connecting two batteries in series will double the voltage of the battery bank. For instance, two 6-volt batteries connected in series will produce 12 volts. The amp-hour capacity of the battery bank will be the same as each individual battery. For example, two 6-volt 220 amp-hour batteries in series will produce one 12-volt 220 amp-hour battery bank.

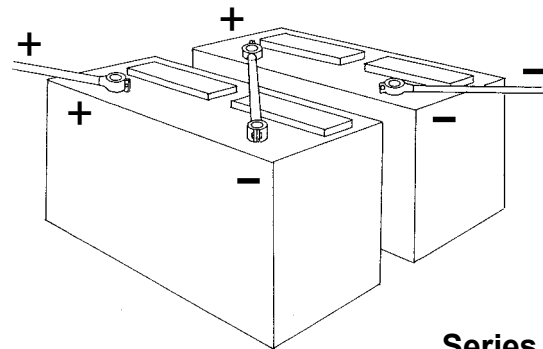

Series Increase Voltage

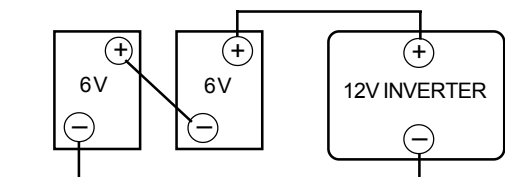

EACH BATTERY
CAPACITY:
220
AMP HOURS
@ 6 VDC

TOTAL BATTERY
BANK CAPACITY:
220
AMP HOURS
@ 12 VDC

BATTERIES

Parallel

Connecting two batteries in parallel will double the amp-hour rating of the battery bank, while the voltage will be the same as each individual battery. For example, two 12-volt 105 amp-hour batteries in parallel will produce one 12-volt 210 amp-hour battery bank.

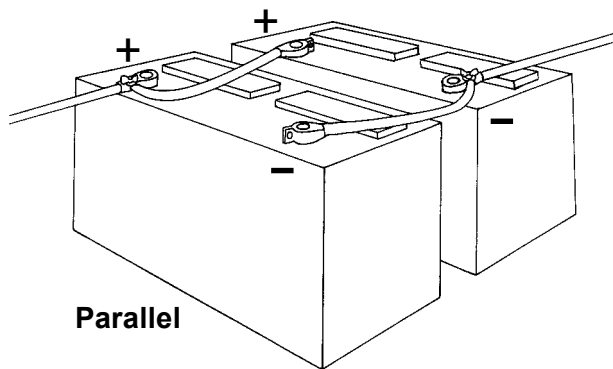

Parallel Increase Amp-hour Capacity

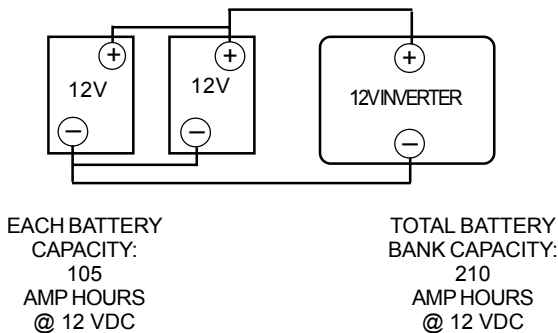

Only similar batteries should be connected together in one bank. Do not connect old and new batteries together or wet and gel cell batteries together. In the above drawing, the load is connected to the positive terminal of the first battery and the negative terminal of the last battery. This practice helps to balance the battery bank and is called *cross-connecting* the battery bank.

Note: It is not advisable to connect batteries of different case sizes or amp-hour ratings in the same battery bank.

Always use properly sized wire and terminals for your interconnecting battery cables. For size information refer to NEC requirements or contact your local electrician.

BATTERY BANK RATINGS AND SIZING

Deep-cycle batteries are usually rated in amp hours. The amp-hour rating is based on a 20-hour discharge rate. Therefore, a 100 amp-hour battery can deliver 5 amps for 20 hours. If the discharge rate is greater than 5 amps, the available amp hours are decreased. For example, if the load is increased to 100 amps, only about 45 amp hours will be available at this rate of discharge.

Deep-cycle batteries can be discharged about 80% of capacity before damage occurs. Shallow cycling will result in much longer battery life. Calculating a battery bank size based on 50% discharge cycling is generally considered to be a good compromise between long battery life and size.

BATTERIES

To achieve 50% cycling you should calculate your amp-hour consumption between charging cycles and use a battery bank with twice that capacity**. Each AC appliance or tool has a rating plate on it and will be rated in either AC amps or watts or AC VA (volt-amps) apparent power. To calculate amp-hour consumption, use one of the formulas to the right to calculate the DC amp-hour draw for a 12 volt system.

Calculate the amp hours for every AC appliance or tool that will be operated on the inverter. This will provide the total number of amp hours used between recharges. Size the battery bank using this number as a guideline. A good rule to follow is to size the battery bank a minimum of two times larger than the total amp-hour load requirement. Plan on recharging when 50% discharged.

**Batteries are typically charged to 85% of full charge when charging with alternators without three-stage regulators.

AMP-HOUR CONSUMPTION FORMULAS

$$(\text{AC amps} \times 10) \times 1.1 \times \text{hours of operation} = \text{DC amp hours}$$

$$(\text{watts} / \text{DC voltage}) \times 1.1 \times \text{hours of operation} = \text{DC amp hours}$$

$$(\text{AC VA} / \text{DC voltage}) \times 1.1 \times \text{hours of operation} = \text{DC amp hours}$$

DC voltage is 12, 24 or 32, depending on your system.

In all formulas, 1.1 is the correction factor for inverter efficiency.

Typical Power Consumption

The chart identifies typical power consumption for common AC loads. Use it as a guide when identifying your power requirements.

Many electric motors have momentary starting requirements well above their operational rating. Start-up watts are listed where appropriate. Individual styles and brands of appliances may vary.

If using the same battery bank for the inverter and other DC loads, be sure to consider the power consumption of the DC loads when sizing the battery bank.

Typical Power Consumption									
Appliance	Typical Wattage	Appliance Run Times / Amp Hours							
		5 Min.	15 Min.	30 Min.	1 Hr.	2 Hr.	3 Hr.	8 Hr.	24 Hr.
13" Color TV	50	.33	1	2	4	8	12	32	96
19" Color TV	100	.66	2	4	8	16	24	64	192
VCR	50	.33	1	2	4	8	12	32	96
Lamp	100	.66	2	4	8	16	24	64	192
Blender	300	2	6	12					
Laptop Computer	50	.33	1	2	4	8			
Curling Iron	50	.33	1	2					
3/8 Power Drill	500	3.3	10	20					
Icemaker*	200			2.6	5.2	10.4	15.6	41.6	83.2
Coffee Maker	1000	6.6	20	40	80	160			
3 cu' Refrigerator*	150			2	4	8	12	32	96
20 cu' Refrigerator*	750			21	42	84	126	336	672
Compact Microwave	750	5	15	30	60	120	180		
Full Size Microwave	1500	10	30	60	120	240	360		
Vacuum	1100	7.3	22	44	88	176	264		

Number in each box represents the total Amp hours used (@ 12 volt DC) based on various continuous run times.
*Note refrigeration is typically calculated using a 1/3-duty cycle.

NOTE Certain laser printers, breadmakers, digital clocks and appliance/tool chargers may not operate on modified sine wave.

BATTERY CHARGING

Battery Charging

Completely charging wet cell deep-cycle batteries requires the battery voltage to be raised beyond what is known as the gassing point. This is the voltage at which the battery begins to bubble and gas is given off. If charging stops short of this point, sulfate is left on the plates and deterioration of the battery begins. The gassing point will vary with battery temperature.

At 77 °F, the gassing point of a 12-volt battery is about 14.0 volts.

AGM and gel cell batteries must not be charged to their gassing point. In fact, high voltage charging which gasses these batteries is harmful to them. They typically require a lower bulk charge voltage and a higher float voltage than wet cell batteries. Consult the battery manufacturer for specifications.

Fleet Power Battery Chargers

Fleet Power battery chargers are designed to overcome the limitations of conventional chargers by utilizing three distinct charge stages, each designed for optimal charging of wet, gel cell and AGM deep-cycle batteries. Battery type selection is made on the front panel of the inverter/charger or through the Remote Control Panel. For more information on battery type selection, see page 7 or refer to the Remote Control Panel manual.

BATTERY CHARGING

Benefits of the FP3000-12 vs. the traditional taper charger

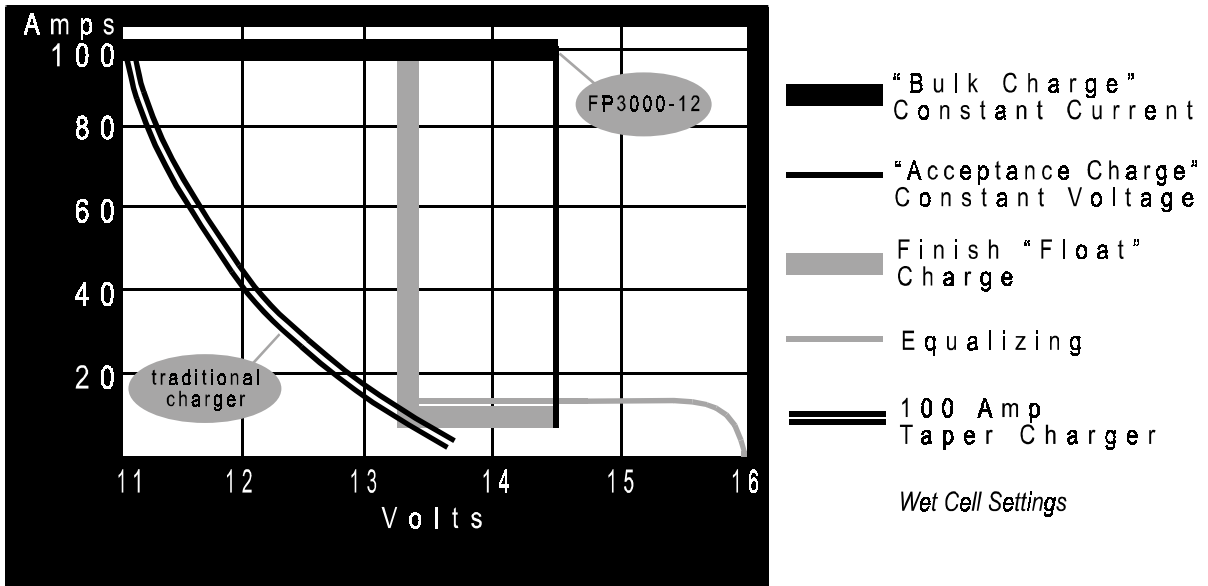

Quicker, more complete recharging, safe long-term charging and battery rejuvenation through an equalizing charge (wet cell settings).

NOTE: The FP3000-12 is ON whenever AC power is connected to the charger input. The charger can be turned OFF using the CHARGE switch on the front of the unit. This sequence will occur each time external AC power is available. The charger can be turned ON/OFF using the Remote Control Panel.

Each time the battery charger is engaged, the three-stage charger proceeds automatically, resulting in an efficient complete charge and safe battery maintenance. Use of the Remote Control Panel provides the ability to periodically apply an equalizing charge.

Refer to Remote Control Panel owner's manual for more information.

The battery charger stages are:

Stage 1 - Bulk Charge During the bulk charge stage most of the energy that has been consumed during discharge is returned to the battery bank. This phase is engaged as soon as the battery charger is activated. Full rated charger current is delivered to the battery bank until the acceptance charge voltage limit is reached. This results in a relatively rapid recharge.

Generally, a wet cell battery bank should not be charged at a rate that exceeds 25% of its capacity.

BATTERY CHARGING

Gel cell and Advanced AGM batteries can accept a higher rate of charge. Consult the manufacturer for specifications.

Stage 2 - Acceptance Charge The acceptance stage immediately follows the bulk charge stage. During this stage the battery voltage is held constant at the bulk charge voltage limit and the current gradually ramps down. During this stage the battery is accepting its final amount of charge current and the last of the sulfate on the plates is removed.

The acceptance stage lasts until the charge current reaches the transition point. A timer will terminate the acceptance stage if this current level is not reached.

ACCEPTANCE TO FLOAT TRANSITION POINT FP3000-12 15 Ampere DC

Maximum acceptance time is one hour for wet and AGM cells and three hours for gel cells. Gel cell acceptance time can be longer because they are less likely to gas. Expect wet cell batteries to gas somewhat during acceptance—this is a necessary part of the charging process.

Stage 3 - Float Charge When the acceptance stage is terminated, either because the charge current ramped down to the transition point or the timer engaged, the charge current will shut off. The unit monitors the battery voltage while it drifts down from the acceptance charge voltage limit. When it reaches the float voltage set point, the float charge stage is engaged.

The float charge stage holds the battery voltage constant at a preset lower level, where it is safe for long-term battery maintenance. During the float charge stage, the full output current of the battery charger is available to operate any DC appliances that may be on the system, while constantly maintaining the float charge voltage.

The battery charger remains in the float charge stage indefinitely until the charger is disconnected from incoming AC power or turned OFF on the unit or with the Remote Control Panel.

Stage 4 - Equalizing Charge This is the only battery charger stage which is not engaged automatically. It must be manually initiated each time. Applying an equalizing charge is possible only with a Remote Control Panel.

Periodic equalizing is recommended by most wet cell deep-cycle battery manufacturers. There are no firm rules for how often an equalizing charge should be applied. Follow the battery manufacturer's recommendations for equalizing.

BATTERY CHARGING

The equalizing charge is a timed, eight-hour cycle. The cycle can be ended early by interrupting the AC power to the charger at any time during the cycle. Equalizing should only be engaged after the batteries have been fully charged by a normal battery charging cycle.

During this equalizing stage, the battery voltage will increase to the equalize voltage. This will cause the battery bank to gas profusely and will accomplish the following:

1. Removal of residual sulfate. Each time a battery is cycled (discharged and charged), a small amount of sulfate is left on the plates. Over time, this gradual buildup of sulfate will compromise the performance of the battery. By applying an equalizing charge, the sulfate is returned back to the electrolyte, raising the specific gravity and fully exposing the active material of the plates.

2. Bring all cells to the same potential. All lead-acid batteries are made up of individual 2-volt cells. As the battery bank is cycled, slight differences in the cells result in different cell voltages, affecting the overall charge effectiveness. Equalizing brings all cells to the same voltage and the electrolyte in each cell to the same specific gravity.

3. Mixing up of the electrolyte. Electrolyte in battery cells tend to separate into layers of acid and water. The vigorous bubbling action of the battery during equalizing serves to physically mix the electrolyte. Refer to the Remote Control Panel owner's manual for additional cautions on equalizing.

Note: Do not equalize gel cell batteries.

BATTERY CHARGING

WARNINGS

1. Do not equalize gel cell batteries.

Check remote default settings.

2. Always monitor the equalize charge cycle. *Provide proper ventilation for battery fumes. Do not allow any sparks during equalizing. If one or more cells begin to overflow, terminate the equalize cycle.*

3. Check the battery electrolyte both before and after the equalizing charge.

Do not expose the battery plates to air. Leave the battery caps on while equalizing. Top off after equalizing.

4. Remove all loads from the DC system before equalizing. *Some DC loads may not tolerate the high charge voltage.*

5. With the Remote Control Panel the battery state-of-charge LEDs sequence during equalizing. *When the equalization cycle is complete, the charge automatically goes to float and the green float LED battery status light is on.*

BATTERY CHARGER VOLTAGE SETTINGS

TEMP		TYPE 0		TYPE 1		TYPE 2		TYPE 3	
		Wet Cell		Gel 1 *		Gel 2 *		AGM	
°F	°C	ACCEPT	FLOAT	ACCEPT	FLOAT	ACCEPT	FLOAT	ACCEPT	FLOAT
120	49	12.5	12.5	13.0	13.0	13.0	13.0	12.9	12.9
110	43	13.6	12.7	13.5	13.0	14.0	13.4	13.9	12.9
100	38	13.8	12.9	13.7	13.2	14.1	13.5	14.0	13.0
90	32	14.0	13.1	13.8	13.3	14.2	13.6	14.1	13.1
80	27	14.2	13.3	14.0	13.5	14.3	13.7	14.2	13.2
70 **	21 **	14.4	13.5	14.1	13.6	14.4	13.8	14.3	13.3
60	16	14.6	13.7	14.3	13.8	14.5	13.9	14.4	13.4
50	10	14.8	13.9	14.4	13.9	14.6	14.0	14.5	13.5
40	5	15.0	14.1	14.6	14.1	14.7	14.1	14.6	13.6
30	-1	15.2	14.3	14.7	14.2	14.8	14.2	14.7	13.7

* There are two gel battery settings. Check with the battery manufacturer to determine the proper setting for your batteries. Usually, Gel 1 is for long battery life; Gel 2 is for rapid charging.

**Default setting when the temperature sensor is not connected.

INSTALLATION PRECAUTIONS

CAUTION This equipment is **not ignition protected** and employs components that can produce arcs or sparks. To reduce the risk of fire or explosions, **do not install in unvented compartments containing batteries or flammable gasses** or areas in which ignition-protected equipment is required.

WARNING

For continued protection against risk of electric shock, use only the ground-fault circuit interrupter (GFCI) type receptacles detailed in this manual. Other types may fail to operate properly when connected to this inverter, resulting in a potential shock hazard.

CAUTION To reduce the risk of electric shock and prevent premature failure due to corrosion, **do not mount where exposed to rain, dripping or spray.**

CAUTION To reduce the risk of fire, do not obstruct ventilation openings. Do not mount in a zero clearance compartment—overheating may result.

CAUTION *Risk of electrical shock. Both AC & DC voltage sources are terminated inside this equipment.* Before servicing, disconnect all inputs and outputs.

Confirm that your shipping carton contains:

- Inverter/Charger
- TSC temperature sensor with 15' cable
- Owner's manual
- Warranty card
- Jumper for AUX Switch (only used without Remote Control Panel)
- Wire nuts

Typical Tools Needed

Flathead and Phillips screwdrivers
Allen (Hex) screwdriver (1/8")
Wrench for connecting battery cables (9/16")
Wire cutters
Wire strippers
Misc. assortment of wire ties and connectors

Accessories Needed for Installation

Fuse - UL Listed DC Rated slow blow fuse as required by NEC.
Electrical wire (10 gauge) for AC input wiring.
Consult NEC for proper size for output wiring.
Battery cables 1-Positive, 1-Negative
Consult NEC for proper size
DC fuse cable
Mounting screws (4)

INSTALLATION

CAUTION *Risk of electrical shock. Do not remove cover, no user serviceable parts inside.* Refer servicing to qualified service personnel.

The FP3000-12 is appropriate for installation in recreational vehicles (RVs), work vehicles, and other applications.

It is recommended that installation be completed by an authorized Xantrex technical dealer or experienced electrician.

Key Installation Points

- 1. The unit is designed to mount horizontally** (on a shelf).
- 2. Allow several inches of clearance** around the unit to permit a supply of fresh air to the cooling fan. Do not block any of the vents or louvers. The thermostat controlled fan pulls air from outside the unit. It pulls air across the internal components, particularly the transformer and heat sinks, then out the fan vent.
- 3. Keep the inverter/charger out of the elements and out of direct contact with water or spray.** Failure to do so may result in premature malfunction from corrosion and void the warranty.
- 4. Mount the unit as close to the batteries as possible** but not in the presence of flammable fumes or in an enclosed battery compartment.

WARNING

Do not mount the unit in an enclosed battery compartment. Take precautions to keep dirt and spray off the unit.

5. Keep the overall length of each battery cable less than 10 feet. Do not use frame ground or a ground bonding system as a current-carrying conductor. Run the negative (-) cable directly to the battery bank. If the positive (+) and negative (-) cables run parallel to each other, twist the cables together. This will minimize the inductive adverse effects of cable length. Be sure the cable size meets with NEC requirements for your installation.

6. Make sure all wiring conforms to local and national electrical codes. If in doubt, consult with a qualified electrician.

7. To meet electrical codes, a UL Listed DC Rated slow blow fuse must be installed in the positive battery cable within 18 inches of the battery post. This fuse is intended to protect the battery and cables against a short circuit. The inverter is protected internally and will not blow a properly sized fuse.

8. Do not connect the battery until you have read the remainder of the installation section. Observe proper polarity when connecting batteries. Reverse DC polarity will result in damage to the unit and will void the warranty. Use care when making the DC connections.

WARNING

The FP3000-12 is not DC reverse polarity protected. Be very careful to connect the negative and positive cables correctly, otherwise damage will result and the warranty will be void.

INSTALLATION

9. Do not backfeed the AC output of the inverter with incoming AC power. A backfeed occurs when AC power from shorepower or generator is connected to the output of the inverter. This will damage the inverter and void the warranty. Remember that incoming AC must be fed only to the AC input and never the AC output. Always check for AC voltage before connecting wires to the AC output. Do NOT turn the inverter ON until all AC connections have been made. Backfeeding the inverter voids the warranty.

WARNING

Do not connect incoming AC from any source to the AC output of the inverter. This is known as backfeeding and will damage the unit and void the warranty.

10. Do not connect the AC input to the AC output. This would be equivalent to plugging the battery charger into the inverter. This could occur if the unit's AC output is connected to the entire leg of a circuit breaker panel, then a circuit breaker on that leg is used to feed the battery charger input. This will cause the unit to oscillate ON and OFF when the unit is in inverter mode.

11. Always use proper wire and connectors. The proper battery cable size is critical. Considerable amperage flows in the DC circuit. For the FP3000-12, use 3/0 AWG UL Listed Welding Cable terminated on each with UL Listed or UL Recognized ring terminal connectors. For the terminal, use Thomas & Betts (T&B) part number BAL 2038. Be sure the connectors are attached to the cable using a method approved by the connector manufacturer. For the connections to meet all requirements, T&B recommends that each terminal be crimped in two places with a pressure of 15

tons using a hexagonal die. The T&B die has a code number of 54. After the crimp is made, the barrel of the terminal and the first inch of the cable needs to be covered in UL Listed or UL Recognized heat shrink tubing. Xantrex recommends a 2-inch length of 3M HDT 0800 tubing. Other heat shrink may be used if it is UL Listed or UL Recognized as long as the manufacturer's directions are followed.

12. If installing in a system which includes an existing battery charger or AC to DC converter, **make sure these do not operate from the inverter output AC power.** This sets up a power loop which, due to inefficiencies, will quickly drain the batteries.

13. An Auxiliary Switch port is located on the front panel of the unit, covered by a flap. When installing the unit for operation without a Remote Control Panel, a jumper must be installed in the Aux Switch port. The jumper is shipped in a plastic bag with other installation parts. DO NOT install the jumper until all cable connections have been made.

When using a Remote Control Panel, the jumper is not used.

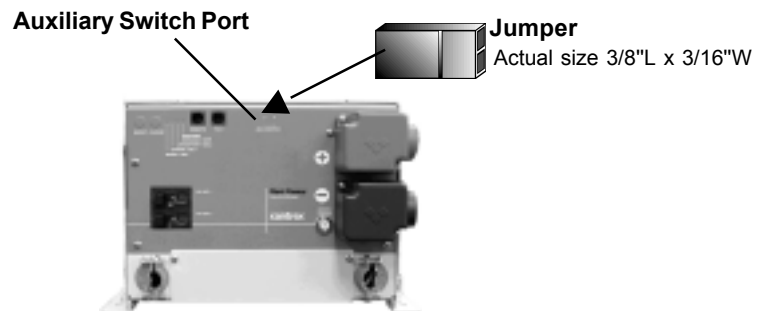

INSTALLATION

Grounding

For safety purposes, the chassis of the inverter/charger must be connected to your AC ground system. Use 8 AWG bare copper or green insulated wire, strip one end and use a screwdriver to secure it to the chassis ground bonding lug on the side of the unit. This wire will connect to the ground in your AC electrical system. Make sure the connection is clean and tight.

The system AC ground bonding terminal is located on the front of the unit under the wiring cover at the bottom of the unit. This connector is for the bare copper or green ground wires from the AC branch circuit supply and to the AC loads or distribution panel. It is important that these AC input and AC output ground wires connect to the AC ground bus in the circuit breaker panels.

Some installations require heavier grounding wire. Conform to local and national electrical codes.

More information on grounding can be found in the National Electrical Code and local electrical codes.

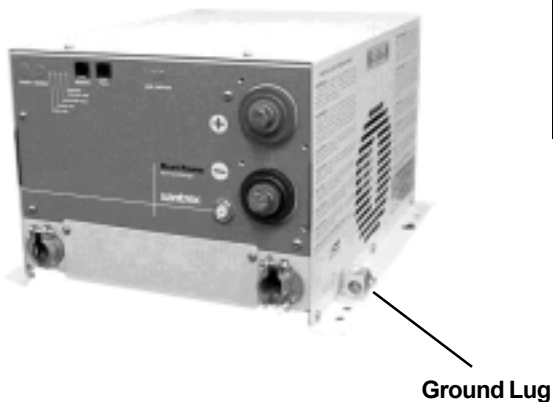

Note: The battery cables are not connected to the AC ground strip or to the chassis lug of the unit.

Neutral Bonding

For safety purposes and NEC code requirements, the FP3000-12 unit internally bonds the AC output neutral (white) to the AC output ground (green), when the unit is OFF or in the inverter mode. When incoming AC power is applied and the transfer switch is engaged, the internal neutral-to-ground bond is automatically lifted.

When external AC power is applied, the grounding system is connected to the source power ground, where neutral and earth ground are bonded together. This technique ensures safety in all conditions and conforms to the requirements of the NEC.

WARNING

Do not connect incoming AC from any source to the AC output of the inverter/charger. This is known as backfeeding and will damage the unit and void the warranty. The Over Temp/Overload and Low Battery LEDs will be blinking rapidly if this condition exists.

INSTALLATION

AC Wiring

The AC wires route through the strain relief mounted in holes on the front of the unit. Use a screwdriver to remove the screws which secure the AC wiring compartment cover plate. The labeling for the pigtails is on the front of the unit and is visible when the cover plate is removed. Note: green wires are connected to the AC ground strip.

Black **Hot or Line**
White **Neutral**

Conventional metal strain reliefs are provided. These can be replaced with plastic strain reliefs for additional corrosion resistance or 3/4-inch conduit fittings if the wiring will be routed through a conduit.

Appropriate wire gauges must be used throughout the installation. Refer to NEC specifications.

AC Input: All inputs from other AC sources must be protected by branch circuit rated circuit breakers.

In the United States, no additional circuit breakers are required between the inverter/charger and the loads if the service to the inverter/charger is protected by a 20 ampere branch circuit rated breaker. This also applies to dual input models where the inputs may be 20 amperes each. In Canada, 15 ampere branch circuit(s) maximum shall provide the service.

If a 30 ampere service supplies the inverter/charger, additional 20 ampere (15 ampere in Canada) maximum branch circuit rated circuit breakers will be required between the inverter/charger and the loads.

Feed one or two three-conductor AC input wire(s) through the strain relief and into the AC

wiring compartment. Allow 6 inches of individual insulated black, white and green wire to work with. Strip 1/2 inch of insulation off each conductor and connect to the pigtails: black to black, white to white, and green to AC ground strip.

Use the wire nuts provided to make the wire connections. You may choose to use butt splices (not included) to make the wire connections.

AC Output: Depending on the model you have, feed one or two three-conductor AC output wire groups for the two branch circuit loads through its strain relief. Remember to allow 6 inches of individual insulated black, white and green wire to work with. Strip 1/2 inch of insulation off each conductor and connect to the pigtails: black to black, white to white, and green to AC ground strip.

Tug firmly on each connection to make sure they are secure. Later, if the unit is not operating properly, check these connections first. Carefully tuck the wires into the AC wiring compartment. Replace the cover plate.

Dual AC Output

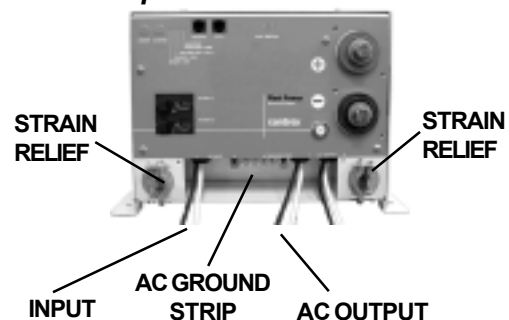

INSTALLATION

Ground Fault Circuit Interrupters

To conform to NEC regulations, certain branch circuits must be equipped with a Ground Fault Circuit Interrupter (GFCI). Please consult the code or a qualified electrician for details. Any such branch circuits must be protected by a brand rated circuit breaker consistent with the GFCI rating. Underwriters Laboratories has tested the following GFCI, and its use is recommended. Receptacle Type:

Pass & Seymour
Catalog Number 1591
Rated: 15 Amps at 120 Volts AC

Remote Control Wiring

If installing a remote panel, route the remote cable and connect to the Remote jack on the front of the unit. Refer to the Remote Control Panel Owner's Manual for more information.

TSC Temperature Sensor

If installing the TSC (Temperature Sensitive Charging) sensor, connect the ring terminal end to the positive battery post, complete the routing of the RJ11 cable (15 feet supplied) and connect the plug end to the TSC jack on the front of the unit.

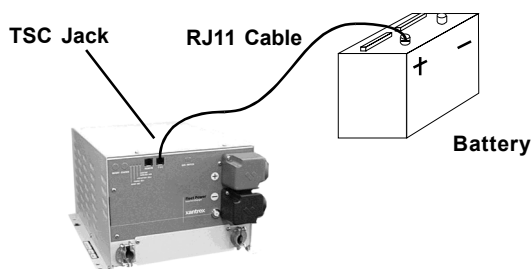

DC Wiring

DC wiring is generally very simple—the positive (+, may be red for identification) and negative (-, may be black or yellow for identification) cables from the inverter/charger terminal posts are connected to the house or auxiliary battery. Connection to the engine starter battery is not recommended.

High current will pass through the DC wiring. All wires must be properly sized and all connections clean and tight. It is recommended that the battery cable length does not exceed 10 feet.

Battery cables should be connected to the inverter/charger before any connections are made to the battery. Follow the battery hardware stackup diagram.

- Remove the negative (-) battery cable cover from the unit and attach the battery cable. Tighten the battery terminal bolts to a torque value between 160 inch-pounds and 180 inch-pounds. Replace the cover for the negative terminal before removing the cover for the positive terminal.

Battery Cable Hardware Stackup Diagram

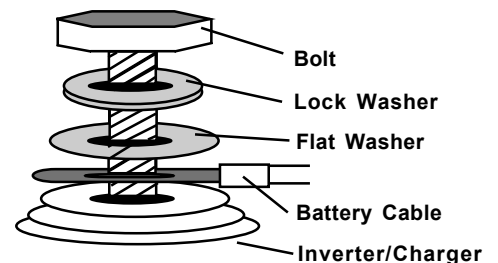

CAUTION Improper stackup may result in excessive heat and damage to the unit.

WARNING

The FP3000-12 is not protected against DC reverse polarity. Be very careful to connect the negative and positive cables correctly or damage will result and the warranty will be void.

INSTALLATION

- Remove the positive (+) battery cable terminal cover from the unit and attach the battery cable. Tighten the battery terminal bolts to a torque value between 160 inch-pounds and 180 inch-pounds. Replace the cover for the positive terminal.

The negative (-) cable should be connected directly to the negative post of the house or auxiliary battery bank or the ground side of a current shunt. Tighten securely.

The positive (+) battery cable must be fused and connected to the positive post of the house or auxiliary battery bank, or through a selector switch to one or more battery banks.

A spark may be generated when the final battery connection is made. This is normal; do not be alarmed. However, do not make the final connection in the presence of flammable fumes.

If multiple batteries are used, the interconnecting jumper cables must be the same AWG or larger as those connected to the inverter/charger.

NOTE: If installing in a vehicle, do not use the vehicle frame as the negative conductor.

If multiple battery banks are to be charged, a battery bank selector switch can be installed, allowing the banks to be charged either individually or simultaneously. A solenoid can also be used.

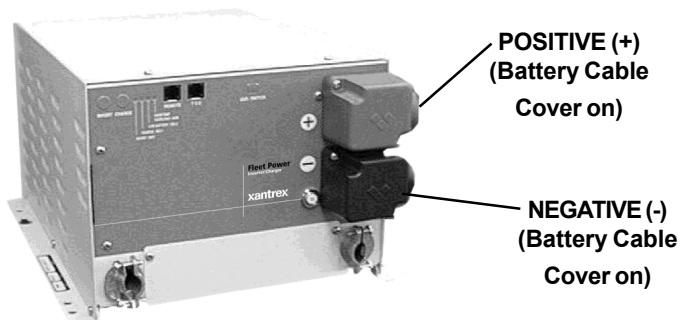

INSTALLATION

Battery Cable Fusing

A fuse is required by the NEC to protect the battery and cables. A UL Listed DC rated slow blow fuse must be installed in the positive (+) battery cable, within 18 inches of the battery.

Recommended Fuse: *UL Listed Class T JLLN* with a DC Rating. This fuse with fuse holder is available from your dealer.

For the FP3000-12

350 Amp Fuse & Holder PN# 84-4159-00

350 Amp Fuse Only PN# 84-4152-00

HARDWARE STACK-UP OPTIONS

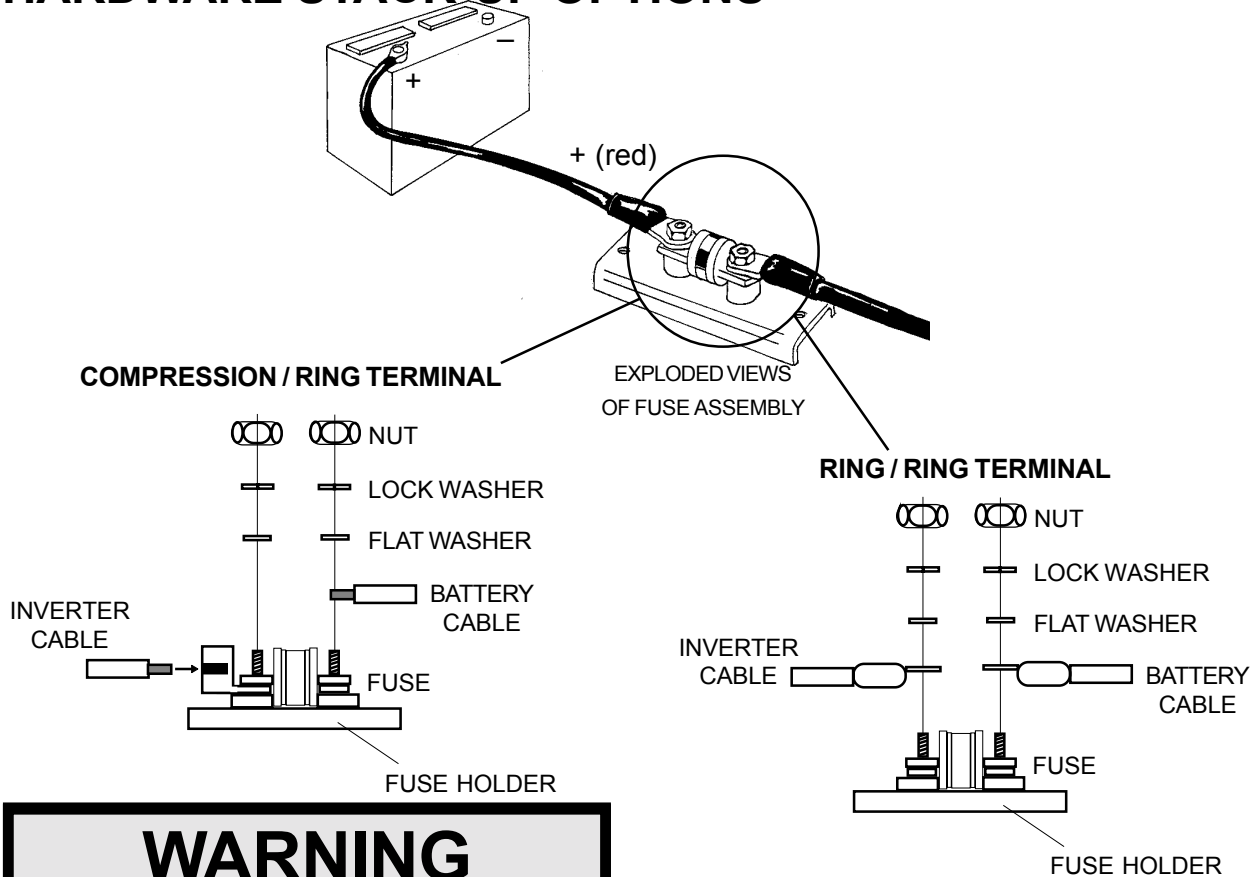

INSTALLATION

Follow these instructions to ensure proper startup and confirm that the installation is correct.

1. Check to make sure Invert and Charge are OFF. The INVERT LED should not be illuminated, the CHARGE LED should be blinking (charger ready but no external AC power available). If using a Remote Control Panel, make sure inverter and charger are OFF.
2. Check battery polarity. If the unit was connected to the battery with reverse polarity, the unit will be damaged.
3. Check the battery voltage and ensure it is within proper range for the unit (10–15.5 VDC).
4. Install the jumper in the Auxiliary Switch port (AUX SWITCH), if using the inverter without remote. If operating the inverter with a remote, the jumper should **not** be used.

Do not apply shorepower or generator power without performing the following steps:

1. Test the inverter function:

- With no loads connected to the output of the inverter, turn the INVERT Switch ON. The INVERT LED should be blinking green. If using a remote, turn ON the inverter with the switch on the Remote Control Panel.

- The FP3000-12 will produce a slight buzz. If using a Remote Control Panel, the INVERT/CHARGE LEDs will illuminate and the voltage indicator will display the battery voltage. The DC Amps LED will not be lit because the unit is in the idle mode.

WARNING

Do not turn the inverter ON before eliminating any possibility of backfeed.

- Add a load of 7 watts or more to the output of the inverter. A 40-watt incandescent light bulb will work fine. The DC Amps LEDs on the remote will indicate the DC draw from the battery through the inverter.

- Leave the load connected and turn OFF the INVERT mode by pressing the INVERT switch or turn OFF the INVERT mode from the Remote Control Panel.

2. Test the transfer function:

- Be sure the unit is OFF, the INVERT and CHARGE LEDs are not illuminated. Apply shorepower. If there is a backfeed in the installation, the unit will protect itself, the LOW BATTERY and OVERTEMP/OVERLOAD LED will both be blinking rapidly (five times per second). Do not proceed until the backfeed condition has been corrected.

- Once shorepower has been applied to the unit, there will be approximately an eight-second delay. Then the unit should transfer shorepower and power the load. If this does not happen, do not proceed. If the LOW BATTERY and OVERLOAD/OVERTEMP LEDs are blinking rapidly or if you are using a Remote Control Panel, check the panel for backfeed indication. The panel will show an overload condition. Eliminate the backfeed condition.

INSTALLATION

- Testing for backfeed. If a backfeed condition is indicated, disconnect from shorepower and disconnect the AC output wires on the inverter. Make sure the inverter is OFF. Apply shorepower and measure for voltage between the black and white wires that were attached to the inverter output feeding the electrical panel or loads, not the inverter output wires. If there is voltage on these wires, a backfeed condition exists and must be corrected or damage will result.

3. Test the battery charger function:

- With shorepower applied and the transfer switch engaged, the battery charger should be in operation. The CHARGE LED will blink for eight seconds. After the eight seconds, the unit will enter the charge mode and the LED will be illuminated. (NOTE: When using Temperature Sensitive Charging, this time may be longer.)

NOTE: When AC is available, the unit will automatically default to charge mode without the operator setting the unit in CHARGE mode. If you do not want to charge, it is necessary to press the CHARGE switch OFF.

Verify the charger is working by using a voltmeter. The battery voltage should gradually increase. If using a Remote Control Panel, the DC Amps LED indicates the current the charger is putting out and the DC Volts LED indicates an increase in battery voltage.

- Turn the INVERT ON—the green LED should blink. Remove shorepower and the inverter should automatically pick up the AC load.

NOTE: For low power system shut down mode, both the INVERT and CHARGE LEDs must be OFF.

Repeat the test for transfer and battery charger with the generator if you have one.

Congratulations, you have completed a successful installation.

TROUBLESHOOTING LED STATUS

LED Status				Operation Status	Notes
INVERT	CHARGE	LOW BATTERY	OVERTEMP OVERLOAD		
Solid Green	Blinking Green	OFF	OFF	Inverting. Charger ready but no external AC available.	Normal
Blinking Green	Solid Green	OFF	OFF	Inverter is in standby. Battery is being charged.	Normal, charging current limited if AC load exceeds Power Sharing setting.
Blinking Green	OFF	OFF	OFF	Inverter is in standby. Charger manually turned off.	If AC power is removed and reapplied, the charger will automatically turn ON.
OFF	Solid Green	OFF	OFF	Inverter OFF. Charging.	Reset the inverter by pushing INVERT button. LED should blink.
Solid Green	Blinking Green	Solid Red	*	Inverting. Charger ready but no external AC available. Battery Voltage Warning: $10V < VDC < 15V$	Warning. Battery voltage less than 10 or more than 15 volts
Solid Green	Blinking Green	*	Solid Red	Inverting. Charger ready but no external AC available. Over-temperature Warning	Warning. Inverter shutdown.
OFF	Blinking Green	Slow Blinking Red	*	Battery Voltage shutdown: $10V < VDC > 15V$	Inverter Shutdown. Operation will resume when battery reaches 13.5 volts
OFF	Blinking Green	*	Slow Blinking Red	Charger ready but no external AC power available. Charger over-temperature Shutdown	Operation will automatically resume after unit has cooled down
OFF	Blinking Green	*	Fast Blinking Red	Inverter Overload Shutdown	Reduce AC load. Manually restart the system
OFF	Blinking Green	Fast Blinking Red	Fast Blinking Red	Backfeed Shutdown. Incorrect AC wiring	Correct AC in wiring before use. Manually restart the system.
OFF	Blinking Green	Fast Blinking Red	OFF	Battery Ripple	Warning

* Could be either ON or OFF status.

page intentionally blank.

GLOSSARY

Alternating Current (AC) An electric current that reverses direction at regular intervals. Sources of alternating current are shorepower, generator power, inverter power or household current.

Ampere (amp, A) The unit of measure of electron flow rate of current through a circuit.

Amp hour (Amp-Hr., Ah) A unit of measure for a battery's electrical storage capacity, obtained by multiplying the current in amperes by the time in hours of discharge. (Example: a battery which delivers 5 amperes for 20 hours delivers 5 amperes times 20 hours, or 100 amp hours of capacity.)

Amp-Hour Capacity The ability of a fully charged battery to deliver a specified quantity of electricity (Amp-Hr., Ah) at a given rate (amp, A) over a definite period of time (Hr.). The capacity of a battery depends upon a number of factors such as: active material, weight, density, adhesion to grid, number, design and dimensions of plates, plate spacing design of separators, specific gravity and quantity of available electrolyte, grid alloys, final limiting voltage, discharge rate, temperature, internal and external resistance, age and life of the battery (bank).

AGM (Absorbed Glass Mat) Battery A lead acid, maintenance-free battery.

AWG (American Wire Gauge) A standard used to measure the size of wire.

Circuit An electric circuit is the path of an electric current. A closed circuit has a complete path. An open circuit has a broken or disconnected path.

Circuit (Series) A circuit which has only one path for the current to flow. Batteries arranged in series are connected with the negative of the

first to the positive of the second, negative of the second to the positive of the third, etc. If two 6-volt batteries of 50 amp-hours capacity are connected in series, the circuit voltage is equal to the sum of the two battery voltages, or 12 volts, and the amp-hour capacity of the combination is 50 amp hours.

Circuit (Parallel) A circuit which provides more than one path for current flow. A parallel arrangement of batteries (of like voltage and capacity) would have all positive terminals connected to a conductor and all negative terminals connected to another conductor. If two 12-volt batteries of 50 amp-hour capacity each are connected in parallel, the circuit voltage is 12 volts, and the amp-hour capacity of the combination is 100 amp hours.

Current The rate of flow of electricity or the movement rate of electrons along a conductor. It is comparable to the flow of a stream of water. The unit of measure for current is ampere.

Cycle In a battery, one discharge plus one recharge equals one cycle.

Direct Current (DC) Current that flows continuously in one direction such as that from batteries, photovoltaics, alternators, chargers and DC generators.

Equalize Charge A controlled overcharge of the batteries which brings all cells up to the same voltage potential, extends the battery life, restores capacity and mixes the electrolyte. This can only be done using the Remote Control Panel.

Gel Cell Battery A type of battery that uses a gelled electrolyte solution. These batteries are sealed and are virtually maintenance free. Not all sealed batteries are the gel cell type.

GLOSSARY

GFCI (Ground Fault Circuit Interrupter) A protective device that rapidly de-energizes a circuit when current to ground exceeds a predetermined value.

Ground The reference potential of a circuit. In automotive use, the result of attaching one battery cable to the body or frame which is used as a path for completing a circuit in lieu of a direct wire from a component. This method is not suitable for connecting the negative cable of the inverter to ground. Instead, route the cable directly to the negative terminal of the battery.

LED (Light Emitting Diode) Indicator light.

NEC National Electric Code

Negative Designating or pertaining to electrical potential. The negative terminal is the point from which electrons flow during discharge.

Ohm A unit for measuring electrical resistance.

Ohm's Law Expresses the relationship between voltage (V) and current (I) in an electrical circuit with resistance (R). It can be expressed as follows: $V=IR$. If any two of the three values are known, the third value can be calculated by using the above formula.

Positive Designating or pertaining to electrical potential; opposite of negative. The positive battery terminal is the point where electrons return to the battery during discharge.

Power Sharing The feature of the charger to reduce its output when the AC power being consumed by the charger and external AC loads connected to the output of the inverter are in excess of the input breaker rating.

TSC Abbreviation for Temperature Sensitive Charging. The ability of the charger to adjust its charging voltage based on the temperature sensed at the battery bank if a temperature probe is used.

Volt The unit of measure for electric potential.

Watt The unit for measuring electrical power, i.e., the rate of doing work, in moving electrons by or against an electric potential.

Watt-Hour (Watt-HR, WH) The unit for measuring electrical energy which equals watts x hours.

Wet Cell Battery A type of battery that uses liquid as an electrolyte. The wet cell battery requires periodic maintenance: cleaning the connections, checking the electrolyte level and performing an equalization cycle.

SPECIFICATIONS

Fleet Power 3000-12

Nominal Battery Charge	12 VDC
Battery Voltage Range	10.0 to 15.5 VDC
Low Battery Cutout	10.0 VDC (+/- 0.5)
AC Input Voltage Range	Minimum 90 VAC/Normal 130 VAC
Frequency Regulation	50 or 60 Hz Quartz Regulated
Inverter Output Power (Continuous)	3000 VA
Inverter Voltage Regulation	120 V +/- 5% true RMS
Wave Shape	Modified Sine Wave
Surge Power	75 amps
No Load Current Drain (Idle Mode)	.12 amps
Power Factors Allowed	All
Full Load Efficiency	86% (60 Hz)
Peak Efficiency	93%
Protection	Over/under utility voltage, over/under battery voltage, short circuit, circuit breaker, over temperature, backfeed
Charging Rate	140 amps (three stage)
AC Input (Max. Charge Mode)	28 amps
Bulk Charge Voltage	14.3 VDC*
Float Charge Voltage	13.4 VDC*
Equalizing Charge Voltage	16.3 VDC*
Status Panel	Optional remote
Weight	50 lbs.
Dimensions	13.2" L x 11.5" W x 7.9" H

*variable on unit with Temperature Sensor installed and adjustable by Battery Type selected on the inverter/charger control panel or from the Remote Control Panel.



page intentionally blank.

INSTALLATION

Installation examples for the FP3000-12

The following installation examples are the most commonly used applications involving specific shorepower connections, generator power options, and AC load configurations.

Shorepower configurations:

Systems with one 30 amp single-phase shorepower source with optional generator.

Systems with two 30-amp shorepower sources with optional generator.

Systems with a 50-amp 120-volt single-phase (three wire) shorepower source with optional generator.

Systems with a 50-amp 120/240 volt split-phase (four wire) shorepower source with optional generator.

Inverter/charger configuration:

Single input/single output

FP3000-12 DC Cable and Fuse General Guide

Fuse size:	350 A
Typical DC amps:	300 A
Cable AWG by length*:	1 to 3 ft.—3/0
	3 to 6 ft.—3/0
	6 to 10 ft.—4/0

*This guide is intended to provide general recommendations for fuse and cable sizing. Always consult local and national electrical codes for proper fuse and cable size prior to installation.

The chassis grounding wire must be no smaller than 1 gauge under that of the positive battery cable.

INSTALLATION OPTIONS

Installation Option #1

The inverter is used in a Single Input/Single Output mode. Up to 30 amps is transferred through the FP3000-12 with the charger sharing power with all of the AC loads.

In this installation example, a single 30-amp shorepower source is available and all AC loads are supplied power through the inverter in charge/transfer mode, or by the inverter in invert mode. The charger shares power with the AC loads and can transfer up to 30 amps. The AC input power must be supplied through a 30-amp branch rated main breaker.

In this type of system, the panel loads would normally not include any heavy loads such as space heaters, stove, water heaters, air conditioners, AC to DC converters, or other battery chargers. If these types of loads are present, they should be turned OFF when the inverter power is being used to prevent overloading the inverter or rapidly discharging the battery bank. To avoid the need for this manual form of energy management, installation option #2 should be considered.

If a generator is installed in the system, a break-before-make AC transfer switch is used to select between shore or generator power. The transfer switch AC output is then routed to the input of the inverter/charger.

FP3000-12 Installation Option 1

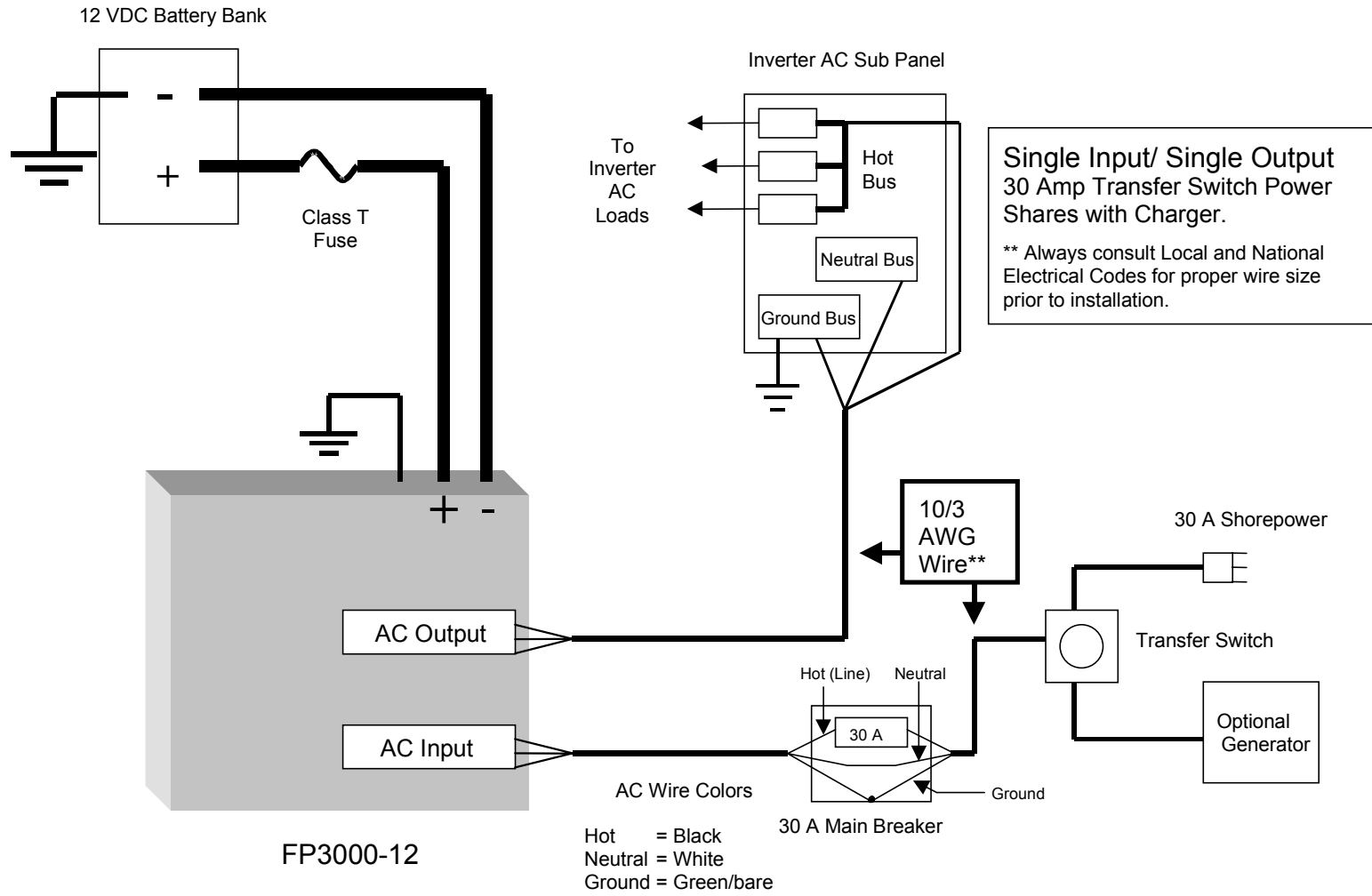

INSTALLATION OPTIONS

INSTALLATION OPTIONS

Installation Option #2

The AC loads are split between main loads and “inverter loads.” The external sources of AC power can be a single 30-amp shorepower source or a 30-amp breaker from a panel fed by a 50-amp 120 volt single phase (three wire) shorepower source, 1 leg of a 50-amp 120/240 split phase (four wire) shorepower source, or a generator. The charter shares power with the “inverter loads” only.

In this installation example, one single-phase shorepower source is available or only one leg of a split-phase source is used to supply the AC input of the inverter/charger. It is highly recommended that only the lighter appliance and outlet circuits be connected to the inverter AC panel. These loads are supplied power through the inverter in charge/transfer mode, or by the inverter in invert mode. The charger shares power with the “inverter loads” only and can transfer up to 30 amps. The heavier loads such as space heaters, stove, water heater, air conditioners, AC to DC converters, or other battery chargers, should remain connected to the main AC panel. These loads are only supplied by shore or generator power from the main panel. This split load approach will help avoid problems such as overloading the inverter or rapidly discharging the battery bank, and eliminate the need to manually manage the energy usage of these loads when using inverter power.

The inverter AC input must be supplied power from a 30-amp breaker in the main panel and from the main neutral bus. The inverter’s AC output supplies a separate sub panel. The appliance and outlet loads are then supplied with power from the inverter hot and neutral bus in the sub panel.

If a generator is installed in the system, a break-before-make AC transfer switch is used to select between shore or generator power. The transfer switch AC output is then routed to the input of the main AC panel.

FP3000-12 Installation Option 2

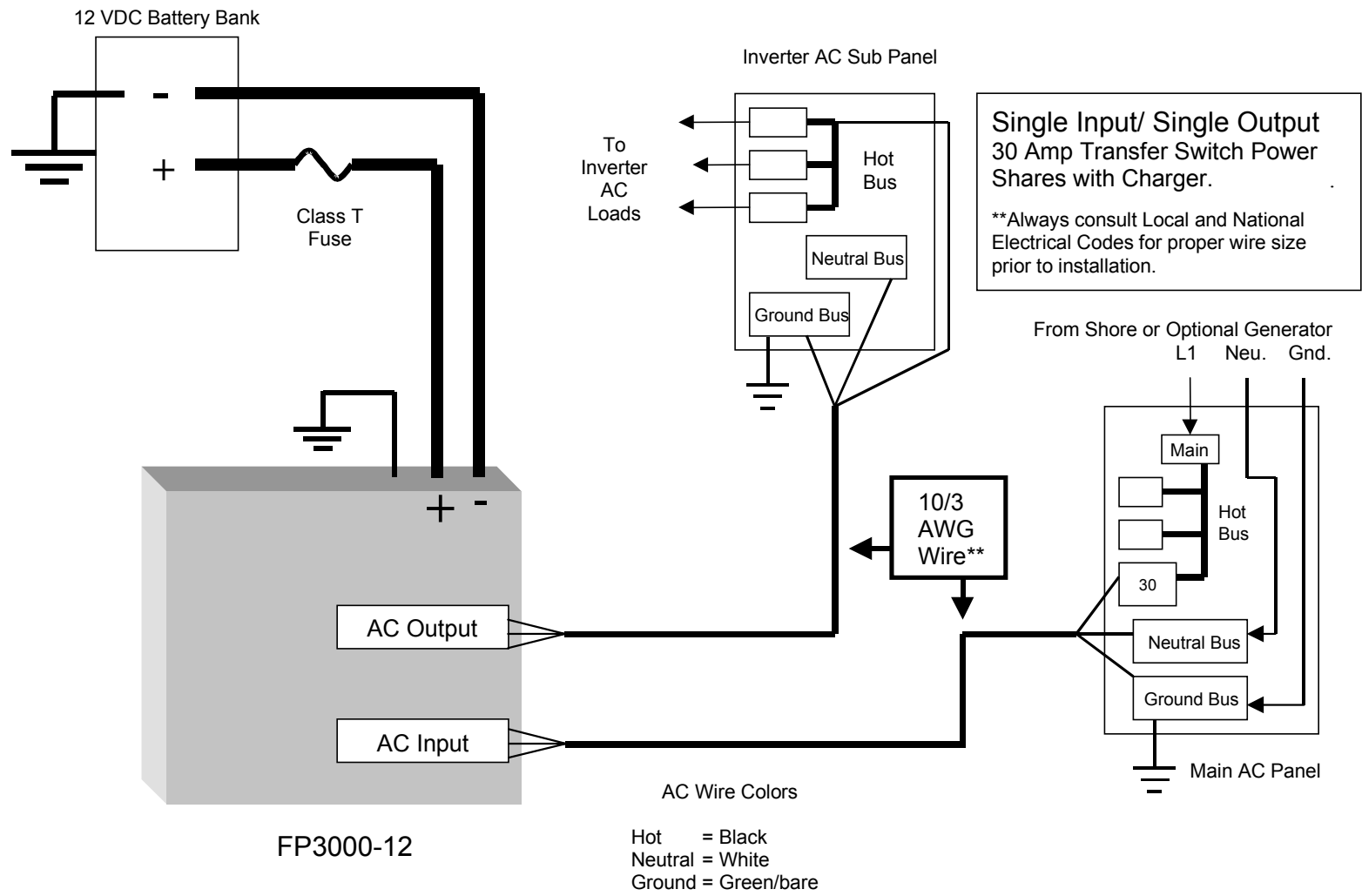

INSTALLATION OPTIONS



page intentionally blank.

WARRANTY

What does this warranty cover? This Limited Warranty is provided by Xantrex Technology, Inc. (“Xantrex”) and covers defects in workmanship and materials in your Xantrex Fleet Power 3000-12 Inverter/Charger. This warranty lasts for a Warranty Period of one year from the date of purchase at point of sale to you, the original end user customer.

This Limited Warranty is transferable to subsequent owners but only for the unexpired portion of the Warranty Period.

What will Xantrex do? Xantrex will, at its option, repair or replace the defective product free of charge, provided that you notify Xantrex of the product defect within the Warranty Period, and provided that Xantrex through inspection establishes the existence of such a defect and that it is covered by this Limited Warranty.

Xantrex will, at its option, use new and/or reconditioned parts in performing warranty repair and building replacement products. Xantrex reserves the right to use parts or products of original or improved design in the repair or replacement. If Xantrex repairs or replaces a product, its warranty continues for the remaining portion of the original Warranty Period or 90 days from the date of the return shipment to the customer, whichever is greater. All replaced products and all parts removed from repaired products become the property of Xantrex.

Xantrex covers both parts and labor necessary to repair the product, and return shipment to the customer via a Xantrex-selected non-expedited surface freight within the contiguous United States and Canada. Alaska and Hawaii are excluded. Contact Xantrex Customer Service for details on freight policy for return shipments outside of the contiguous United States and Canada.

How do you get service? If your product requires troubleshooting or warranty service, contact your merchant. If you are unable to contact your merchant, or the merchant is unable to provide service, contact Xantrex directly at:

Phone: 1-800-670-0707 (toll free in North America) 1-604-422-2777 (direct)

Fax: 1-604-420-2145

Email: CustomerService@xantrex.com

Direct returns may be performed according to the Xantrex Return Material Authorization Policy described in your product manual. For some products, Xantrex maintains a network of regional Authorized Service Centers. Call Xantrex or check our Web site to see if your product can be repaired at one of these facilities.

In any warranty claim, dated proof of purchase must accompany the product, and the product must not have been disassembled or modified without prior written authorization from Xantrex.

Proof of purchase may be in any one of the following forms:

- The dated purchase receipt from the original purchase of the product at point of sale to the end user, or
- The dated dealer invoice or purchase receipt showing original equipment manufacturer (OEM) status, or
- The dated invoice or purchase receipt showing the product exchanged under warranty

WARRANTY

What does this warranty not cover? This Limited Warranty does not cover normal wear and tear of the product or costs related to the removal, installation, or troubleshooting of the customer's electrical systems. This warranty does not apply to and Xantrex will not be responsible for any defect in or damage to:

- a) the product if it has been misused, neglected, improperly installed, physically damaged or altered, either internally or externally, or damaged from improper use or use in an unsuitable environment;
- b) the product if it has been subjected to fire, water, generalized corrosion, biological infestations, or input voltage that creates operating conditions beyond the maximum or minimum limits listed in the Xantrex product specifications including high input voltage from generators and lightning strikes;
- c) the product if repairs have been done to it other than by Xantrex or its authorized service centers (hereafter "ASCs");
- d) the product if it is used as a component part of a product expressly warranted by another manufacturer;
- e) the product if its original identification (trademark, serial number) markings have been defaced, altered, or removed.

Disclaimer

Product

THIS LIMITED WARRANTY IS THE SOLE AND EXCLUSIVE WARRANTY PROVIDED BY XANTREX IN CONNECTION WITH YOUR XANTREX PRODUCT AND IS, WHERE PERMITTED BY LAW, IN LIEU OF ALL OTHER WARRANTIES, CONDITIONS, GUARANTEES, REPRESENTATIONS, OBLIGATIONS AND LIABILITIES, EXPRESS OR IMPLIED, STATUTORY OR OTHERWISE IN CONNECTION WITH THE PRODUCT, HOWEVER ARISING (WHETHER BY CONTRACT, TORT, NEGLIGENCE, PRINCIPLES OF MANUFACTURER'S LIABILITY, OPERATION OF LAW, CONDUCT, STATEMENT OR OTHERWISE), INCLUDING WITHOUT RESTRICTION ANY IMPLIED WARRANTY OR CONDITION OF QUALITY, MERCHANTABILITY OR FITNESS FOR A PARTICULAR PURPOSE. ANY IMPLIED WARRANTY OF MERCHANTABILITY OR FITNESS FOR A PARTICULAR PURPOSE TO THE EXTENT REQUIRED UNDER APPLICABLE LAW TO APPLY TO THE PRODUCT SHALL BE LIMITED IN DURATION TO THE PERIOD STIPULATED UNDER THIS LIMITED WARRANTY.

IN NO EVENT WILL XANTREX BE LIABLE FOR ANY SPECIAL, DIRECT, INDIRECT, INCIDENTAL OR CONSEQUENTIAL DAMAGES, LOSSES, COSTS OR EXPENSES HOWEVER ARISING WHETHER IN CONTRACT OR TORT INCLUDING WITHOUT RESTRICTION ANY ECONOMIC LOSSES OF ANY KIND, ANY LOSS OR DAMAGE TO PROPERTY, ANY PERSONAL INJURY, ANY DAMAGE OR INJURY ARISING FROM OR AS A RESULT OF MISUSE OR ABUSE, OR THE INCORRECT INSTALLATION, INTEGRATION OR OPERATION OF THE PRODUCT.

Exclusions

If this product is a consumer product, federal law does not allow an exclusion of implied warranties. To the extent you are entitled to implied warranties under federal law, to the extent permitted by applicable law they are limited to the duration of this Limited Warranty. Some states and provinces do not allow limitations or exclusions on implied warranties or on the duration of an implied warranty or on the limitation or exclusion of incidental or consequential damages, so the above limitation(s) or exclusion(s) may not apply to you. This Limited Warranty gives you specific legal rights. You may have other rights which may vary from state to state or province to province.

WARRANTY

Warning: Limitations On Use

Please refer to your product user manual for limitations on uses of the product. Specifically, please note that the Xantrex Fleet Power 3000-12 is not intended for use in connection with life support systems, and Xantrex makes no warranty or representation in connection with any use of the product for such purposes.

Please note that the Fleet Power 3000-12 is not intended for use as an uninterruptible power supply and Xantrex makes no warranty or representation in connection with any use of the product for such purposes.

Return Material Authorization Policy

Before returning a product directly to Xantrex you must obtain a Return Material Authorization (RMA) number and the correct factory “Ship To” address. Products must also be shipped prepaid. Product shipments will be refused and returned at your expense if they are unauthorized, returned without an RMA number clearly marked on the outside of the shipping box, if they are shipped collect, or if they are shipped to the wrong location.

When you contact Xantrex to obtain service, please have your instruction manual ready for reference and be prepared to supply:

- The serial number of your product
- Information about the installation and use of the unit
- Information about the failure and/or reason for the return
- A copy of your dated proof of purchase

Return Procedure

1. Package the unit safely, preferably using the original box and packing materials. Please ensure that your product is shipped fully insured in the original packaging or equivalent. This warranty will not apply where the product is damaged due to improper packaging.
2. Include the following:
 - The RMA number supplied by Xantrex Technology Inc clearly marked on the outside of the box.
 - A return address where the unit can be shipped. Post office boxes are not acceptable.
 - A contact telephone number where you can be reached during work hours
 - A brief description of the problem
3. Ship the unit prepaid to the address provided by your Xantrex customer service representative.

WARRANTY

If you are returning a product from outside of the USA or Canada

In addition to the above, you MUST include return freight funds and are fully responsible for all documents, duties, tariffs, and deposits.

If you are returning a product to a Xantrex Authorized Service Center (ASC)

A Xantrex return material authorization (RMA) number is not required. However, you must contact the ASC prior to returning the product or presenting the unit to verify any return procedures that may apply to that particular facility.



Xantrex Technology Inc.
Toll free 1 800 670 0707
Direct 1 604 422 2777
Fax 1 604 420 2145
CustomerService@xantrex.com
www.xantrex.com

445-0206-01-01

Printed in the USA