



XPowEr Powerpack 200 Plus

Owner's Guide

About Xantrex

Xantrex Technology Inc. is a world-leading supplier of advanced power electronics and controls with products from 50 watt mobile units to one MW utility-scale systems for wind, solar, batteries, fuel cells, microturbines, and backup power applications in both grid-connected and stand-alone systems. Xantrex products include inverters, battery chargers, programmable power supplies, and variable speed drives that convert, supply, control, clean, and distribute electrical power.

Trademarks

XPower Powerpack 200 Plus is a trademark of Xantrex International. Xantrex is a registered trademark of Xantrex International.

Other trademarks, registered trademarks, and product names are the property of their respective owners and are used herein for identification purposes only.

Notice of Copyright

XPower Powerpack 200 Plus Owner's Guide © August 2006 Xantrex International. All rights reserved.

Exclusion for Documentation

UNLESS SPECIFICALLY AGREED TO IN WRITING, XANTREX TECHNOLOGY INC. ("XANTREX")

- (a) MAKES NO WARRANTY AS TO THE ACCURACY, SUFFICIENCY OR SUITABILITY OF ANY TECHNICAL OR OTHER INFORMATION PROVIDED IN ITS MANUALS OR OTHER DOCUMENTATION.
- (b) ASSUMES NO RESPONSIBILITY OR LIABILITY FOR LOSSES, DAMAGES, COSTS OR EXPENSES, WHETHER SPECIAL, DIRECT, INDIRECT, CONSEQUENTIAL OR INCIDENTAL, WHICH MIGHT ARISE OUT OF THE USE OF SUCH INFORMATION. THE USE OF ANY SUCH INFORMATION WILL BE ENTIRELY AT THE USER'S RISK; AND
- (c) REMINDS YOU THAT IF THIS MANUAL IS IN ANY LANGUAGE OTHER THAN ENGLISH, ALTHOUGH STEPS HAVE BEEN TAKEN TO MAINTAIN THE ACCURACY OF THE TRANSLATION, THE ACCURACY CANNOT BE GUARANTEED. APPROVED XANTREX CONTENT IS CONTAINED WITH THE ENGLISH LANGUAGE VERSION WHICH IS POSTED AT WWW.XANTREX.COM.

Date and Revision

August 2006 Revision C

Part Number

975-0189-01-01

Product Number

852-0200

Contact Information

Phone: 1 360-925-5059

Fax: 1 360-925-5143

Website: www.xantrex.com/support

About This Guide

Purpose

The purpose of this Owner's Guide is to provide explanations and procedures for installing, operating, maintaining, and troubleshooting the XPower Powerpack 200 Plus.

Organization

This guide is organized into five chapters and an appendix: Chapter 1, "Introduction", provides an overview of the main features of the XPower Powerpack 200 Plus.

Chapter 2, "Features", provides a detailed description of the features of the XPower Powerpack.

Chapter 3, "Operation", gives instructions for the main operational procedures of the XPower Powerpack, including operating AC and DC appliances, using the air compressor, and boosting an engine.

Chapter 4, "Maintenance", gives instructions for recharging the XPower Powerpack and changing the built-in light bulb.

Chapter 5, "Troubleshooting", provides a troubleshooting guide to the XPower Powerpack.

Appendix A, "Specifications", provides the electrical and physical specifications of the XPower Powerpack.

"Warranty and Return" at the end of this guide provides detailed warranty information and instructions for getting warranty service.

Conventions Used

The following conventions are used in this guide.



WARNING

Warnings identify conditions or practices that could result in personal injury or loss of life.



CAUTION

Cautions identify conditions or practices that could result in damage to the unit or to other equipment.

Important: These notes describe an important action item or an item that you must pay attention to.

Abbreviations and Acronyms

A	Ampere(s)
AC	Alternating Current
AGM	Absorbed Glass Mat
Ah	Amp-hours
ASC	Authorized Service Centre
DC	Direct Current
Hz	Hertz
mA	Milli-ampere
MHI	Metal halide arc
RMS	Root Mean Square
UPS	Uninterruptible Power Supply
V	Volt(s)
W	Watt(s)

Important Safety Instructions

The XPower Powerpack 200 Plus generates a type of AC power similar to a normal household wall outlet. Operating the XPower Powerpack 200 Plus incorrectly or misusing it may damage the equipment or create hazardous conditions for the user.

Important: Before using your XPower Powerpack 200 Plus, be sure to read and save these safety instructions.

Warnings and Cautions



WARNING: Shock hazard. Keep away from children.

The XPower Powerpack 200 Plus generates the same potentially lethal AC power as a normal household wall outlet. Do not insert foreign objects into the AC Power Outlet, the DC Power Outlet, or the ventilation holes. Do not expose this product to water, rain, snow, or spray.
Do not open the XPower Powerpack 200 Plus. There are no user-serviceable parts inside the unit.



CAUTION

Do not connect any AC appliance with the neutral conductor connected to ground to the XPower Powerpack 200 Plus.



CAUTION

Do not expose the XPower Powerpack 200 Plus to temperatures over 40°C (104°F).



WARNING: Explosion hazard

Do not use this product where there are flammable fumes or gases, such as in the bilge of a gasoline-powered boat, or near propane tanks. Do not use this product in an enclosure containing automotive-type lead-acid batteries. These batteries, unlike the sealed AGM battery in the XPower Powerpack 200 Plus, vent explosive hydrogen gas which can be ignited by sparks from electrical connections.

When working on electrical equipment, always ensure someone is nearby to help you in an emergency.



WARNING: Heated surface

Ensure at least 2" (5 cm) air space is maintained on all sides of the XPower Powerpack 200 Plus. During operation, keep away from materials that may be affected by high temperatures such as blankets, pillows and sleeping bags.



WARNING: Fire hazard

Never allow boosting cables' red and black clamps to touch each other or another common metal conductor. This could cause damage to the unit and/or create a sparking/explosion hazard. Always store boosting clamps in the appropriate holder on each side of the XPower Powerpack after use.



WARNING: Fire hazard

Boosting cable clamps must be connected positive to positive (red clamp to battery "+") and negative to negative (black clamp to battery "-"). A reverse polarity connection (positive to negative) may cause damage to the unit and/or create a sparking/explosion hazard.



WARNING: Limitations on use

The XPower Powerpack 200 Plus should not be used in connection with life support systems or other medical equipment or devices.



WARNING: Fire hazard

The boosting feature is designed for short term operation only—less than 4 seconds. Operating the boosting feature for more than 4 seconds may cause damage to the unit. Allow the XPower Powerpack 200 Plus to cool down for at least 3 minutes after each boost.



WARNING: Fire hazard

Do not leave the compressor unattended while operating. The compressor is designed for short term operation only. Operation of the compressor over an extended period of time will cause the compressor unit to overheat and may cause damage. Allow the compressor to cool down for 10 minutes after each 10 minutes of continuous operation.

Precautions When Working With Your Vehicle Battery



WARNING: Risk of Explosion, Fire or Burns

1. Follow all instructions published by the battery manufacturer and the manufacturer of the equipment in which the battery is installed.
2. Make sure the area around the battery is well-ventilated.
3. Never smoke or allow a spark or flame in vicinity of the engine or batteries.
4. Be careful not to drop a metal object on the battery or allow a metal tool to simultaneously touch the positive and negative cable ends or battery terminals. It might spark or short-circuit the battery or other electrical parts and cause an explosion.
5. Remove personal metal items such as rings, bracelets, necklaces, and watches when working with a lead-acid battery. A lead-acid battery produces a short-circuit current high enough to weld a ring or other similar objects to metal, causing a severe burn.
6. If you need to remove a battery, always remove the positive terminal from the battery first. Make sure all accessories are off so you don't cause an arc.
7. Someone should be within range of your voice, or close enough to come to your aid when you work near a lead-acid battery.
8. Have plenty of fresh water and soap nearby in case battery acid contacts skin, clothing, and/or eyes.
9. Wear complete eye protection and clothing protection. Avoid touching your eyes while working near batteries.

10. If battery acid contacts skin or clothing, wash immediately with soap and water. If acid enters your eyes, immediately flood them with running cold water for at least twenty minutes and get medical attention immediately.
11. Keep a supply of baking soda on hand in the area of the batteries. Baking soda neutralizes lead-acid battery electrolyte.

Precautions for Using Rechargeable Appliances



CAUTION

The output of the XPower Powerpack 200 Plus inverter is non-sinusoidal.

Most rechargeable battery-operated equipment use a separate charger or transformer that is plugged into an AC receptacle and produces a low voltage charging output.

Some chargers for rechargeable batteries can be damaged if connected to the XPower Powerpack 200 Plus.

Do not use the following with the XPower Powerpack 200 Plus:

- Small battery-operated appliances like flashlights, razors, and night lights that can be plugged directly into an AC receptacle to recharge.
- Some chargers for battery packs used in hand power tools. These affected chargers display a warning label stating that dangerous voltages are present at the battery terminals.

Note: If you are unsure about using your rechargeable appliance with the XPower Powerpack 200 Plus, contact the equipment manufacturer to determine the rechargeable appliance's compatibility with the modified sine wave (non-sinusoidal) AC waveform.

Contents

1 Introduction

About the XPower Powerpack	1
Comprehensive Protection	1
Automatic Overload	1
Overheating	1
Low Battery Protection	2

2 Features

Materials List	3
XPower Powerpack Features	4
Front Panel Detail	4
Left Side View	6
Accessories	7

3 Operation

Attention: Charge Before Use	9
Operating Conditions and Guidelines	9
Choosing a Location	10
Using XPower Powerpack for the First Time	11
Recharging with the AC Charger	11
Using the Built-in Light	12
Operating AC Appliances	12
Understanding AC Appliances	12
Run Time on Typical AC Appliances	12
High Surge Appliances	13
Trouble Appliances	13
Operating Several Appliances at Once	14
Operating an AC Appliance	14
Operating 12 V DC Appliances	16

Contents

Boosting a Vehicle's Engine	17
Using the Air Compressor	20
Over-temperature Safety Protection	20
Inflating Tires	21
Inflating Small Sports Equipment	22
Connecting to an External Battery	23
4 Maintenance	
Battery Maintenance	25
Recharging the XPower Powerpack Battery	26
Recharging with the AC Charger	26
Recharging with the DC Charging Cable	27
Recharging with a Generator's Regulated 12 V DC Outlet	29
Recharging from a Solar Panel	30
Recycling	31
Replacing the Built-in Light	31
5 Troubleshooting	
Common Problems	33
Buzz in Audio Equipment	33
Television Interference	33
Troubleshooting Reference	34
A Specifications	
Electrical Specifications	39
Physical Specifications	41
Warranty and Return	43

1

Introduction

About the XPower Powerpack

Easy-to-use and designed for years of reliable service, the XPower Powerpack can run many AC appliances and 12 V DC appliances whenever you need power for work or play, at home or on the road.

XPower Powerpack:

- Powers 115 V AC appliances
- Powers 12 V DC appliances
- Boosts vehicle engines
- Provides lighting for emergency use
- Inflates vehicle tires and small sports equipment

Comprehensive Protection

Automatic Overload

The XPower Powerpack has built-in protection against output overload. If you connect an appliance that draws more than 200 W to the AC Power Outlet on the XPower Powerpack, or one which draws excessive surge power, the power to the AC Power Outlet automatically shuts off.

Overheating

The XPower Powerpack is protected from overheating. If the inverter exceeds a safe temperature, power to the AC Power Outlet automatically shuts off.

Low Battery Protection

Low battery protection protects the internal battery from excessive discharge and possible damage. When the AC Power On/Off Switch is turned ON, an audible alarm alerts you when the internal battery is nearly discharged (11.0 V DC) and the unit turns OFF at 10.5 V DC.

2 Features

Chapter 2 describes the main features of the XPower Powerpack. We recommend that you familiarize yourself with these features before operating the unit.

Materials List

Your XPower Powerpack package includes these items:

- XPower Powerpack
- Owner's Guide
- AC Charger
- DC Charging Cable
- Nozzle and needle adaptors for the compressor

XPower Powerpack Features

Front Panel Detail

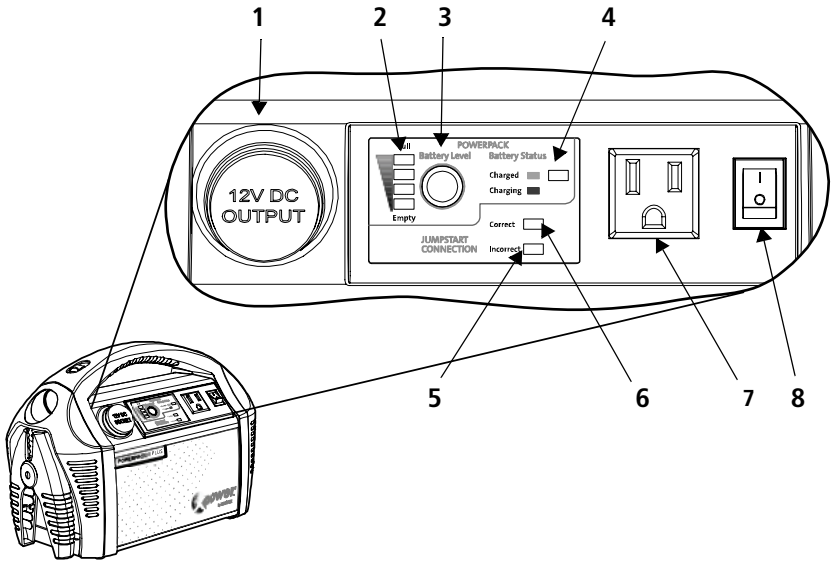

Feature	Description
1	<p>DC Power Outlet:</p> <ul style="list-style-type: none"> • Powers 12 V DC auto, RV or marine appliances • Recharges XPower Powerpack from a 12 V outlet in a vehicle using the DC Charging Cable.
2	<p>Battery Level LEDs illuminate to indicate the XPower Powerpack battery charge level. All LEDs (two green, one yellow and one red) are illuminated when the battery is fully charged (Full), only the red LED is illuminated when the battery is completely discharged (Empty).</p>
3	<p>Battery Level button triggers the Battery Level Full/Empty LED indicators. Press to view the battery charge status.</p>

Feature	Description
4	Battery Status LED illuminates when the XPower Powerpack is in Charging Mode (i.e., an AC Charger is connected to the XPower Powerpack's AC Charger Input Socket and plugged into the household 120 V AC outlet).
5	Red Boosting Connection LED illuminates and an alarm sounds when the boosting clamps are improperly connected to the vehicle battery.
6	Green Boosting Connection LED illuminates when the Boosting clamps are properly connected to the vehicle battery.
7	AC Power Outlet is a standard 3-prong outlet supplying 120 V AC power for running an AC appliance.
8	AC Power On/Off Switch illuminates when the switch is turned ON.
Not shown	Audible Alarm (inside the unit) sounds in the event of overheating or low XPower Powerpack battery condition.

Left Side View

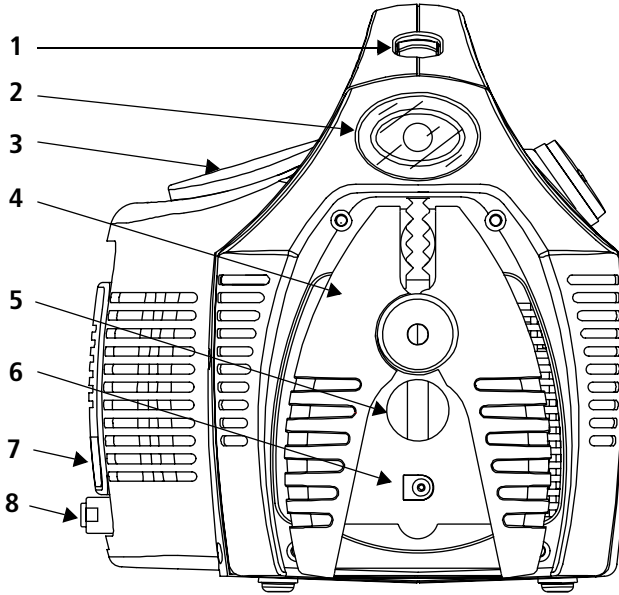

Feature	Description
1	Light On/Off Switch
2	Incandescent Light illuminates for about 15 hours when the battery is fully charged.
3	Pressure Gauge shows the PSI (lb/in ²).
4	Boosting Clamp
5	Boosting Power Switch
6	AC Charger Input Socket
7	On/Off Switch turns compressor unit on and off.
8	Valve connector with connector hose

Accessories

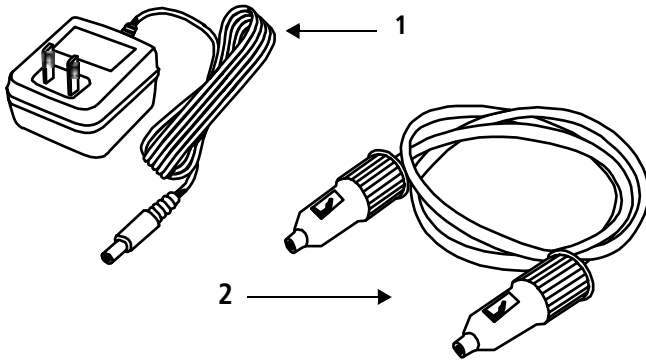

Accessory	Description
1	AC Charger lets you recharge the XPower Powerpack from a standard AC wall outlet and can only be used to recharge the internal battery of the XPower Powerpack. (Replacement part number 074-1003.)
2	DC Charging Cable lets you recharge the XPower Powerpack from a 12 V system in a car, SUV, RV or a boat.
Not shown	Nozzle packet containing nozzle adaptors and sports needle adaptor.

3 Operation

Chapter 3 explains how to operate the XPower Powerpack efficiently. This chapter covers:

- Recharging the XPower Powerpack for first-time use
- Using the built-in light
- Operating AC appliances and 12 V DC appliances
- Boosting a vehicle's engine
- Using the air compressor
- Connecting to an external battery for additional run time

Attention: Charge Before Use

Charge the XPower Powerpack for at least 48 hours immediately after purchase. Recharge after each use and once every three months. See “Recharging the XPower Powerpack Battery” on page 26.

Failure to follow these instructions will void the product warranty.

Operating Conditions and Guidelines



CAUTION

Read all operating instructions before operating the XPower Powerpack.



CAUTION

Do not use the XPower Powerpack to operate any AC appliances or 12 V DC appliances while recharging with the AC Charger.

The AC Charger may fail if AC appliances or 12 V DC appliances are operated while the AC Charger is connected.



CAUTION

The XPower Powerpack is not intended for use as a UPS (Uninterruptible Power Supply).

Choosing a Location



WARNING: Fire or explosion

The XPower Powerpack contains components that tend to produce arcs or sparks. To prevent fire or explosion, do not operate the XPower Powerpack in compartments containing batteries or flammable materials, or in locations that require ignition-protected equipment.

The XPower Powerpack should be operated only in a location that meets these requirements:

- | | |
|-------------------------------------|-------------------------------------------------------------------------------------------------------------------------------------------------------------------------|
| Dry | Do not allow water or other liquids to drop or splash on the XPower Powerpack. |
| Cool | Ambient air temperature should be between 0 and 40°C (32 and 104°F)—the cooler the better within this range. |
| Ventilated | Leave at least 2" (5 cm) clearance around the XPower Powerpack for air flow. Ensure that the ventilation openings are not obstructed. |
| Safe | Do not operate the unit in the same compartment as batteries or in any compartment capable of storing flammable liquids like gasoline. |
| Protected from battery gases | Do not operate the XPower Powerpack where it will be exposed to battery gases. These gases are very corrosive, and prolonged exposure will damage the XPower Powerpack. |

Using XPower Powerpack for the First Time

Important: Prior to operating your AC appliance or 12 V DC appliance, ensure that the battery of the XPower Powerpack is fully charged. If the battery has been fully discharged, recharging with the AC Charger may take up to 24 hours.

Recharging with the AC Charger

Note: The XPower Powerpack battery level LEDs are only accurate when the XPower Powerpack has been disconnected from all appliances and all charging sources for fifteen minutes.

Recharging with the AC Charger is a true “plug-in-and-forget” charging method. We recommend leaving the AC Charger connected when the XPower Powerpack is not in use.

To recharge with the AC Charger:

1. Disconnect any 12 V DC appliances and turn the light OFF.
2. Turn the AC Power On/Off Switch to OFF.
3. Plug the AC Charger into a standard AC wall outlet.
4. Insert the AC Charger cable end into the AC Charger Input Socket located under the red boosting clamp (see figure on page 6).

The Battery Status LED changes from red to green when charging is complete (about 24 hours if the battery is completely discharged).

Important: The 24-hour charging time for the XPower Powerpack assumes that there is 120 V AC at the AC wall outlet. If the voltage is less than 120 V AC, it may take more than 24 hours to fully recharge the XPower Powerpack. If, after 24 hours of charging, the Battery Status LED remains red, continue to charge the unit for another 12 hours. The unit will be ready for use even if the Battery Status LED remains red.

Important: If you keep the XPower Powerpack in storage, the battery will self-discharge over time. Remember to recharge the battery every three months to keep the XPower Powerpack operational.

Note: Once fully charged, the charging current automatically reduces to a maintenance charge mode, and the XPower Powerpack may be left permanently connected to the AC Charger.

Using the Built-in Light

The XPower Powerpack has a built-in incandescent light which will operate for about 15 hours before the unit needs to be recharged. The On/Off switch is located above the light.

Operating AC Appliances

Understanding AC Appliances

AC appliances are rated by how much electrical power (in watts) they consume. XPower Powerpack can power most appliances within its continuous power rating (160 W, 1 A).

Some appliances may be difficult or impossible to operate from the XPower Powerpack. They may have high surge requirements or should not be run from the XPower Powerpack. See “High Surge Appliances” on page 13 and “Trouble Appliances” on page 13.

Run Time on Typical AC Appliances

Note: The fewer watts an AC appliance uses, the longer the XPower Powerpack will operate before recharging is required.

Typical AC appliances that can be used on the XPower Powerpack are listed in Table 3-1.

Table 3-1 AC Appliances and Run Times

AC Appliance	Watts ^a	Hours ^b
Cordless telephone (stand by)	5	20
Clock radio	8	11
Portable stereo	10	9
Fluorescent work light	14	5
Fireplace fan	20	4
Laptop computer	25	3
Table lamp	40	1 hr. 30 min.
Color TV – 13"	60	1 hr. 30 min.

a. Represents actual power consumption as measured on sample appliances.

b. Operating times assume a fully charged 12 Ah battery and may vary based on model/brand of appliance.

High Surge Appliances

The wattage rating of AC appliances is the average power used by the appliance. Appliances such as televisions and appliances with motors consume much more power than their average rating when they are first switched on.

Although the XPower Powerpack can supply momentary surge power up to 320 W, some appliances may exceed the capabilities of the XPower Powerpack and trigger the safety overload shutdown circuit.

Trouble Appliances



CAUTION

The output of the XPower Powerpack's inverter is non-sinusoidal. Some equipment may be damaged by the XPower Powerpack's inverter modified sine wave output (non-sinusoidal).

Some appliances, including the types listed below, may be damaged if they are connected to the inverter:

- Electronics that modulate RF (radio frequency) signals on the AC line will not work and may be damaged.

- Speed controllers found in some fans, power tools, kitchen appliances, and other loads may be damaged.
- Some chargers for small rechargeable batteries can be damaged. See “Precautions for Using Rechargeable Appliances” on page viii for details.
- Metal halide arc (MHI) lights can be damaged.

Note: If you are unsure about powering any device with the inverter, contact the manufacturer of the device.

Operating Several Appliances at Once

You can run several AC appliances if the total rating of all the appliances (in watts) does not exceed 160 W. You can run appliances using an AC power bar.

Run time, however, will decrease accordingly with the number of appliances being operated and the AC power being consumed.

Operating an AC Appliance

Before operating your AC appliance, ensure that the battery of the XPower Powerpack is fully charged. See “Recharging with the AC Charger” on page 11 for details.

To operate an AC appliance:

1. Turn the AC Power On/Off Switch to the ON position.
The switch illuminates to indicate AC power is available at the AC Power Outlet.
2. Remove the protective cover on the AC power outlet.
3. Plug the AC appliance into the AC Power Outlet and turn the appliance on. XPower Powerpack will operate most devices rated up to 160 W.
4. Recharge the XPower Powerpack as soon as possible after each use.

When using the XPower Powerpack to operate an AC appliance and the low battery warning sounds, the warning gives you time to shut your AC appliance off before loss of AC power.

If you ignore the warning, the XPower Powerpack automatically turns off a few minutes later to prevent battery damage.

In the event of an overload, low battery voltage or overheating, the XPower Powerpack automatically shuts down.

Operating 12 V DC Appliances

The XPower Powerpack can operate 12 V DC auto, RV, marine, or other portable appliances that draw 12 A or less from a 12 V DC power outlet or from a vehicle's lighter socket.



CAUTION: Equipment damage

The DC Power Outlet does not automatically switch off when the internal battery is discharged. To protect the internal battery against damage resulting from total discharge, We recommend that the AC Power On/Off Switch is turned ON when using the XPower Powerpack to operate a 12 V DC appliance.

Having the AC Power On/Off Switch turned ON enables the alarm to warn you when the 12 V DC appliance has nearly depleted the internal battery.

Note: The fewer watts a 12 V DC appliance draws, the longer the XPower Powerpack will operate before recharging is required.

Typical 12 V DC appliances that can be used on the XPower Powerpack are listed in Table 3-2.

Table 3-2 12 V DC Appliances and Run Times

12 V DC Appliance	Watts ^a	Hours ^b
Cellular telephone ^c	6	15
Stereo/CD player	10	9
Portable Cooler	30	2

- a. Represents actual power consumption as measured on sample appliances.
- b. Operating times assume a fully charged 12 Ah battery and may vary based on model or brand of appliance.
- c. Represents talk time available from 5 recharge cycles.

To operate a 12 V DC appliance:

1. Open the protective cover on the DC Power Outlet of the XPower Powerpack.
2. Plug the 12 V DC appliance into the DC Power Outlet on the left side of the unit, and turn the 12 V DC appliance on (if required).

If the 12 V DC appliance draws more than 12 A (or has a short-circuit defect), the internal circuit breaker of the XPower Powerpack shuts off the power to the 12 V DC appliance. If this occurs, unplug the 12 V DC appliance, and the internal circuit breaker automatically resets after a few seconds.

3. Fully recharge the XPower Powerpack as soon as possible after each use.

As the DC Power Outlet is internally wired directly to the XPower Powerpack's battery, extended operation of a 12 V DC appliance may result in excessive battery discharge. See Caution for Equipment damage on page 16.

Boosting a Vehicle's Engine

You can use the XPower Powerpack to boost a vehicle or boat engine (all 4 cylinder and most 6 cylinder engines) that has a 12 V starting battery using the supplied boost cables.



WARNING: Fire hazard

Never allow boosting cables' red and black clamps to touch each other or another common metal conductor. This could cause damage to the unit and/or create a sparking/explosion hazard. Always switch OFF the Boosting Power Switch and store boosting clamps in the appropriate holder on each side of the XPower Powerpack after use.



WARNING: Fire hazard

Boosting cable clamps' connection to the vehicle's battery terminals must be positive to positive (red clamp to battery "+") and negative to negative (black clamp to battery "-"). A reverse polarity connection (positive to negative) may cause damage to the unit and/or create a sparking/explosion hazard.

Important: Closely follow these instructions for boosting your vehicle as they may be different from the instructions supplied with other boosting products or boosting cables.

To boost a vehicle or boat engine:

1. Turn off the vehicle or boat ignition and all accessories.
2. Engage the park or emergency brake and place the transmission in park for an automatic or neutral for a manual.
3. If boosting a boat engine, purge the engine compartment and bilge of all fumes before boosting.
4. Position the XPower Powerpack on a flat, stable surface near the battery and away from all moving parts of the engine.

Ensure that the Boosting Power Switch is OFF.

5. Connect the red positive (+) clamp of the cables to the positive (+) terminal of the engine battery.

The battery's positive terminal is usually larger in diameter than the negative terminal. In most vehicles, the battery's positive terminal has a red wire connected to it.

6. Connect the black negative (-) clamp of the cables to the engine block, cylinder head, or other stationary heavy metal part of the motor.

If the Red Boosting Connection LED illuminates and the XPower Powerpack's alarm sounds, then reverse polarity has been detected. Correct polarity must be established before proceeding. Disconnect the boosting clamps from the vehicle's battery and redo steps 5 and 6 in this procedure.

If no alarm sounds, and the Green Boosting Connection LED is illuminated, then proceed to the next step.

7. Switch ON the boosting power switch.
Before starting the engine, make sure the XPower Powerpack and the cables are clear of belts and fans.
 8. Crank the engine for 4 seconds or until it starts, whichever is first.
-



WARNING: Fire hazard

Do not crank the engine for more than 4 seconds. The boosting feature is designed for short term operation only. Operating the boosting feature for more than 4 seconds may cause damage to the unit. Allow the XPower Powerpack to cool down for at least 3 minutes after each boost.

9. Switch OFF the Boosting Power Switch.
 10. Remove the red positive (+) clamp and then the black negative (-) clamp from the vehicle.
 11. Store the boosting clamps in the appropriate holder on each side of the XPower Powerpack.
-

Important: Recharge the XPower Powerpack as soon as possible after each use. See “Recharging the XPower Powerpack Battery” on page 26.

Using the Air Compressor



WARNING: Fire hazard

The compressor is designed for short term operation only. Operating the compressor over an extended period of time will cause the compressor unit to overheat which could lead to fire. Allow the compressor to cool down for 10 minutes after each 10 minutes of continuous operation.



WARNING: Risk of personal injury or damage to equipment

Never leave the compressor unattended while in operation. Keep out of reach of children. The compressor is capable of inflating to 250 PSI. Do not exceed the recommended pressure of either the compressor or the object being inflated. If either recommended pressure is exceeded, an explosion may result.



WARNING: Risk of personal injury or damage to equipment

Never leave the compressor unattended once it has switched itself off due to overheating. It will turn on again and continue inflating when its internal temperature drops. Turn the compressor off at the power switch after each use or any time the compressor turns off automatically.

Over-temperature Safety Protection

It is recommended that you follow the warnings and turn the compressor off for 10 minutes after every 10 minutes of operation. However, the XPower Powerpack 200 Plus is equipped with an over-temperature safety protection feature that automatically turns the compressor off if it begins to overheat. Once the compressor cools down to its normal operating temperature it will automatically turn on again and continue inflating. You should turn the compressor off at the power switch if this safety feature engages, and allow the compressor to cool for 15 minutes before re-starting.

Inflating Tires

Table 3-3 Pressure Specifications for Common Items

Tires	PSI	Other Inflatables	PSI
520-13	26	Football	13
A-78-14	26	Basketball	9
E78-14	30	Volleyball	5
H-78-14	24	Lawn Tractor Tire	22
HR-78-15	28		
Bicycle Tires			
27 x 1 ¼	85		
20 x 1 ½	40		

Note: The information in the table is for reference only. For precise pressure specifications, refer to the information supplied with the item to be inflated.



CAUTION

If the pressure gauge on the compressor indicates more than twice the recommended pressure for the object you are inflating, and you have only started to inflate the object, the valve connector is incorrectly connected to the valve stem. This may damage the XPower Powerpack 200 Plus. Remove and reattach the valve connector to the valve stem.

To inflate your vehicle, motorcycle, or bicycle tires:

1. Place the valve connector securely on the tire valve stem, push it as far as possible to allow normal airflow, and close the thumb latch. If necessary, use a supplied nozzle adaptor.
2. Turn the compressor on, and inflate your tire to the recommended pressure. Use Table 3-3 as a guide only.

3. Turn the compressor off after appropriate pressure is reached.
4. Open the thumb latch and remove the valve connector from the valve stem.
5. Check air pressure with a pressure gauge.

Note: Leave the thumb latch in the open position for storing to relieve pressure on the internal mechanisms.

Inflating Small Sports Equipment

You can use the compressor to inflate small sports equipment such as soccer balls and footballs.



CAUTION

The XPower Powerpack 200 Plus cannot be used to inflate large capacity inflatables such as float tubes, large air mattresses, and inflatable boats. These types of products require extended inflating times which may damage the compressor.

To inflate small sports equipment:

1. Place the valve connector fully on or into the valve receptacle on the item. Go to Step 4.
OR
If necessary, use a supplied nozzle adaptor.
2. Choose the appropriate nozzle adaptor, insert the nozzle adaptor into the valve stem and close the thumb latch.
3. Insert nozzle adaptor into the valve receptacle of the item.
4. Turn the compressor on and inflate to appropriate pressure.



WARNING: Fire hazard

Allow the compressor to cool down for 10 minutes after each 10 minutes of continuous operation.

5. Turn the compressor off before removing nozzle adaptor from valve stem.
-

6. Remove nozzle adaptor from valve connector and store in storage compartment.
-

Note: Leave the thumb latch in the open position for storing to relieve pressure on the internal mechanism.

Connecting to an External Battery

You can extend battery operating times by connecting the XPower Powerpack to a larger external battery.

For example, an external 60 Ah battery gives approximately five times the operating time of the XPower Powerpack internal 12 Ah battery.



WARNING: Fire hazard

Never allow boosting cables' red and black clamps to touch each other or another common metal conductor. This could cause damage to the unit and/or create a sparking/explosion hazard.



WARNING: Fire hazard

Boosting cable clamps must be connected positive to positive (red clamp to battery "+") and negative to negative (black clamp to battery "-"). A reverse polarity connection (positive to negative) may cause damage to the unit and/or create a sparking/explosion hazard.



WARNING: Acid spills

Use a sealed, non-spillable battery for indoor use. Common auto and marine batteries are not suitable for indoor use unless their fumes are vented outdoors. Common auto and marine batteries contain acid, which is hazardous if spilled. Wear eye protection and protective clothing when connecting the XPower Powerpack to an external battery.

To connect the XPower Powerpack to an external battery using the boosting cables:

1. Ensure that the boosting power switch is OFF.
 2. Connect the red positive (+) clamp of the cables to the red positive (+) terminal of the external battery.
-

3. Connect the black negative (–) clamp of the cables to the black negative (–) terminal of the external battery.
If the Red Boosting Connection LED illuminates and the Powerbox’s alarm sounds, then reverse polarity has been detected. Correct polarity must be established before proceeding. Disconnect the Boosting clamps from the vehicle’s battery and redo steps 2 and 3 in this procedure.
If no alarm sounds, and the Green Boosting Connection LED is illuminated, then proceed to the next step.
4. Switch ON the Boosting Power Switch.

To disconnect the cables from an external battery and from the XPower Powerpack:

1. Ensure that the Boosting Power Switch is OFF.
2. Remove the red positive (+) clamp, and then remove the black negative (–) clamp from the external battery terminals.
3. Store the boosting clamps in the appropriate holder on each side of the XPower Powerpack.
4. Recharge the XPower Powerpack as soon as possible after use.



CAUTION

Do not recharge the XPower Powerpack when an external battery is connected. The AC charger may be damaged.

4 Maintenance

Chapter 4 provides information on maintaining your internal battery, recharging options for the internal battery, and replacing user-replaceable parts.

Routine maintenance is required to keep your XPower Powerpack 200 Plus operating properly. Occasionally clean the exterior of the unit with a damp cloth to remove the accumulated dust and dirt.



WARNING: Shock hazard

Disconnect all sources of AC power and DC power before performing any type of maintenance.

Battery Maintenance

All rechargeable batteries gradually discharge when left standing, and you need to recharge them periodically to maintain maximum battery capacity. The AC Charger supplied with the XPower Powerpack is designed to regulate the charging process, ensuring that the battery is always fully charged but never overcharged. To ensure safe recharging and maximum battery life, recharge the XPower Powerpack only with the supplied charger or approved battery chargers.



CAUTION

Due to inherent self-discharge, lead acid batteries must be charged at least every 3 months, especially in a warm environment. Leaving a battery in a discharged state, or not recharging every 3 months, may result in permanent battery damage and poor boosting performance.



CAUTION

Do not attempt to recharge the XPower Powerpack battery if it is frozen. Gradually warm the frozen battery to 0°C (32°F) before recharging.

Recharging the XPower Powerpack Battery

To check the XPower Powerpack's charge level, press the Battery Level button.

Note: The XPower Powerpack Battery Level LEDs are only accurate when the XPower Powerpack has been disconnected from all appliances and all charging sources for 15 minutes.

You can recharge the battery using:

- the fully automatic “plug-in-and-forget” AC Charger.
- the DC Charging Cable to recharge from your vehicle as you drive.
- a generator equipped with a regulated 12 V battery charging outlet.
- a solar panel.

Recharging with the AC Charger

Recharging with the AC Charger is a true “plug-in-and-forget” charging method.



CAUTION

Do not operate AC or DC appliances while the XPower Powerpack is being recharged with the AC Charger.

The AC Charger may be permanently damaged if AC appliances or 12 V DC appliances are operated while the AC Charger is connected.

To recharge with the AC Charger:

1. Disconnect any 12 V DC appliance and turn the light switch to OFF.
 2. Turn the AC Power On/Off Switch to OFF.
 3. Plug the AC Charger into a standard AC wall outlet.
 4. Insert the AC Charger cable end into the AC Charger Input Socket located under the red boosting clamp.
-

5. While the XPower Powerpack is recharging, the Battery Status LED is red. If the XPower Powerpack is completely discharged, a typical recharge may take up to 24 hours. When fully charged, the Battery Status LED changes to green and the XPower Powerpack is ready to use.

Important: The 24-hour charging time for the XPower Powerpack assumes that there is 120 V at the AC wall outlet. If the voltage is less than 120 V AC, it may take more than 24 hours to fully recharge the XPower Powerpack. If, after 24 hours of charging, the Battery Status LED is still red, continue to charge the unit for another 12 hours. The XPower Powerpack will be ready for use even if the Battery Status LED remains red.

Once the XPower Powerpack is fully charged, the charging voltage and current automatically reduces to a maintenance level and the XPower Powerpack may be left permanently connected to the AC Charger. If your utility power is interrupted, the charging process automatically restarts when power returns.

Recharging with the DC Charging Cable

Using the DC Charging Cable, the XPower Powerpack can be recharged while you drive your vehicle.

Important: Although the charge regulation circuitry in the XPower Powerpack does not operate with this charging method, most vehicle voltage regulators will ensure that the XPower Powerpack is not overcharged.



WARNING: Fire and explosion hazard

Do not use this recharging method if your vehicle has abnormally high voltage electrical systems that operate above 15 V DC. This may lead to accumulations of hydrogen, causing exposure to fire and explosion hazard.



CAUTION

Do not operate AC or DC appliances while the XPower Powerpack is being recharged with the DC Charging Cable from your vehicle.

To recharge the XPower Powerpack while you drive using the DC Charging Cable:

1. While the vehicle engine is running, plug one end of the DC Charging Cable into the DC Power Outlet of the XPower Powerpack.
2. Plug the opposite end of the DC Charging Cable into the vehicle's lighter socket or 12 V accessory outlet.
3. Once the XPower Powerpack is fully charged or if your vehicle's engine is not running, disconnect the DC Charging Cable from both sockets.

Most of the XPower Powerpack's capacity will be restored in 2 ½ hours while the vehicle engine is running.

Note: The Battery Status LED will not illuminate when the XPower Powerpack is recharged through the DC Charging Cable.

Note: The Battery Level LEDs are only accurate when the XPower Powerpack has been disconnected from all appliances and all charging sources for 15 minutes.

Important: Do not leave the XPower Powerpack permanently connected to the vehicle's lighter socket or 12 V accessory outlet.

Recharging with a Generator's Regulated 12 V DC Outlet



WARNING: Fire and explosion hazard

The generator output must be intended for battery charging and have an output of 15 V or less. An unregulated output or one that exceeds 15 V DC can damage the battery.

This may lead to accumulations of hydrogen, causing exposure to fire and explosion hazard.

Refer to the Owner's Guide accompanying your generator for detailed instructions on connecting the generator to a unit like the XPower Powerpack.

You can recharge the XPower Powerpack using a generator in several ways:

- Using the AC Charger to recharge the XPower Powerpack from a generator is possible, but would require extended generator running time.
- Using a generator which has an auxiliary regulated 12 V DC output designed for charging 12 V DC batteries. Most generators are equipped with them. Use this power source for faster charging.
- Using a generator with a regulated 12 V DC lighter socket. Follow the connection instructions in "Recharging with the DC Charging Cable" on page 27.

Most of the XPower Powerpack's battery capacity will be recharged in a few hours.

Note: The Battery Level LEDs are only accurate when the XPower Powerpack has been disconnected from all appliances and all charging sources for 15 minutes.

Recharging from a Solar Panel

Small, unregulated 12 V solar panels rated to produce a maximum of 2.5 A (or 30 W) can be used to charge the XPower Powerpack through the AC Charger Input Socket.

You will need to purchase a standard 5.5 mm OD \times 2.5 mm ID (0.217 \times 0.10") coaxial DC (barrel type centre positive) connector to mate with the AC Charger Input Socket.

To locate this part, search on the Internet for 5.5 mm OD \times 2.5 mm ID plug for AC adaptor barrel-type coaxial plug for use with Universal AC Adaptors, or contact a consumer electronics parts store with this description.

To wire the coaxial DC connector:

1. Connect the solar panel's red positive (+) wire to the coaxial plug's inner or centre contact.
2. Connect the solar panel's black negative (-) wire to the plug's outer contact. See Figure 4-1.

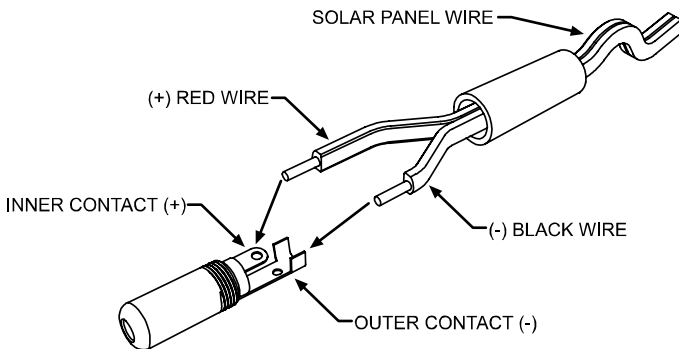

Figure 4-1 Typical DC Coaxial Connector Connection

Once the connector is inserted into the AC Charger Input Socket and the solar panel is placed in the sun, the XPower Powerpack charges automatically just as with the AC Charger. See “Recharging with the AC Charger” on page 26.

It takes about six hours in direct sunlight to recharge the XPower Powerpack from a 2.5 A solar panel.

Recycling

The XPower Powerpack is designed to provide years of service. However, when the internal battery reaches the end of its service life, the XPower Powerpack itself is no longer of use. The internal battery is not designed to be user replaceable.

Because the internal battery contains lead, which can be hazardous if exposed to the environment, the XPower Powerpack should be recycled or safely disposed of at your local recycling depot.

Do not dispose of the XPower Powerpack with common household waste. Please ask your local authorities about recycling services that are available in your area.

Replacing the Built-in Light

To replace the light bulb:

1. Turn the light switch off.
2. Pop out the plastic lens cover.
3. Gently grasp the bulb and twist clockwise to unscrew the bulb.
4. Insert a replacement bulb of the same type and rating into the light reflector assembly.
5. Gently grasp the bulb and twist counter-clockwise to screw the bulb in.
6. Snap in the lens cover.

5 Troubleshooting

Troubleshooting will help you identify the common problems than can occur with the XPower Powerpack 200 Plus.

Read this chapter before calling Customer Service.

If you cannot solve the problem with the XPower Powerpack, record the information asked for on “Information About Your System” on page 46 and then contact your dealer.

Common Problems

Buzz in Audio Equipment

Some inexpensive stereo systems have inadequate internal power-supply filtering and may buzz slightly when powered by the XPower Powerpack. The best solution to eliminate the buzzing is to use an audio system with a good quality filter.

Television Interference

The XPower Powerpack is shielded to minimize interference with TV signals. If TV signals are weak, you may see interference in the form of lines scrolling across the TV screen. Try one of the following suggestions to minimize or eliminate the interference:

- Increase the distance between the XPower Powerpack and the TV, antenna, and cables using a good quality extension cord (do not use a surge protector/power bar).
- Adjust the orientation of the XPower Powerpack, television, antenna, and cables.
- Maximize TV signal strength by using a better antenna. Use a shielded antenna cable where possible.
- Try a different TV. Different models vary considerably in their susceptibility to interference.

Troubleshooting Reference



WARNING: Electric shock hazard

Do not remove the cover of the XPower Powerpack or disassemble the XPower Powerpack. The XPower Powerpack does not contain any internal user-serviceable parts and attempting to service the unit yourself could result in electrical shock or burn and will void your warranty.

Table 5-1 Troubleshooting reference

Problem	Possible Cause	Solution
AC appliance will not operate; audible alarm is not sounding.	<p>AC appliance rated more than 160 W, the safety overload has tripped.</p> <p>AC appliance is rated less than 160 W, high starting surge has tripped the safety overload.</p>	<p>Use an AC appliance with a power rating less than 160 W.</p> <p>AC appliance may exceed the XPower Powerpack's surge capability. Use an AC appliance with a starting surge within the XPower Powerpack surge rating.</p>
Overload shutdown	Appliance power requirements exceed the capability of the XPower Powerpack.	Unplug the appliance and confirm that the appliance's power requirement is 160 W or less before attempting to restart the appliance.
Alarm sounds	<p>XPower Powerpack battery is nearly discharged (11.0 V).</p> <p>If you ignore this warning, the XPower Powerpack automatically switches off when the battery reaches 10.5 V.</p>	Turn OFF the AC Power On/Off Switch and recharge the XPower Powerpack.

Table 5-1 Troubleshooting reference

Problem	Possible Cause	Solution
<p>AC appliance will not operate; audible alarm is sounding.</p>	<p>Battery has discharged to 10.5 V.</p> <p>XPower Powerpack has overheated due to poor ventilation or excessively warm environmental conditions.</p>	<p>Turn OFF the AC Power On/Off Switch and recharge the XPower Powerpack.</p> <p>Turn the AC Power On/Off Switch OFF and allow the XPower Powerpack to cool for 15 minutes or more. Clear blocked opening or remove objects covering the unit, then restart the XPower Powerpack and move it to a cooler environment.</p>
<p>Run time is less than expected.</p>	<p>XPower Powerpack battery is not fully charged.</p> <p>AC appliance power consumption is higher than expected.</p> <p>Environmental temperature is less than 0°C (32°F) or more than 40°C (104°F)</p>	<p>Recharge using the AC Charger, until Battery Status LED is green.</p> <p>Check AC appliance power or wattage rating (or current draw for 12 V DC appliances) and compare with Table 3-1 on page 13 and Table 3-2 on page 16.</p> <p>Operate within correct temperature range.</p>

Table 5-1 Troubleshooting reference

Problem	Possible Cause	Solution
<p>Measured AC output voltage is too low.</p>	<p>Use of an average-reading, AC voltmeter to read output voltage.</p> <p>XPower Powerpack battery is almost fully discharged.</p>	<p>The modified sinewave (MSW) output of the XPower Powerpack requires a true RMS reading meter, such as the Fluke 87 series, for accurate measurement.</p> <p>Press Battery Level button to verify battery status and recharge the XPower Powerpack as necessary. Battery Level LEDs are only accurate when the PowerBox has been disconnected from all appliances and all charging sources for fifteen minutes.</p>
<p>The light does not turn on.</p>	<p>Light bulb has burnt out.</p>	<p>Remove lens cover and replace bulb with one of the same type and rating.</p>
<p>Battery Status LED is OFF when AC Charger is connected</p>	<p>No AC power at the AC wall outlet.</p> <p>AC Charger is faulty.</p>	<p>Ensure power is available at the AC wall outlet.</p> <p>Replace the AC Charger.</p>
<p>Battery Status LED is red and Battery Level LEDs show the battery is full when the Battery Level button is triggered.</p>	<p>Battery Level lights are only accurate when the XPower Powerpack has been disconnected from all appliances and all charging sources for 15 minutes.</p>	<p>Unplug the charging sources and any appliances and let the XPower Powerpack rest for 15 minutes to obtain an accurate reading.</p>

Table 5-1 Troubleshooting reference

Problem	Possible Cause	Solution
<p>Battery Status LED is red and has not changed to green after 24 hours of charging.</p>	<p>The voltage at the AC wall outlet is less than 120 V AC.</p>	<p>Use AC wall outlet that supplies 120 V AC.</p> <p>Continue to charge the unit for another 12 hours; the unit will be ready to use even if the Battery Status light remains red.</p>
<p>The engine being boosted will not start.</p>	<p>XPower Powerpack battery is not fully charged.</p> <p>The engine condition is poor.</p> <p>The engine start capacity exceeds the XPower Powerpack boosting capability.</p>	<p>Recharge the XPower Powerpack battery.</p> <p>Have the engine serviced.</p> <p>Use a higher power XPower Powerpack.</p>
<p>The battery clamps of the boosting cables measure zero volts.</p>	<p>Boosting power switch is OFF.</p> <p>XPower Powerpack battery is discharged.</p>	<p>Turn boosting power switch ON.</p> <p>Recharge XPower Powerpack.</p>
<p>The compressor runs, but won't inflate.</p>	<p>The valve connector may not be securely placed on the valve stem.</p> <p>The item being inflated may have a leak.</p>	<p>Make sure the valve connector is securely placed on the valve stem before closing the thumb latch.</p> <p>Make sure the item being inflated doesn't have a leak. Check the compressor hose for any breaks or leaks.</p>

Table 5-1 Troubleshooting reference

Problem	Possible Cause	Solution
The compressor runs slowly.	The compressor may have overheated from excessive use.	Turn off the compressor and let it cool down.
	Battery voltage is too low.	Check the condition of the internal battery. The battery may need to be recharged or replaced.

A Specifications

Electrical Specifications

12 V DC Section	
Internal battery type	Sealed/non-spillable, AGM (Absorbed Glass Mat) lead-acid
Internal battery voltage (nominal)	12 V DC
Internal battery capacity (minimum)	12 Ah
Internal battery CCA rating	120 CCA
Internal battery CA rating	180 CA
DC Power Outlet (maximum continuous load)	12 A with automatic reset
Built-in incandescent light (replaceable)	5 W bulb

Electrical Specifications

AC Power Section	
Output power <ul style="list-style-type: none">• Continuous output power• Five minute AC output power• AC output surge capacity	160 W 200 W 320 W
Output voltage	115 ± 10 V AC RMS
Output frequency	60 Hz ± 1 Hz
Output wave form	modified sinewave
No load current draw	<0.20 A DC
Input voltage range	10.5 to 15.5 V DC
Low battery alarm	11.0 V DC
Low battery shutdown	10.5 V DC
High battery voltage shutdown	Yes, automatic reset
Over temperature shutdown	Yes, automatic reset
Overload shutdown	Yes, automatic reset
AC output short circuit protection	Yes, automatic reset
Fuse (internal)	25 A
Operating temperature range	0–40°C (32–104°F)
Storage temperature range	0–30°C (32–86°F)

Internal Battery Charging Controller System	
AC Charger bulk charging current	500 mA
Peak charging voltage (nominal)	14.2 V
Charge restart voltage (nominal)	12.9 V
Float charge after full charge is completed (nominal)	1 mA
AC Charger input socket maximum current	2.5 A

Air Compressor	
Pressure	250 PSI (lb/in ²)

Accessories	
DC charge cable	39" (1 m) 18 AWG with male to male lighter plugs. Part # 449-0187-01-01
AC Charger	Part # 074-1003

Physical Specifications

Physical specifications	XPower Powerpack
Depth	6 1/8" (15.5 cm)
Width	12 13/32" (31.5 cm)
Height	8 3/4" (22.1 cm)
Weight	11 lb 13 oz (5.4 kg)

Physical specifications	Internal SW12120 battery
Length	6" (15.1 cm)
Width	2 1/2" (6.5 cm)
Height with terminals	5" (12.5 cm)
Terminal type	M5 bolt type

Important: All specifications are subject to change without notice.

Warranty and Return

Warranty

What does this warranty cover? This Limited Warranty is provided by Xantrex Technology Inc. ("Xantrex") and covers defects in workmanship and materials in your XPower Powerpack 200 Plus. This warranty period lasts for 6 months from the date of purchase at the point of sale to you, the original end user customer. You will be required to demonstrate proof of purchase to make warranty claims.

What will Xantrex do? Xantrex will, at its option, repair or replace the defective product free of charge, provided that you notify Xantrex of the product defect within the Warranty Period, and provided that Xantrex through inspection establishes the existence of such a defect and that it is covered by this Limited Warranty.

Xantrex will, at its option, use new and/or reconditioned parts in performing warranty repair and building replacement products. Xantrex reserves the right to use parts or products of original or improved design in the repair or replacement. If Xantrex repairs or replaces a product, its warranty continues for the remaining portion of the original Warranty Period or 90 days from the date of the return shipment to the customer, whichever is greater. All replaced products and all parts removed from repaired products become the property of Xantrex.

Xantrex covers both parts and labor necessary to repair the product, and return shipment to the customer via a Xantrex-selected non-expedited surface freight within the contiguous United States and Canada. Alaska and Hawaii are excluded. Contact Xantrex Customer Service for details on freight policy for return shipments outside of the contiguous United States and Canada.

How do you get service? If your product requires troubleshooting or warranty service, contact your dealer.

If you are unable to contact your dealer, or the dealer is unable to provide service, contact Xantrex directly at:

Phone: 1 360-925-5059

Fax: 1 360-925-5143

Website: www.xantrex.com/support

Direct returns may be performed according to the Xantrex Return Material Authorization Policy described in your product manual. For some products, Xantrex maintains a network of regional Authorized Service Centers. Call Xantrex or check our website to see if your product can be repaired at one of these facilities.

What proof of purchase is required? In any warranty claim, dated proof of purchase must accompany the product and the product must not have been disassembled or modified without prior written authorization by Xantrex.

Proof of purchase may be in any one of the following forms:

- The dated purchase receipt from the original purchase of the product at point of sale to the end user, or
- The dated dealer invoice or purchase receipt showing original equipment manufacturer (OEM) status, or
- The dated invoice or purchase receipt showing the product exchanged under warranty

Warranty and Return

What does this warranty not cover? This Limited Warranty does not cover normal wear and tear of the product or costs related to the removal, installation, or troubleshooting of the customer's electrical systems. This warranty does not apply to and Xantrex will not be responsible for any defect in or damage to:

- a) the product if it has been misused, neglected, improperly installed, physically damaged or altered, either internally or externally, or damaged from improper use or use in an unsuitable environment;
- b) the product if it has been subjected to fire, water, generalized corrosion, biological infestations, or input voltage that creates operating conditions beyond the maximum or minimum limits listed in the Xantrex product specifications including high input voltage from generators and lightning strikes;
- c) the product if repairs have been done to it other than by Xantrex or its authorized service centers (hereafter "ASCs");
- d) the product if it is used as a component part of a product expressly warranted by another manufacturer;
- e) the product if its original identification (trade-mark, serial number) markings have been defaced, altered, or removed.

Disclaimer

Product

THIS LIMITED WARRANTY IS THE SOLE AND EXCLUSIVE WARRANTY PROVIDED BY XANTREX IN CONNECTION WITH YOUR XANTREX PRODUCT AND IS, WHERE PERMITTED BY LAW, IN LIEU OF ALL OTHER WARRANTIES, CONDITIONS, GUARANTEES, REPRESENTATIONS, OBLIGATIONS AND LIABILITIES, EXPRESS OR IMPLIED, STATUTORY OR OTHERWISE IN CONNECTION WITH THE PRODUCT, HOWEVER ARISING (WHETHER BY CONTRACT, TORT, NEGLIGENCE, PRINCIPLES OF MANUFACTURER'S LIABILITY, OPERATION OF LAW, CONDUCT, STATEMENT OR OTHERWISE), INCLUDING WITHOUT RESTRICTION ANY IMPLIED WARRANTY OR CONDITION OF QUALITY, MERCHANTABILITY OR FITNESS FOR A PARTICULAR PURPOSE. ANY IMPLIED WARRANTY OF MERCHANTABILITY OR FITNESS FOR A PARTICULAR PURPOSE TO THE EXTENT REQUIRED UNDER APPLICABLE LAW TO APPLY TO THE PRODUCT SHALL BE LIMITED IN DURATION TO THE PERIOD STIPULATED UNDER THIS LIMITED WARRANTY.

IN NO EVENT WILL XANTREX BE LIABLE FOR ANY SPECIAL, INDIRECT, INCIDENTAL OR CONSEQUENTIAL DAMAGES, LOSSES, COSTS OR EXPENSES HOWEVER ARISING WHETHER IN CONTRACT OR TORT INCLUDING WITHOUT RESTRICTION ANY ECONOMIC LOSSES OF ANY KIND, ANY LOSS OR DAMAGE TO PROPERTY, ANY PERSONAL INJURY, ANY DAMAGE OR INJURY ARISING FROM OR AS A RESULT OF MISUSE OR ABUSE, OR THE INCORRECT INSTALLATION, INTEGRATION OR OPERATION OF THE PRODUCT.

Exclusions

If this product is a consumer product, federal law does not allow an exclusion of implied warranties. To the extent you are entitled to implied warranties under federal law, to the extent permitted by applicable law they are limited to the duration of this Limited Warranty. Some states and provinces do not allow limitations or exclusions on implied

warranties or on the duration of an implied warranty or on the limitation or exclusion of incidental or consequential damages, so the above limitation(s) or exclusion(s) may not apply to you. This Limited Warranty gives you specific legal rights. You may have other rights which may vary from state to state or province to province.

Return Material Authorization Policy

Before returning a product directly to Xantrex you must obtain a Return Material Authorization (RMA) number and the correct factory "Ship To" address. Products must also be shipped prepaid. Product shipments will be refused and returned at your expense if they are unauthorized, returned without an RMA number clearly marked on the outside of the shipping box, if they are shipped collect, or if they are shipped to the wrong location.

When you contact Xantrex to obtain service, please have your instruction manual ready for reference and be prepared to supply:

- The serial number of your product
- Information about the installation and use of the unit
- Information about the failure and/or reason for the return
- A copy of your dated proof of purchase

Record these details in "Information About Your System" on page 46.

Return Procedure

1. Package the unit safely, preferably using the original box and packing materials. Please ensure that your product is shipped fully insured in the original packaging or equivalent. This warranty will not apply where the product is damaged due to improper packaging.
2. Include the following:
 - The RMA number supplied by Xantrex Technology Inc. clearly marked on the outside of the box.
 - A return address where the unit can be shipped. Post office boxes are not acceptable.
 - A contact telephone number where you can be reached during work hours.
 - A brief description of the problem.
3. Ship the unit prepaid to the address provided by your Xantrex customer service representative.

If you are returning a product from outside of the USA or Canada In addition to the above, you **MUST** include return freight funds and are fully responsible for all documents, duties, tariffs, and deposits.

If you are returning a product to a Xantrex Authorized Service Center (ASC) A Xantrex return material authorization (RMA) number is not required. However, you must contact the ASC prior to returning the product or presenting the unit to verify any return procedures that may apply to that particular facility and that the ASC repairs this particular Xantrex product.

Out of Warranty Service

If the warranty period for your XPower Powerpack 200 Plus has expired, if the unit was damaged by misuse or incorrect installation, if other conditions of the warranty have not been met, or if no dated proof of purchase is available, your unit may be serviced or replaced for a flat fee.

To return your XPower Powerpack 200 Plus for out of warranty service, contact Xantrex Customer Service for a Return Material Authorization (RMA) number and follow the other steps outlined in “Return Procedure” on page 45.

Payment options such as credit card or money order will be explained by the Customer Service Representative. In cases where the minimum flat fee does not apply, as with incomplete units or units with excessive damage, an additional fee will be charged. If applicable, you will be contacted by Customer Service once your unit has been received.

Information About Your System

As soon as you open your XPower Powerpack 200 Plus package, record the following information and be sure to keep your proof of purchase.

- Product Number (FGA) 852-0200
- Serial Number (on DC end) _____
- Purchased From _____
- Purchase Date _____

If you need to contact Customer Service, please record the following details before calling. This information will help our representatives give you better service.

- Warning, Error or Panel
Fault Message _____
 - Appliances operating when
problem occurred _____
 - Description of problem _____
- _____
- _____