

Robin Power Equipment®

PARTS MANUAL

Model

R650

Generator

PUB-GP0456

Rev. 8/98

Robin
SUBARU

HOW TO USE THIS PARTS CATALOG

THE MODEL, SPECIFICATION, SPECIFICATION NUMBER AND SERIAL NUMBER OF THE GENERATOR MUST BE GIVEN WHEN ORDERING PARTS

Specification and specification number are shown on the nameplate located on the rear cover.

WRITE DOWN THE MODEL, SPECIFICATION, SPECIFICATION NUMBER AND SERIAL NUMBER IN THE SPACES PROVIDED BELOW SO THAT IT WILL BE AVAILABLE TO YOU WHEN ORDERING PARTS.

■ FREQUENCY		Hz /		Hz				
■ AC VOLTAGE				V				
■ AC OUTPUT	MAX		W /		W			
	RATED		W /		W			
■ DC OUTPUT			V -		A			
● CHECK OIL LEVEL BEFORE USING AND REFILL OIL UP TO THE MAXIMUM LEVEL								
● CHANGE OIL						AFTER 20 HOURS.	EVERY 100 HOURS.	
FUJI HEAVY INDUSTRIES LTD. TOKYO JAPAN								
SPEC. NO.								

The serial number is stamped on the crankcase at the opposite side of the carburetor.

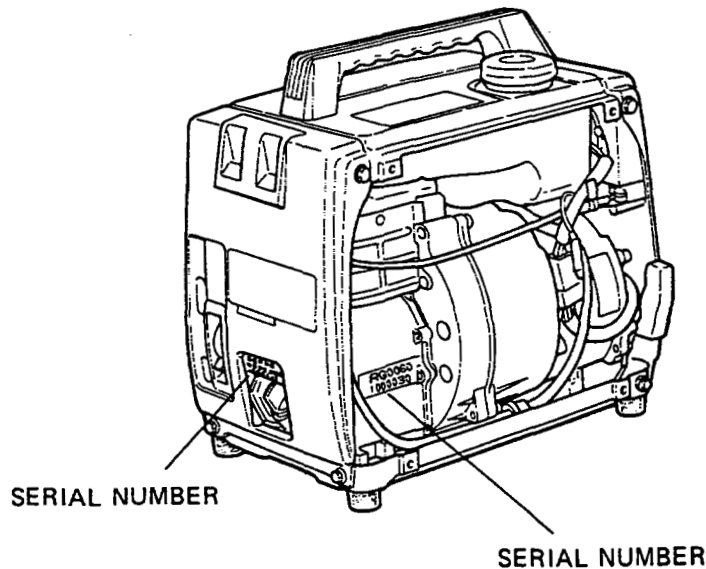

HOW TO READ THIS PARTS CATALOG

1. Reference numbers with an asterisk

Reference numbers marked with an asterisk indicate that the particular part is available only as a complete set or assembly.

Example:

If the reference number is marked with an asterisk and the description of the part states that certain items are included, this means that those included items cannot be ordered separately and must be purchased as a complete assembly.

2. Description of interchangeability and execution columns

Example: Interchangeability column

- o Items interchangeable between the new and old parts
- x Items not interchangeable between the new and old parts
- y Items conditionally interchangeable between the new and old parts which are subject to the description in the execution column.

Example: Execution column

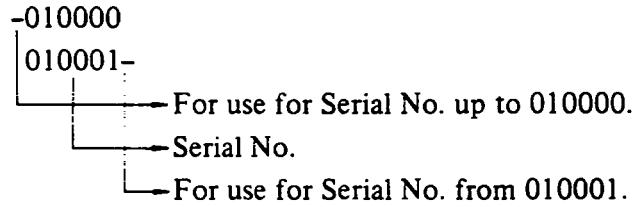

Example:

Part Number	Interchangeable	Execution	Explanation
Part B Part A	o	020000-	This indicates that Part A changed to Part B for generators with serial numbers from 20000, and that they are interchangeable.
Part C Part B Part A	o x	020000- 015000-	This indicates that Part A changed to Part B for generators with serial numbers from 15000, and that they are not interchangeable. Also, Part B changed to Part C for generators with serial numbers from 20000 and that they are interchangeable.
Part A		020000-	This indicates that Part A is a new part for generators with serial numbers from 20000.
Part B		-030000	This indicates that Part B is no longer used for generators with serial numbers from 30001.
Part B Part A	y	020000-	This indicates that Part A changed to Part B for generators with serial numbers from 20000, and that they are conditionally interchangeable (see NOTE described at the end of the section).

3. The contents of this parts catalog are subject to revision without notice.

TO INSURE PROMPT AND ACCURATE SERVICE, ALSO THE FOLLOWING INFORMATION MUST BE GIVEN.

1. State exactly the quantity of each part and its part number.
2. Clearly state whether parts are to be shipped by express, freight or parcel post.
3. State the exact mailing address.

CONTENTS

BODY and GENERATOR PARTS

Fig. 1	FUEL TANK	1
Fig. 2-1	CONTROL PANEL	2
Fig. 2-2	CONTROL PANEL (SPECIAL RECEPTACLE)	4
Fig. 3-1	GENERATOR (For 50/60 Hz)	8
Fig. 3-2	GENERATOR (For 60 Hz)	9
Fig. 4	COVER	10

ENGINE PARTS

Fig. 5-1	CRANKCASE	12
Fig. 5-2	CRANKCASE (with OIL SENSOR)	13
Fig. 6	CRANKSHAFT, PISTON and CAMSHAFT	15
Fig. 7-1	GOVERNOR (For 50/60 Hz)	16
Fig. 7-2	GOVERNOR (For 60 Hz)	17
Fig. 8	MUFFLER and FRONT HOUSING	18
Fig. 9	CARBURETOR and AIR CLEANER	19
Fig. 10	RECOIL STARTER	20

Fig. 1 FUEL TANK

BODY and GENERATOR PARTS

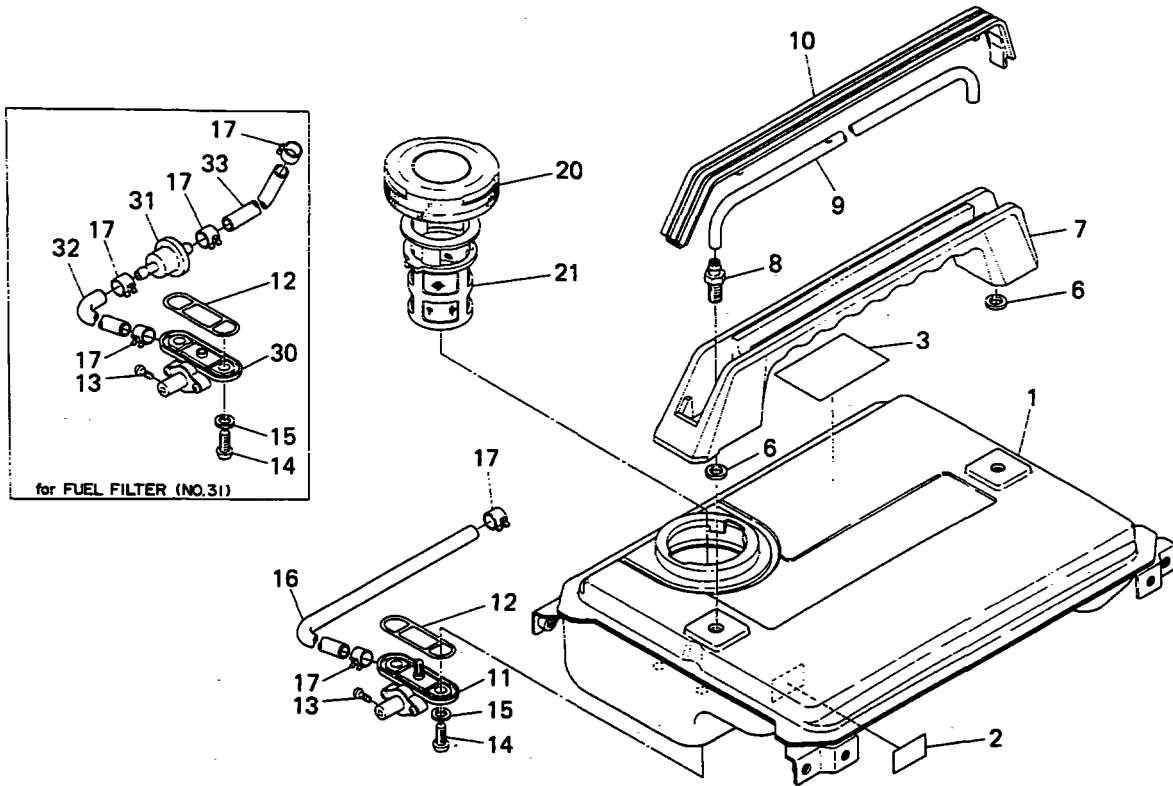

Ref No.	Description	Part Number	Q'ty	Interchangeability		Ref No.	Description	Part Number	Q'ty	Interchangeability	
				Execution						Execution	
1	FUEL TANK, complete (Color: WHITE)	358-61102-01	1			20	FUEL TANK CAP, complete	043-04300-41	1		
1	FUEL TANK, complete (Color: BLACK)	358-61101-01	1			21	FUEL FILTER, complete	064-13600-20	1		
2	FELT, tank	358-65401-13	1			*30	FUEL STRAINER ASSEMBLY Includes items 12 and 13	064-20046-01	1		
3	LABEL, caution	073-20032-20	1			31	FUEL FILTER	358-62801-01	1		
6	O-RING, tank	358-65501-03	2			32	RUBBER PIPE (4.5φx9φx220mm)	085-14500-00	1		
7	HANDLE, complete	358-65101-21	1			33	RUBBER PIPE (4.5φx9φx400mm)	085-14500-00	1		
8	BOLT, tank	358-65302-11	2								
9	BREATHER PIPE	358-65701-03	1								
10	HANDLE COVER (Color: YELLOW)	383-65201-03	1								
10	HANDLE COVER (Color: BLACK)	358-65201-13	1								
*11	FUEL COCK ASSEMBLY Includes items 12 and 13	064-20074-00	1								
12	JOINT PACKING	064-20046-30	1								
13	SCREW	004-31040-60	1								
14	SCREW	004-31061-40	2								
15	GASKET, fiber	003-71060-00	2								
16	RUBBER PIPE (4.5φx9φx620mm)	085-10400-00	1								
17	HOSE CLAMP	056-10800-20	2								
17	HOSE CLAMP For fuel filter, No. 31	056-10800-20	4								

When ordering parts; Always give the Model, Specification and Serial Number of Generator.

Fig. 2-1 CONTROL PANEL

BODY and GENERATOR PARTS

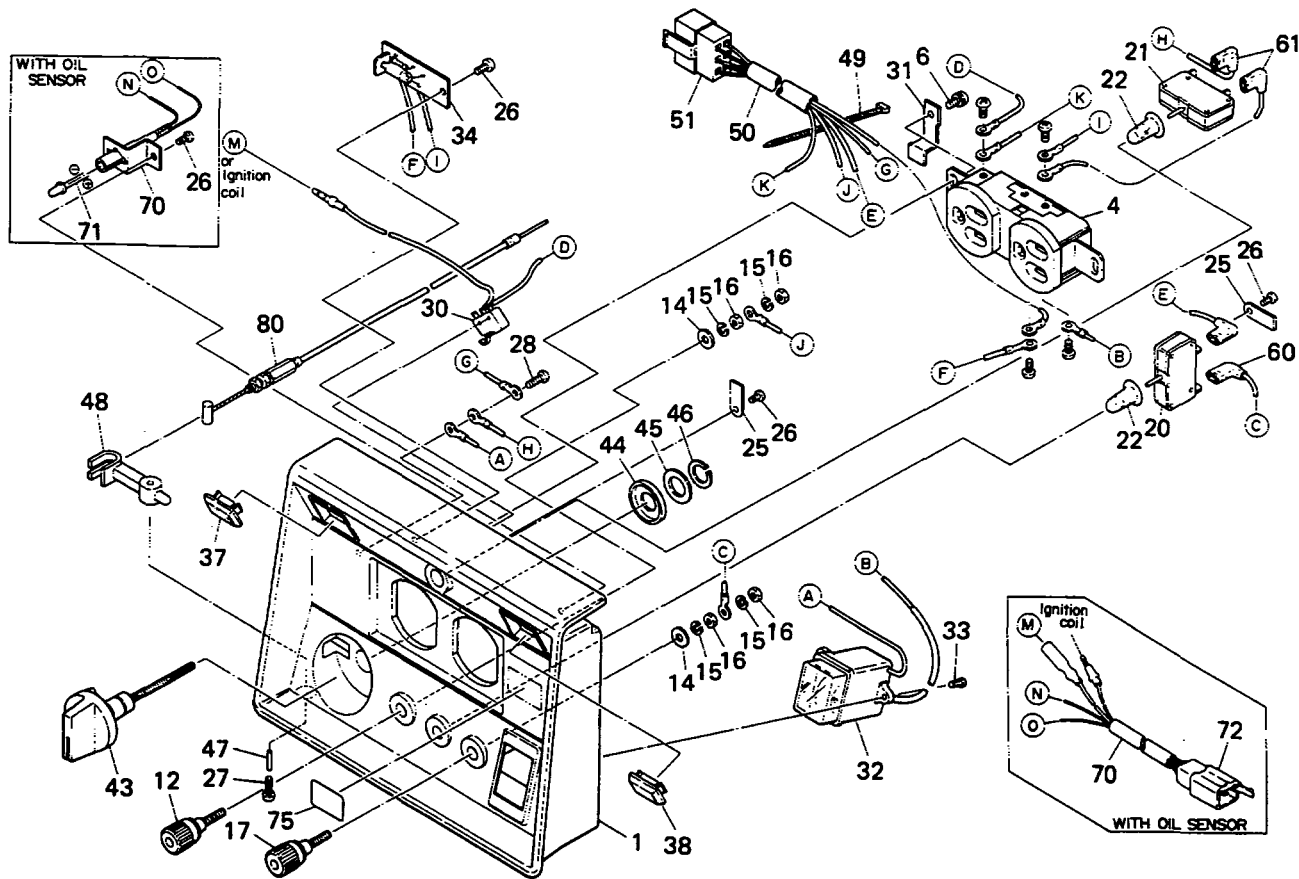

Interchangeability

Interchangeability

Ref No.	Description	Part Number	Q'ty	Execution	Ref No.	Description	Part Number	Q'ty	Execution
*1	CONTROL PANEL, complete (Mark . . . X) Includes items 1 thru 61 For 50/60Hz-110V	383-40601-01	1		4	AC RECEPTACLE (250V-15A) For 220V, 240V	383-40611-08	1	
*1	CONTROL PANEL, complete (Mark . . . W) Includes items 1 thru 61 For 60Hz-120V	383-40602-01	1		6	SCREW and WASHER ASSEMBLY	138-70251-08	2	
*1	CONTROL PANEL, complete (Mark . . . Y) Includes items 1 thru 61 For 50/60Hz-220V, 240V	383-40603-01	1		*12	TERMINAL BOLT Includes items 14 thru 16 (Color: BLACK)	358-40608-08	1	
*1	CONTROL PANEL, complete (Mark . . . X) Includes items 1 thru 72 For oil sensor, 50/60Hz-110V	383-40701-01	1		*17	TERMINAL BOLT Includes items 14 thru 16 (Color: RED)	358-40607-08	1	
*1	CONTROL PANEL, complete (Mark . . . W) Includes items 1 thru 72 For oil sensor, 60Hz-120V	383-40702-01	1		20	CIRCUIT BREAKER (10A) For DC	383-40633-08	1	
*1	CONTROL PANEL, complete (Mark . . . Y) Includes items 1 thru 72 For oil sensor, 50/60Hz-220V, 240V	383-40703-01	1		21	CIRCUIT BREAKER (4A) For 50/60Hz-110V	383-40632-08	1	
1	PANEL	383-40600-08	1		21	CIRCUIT BREAKER (3.5A) For 60Hz-120V	383-40631-08	1	
4	AC RECEPTACLE (125V-15A) For 110V, 120V	383-40610-08	1		21	CIRCUIT BREAKER (2A) For 50/60Hz-220V, 240V	383-40630-08	1	
					22	CAP	383-40750-08	2	
					25	CLAMP	358-40655-08	2	
					26	TAPPING SCREW	358-40660-08	3	
					26	TAPPING SCREW For oil sensor	358-40660-08	4	
					27	TAPPING SCREW	358-40669-08	1	
					28	SCREW and WASHER ASSEMBLY	138-70251-08	1	

When ordering parts; Always give the Model, Specification and Serial Number of Generator.

Fig. 2-1 CONTROL PANEL

BODY and GENERATOR PARTS

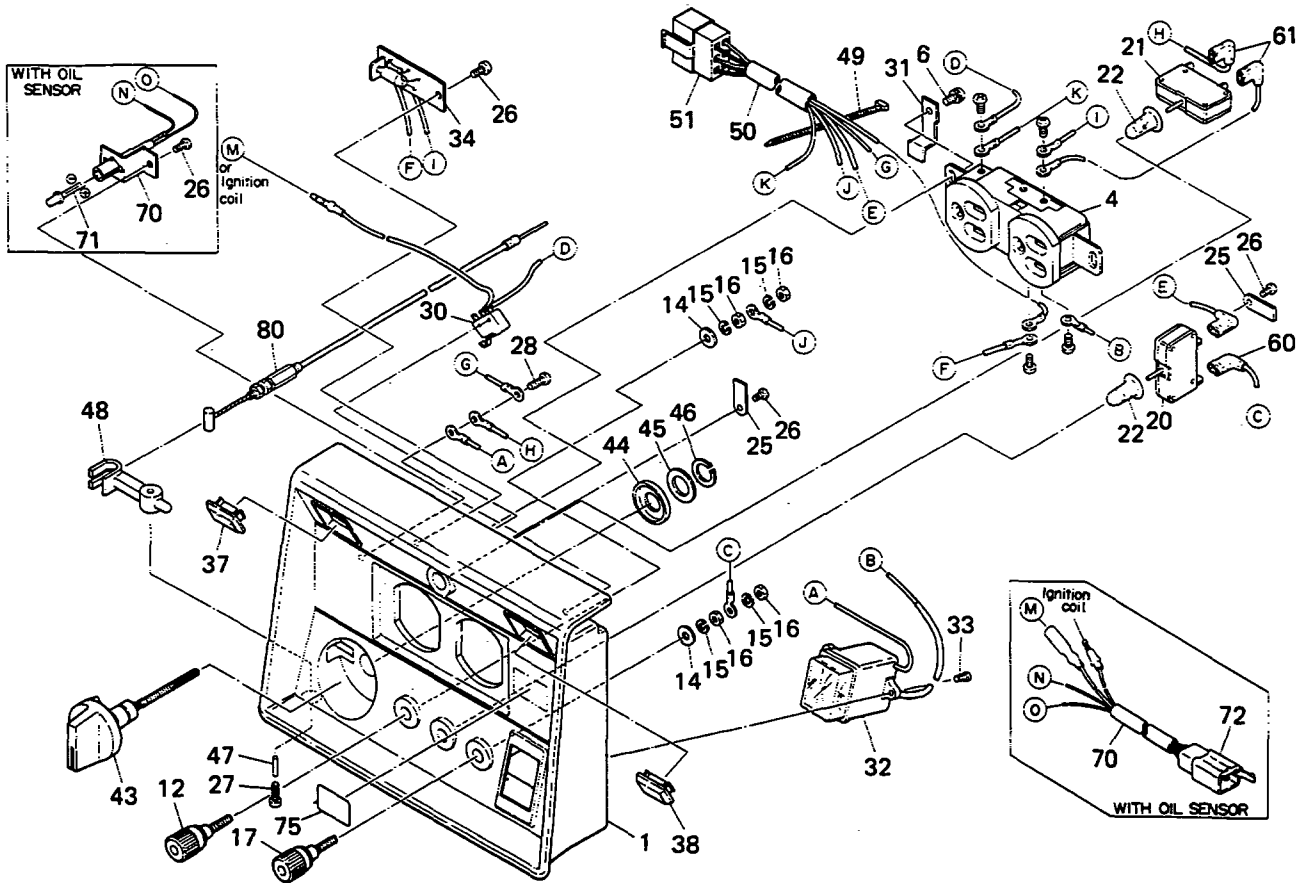

Interchangeability

Interchangeability

Ref No.	Description	Part Number	Q'ty	Execution	Ref No.	Description	Part Number	Q'ty	Execution
30	MICRO SWITCH	358-40643-08	1		60	WIRE 11, complete	383-40700-08	1	
31	CLAMP	383-40751-08	1		61	WIRE 12, complete	383-40701-08	2	
32	VOLT METER For 110V, 120V	383-40640-08	1		*70	WIRE HARNESS, complete Includes items 71 and 72 For oil sensor	358-40646-08	1	
32	VOLT METER For 220V, 240V	383-40641-08	1		71	L.E.D.	358-41131-08	1	
33	TAPPING SCREW	358-40661-08	2		72	CONNECTOR	358-41132-08	1	
34	LAMP For 110V, 120V	383-40645-08	1		75	LABEL, Hz-V For 50/60Hz-110V	383-95302-03	1	
34	LAMP For 220V, 240V	383-40646-08	1		75	LABEL, Hz-V For 50/60Hz-220V	383-95303-03	1	
37	CAP (Color: GREEN)	358-40651-08	1		75	LABEL, Hz-V For 50/60Hz-240V	383-95305-03	1	
38	CAP (Color: BLACK)	358-40650-08	1		75	LABEL, Hz-V For 60Hz-120V	358-95313-03	1	
38	CAP (Color: CLEAR) For oil sensor	358-41133-08	1		80	CHOKE WIRE, complete	383-45101-01	1	
43	KNOB	358-40644-08	1						
44	COVER	358-40659-08	1						
45	WASHER	358-40687-08	1						
46	CLIP	358-40653-08	1						
47	PIN	358-40658-08	1						
48	LEVER	383-40752-08	1						
49	WIRE BAND	056-30000-20	2						
*50	WIRE HARNESS Includes item 51	383-40650-08	1						
51	CONNECTOR	358-21021-08	1						

When ordering parts; Always give the Model, Specification and Serial Number of Generator.

Fig. 2-2 CONTROL PANEL (SPECIAL RECEPTACLE)

BODY and GENERATOR PARTS

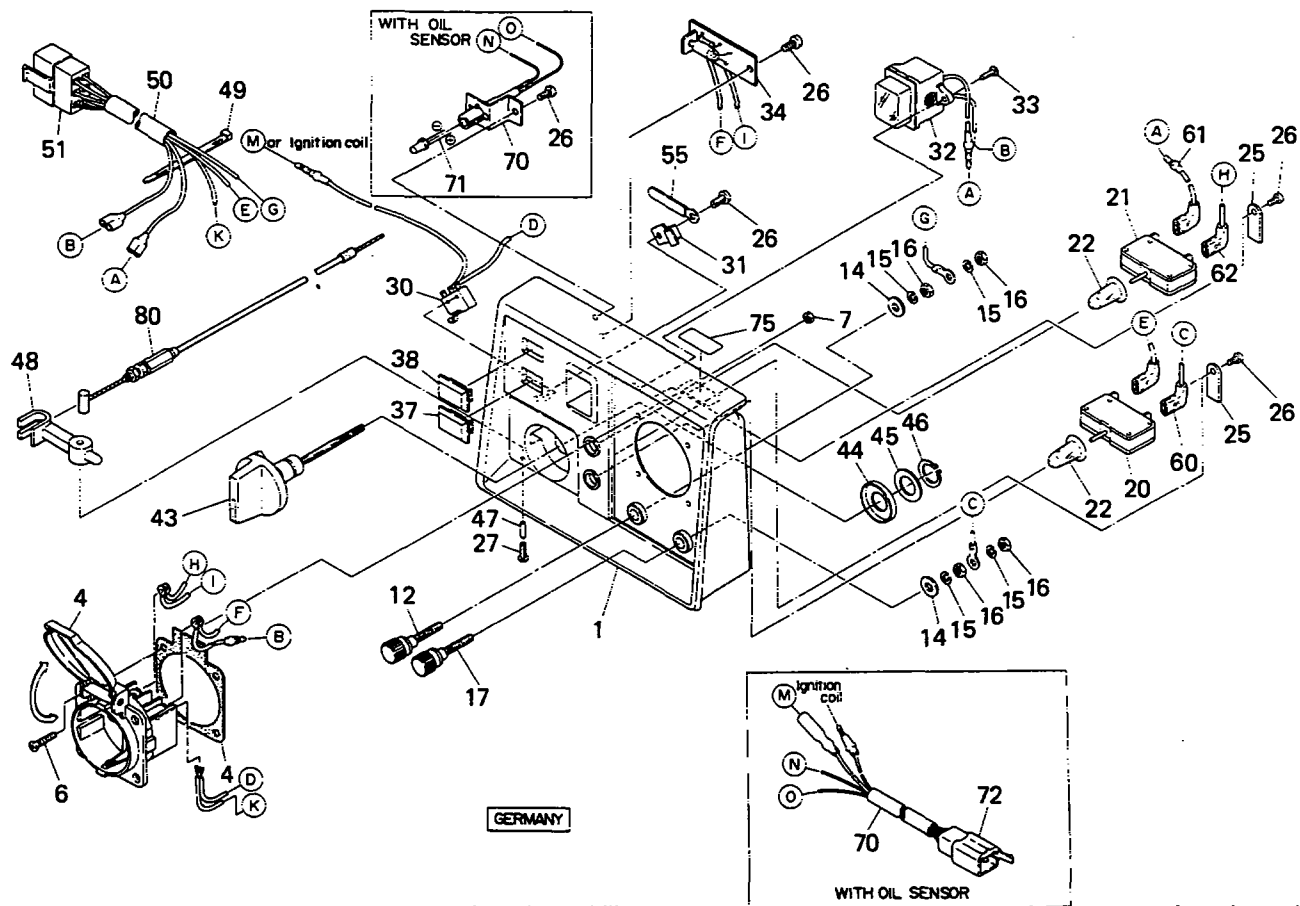

GERMANY

Interchangeability

Interchangeability

Ref No.	Description	Part Number	Q'ty	Execution	Ref No.	Description	Part Number	Q'ty	Execution
*1	CONTROL PANEL, complete Includes items 1 thru 64 For 50/60Hz-220V, 240V, (Germany)	383-40611-01	1		*1	CONTROL PANEL, complete Includes items 1 thru 72 For oil sensor, 50/60Hz- 220V, 240V, (England, BF)	383-40751-01	1	
*1	CONTROL PANEL, complete Includes items 1 thru 64 For 50/60Hz-240V, (Australia)	383-40650-01	1		*1	CONTROL PANEL, complete Includes items 1 thru 72 For oil sensor, 50/60Hz- 220V, (Switzerland)	383-40752-01	1	
*1	CONTROL PANEL, complete Includes items 1 thru 64 For 50/60Hz-220V, 240V, (England, BF)	383-40651-01	1		*1	CONTROL PANEL, complete Includes items 1 thru 72 For oil sensor, 50/60Hz- 220V, (France)	383-40710-01	1	
*1	CONTROL PANEL, complete Includes items 1 thru 64 For 50/60Hz-220V, (Switzerland)	383-40652-01	1		*1	CONTROL PANEL, complete Includes items 1 thru 72 For oil sensor, 50/60Hz- 110V, (England, BS4343)	383-40753-01	1	
*1	CONTROL PANEL, complete Includes items 1 thru 64 For 50/60Hz-220V, (France)	383-40610-01	1		1	PANEL For Germany	383-40601-08	1	
*1	CONTROL PANEL, complete Includes items 1 thru 64 For 50/60Hz-110V, (England, BS4343)	383-40653-01	1		1	PANEL For France	383-40603-08	1	
*1	CONTROL PANEL, complete Includes items 1 thru 72 For oil sensor, 50/60Hz- 220V, 240V, (Germany)	383-40711-01	1		1	PANEL For Australia, England and Switzerland	383-40602-08	1	
*1	CONTROL PANEL, complete Includes items 1 thru 72 For oil sensor, 50/60Hz- 240V, (Australia)	383-40750-01	1		2	PLATE For Australia	358-40670-08	1	
					2	PLATE For England (BF)	358-40679-08	1	
					2	PLATE For Switzerland	358-40674-08	1	

When ordering parts: Always give the Model, Specification and Serial Number of Generator.

Fig. 2-2 CONTROL PANEL (SPECIAL RECEPTACLE)

BODY and GENERATOR PARTS

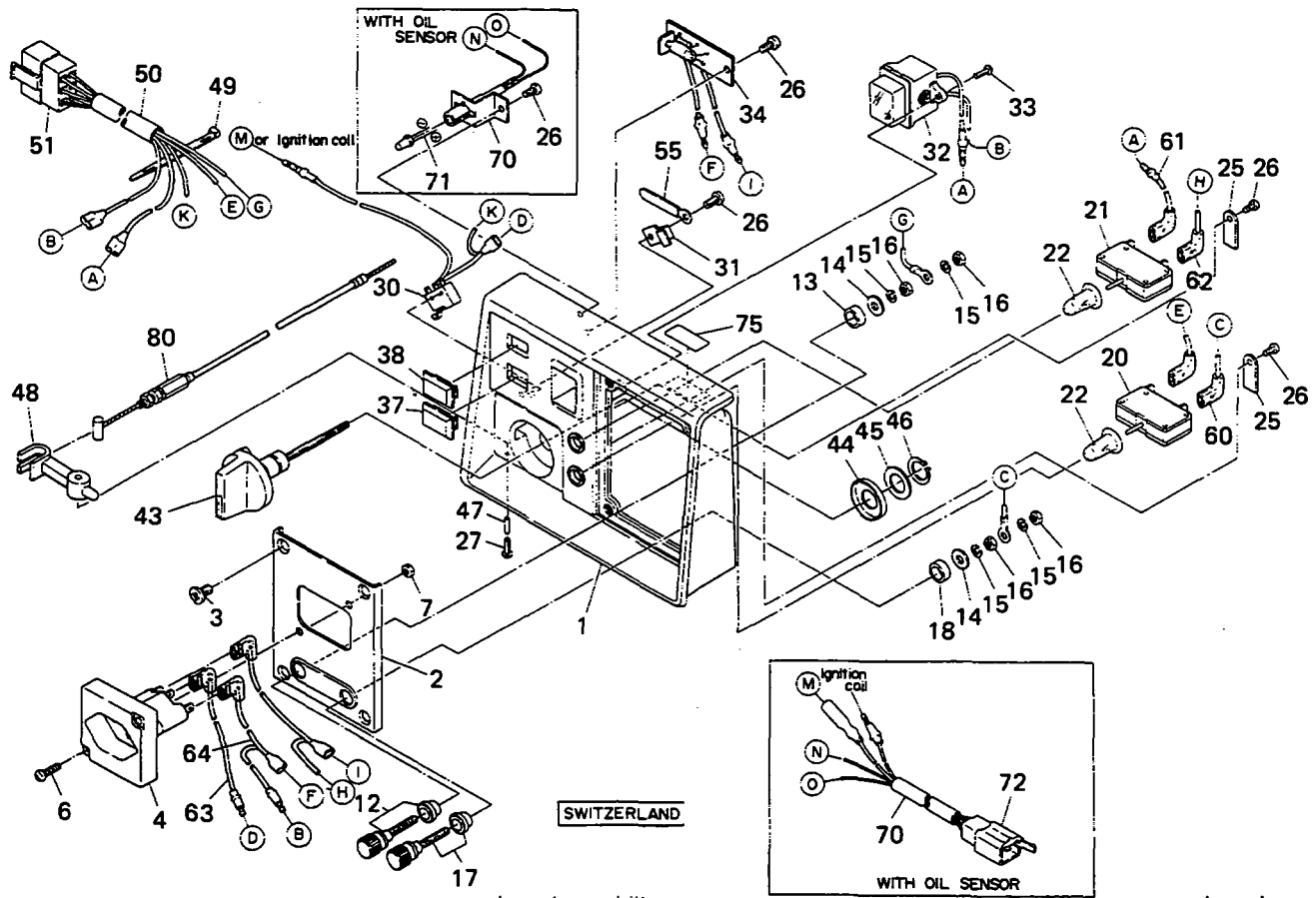

SWITZERLAND

Interchangeability

Interchangeability

Ref No.	Description	Part Number	Q'ty	Execution	Ref No.	Description	Part Number	Q'ty	Execution
2	PLATE For England (BS4343)	358-40684-08	1		7	NUT For England (BF) and Switzerland	358-40680-08	2	
3	SCREW	358-40668-08	4		7	NUT For Germany and France	358-40680-08	4	
4	AC RECEPTACLE For Germany	358-40614-08	1		7	NUT For England (BS4343)	358-40686-08	4	
4	AC RECEPTACLE For Australia	358-40613-08	1		7	SCREW For Australia	358-40682-08	2	
4	AC RECEPTACLE For England (BF)	358-40616-08	1		*12	TERMINAL BOLT Includes items 13 thru 16 (Color: BLACK)	358-40608-08	1	
4	AC RECEPTACLE For Switzerland	358-40617-08	1		*17	TERMINAL BOLT Includes items 14 thru 16 and 18 (Color: RED)	358-40607-08	1	
4	AC RECEPTACLE For France	358-40612-08	1		20	CIRCUIT BREAKER (10A)	383-40633-08	1	
4	AC RECEPTACLE For England (BS4343)	358-45725-08	1		21	CIRCUIT BREAKER (2A) For 50/60Hz-220V, 240V	383-40630-08	1	
5	BRACKET For Australia	358-40681-08	2		21	CIRCUIT BREAKER (4A) For 50/60Hz-110V	383-40632-08	1	
6	SCREW For Germany	383-40753-08	4		22	CAP	383-40750-08	2	
6	SCREW For Australia	358-40671-08	2		25	CLAMP	358-40655-08	2	
6	SCREW For England (BF) and Switzerland	358-40675-08	2		26	TAPPING SCREW	015-00400-31	4	
6	SCREW For France	358-40675-08	4		26	TAPPING SCREW For oil sensor	015-00400-31	5	
6	SCREW For England (BS4343)	358-40685-08	4		27	TAPPING SCREW	358-40669-08	1	
					30	MICRO SWITCH	358-40643-08	1	

When ordering parts: Always give the Model, Specification and Serial Number of Generator.

Fig. 3-1 GENERATOR (For 50/60 Hz)

BODY and GENERATOR PARTS

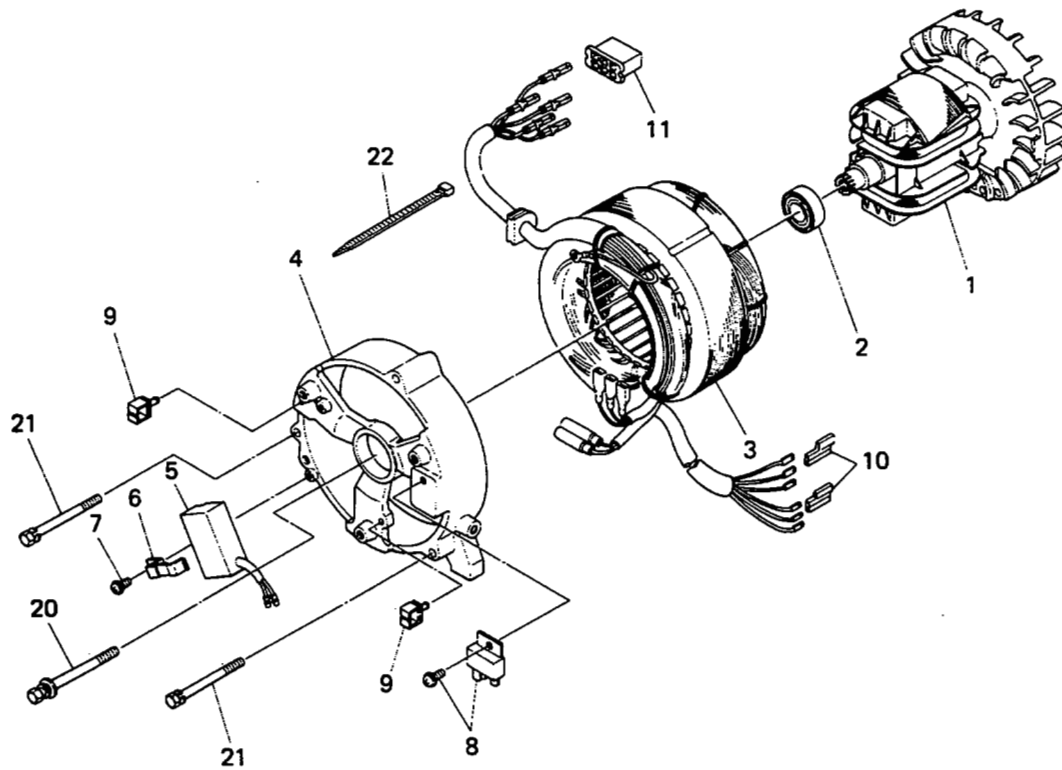

Ref No.	Description	Part Number	Q'ty	Execution	Interchangeability	
					Ref No.	Description
*1	ROTOR, complete Includes item 2	383-21161-01	1			
2	BALL BEARING	358-21015-08	1			
*3	STATOR, complete Includes items 4 thru 22 For 110V	383-21251-01	1			
*3	STATOR, complete Includes items 4 thru 22 For 220V	383-21651-01	1			
*3	STATOR, complete Includes items 4 thru 22 For 240V	383-21851-01	1			
5	CONDENSER	383-21000-08	1			
6	BAND	383-21052-08	1			
7	SCREW	383-21051-08	2			
8	RECTIFIER, complete	358-21006-08	1			
9	CLAMP	383-21050-08	2			
10	CONNECTOR	383-21030-08	2			
11	CONNECTOR	358-21020-08	1			
20	BOLT and WASHER ASSEMBLY	013-00800-90	1			
21	BOLT and WASHER ASSEMBLY	013-00600-80	3			
22	WIRE BAND	056-30000-20	1			

When ordering parts; Always give the Model, Specification and Serial Number of Generator.

Fig. 3-2 GENERATOR (For 60 Hz)

BODY and GENERATOR PARTS

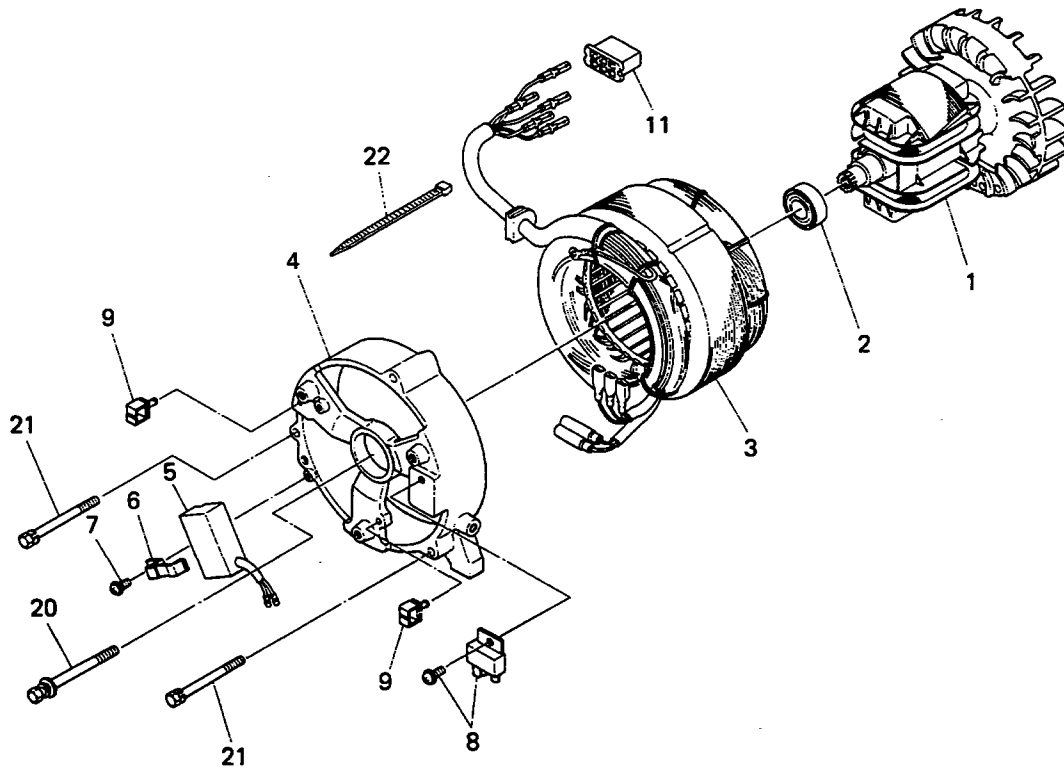

Ref No.	Description	Part Number	Q'ty	Interchangeability		Ref No.	Description	Part Number	Q'ty	Interchangeability	
				Execution	Execution					Execution	Execution
*1	ROTOR complete Includes item 2	383-21161-01	1								
2	BALL BEARING	358-21015-08	1								
*3	STATOR, complete Includes items 4 thru 22 For 120V	383-22351-01	1								
5	CONDENSER	383-21000-08	1								
6	BAND	383-21052-08	1								
7	SCREW	383-21051-08	2								
8	RECTIFIER, complete	358-21006-08	1								
9	CLAMP	383-21050-08	2								
11	CONNECTOR	358-21020-08	1								
20	BOLT and WASHER ASSEMBLY	013-00800-90	1								
21	BOLT and WASHER ASSEMBLY	013-00600-80	3								
22	WIRE BAND	056-30000-20	1								

When ordering parts; Always give the Model, Specification and Serial Number of Generator.

Fig. 4 COVER

BODY and GENERATOR PARTS

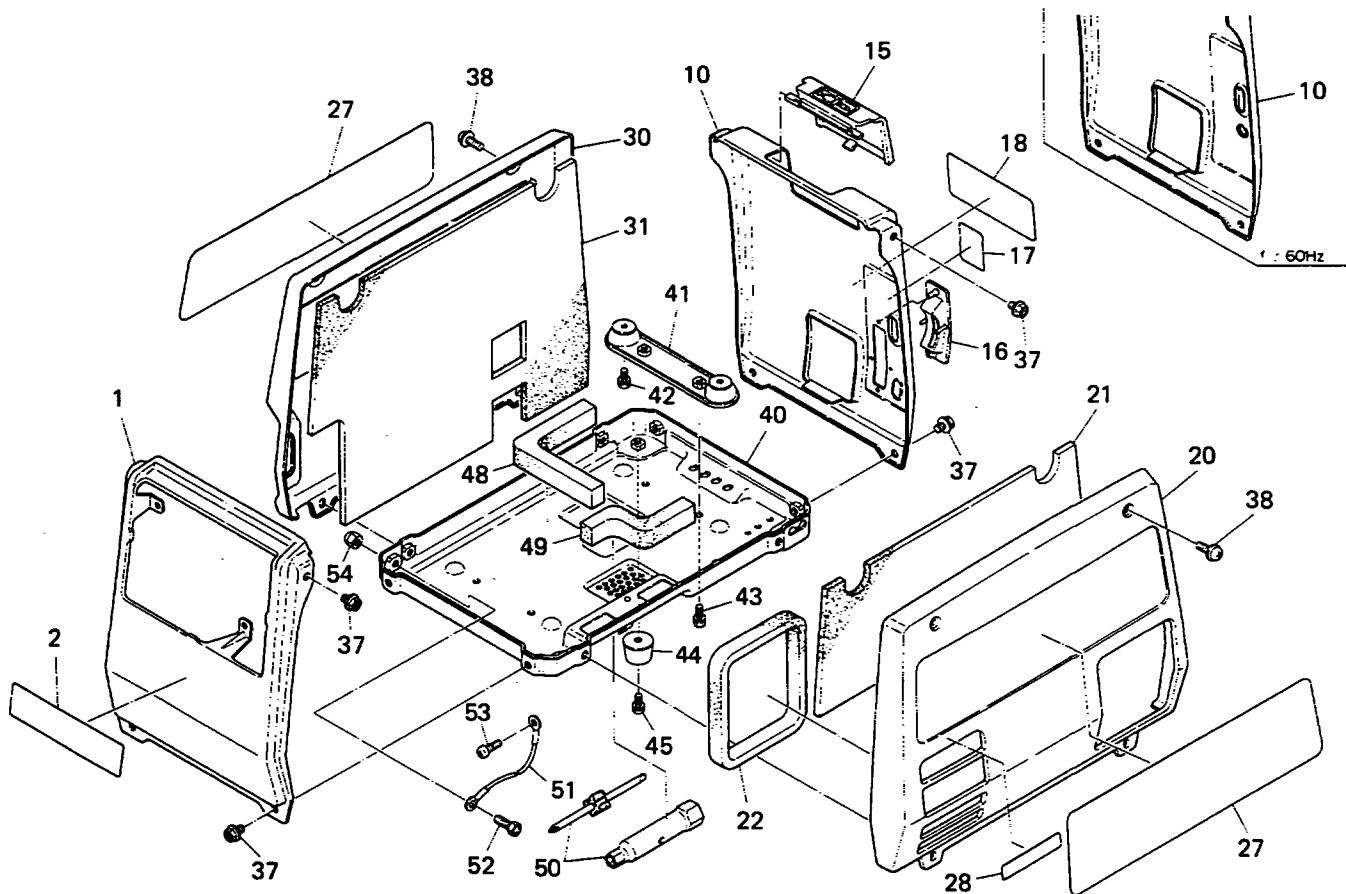

Interchangeability

Interchangeability

Ref No.	Description	Part Number	Q'ty	Execution	Ref No.	Description	Part Number	Q'ty	Execution
1	FRONT COVER, complete (Color: WHITE)	358-53001-31	1		18	LABEL, spec. For 60Hz-120V	383-91907-03	1	
1	FRONT COVER, complete (Color: BLACK)	358-53002-31	1		18	LABEL, spec. For 50/60Hz-220V, (France)	383-91909-03	1	
2	LABEL, trade mark	383-91704-03	1		*20	SIDE COVER (R), complete Includes item 21 (Color: RED)	383-51102-01	1	
10	REAR COVER, complete (Color: WHITE) For 50/60Hz	383-50602-01	1		*20	SIDE COVER (R), complete Includes item 21 (Color: YELLOW)	383-51101-01	1	
10	REAR COVER, complete (Color: BLACK) For 50/60Hz	383-50601-01	1		21	SPONGE (R)	383-55301-03	1	
10	REAR COVER, complete (Color: WHITE) For 60Hz	383-50702-01	1		22	SEAL, exhaust	383-55501-03	1	
10	REAR COVER, complete (Color: BLACK) For 60Hz	383-50701-01	1		27	LABEL, trade mark	383-91703-03	2	
15	PLUG COVER	383-55101-03	1		27	LABEL, trade mark For France	383-91705-03	2	
16	COVER, Hz selector For 50/60Hz	383-55601-03	1		28	LABEL, spark arrester For U.S.A.	358-95304-03	1	
17	LABEL, 50/60Hz For 50/60Hz	073-20032-40	1		*30	SIDE COVER (L), complete Includes item 31 (Color: RED)	358-53401-31	1	
18	LABEL, spec. For 50/60Hz-110V	383-91902-03	1		*30	SIDE COVER (L), complete Includes item 31 (Color: YELLOW)	358-53402-31	1	
18	LABEL, spec. For 50/60Hz-220V	383-91903-03	1		31	SPONGE (L)	383-55302-03	1	
18	LABEL, spec. For 50/60Hz-240V	383-91905-03	1		37	FLANGE BOLT	011-00600-60	8	
					38	FLANGE SCREW	358-55201-03	8	
					40	BASE PLATE, complete	358-30601-51	1	

When ordering parts; Always give the Model, Specification and Serial Number of Generator.

Fig. 4 COVER

BODY and GENERATOR PARTS

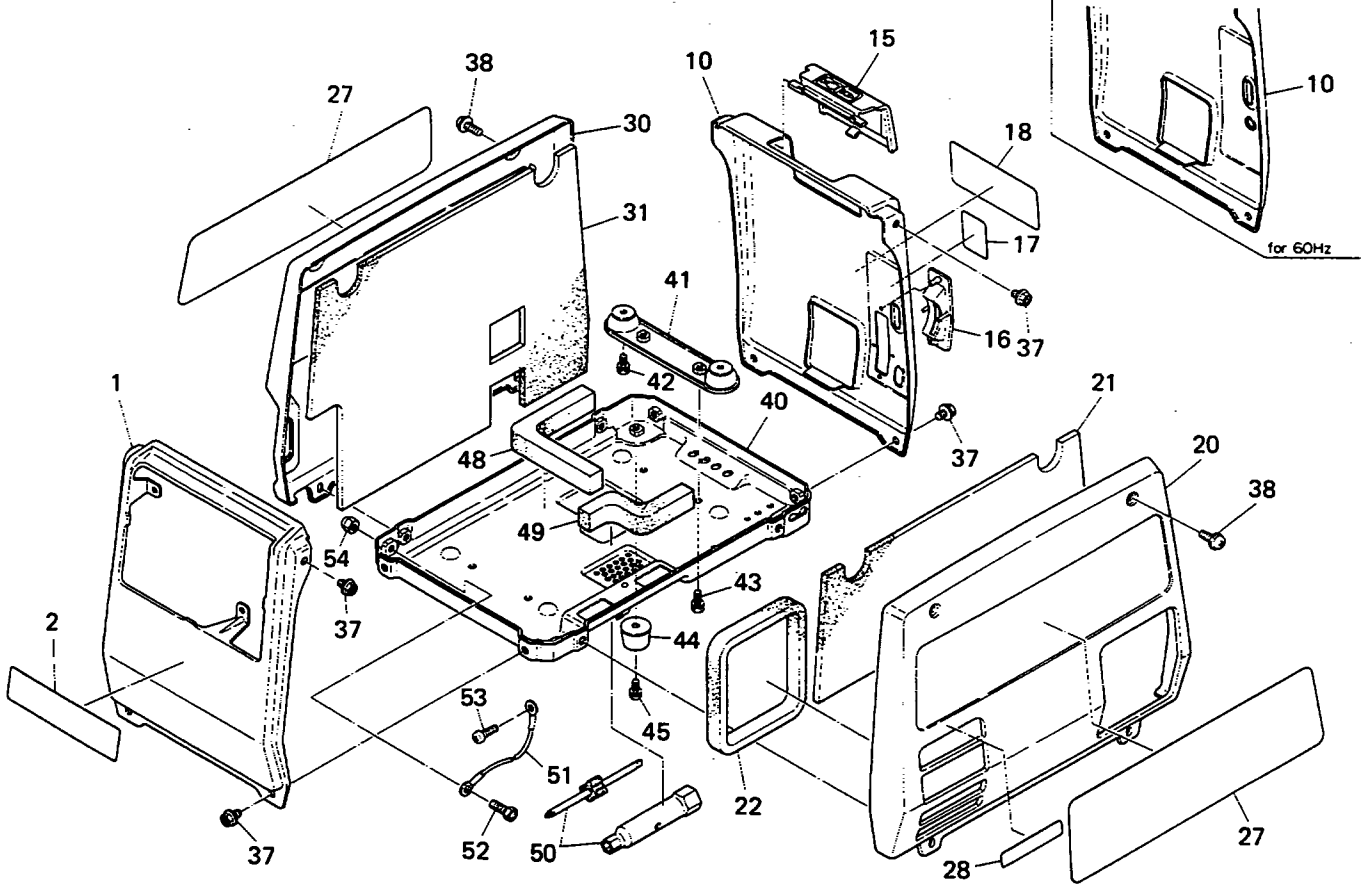

Interchangeability

Interchangeability

Ref No.	Description	Part Number	Q'ty	Execution	Ref No.	Description	Part Number	Q'ty	Execution
41	MOUNT (A), complete	358-30101-11	2						
42	BOLT and WASHER ASSEMBLY	001-14061-20	4						
43	BOLT and WASHER ASSEMBLY	001-16051-00	4						
44	MOUNT (B), complete	358-30201-01	4						
45	SCREW and WASHER ASSEMBLY	004-35051-00	4						
48	SEAL 1, base	383-36101-03	1						
49	SEAL 2, base	383-36102-03	1						
50	ACCESSORY TOOL KIT	358-90301-10	1						
51	EARTH WIRE, complete	358-35102-01	1						
52	BOLT	001-65061-20	1						
53	SCREW, pan head	004-31060-80	1						
54	CROWN NUT	002-43060-01	1						

When ordering parts: Always give the Model, Specification and Serial Number of Generator.

Fig. 5-1 CRANKCASE

ENGINE PARTS

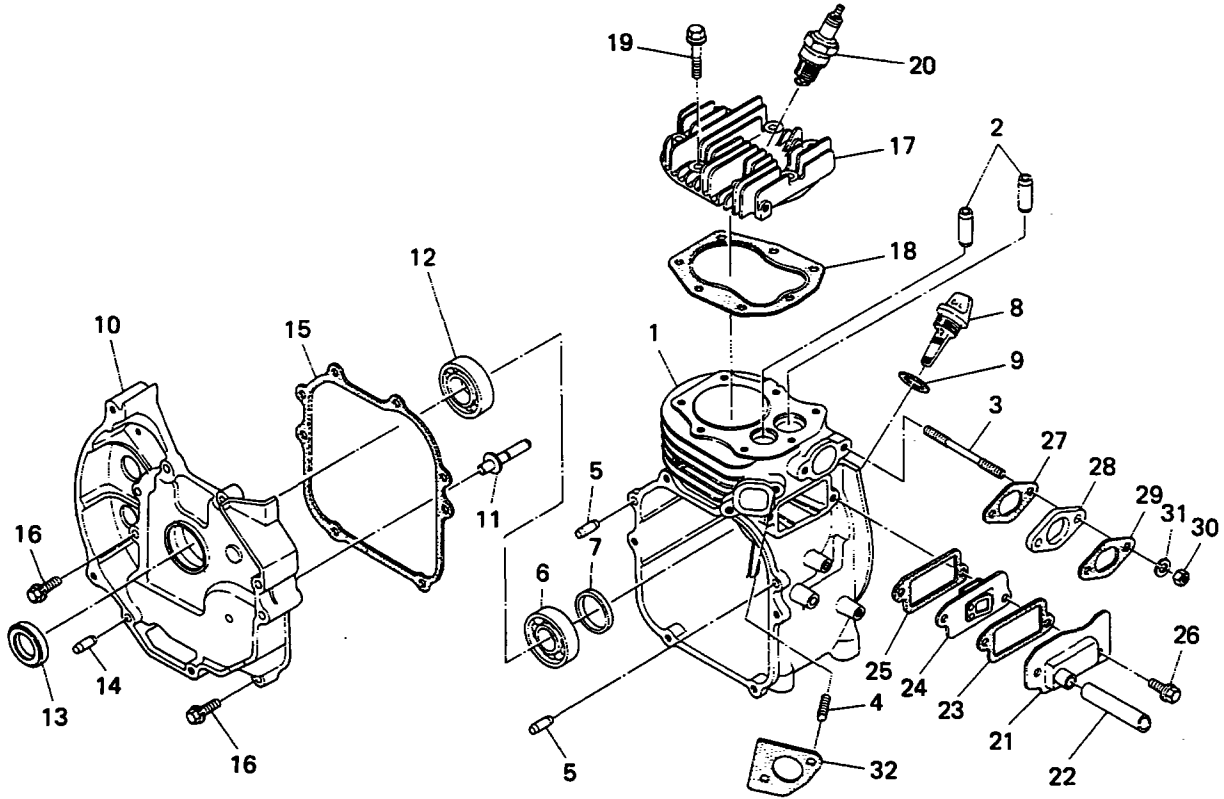

Interchangeability					Interchangeability				
Ref No.	Description	Part Number	Q'ty	Execution	Ref No.	Description	Part Number	Q'ty	Execution
*1	CRANKCASE, complete Includes items 2 thru 7	230-10201-11	1		22	RUBBER PIPE (8φx11φx48mm)	085-10800-00	1	
2	VALVE GUIDE, over size	230-14202-03	2		23	GASKET, tappet cover	230-16006-03	1	
3	STUD	010-50601-60	2		24	BREATHER PLATE, complete	230-14401-01	1	
4	STUD	010-50601-70	2		25	GASKET, breather plate	230-16007-03	1	
5	DOWEL PIN	031-00600-10	2		26	FLANGE BOLT	011-00600-20	2	
6	BALL BEARING (BB-6203)	060-01700-30	1		27	GASKET, insulator	230-35901-03	1	
7	PLUG, rubber	230-17101-03	1		28	INSULATOR	230-32901-03	1	
8	OIL GAUGE	230-63601-03	1		29	GASKET 2, insulator	230-35902-03	1	
9	GASKET	021-31600-10	1		30	NUT	002-17060-00	2	
*10	MAIN BEARING COVER, complete Includes items 11 thru 14	230-11201-21	1		31	SPRING WASHER	003-20060-00	2	
12	BALL BEARING (BB-6004)	060-02001-00	1		32	GASKET, complete, muffler cover	230-35202-01	1	
13	OIL SEAL (TB-20φx32φx6mm)	044-02000-70	1		*	GASKET SET Includes items 9, 15, 18, 23, 25, 27, 29, 32, Muffler-12 and Air Cleaner-7	230-99002-07	1	
14	DOWEL PIN	031-00600-10	2						
15	GASKET, bearing cover	230-16001-03	1						
16	BOLT and WASHER ASSEMBLY	001-13062-50	5						
17	CYLINDER HEAD	230-13101-03	1						
18	GASKET, complete, head	230-15001-01	1						
19	FLANGE BOLT	011-00600-90	7						
20	SPARK PLUG (NGK-BMR4A)	065-01403-80	1						
21	TAPPET COVER, complete	230-14301-01	1						

When ordering parts; Always give the Model, Specification and Serial Number of Generator.

Fig. 5-2 CRANKCASE (with OIL SENSOR)

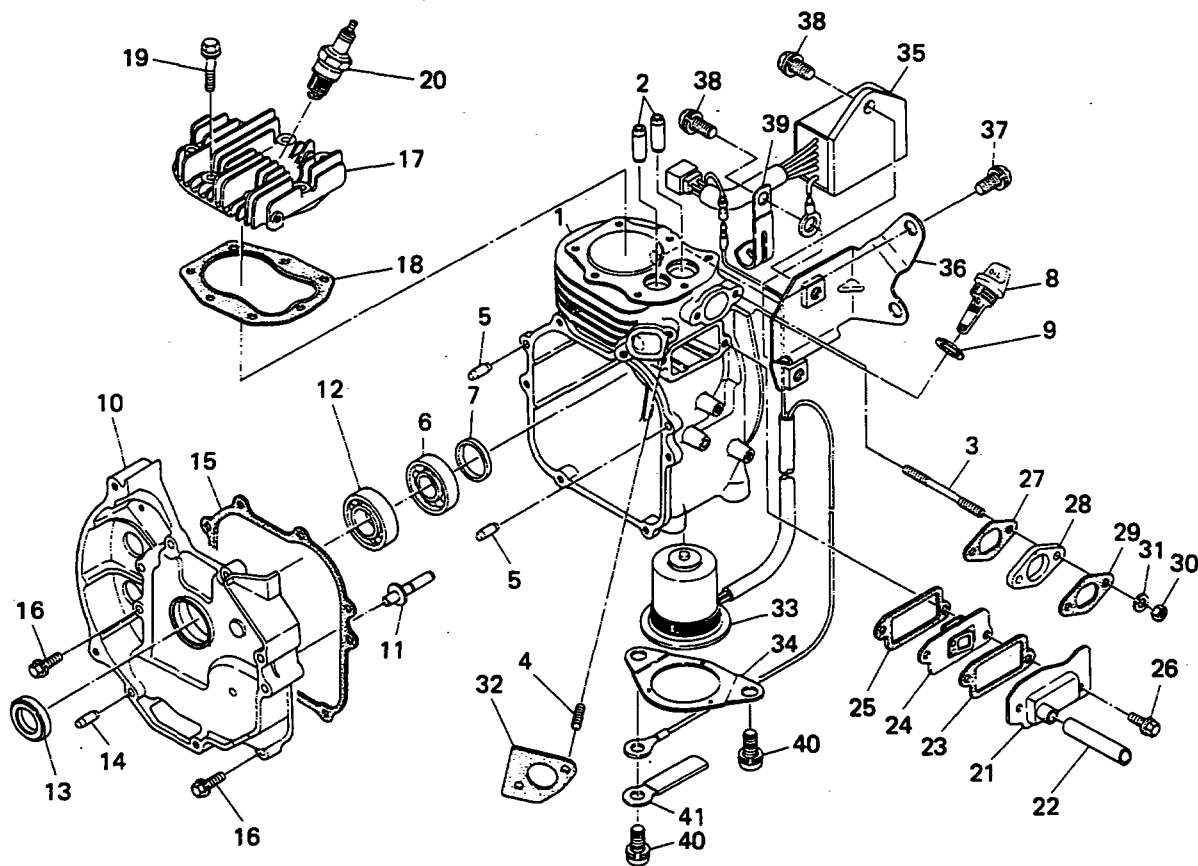

Ref No.	Description	Part Number	Q'ty	Execution	Interchangeability				
					Ref No.	Description	Part Number	Q'ty	Execution
*1	CRANKCASE, complete Includes items 2 thru 7	230-10202-01	1		22	RUBBER PIPE (8φ×11φ×48mm)	085-10800-00	1	
2	VALVE GUIDE, over size	230-14202-03	2		23	GASKET, tappet cover	230-16006-03	1	
3	STUD	010-50601-60	2		24	BREATHER PLATE, complete	230-14401-01	1	
4	STUD	010-50601-70	2		25	GASKET, breather plate	230-16007-03	1	
5	DOWEL PIN	031-00600-10	2		26	FLANGE BOLT	011-00600-20	2	
6	BALL BEARING (BB-6203)	060-01700-30	1		27	GASKET, insulator	230-35901-03	1	
7	PLUG, rubber	230-17101-03	1		28	INSULATOR	230-32901-03	1	
8	OIL GAUGE	230-63601-03	1		29	GASKET 2, insulator	230-35902-03	1	
9	GASKET	021-31600-10	1		30	NUT	002-17060-00	2	
*10	MAIN BEARING COVER, complete Includes items 11 thru 14	230-11201-21	1		31	SPRING WASHER	003-20060-00	2	
12	BALL BEARING (BB-6004)	060-02001-00	1		32	GASKET, complete, muffler cover	230-35202-01	1	
13	OIL SEAL (TB-20φ×32φ×6mm)	044-02000-70	1		33	OIL SENSOR, complete	230-76301-11	1	
14	DOWEL PIN	031-00600-10	2		34	SENSOR RETAINER	230-75801-03	1	
15	GASKET, bearing cover	230-16001-03	1		35	CONTROLLER UNIT	230-76201-02	1	
16	BOLT and WASHER ASSEMBLY	001-13062-50	5		36	BRACKET, complete	230-78201-01	1	
17	CYLINDER HEAD	230-13101-03	1		37	BOLT and WASHER ASSEMBLY	001-11061-20	2	
18	GASKET, complete, head	230-15001-01	1		38	SCREW and WASHER ASSEMBLY	004-36061-60	2	
19	FLANGE BOLT	011-00600-90	7		39	CLAMP	056-60002-50	1	
20	SPARK PLUG (NGK-BMR4A)	065-01403-80	1		40	SCREW and WASHER ASSEMBLY	004-35061-00	2	
21	TAPPET COVER, complete	230-14301-01	1		41	CLAMP	226-75101-03	1	

When ordering parts; Always give the Model, Specification and Serial Number of Generator.

Fig. 5-2 CRANKCASE (with OIL SENSOR)

ENGINE PARTS

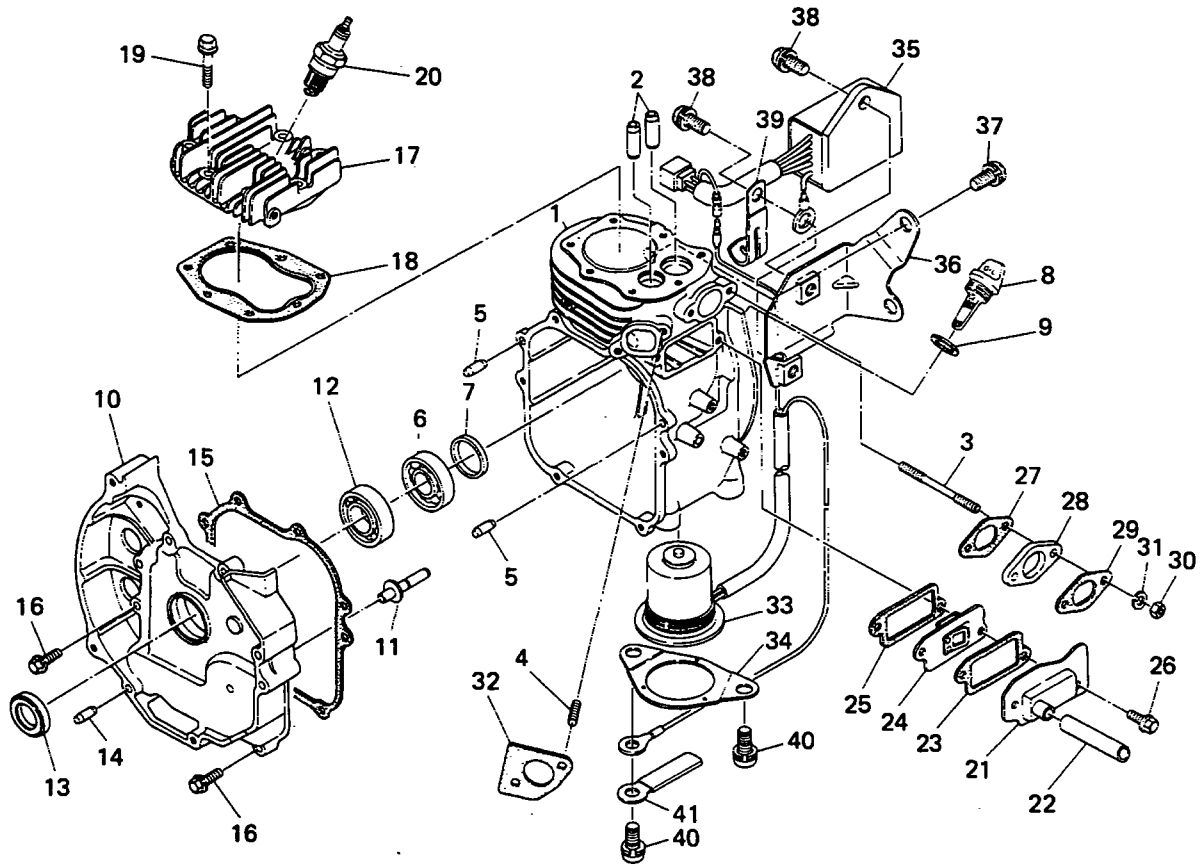

Interchangeability

Interchangeability

Ref No.	Description	Part Number	Q'ty	Execution	Ref No.	Description	Part Number	Q'ty	Execution
*	GASKET SET Includes items 9, 15, 18, 23, 25, 27, 29, 32 Muffler-12 and Air Cleaner-7	230-99002-07	1						

When ordering parts; Always give the Model, Specification and Serial Number of Generator.

Fig. 6 CRANKSHAFT, PISTON and CAMSHAFT

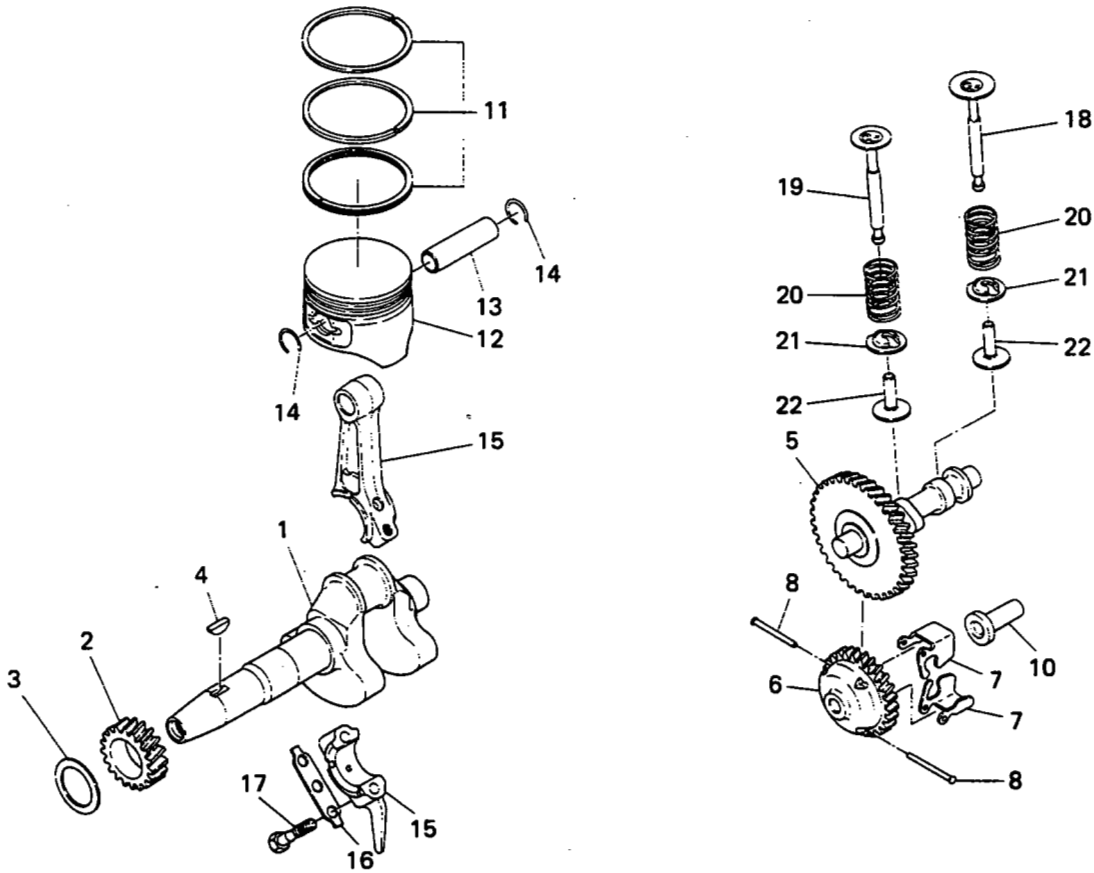

Ref No.	Description	Part Number	Q'ty	Interchangeability		Ref No.	Description	Part Number	Q'ty	Interchangeability	
				Execution						Execution	
*1	CRANKSHAFT, complete Includes item 2	230-20301-01	1			18	INTAKE VALVE	230-33401-03	1		
3	SPACER, $t=0.8$	023-02001-00	1			19	EXHAUST VALVE	230-33501-03	1		
3	SPACER, $t=1.0$	023-02001-10	1			20	VALVE SPRING	230-33601-03	2		
3	SPACER, $t=1.2$	023-02001-20	1			21	SPRING RETAINER	230-33701-03	2		
4	WOODRUFF KEY	005-32042-01	1			22	TAPPET	230-33301-03	2		
5	CAMSHAFT	230-31801-03	1								
*6	GOVERNOR GEAR, complete Includes items 7 and 8	230-45003-01	1								
10	GOVERNOR SLEEVE	205-41901-03	1								
11	PISTON RING SET, standard	230-23501-07	1								
11	PISTON RING SET, over size 0.25mm	230-23502-07	1								
11	PISTON RING SET, over size 0.50mm	230-23503-07	1								
12	PISTON, standard	230-23401-03	1								
12	PISTON, over size 0.25mm	230-23402-03	1								
12	PISTON, over size 0.50mm	230-23403-03	1								
13	PISTON PIN	230-23301-03	1								
14	CLIP	056-51100-10	2								
*15	CONNECTING ROD ASSEMBLY Includes items 16 and 17	230-22501-00	1								
16	ROD LOCK WASHER	230-23201-03	1								
17	BOLT, connecting rod	230-23001-03	2								

When ordering parts; Always give the Model, Specification and Serial Number of Generator.

Fig. 7-1 GOVERNOR (For 50/60 Hz)

ENGINE PARTS

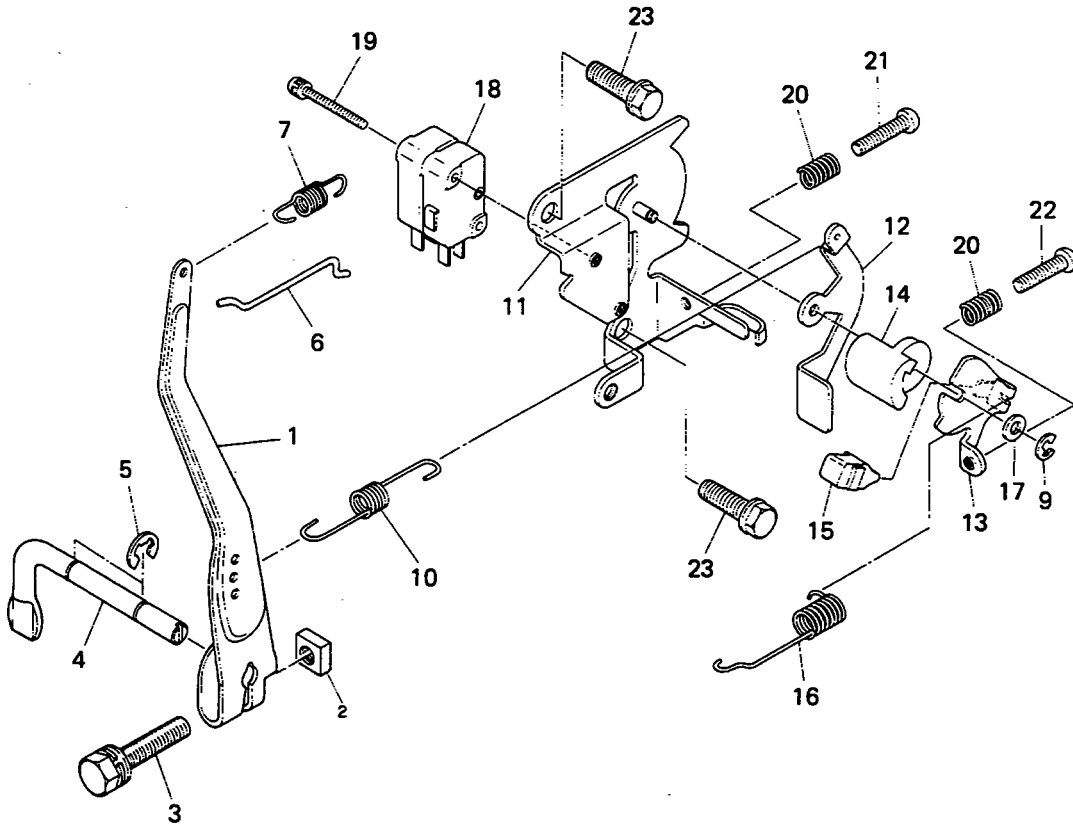

Interchangeability

Interchangeability

Ref No.	Description	Part Number	Q'ty	Execution	Ref No.	Description	Part Number	Q'ty	Execution
1	GOVERNOR LEVER, complete	230-42301-01	1		23	BOLT and WASHER ASSEMBLY	001-10061-20	2	
2	NUT	018-60600-20	1						
3	BOLT and WASHER ASSEMBLY	001-14062-50	1						
4	GOVERNOR SHAFT	230-42201-03	1						
5	CLIP	003-13050-00	2						
6	GOVERNOR ROD	230-42701-01	1						
7	ROD SPRING	230-42801-01	1						
9	CLIP	056-50300-10	1						
10	GOVERNOR SPRING	230-42505-01	1						
11	CONTROL BRACKET UNIT	230-46002-02	1						
12	CONTROL LEVER 1	230-43403-03	1						
13	CONTROL LEVER 2	230-43404-03	1						
14	CAM, switch	230-43902-03	1						
15	KNOB, Hz selector	230-43903-03	1						
16	SPRING, lever	230-49005-01	1						
17	WASHER	003-10040-00	1						
18	MICRO SWITCH	230-49501-01	2						
19	SCREW and WASHER ASSEMBLY	004-35032-50	2						
20	SPRING, adjust	230-49006-01	2						
21	SCREW, pan head	004-31420-00	1						
22	SCREW, pan head	004-31041-40	1						

When ordering parts: Always give the Model, Specification and Serial Number of Generator.

Fig. 7-2 GOVERNOR (For 60 Hz)

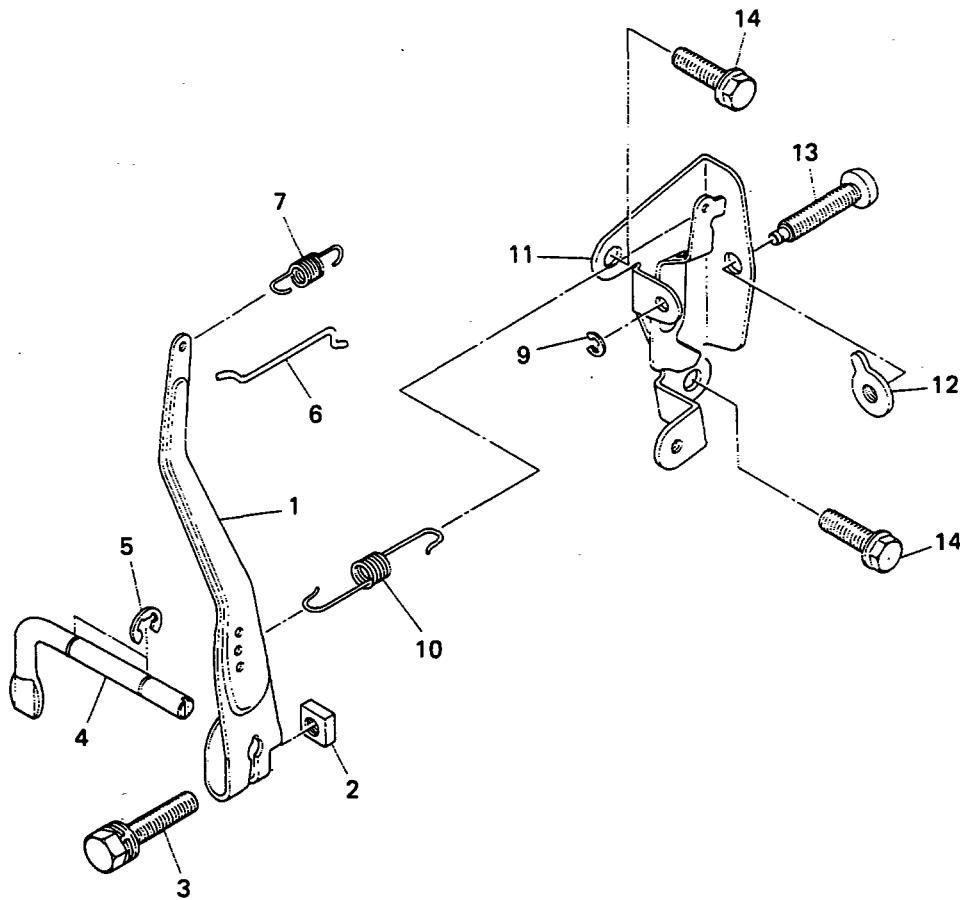

Ref No.	Description	Part Number	Q'ty	Interchangeability		Ref No.	Description	Part Number	Q'ty	Interchangeability	
				Execution	Execution					Execution	Execution
1	GOVERNOR LEVER, complete	230-42301-01	1								
2	NUT	018-60600-20	1								
3	BOLT and WASHER ASSEMBLY	001-14062-50	1								
4	GOVERNOR SHAFT	230-42201-03	1								
5	CLIP	003-13050-00	2								
6	GOVERNOR ROD	230-42701-01	1								
7	ROD SPRING	230-42801-01	1								
9	CLIP	056-50300-10	1								
10	GOVERNOR SPRING	230-42503-01	1								
11	CONTROL BRACKET ASSEMBLY	230-46003-00	1								
12	ADJUSTING NUT, complete	230-49002-01	1								
13	ADJUSTING SCREW, complete	230-49001-01	1								
14	FLANGE BOLT	011-00600-20	2								

When ordering parts; Always give the Model, Specification and Serial Number of Generator.

Fig. 8 MUFFLER and FRONT HOUSING

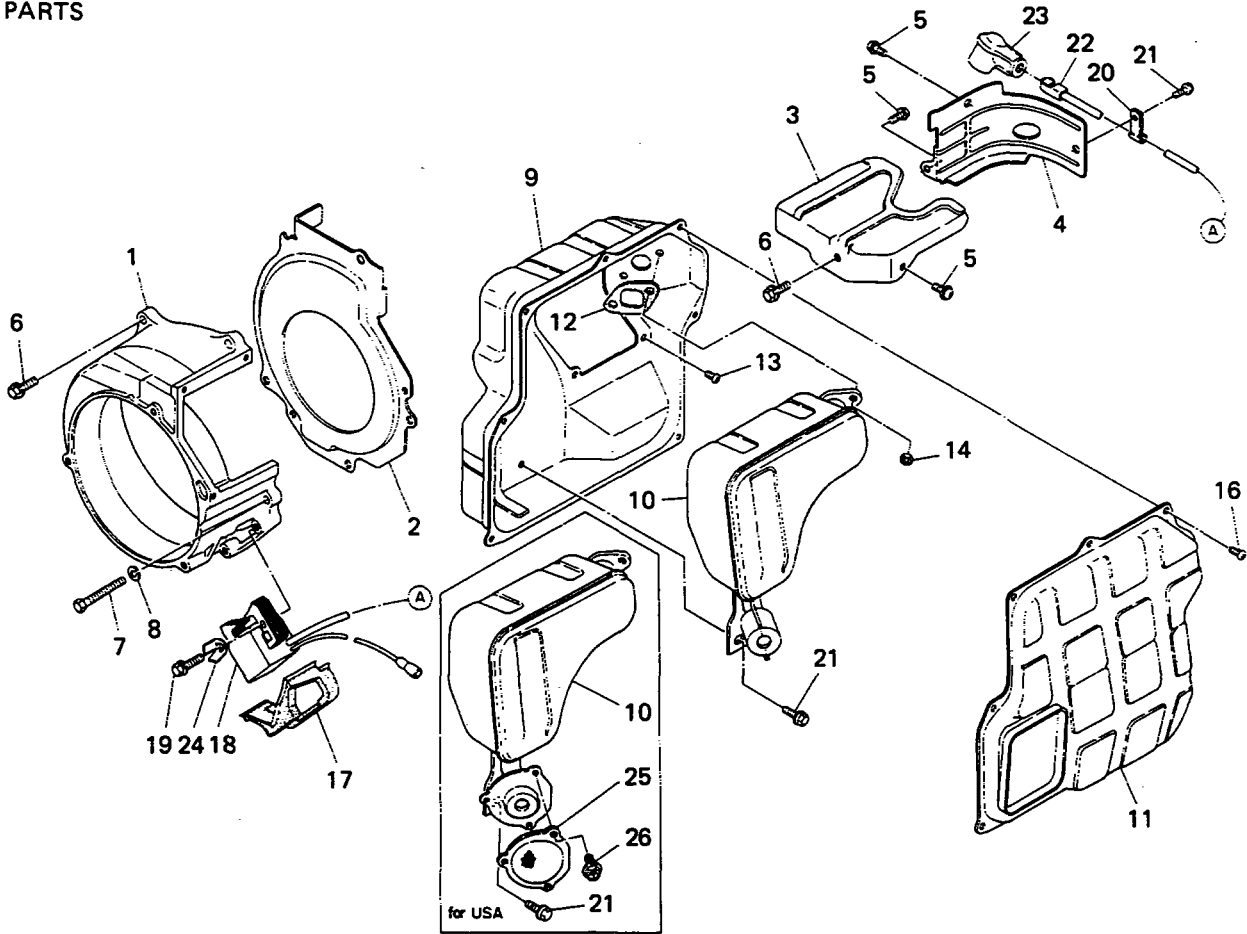

Interchangeability

Interchangeability

Ref No.	Description	Part Number	Q'ty	Execution	Ref No.	Description	Part Number	Q'ty	Execution
1	FRONT HOUSING	230-56002-03	1		19	BOLT and WASHER ASSEMBLY	001-17062-50	2	
2	CENTER BAFFLE	230-53002-03	1		20	CLAMP	214-79002-01	1	
3	HEAD COVER UNIT	230-52801-52	1		21	FLANGE BOLT	011-00600-20	2	
4	CYLINDER BAFFLE	230-52901-43	1		22	SPARK PLUG CAP	065-50001-00	1	
5	SCREW and WASHER ASSEMBLY	004-35051-00	3		23	SPARK PLUG CAP	230-75101-13	1	
6	BOLT and WASHER ASSEMBLY	001-13062-50	4		24	CLAMP	230-75701-03	2	
7	BOLT	001-66065-50	1		25	SPARK ARRESTER, complete For U.S.A.	230-36501-11	1	
8	SPRING WASHER	003-20060-00	1		26	TAPPING SCREW For U.S.A.	015-20500-20	3	
9	MUFFLER COVER 1, complete	230-34213-03	1						
10	MUFFLER, complete	230-30502-01	1						
10	MUFFLER, complete For U.S.A.	230-30602-01	1						
11	MUFFLER COVER 2, complete	230-34214 03	1						
12	GASKET, complete, exhaust	230-35201-01	1						
13	SCREW	004-31050-80	4						
14	NUT	002-19060-00	2						
16	TAPPING SCREW	015-20500-10	7						
17	GROMMET	230-75501-23	1						
18	IGNITION COIL, complete	230-70301-11	1						

When ordering parts; Always give the Model, Specification and Serial Number of Generator.

Fig. 9 CARBURETOR and AIR CLEANER

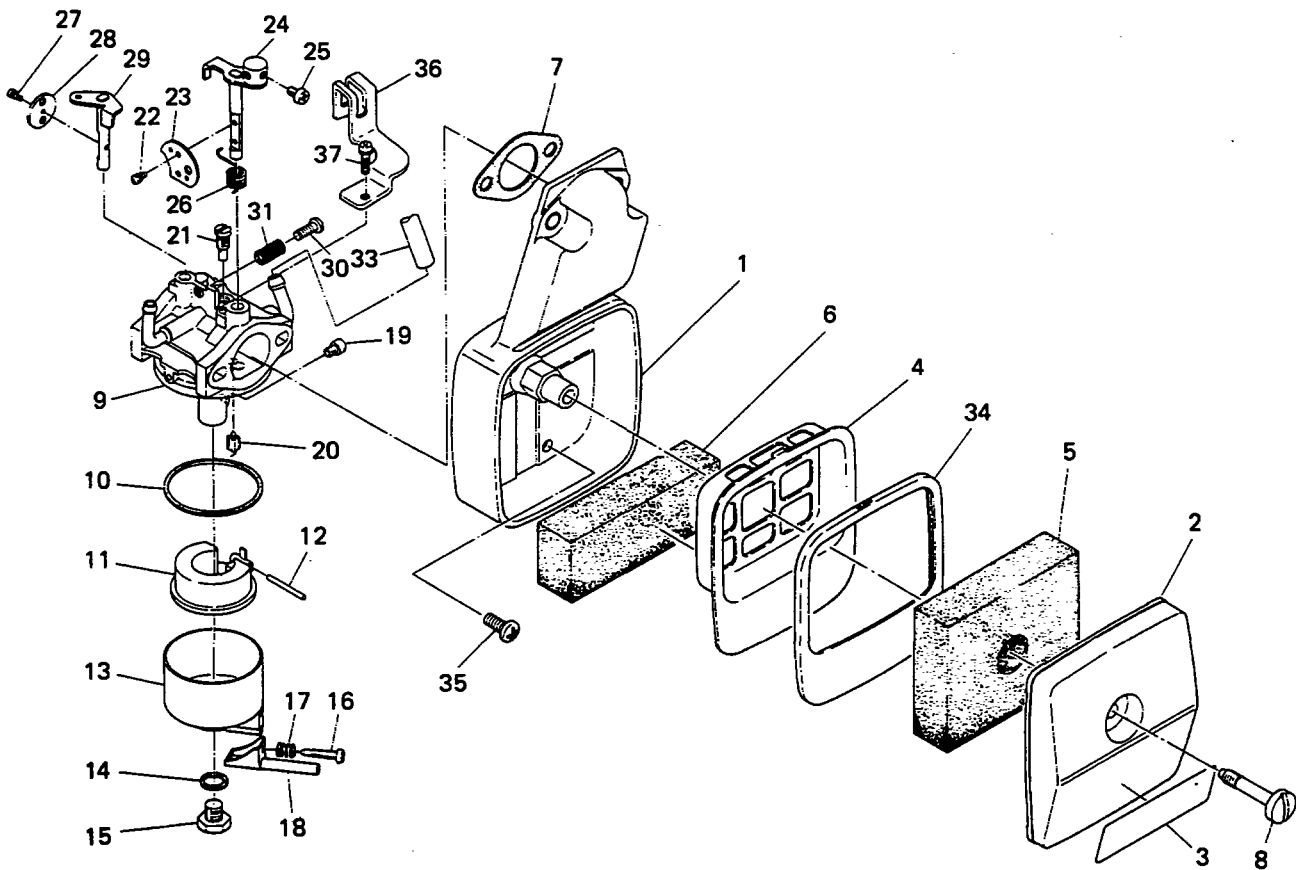

Ref No.	Description	Part Number	Q'ty	Execution	Interchangeability				
					Ref No.	Description	Part Number	Q'ty	Execution
1	CLEANER CASE UNIT	230-35502-22	1		21	PILOT JET (#45)	209-62306-08	1	
2	CLEANER COVER	230-35501-23	1		22	SCREW	226-62351-08	2	
3	LABEL, air cleaner	073-20032-30	1		23	CHOKE VALVE	230-62526-08	1	
3	LABEL, air cleaner For France	073-20032-70	1		24	CHOKE LEVER ASSEMBLY	230-62521-18	1	
4	RETAINER, element	230-36101-23	1		25	CROSS SCREW	209-62354-08	1	
5	ELEMENT, air cleaner	230-36102-03	1		26	RETURN SPRING	230-62447-08	1	
6	ELEMENT 2, air cleaner	230-36103-13	1		27	SCREW	226-62351-08	1	
7	GASKET, air cleaner	230-36003-03	1		28	THROTTLE VALVE (#160)	230-62536-08	1	
8	BOLT, cleaner	230-36201-03	1		29	SHAFT ASSEMBLY, throttle	230-62530-08	1	
*9	CARBURETOR ASSEMBLY Includes items 9 thru 31, 36 and 37	230-62402-00	1		30	SCREW	106-62393-08	1	
10	PACKING, float chamber	230-62540-08	1		31	SPRING	206-62446-08	1	
11	FLOAT ASSEMBLY	230-62506-08	1		33	RUBBER PIPE (5φx8φx320mm)	085-10500-00	1	
12	FLOAT PIN	214-62515-08	1		34	GROMMET, air cleaner	230-36301-03	1	
13	BODY, float chamber	230-62554-08	1		35	SCREW	004-31050-80	1	
14	PACKING	207-62345-08	1		36	BRACKET	230-62572-08	1	
15	BOLT	230-62453-08	1		37	SCREW and WASHER ASSEMBLY	109-62366-08	1	
16	SCREW	224-62450-08	1						
17	SPRING	230-62446-08	1						
18	CAP	230-62561-08	1						
19	MAIN JET (#53.8)	230-62401-08	1						
20	NEEDLE VALVE ASSEMBLY	226-62500-08	1						

When ordering parts; Always give the Model, Specification and Serial Number of Generator.

Fig. 10 RECOIL STARTER

ENGINE PARTS

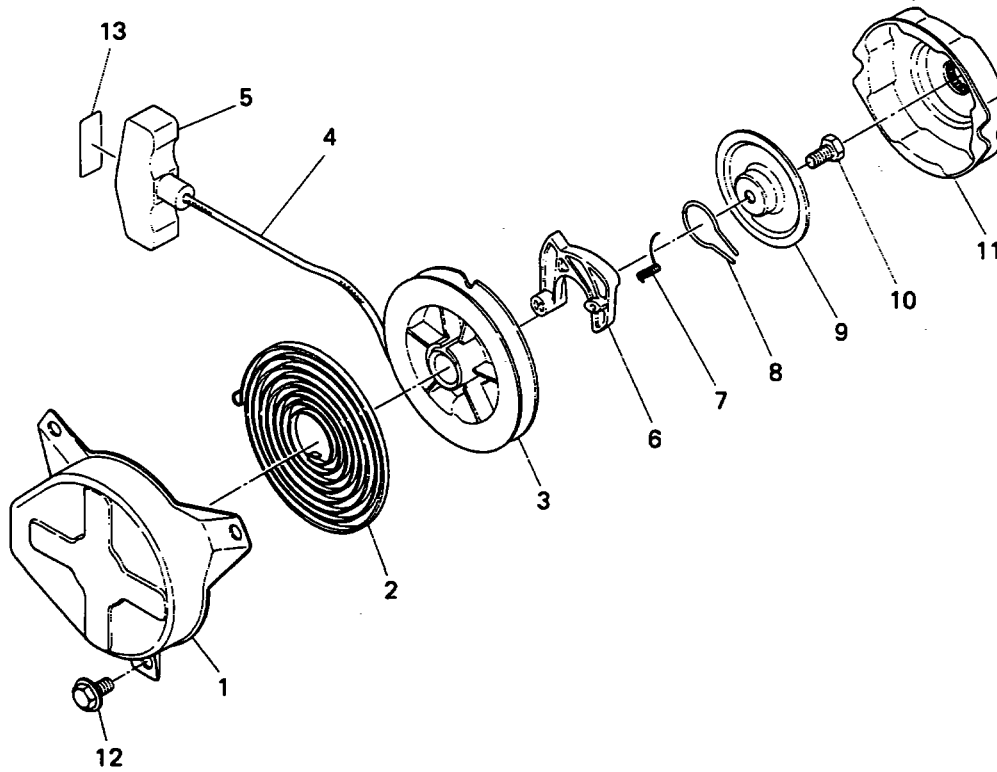

Ref No.	Description	Part Number	Q'ty	Interchangeability		Ref No.	Description	Part Number	Q'ty	Interchangeability	
				Execution	Ref No.					Execution	Ref No.
*1	RECOIL STARTER ASSEMBLY Includes items 2 thru 11	230-50302-00	1								
2	SPIRAL SPRING	230-50116-08	1								
3	REEL	230-50120-08	1								
*4	ROPE ASSEMBLY Includes item 5	230-50106-08	1								
6	RATCHET	230-50128-08	1								
7	RETURN SPRING	230-50135-08	1								
8	FRICTION SPRING	230-50131-08	1								
9	FRICTION PLATE	230-05140-08	1								
10	HEXAGON BOLT	230-50150-08	1								
11	STARTING PULLEY	230-50149-08	1								
12	FLANGE BOLT	011-00600-20	3								
13	LABEL, start For France	073-20025-70	1								

When ordering parts; Always give the Model, Specification and Serial Number of Generator.





Robin America, Inc.

940 Lively Blvd. • Wood Dale, IL 60191 • Phone: 630-350-8200 • Fax: 630-350-8212
e-mail: sales@robinamerica.com • www.robinamerica.com

PRINTED IN THE USA

Robin America, Inc.