



OWNERS MANUAL

MODELS: PM401211
AND PM400911

200-2341 - Revision C

Stationary Standby Electric Generator - 11,200 WATTS - MODEL PM401211
Stationary Standby Electric Generator - 9,700 WATTS - MODEL PM400911

IMPORTANT SAFETY INSTRUCTIONS – Please make certain that persons who are to install, operate and maintain this equipment thoroughly read and understand these instructions prior to operation. **SAVE THESE INSTRUCTIONS** – This manual contains important instructions that should be followed during installation and maintenance of the generator and battery.

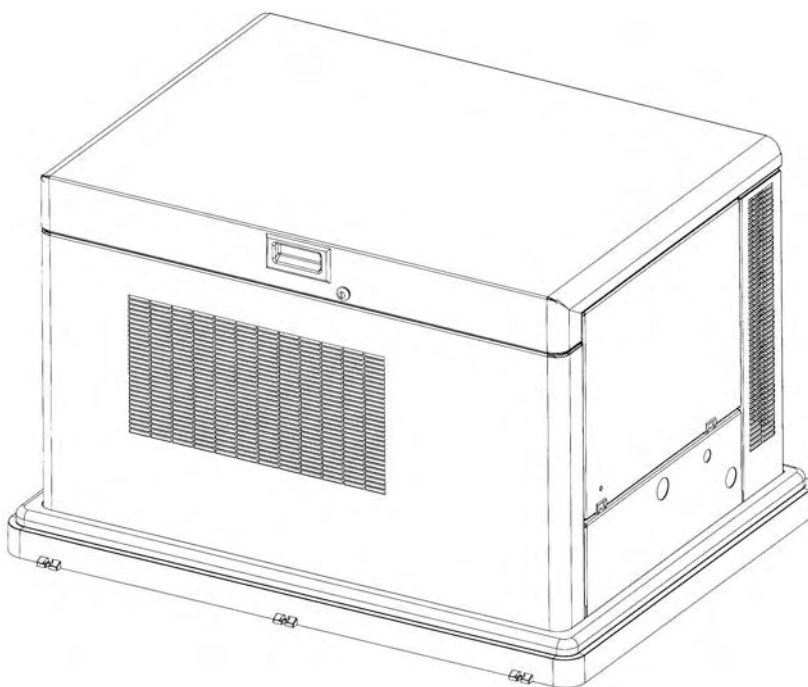

WARNING: Read and understand all safety precautions in this manual and other manuals included with this product before installing, operating and maintaining this equipment. Failure to comply with instructions in this manual could result in personal injury, property damage, and/or voiding of your warranty. Coleman Powermate **WILL NOT** be liable for any damage because of failure to follow these instructions.

Record the model and serial numbers of your generator below:

Model Number

Serial Number

Date Purchased



TABLE OF CONTENTS

Table of Contents	2
General Safety Instructions	3-4
Installation	5-18
Introduction	5
Unpacking Instructions	5
Installation Planning	5
Generator location	6
Automatic Transfer Switch	7
Generator installation	8
Generator placement and anchoring	8
Installation Drawings	9
Electrical hookup	10
Main line output power	10
GFCI Circuit supply	11
Generator start signal	11
12KW Wiring Diagram (CP200)	12
Fuel specifications and consumption requirements	13
Fuel hookup	14
Natural gas (NG)	14
Propane vapor (LPG)	15
Battery requirements	16
Battery placement and connection	16-17
Lubrication	17
First time startup	18
Specifications	19-20
Generator	19
Engine	19
Alternator	20
Electrical	20
Fuel	20
Generator feature identification	21
Generator operation	22-24
Control panel features	22
Starting the generator	23
Cyclic crank	23
Run state	23
Shutdown	23
Status indicators	24
Faults	24
Maintenance	25-33
Maintenance schedule	25-26
Engine oil level check	26
Engine oil and oil filter change	27
Engine oil cooler inspection and cleaning	27
Engine air filter change	28
Battery maintenance	28-29
Spark plug check	30
Spark plug arrestor cleaning	31
Enclosure and site maintenance	32
Governor speed adjustment	32
Valve clearance check and adjustment	33
Fuel system inspection	33
Generator diode replacement	33
Generator varistor replacement	33
Troubleshooting	34-35
Parts drawings and lists	36-43
Warranty information	46
Service contact information	47

GENERAL SAFETY GUIDELINES

The following information relates to protecting YOUR SAFETY and PREVENTING EQUIPMENT PROBLEMS. To help you recognize this information, we use the following symbols. Please read the manual and pay attention to these sections. Also read and follow all safety labels on the engine/generator set. If labels are damaged or unreadable, contact product service for replacements.



This is the safety alert symbol. It is used to alert you to potential personal injury hazards. Obey all safety messages that follow this symbol to avoid possible injury or death.



Ground Location.

⚠ DANGER: – A POTENTIAL HAZARD THAT WILL CAUSE SERIOUS INJURY OR LOSS OF LIFE.

⚠ WARNING: – A POTENTIAL HAZARD THAT COULD CAUSE SERIOUS INJURY OR LOSS OF LIFE.

⚠ CAUTION: – A POTENTIAL HAZARD THAT MAY CAUSE MODERATE INJURY OR DAMAGE TO EQUIPMENT.

NOTE: Improper installation can damage your electrical system and cause property damage, serious personal injury or death. Installation **MUST** be performed by a licensed electrician and licensed plumber, or gas technician. Installation **MUST** comply with all applicable building and electrical codes. Some areas may require building permits and/or detailed sight inspections prior to approving the unit for operation.





NOTE: The important safety instructions appearing in this manual are not meant to cover all possible conditions and situations that may occur. It must be understood that common sense, caution, and care are factors which are not built into a generator, but are supplied by the person(s) installing, maintaining, and operating it.

⚠ WARNING:





- ⚠** Do not attempt to install the generator yourself. Extremely high and dangerous electrical voltages are present in utility power source lines and in generator load leads when the unit is running. Therefore, be sure to turn OFF all power voltage supplies at their source before attempting to complete electrical connections. Only qualified installation contractors or electrician's who are familiar with applicable codes, standards, regulations and procedures should install the system. Improper or unauthorized installation, operation, or service of this equipment is extremely hazardous and may result in serious personal injury or death.
- ⚠** It is NOT intended that the information in this manual be used by any unqualified persons for the purpose of installing a standby electric power system. This equipment must be installed, inspected, tested and adjusted only by qualified personnel. These people must be familiar with the equipment and installation requirements.
- ⚠** The installation of this unit must comply with the regulations of the United States National Electric Code (NEC) as well as state and local codes and Occupational Safety and Health Administration (OSHA) established in the United States.
- ⚠** This equipment, when installed as part of a standby electric power system, must be installed in conjunction with an approved transfer switch. The transfer switch serves to prevent both generator and utility power from being connected to the load circuits at the same time. A properly connected transfer switch helps to prevent backfeed of generator power into commercial lines while the standby generator is operating.
- ⚠** This generator supplies extremely high and dangerous power voltages. Any contact with high voltage electrically "hot" components will result in extremely hazardous, and possibly LETHAL, electrical shock. Use care to avoid contact with live terminals, bare connectors, bare wires, etc. Disconnect all power before performing maintenance or service.
- ⚠** Generator exhaust air contains carbon monoxide, a deadly odorless, colorless and tasteless gas. Breathing carbon monoxide causes severe nausea, fainting or death. Install the generator set outdoors only. Do not use exhaust air to heat a room. Do not allow exhaust air to enter a building through windows, doors, air intakes or other means. Avoid breathing exhaust air while installing, operating or servicing generator set. The engine exhaust from this product contains chemicals known to the State of California to cause cancer, birth defects, or other reproductive harm.
- ⚠** Short circuits can cause bodily injury and/or equipment damage. Do not contact electrical connections with tools or jewelry, make sure clothing and shoes are dry and stand on a dry wooden platform while adjustments are made. Remove wristwatch, rings, and jewelry that can cause short circuits.

GENERAL SAFETY GUIDELINES (Continued)

WARNING:

-  The National Electrical Code (NEC) requires the frame and external electrically conductive parts of the generator to be connected to an approved earth ground.
-  Keep a fire extinguisher near the generator at all times. Extinguishers rated "ABC" by the National Fire Protection Association are appropriate for use on the standby electric system. Keep the extinguisher properly charged and be familiar with its use. If you have any question pertaining to fire extinguishers, consult your local fire department.
-  Generator/engine noise can cause hearing loss. Never operate the generator set without a muffler or with a faulty exhaust system. Always wear hearing protection when near or operating the generator.
-  **DO NOT** permit anyone to operate the standby electric system without proper instruction.

CAUTION:

-  Units with broken or missing parts, without protective housing or covers should never be operated. Contact your service center for replacement parts.
-  Inspect the generator regularly, and contact your nearest Authorized Dealer for parts needing repair or replacement.
-  Never use the generator or any of its parts as a step. Stepping on the unit can stress and break parts, and may result in dangerous operating conditions from leaking exhaust gases, fuel leakage, oil leakage, etc.
-  Thoroughly read the OPERATORS MANUAL before operating the generator. Safe operation and top performance can be obtained only when equipment is operated and maintained properly.
-  Ensure that enclosure doors are closed and locked at all times other than during service.

INTRODUCTION

The stationary standby electric generator is manufactured for our customers to supply reliable backup power. The generator is a compact unit, designed to supply the power for your needs when utility power fails.

The standby generator runs on Liquid Propane Vapor or Natural Gas allowing flexibility for getting the power you need. Fuel lines should be installed by a licensed plumber or licensed gas technician.

⚠️ WARNING ⚠️

RISK OF ELECTROCUTION AND/OR INJURY



- **The installation of this equipment must be done by licensed electricians, contractors, gas technicians, and plumbers. Installation must be completed in conformance with NEC and local electrical and building codes. Some areas may require building permits and/or detailed sight inspections prior to approving the unit for operation.**

•About the Owners Manual

Understanding the operation of the generator is important when using or maintaining your system. If there are any questions about the information supplied in this Owner's Manual, call our customer service helpline number shown on the cover of the manual.

•About Operation or Maintenance

All required safety checks that need to be performed are the responsibility of the operators. Listed within the Owners Manual are safety precautions to be followed to prevent personal injuries to persons around the unit and to prevent property damage.

UNPACKING INSTRUCTIONS

Immediately inspect the generator carefully for freight loss or damage upon arrival. If loss or damage is noted at the time of delivery, require the person making the delivery to note the loss or damage on the freight bill, or affix his signature under the consignor's memo of the loss or damage. Contact the carrier for claim procedures.

When loss or damage is noted after delivery, segregate the damaged material, and contact the carrier for claim procedures. Be sure to retain the packaging material for carrier inspection.

"Concealed Damage" is understood to mean damage to the contents of a package which is not evident at the time of delivery by the carrier, but which is discovered later. The carrier or carriers are responsible for merchandise lost or damaged in transit. The title to goods rests with the consignee when generators are shipped F.O.B. factory, and only the consignee can legally file a claim.

After inspecting the generator, engine and enclosure for physical damage, finish reading the Operating and Maintenance Instructions. These manuals contain important safety information.

⚠️ WARNING ⚠️

RISK OF INJURY AND BEING CRUSHED



- **HEAVY EQUIPMENT. Unbalanced weight. Improper lifting can cause severe injury or death and equipment damage.**
- **When lifting the generator or using hoisting equipment, be careful not to touch overhead power lines. Proper tools and equipment and qualified personnel should be used in all phases of handling and unpacking.**

INSTALLATION PLANNING

⚠️ DANGER ⚠️



- **Improper installation can damage your electrical system and cause property damage, serious personal injury or death. Installation MUST be performed by a licensed electrician and plumber, or gas technician and installation MUST comply with all applicable building and electrical codes. Some areas may require building permits and/or detailed sight inspections prior to approving the unit for operation.**

Taking a few moments to pre-plan before beginning installation of the generator can provide significant savings in materials and labor and lower future maintenance. Some items to consider in planning generator installation are safe generator operation, use of an Automatic Transfer Switch, load requirements, generator location, fuel supply, environmental conditions and applicable local, regional or national codes. Some areas may require building permits and/or detailed site inspections prior to approving the unit for use. Check with local authorities before starting installation.

Installation of a standby engine/generator system is complex and should not be considered a Do-It-Yourself project. Safe installation requires the skill and knowledge of licensed electricians, plumbers, and professional generator contractors. Contact an authorized dealer for assistance with installation planning and referral to properly qualified, licensed installing contractors.

GENERATOR LOCATION

Proper location of the generator set is important to insure safe and reliable operation and can aid in the installation of the generator. When selecting a site for the generator, first ensure that the pad is outdoors in a well ventilated area to allow for proper cooling and proper removal of deadly exhaust fumes created during operation. Consider the direction of the engine exhaust exiting the cabinet and orient the generator on the site with the exhaust away from any windows, doors, ventilation intakes or other openings that can allow engine exhaust fumes to collect in a confined area. In addition, take into account any prevailing winds or other air currents that could carry engine exhaust fumes in unintended directions.

For minimum installation costs, plan to locate the generator outside at a position adjacent to the electrical service distribution panel and close to the intended fuel supply.

To assure adequate cooling air and access for maintenance, plan to locate the generator so that a minimum of three (3) feet of clear, unobstructed space is available on all sides of the cabinet, including above the lid. If landscaping is used to mask the generator from view or further control sound, leave enough room so that the mature plants still allow three feet of clear space around all sides. If necessary, place a screen style fence around the site to prevent grass, leaves or other combustible debris from gathering around the generator, creating a fire risk.

DANGER



- **Generator exhaust air contains carbon monoxide, a deadly odorless, colorless and tasteless gas. Breathing carbon monoxide causes severe nausea, fainting or death. Install the generator outdoors only. Do not use exhaust air to heat a room. Do not allow exhaust air to enter a building through windows, doors, air intakes or other means. Avoid breathing exhaust air while installing, operating or servicing the generator. The engine exhaust from this product contains chemicals known to the State of California to cause cancer, birth defects, or other reproductive harm.**
- **Considerations for proper rooftop placement and weight distribution must be designed by a licensed engineer or architect.**

WARNING



- **For fire safety, the generator must be installed and maintained properly. Installation always must comply with applicable codes, standards, laws and regulations. Adhere strictly to local, state and national electrical and building codes. Comply with regulations established by the Occupational Safety and Health Administration (OSHA) and National Electrical Code (NEC).**
- **This generator is designed to be installed outside only. Never install this unit inside any room, enclosure, or basement. The generator needs adequate cooling and ventilation for continued proper and safe operation.**
- **The exhaust from this product is extremely hot and remains hot after shutdown. High grass, weeds, brush, leaves or other combustible materials, must remain clear of the exhaust. Such materials may ignite and burn from the heat of the exhaust system.**

CAUTION

- **Covering or restricting the air passages on the generator will cause the unit to overheat and may create a fire hazard. Do not allow snow or leaves to cover enclosure openings.**
- **Leave a three foot open area around all sides of the unit. Do not plant trees or plants which may grow within three feet of the unit.**
- **Unit should be located to prevent combustible material from accumulating against the generator set.**
- **The generator MUST be installed outdoors.**

AUTOMATIC TRANSFER SWITCH

When connecting the generator to a building electrical distribution system, use of a transfer switch is recommended to isolate the normal utility source from the generator supply. By preventing backfeed of the generator power into the utility lines during a utility power outage, the switch provides a level of safety for electrical line workers. An automatic transfer switch listed to Underwriters Laboratories Standard 1008 performs this function while also supplying a method to automatically start and stop the generator set and transfer power to the building electrical system from an appropriate source.

When planning for a transfer switch/generator installation, it is necessary to know the method of interconnection to the building system. As illustrated, it is recommended to connect the generator to power only circuits that are necessary during a power outage. When following this method, the transfer switch feeds an electrical sub-panel containing only the necessary circuits (see figure 1). Another option is to connect the transfer switch directly to the entire building electrical distribution system. In this case, all circuits or loads must be controlled to avoid overloading and possibly damaging the generator set (see figure 2).

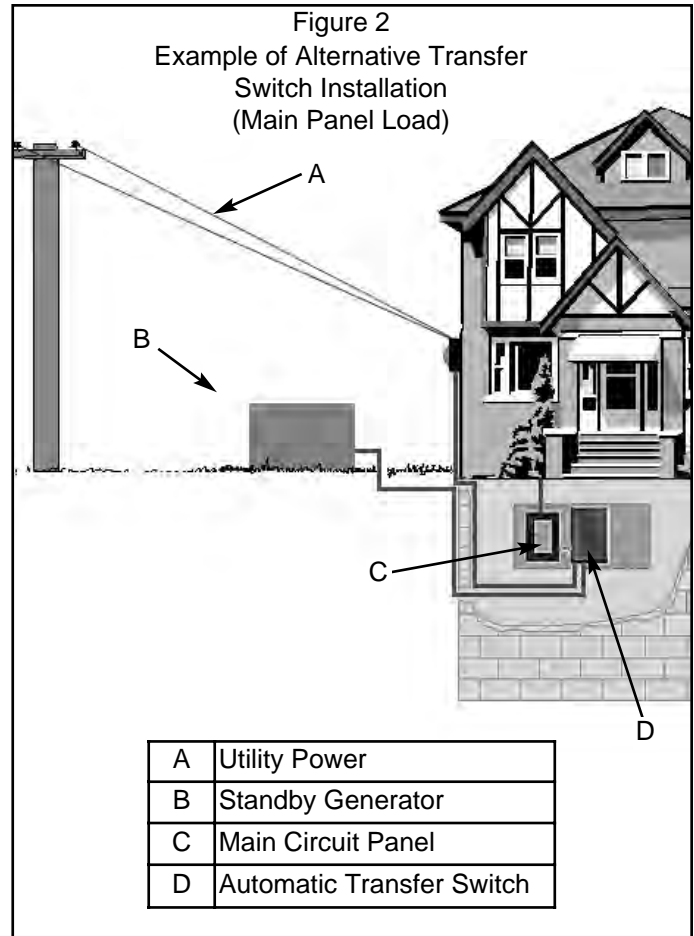
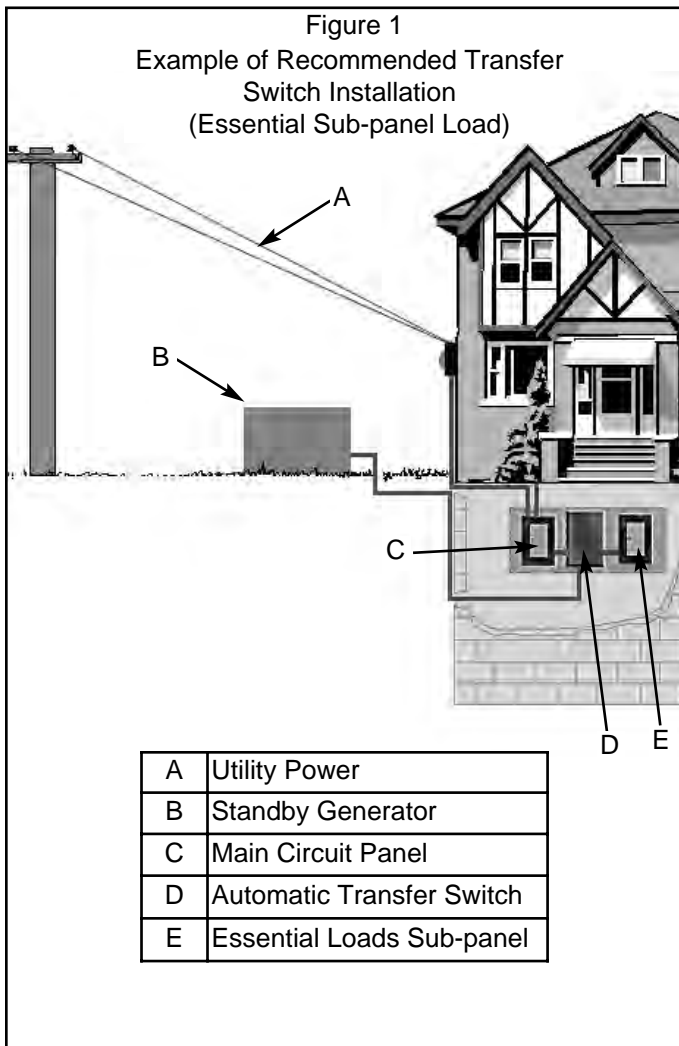

Switch selection is based on factors such as the size of the building distribution system, available generator power and required generator control system. Due to the complex nature of electrical distribution systems, the sizing, selection and installation of a switch is best handled by a licensed electrician or qualified standby generator dealer. Any switch installation must be performed by a licensed electrician to the instructions of the switch manufacturer and any applicable local, regional or national codes.

⚠ WARNING ⚠

- **Hazardous "backfeed" voltage can cause severe injury or death. Install a transfer switch in standby power installations to prevent connection of standby to other sources of power. Electrical backfeed into a utility electrical system can cause serious injury or death to utility personnel working on transmission lines.**
- **Do not try MANUAL operation of the transfer switch until all power supplied to the switch has been positively turned OFF. Failure to remove power from all sources may result in extremely dangerous and possibly lethal electrical shock or arcing.**

GENERATOR INSTALLATION

Once installation planning is complete and all necessary local permits are granted, installation of the generator may begin. Within the following section general recommendations are given for installing the generator. However, installations are affected by local site conditions, regional construction practices, material availability, local or regional codes and/or other variables. Therefore, recommendations included in this manual are provided as a guide only and are not meant to serve as detailed installation plans. All decisions regarding installation and materials are at the discretion of the licensed electricians and licensed plumbers performing the installation and/or the inspector performing the final inspection as required by local or regional code. Additionally, illustrations provided in this manual are subject to ongoing revisions and shall not be construed as blueprints.

PLACEMENT AND ANCHORING

The generator is supplied with an integral molded plastic base for use as an installation pad. Use of this base is intended to minimize installation cost by eliminating the need for a poured concrete pad.

A pad of crushed gravel a minimum of three inches thick is recommended as a base to set the generator on. Compact the gravel and ensure that the pad is level in all directions, making sure that the overall pad height is greater than the surrounding grade with a slope to carry water away from all sides of the pad. Pad dimensions at least six inches larger than the base size in all directions are recommended.

It is possible to use a standard concrete pad if desired. When using this method, a lightly steel reinforced pad a minimum of 2 inches thick, poured to local codes is recommended. Ensure the pad extends past the generator pallet and is high enough to promote drainage of water away from the generator.

After preparing the base pad, position the generator directly on the pad (A), complete with the wooden skids supplied for shipping. Remove the lag bolts (B) fastening the wood to the pallet from all six positions. Using a pry bar with a block of wood as a pivot, carefully lift one end of the pallet and remove the wooden skids from both that end and the center of the pallet (C). Lower the pallet to the pad, then pry the other end up and remove the skid from that end (D). Check the generator with a level in all directions, placing material under the base as required.

Although the weight of the generator is adequate to prevent movement during normal operation, anchoring of the generator is recommended. To anchor the generator on a gravel pad, drive a minimum of four (4) spikes through the anchoring tabs located on the outside corners of the pallet. If a concrete pad is used, anchor the pallet at the same points using appropriate concrete fasteners.

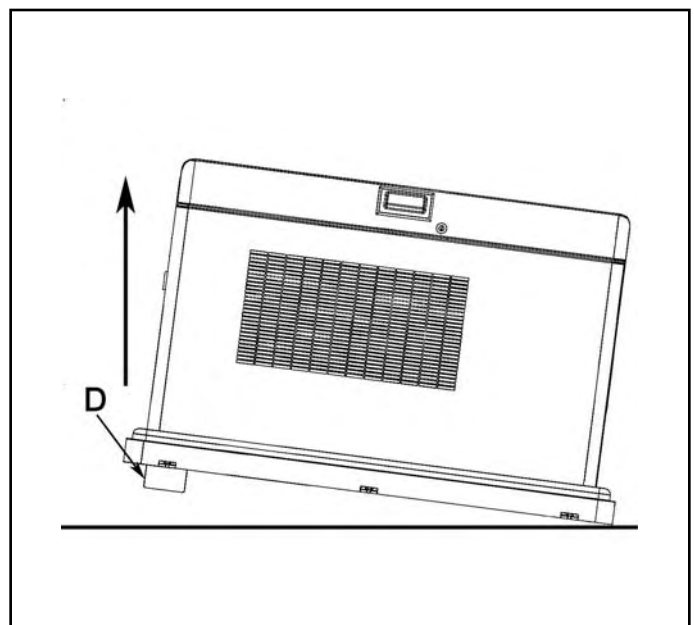
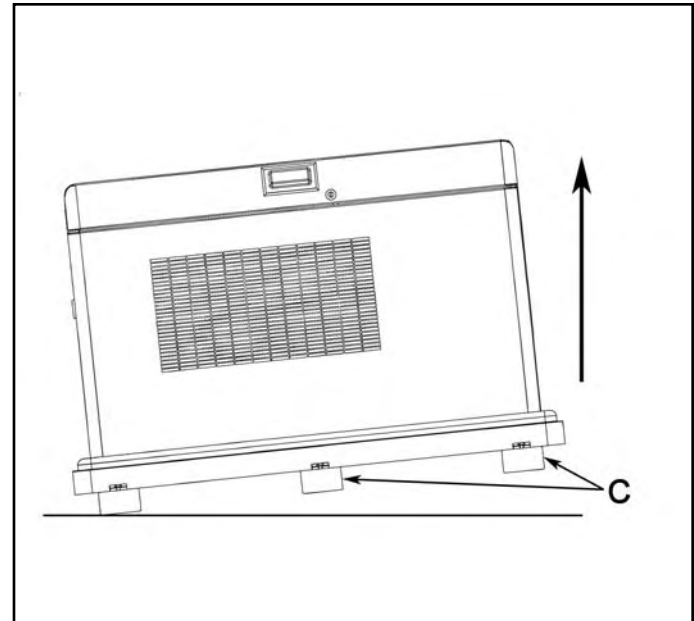
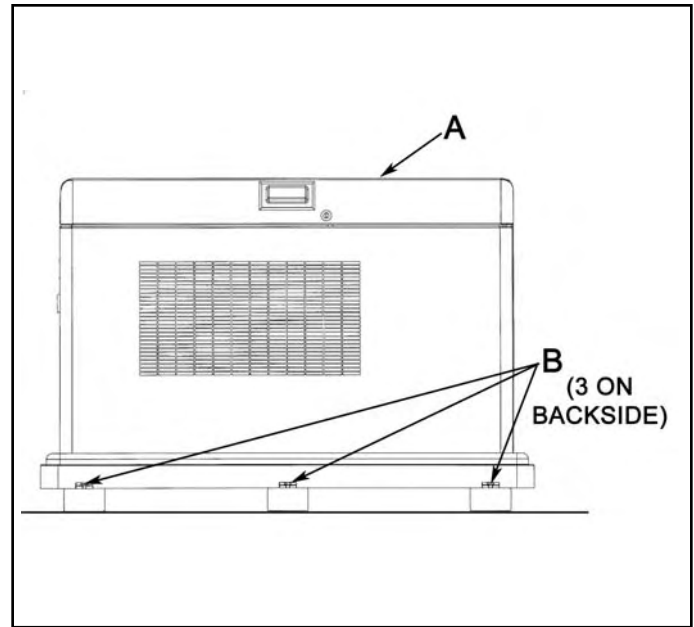

INSTALLATION DRAWINGS

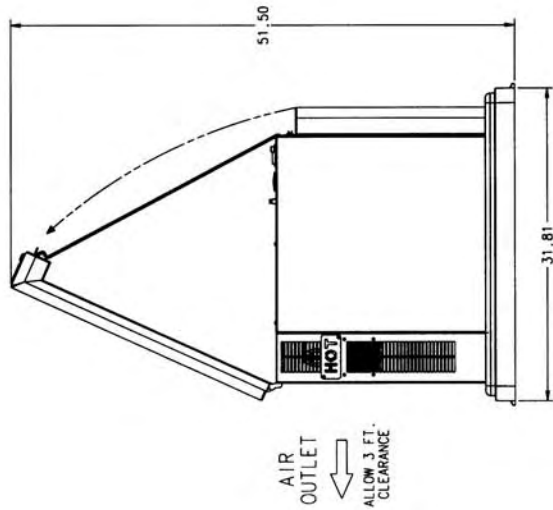
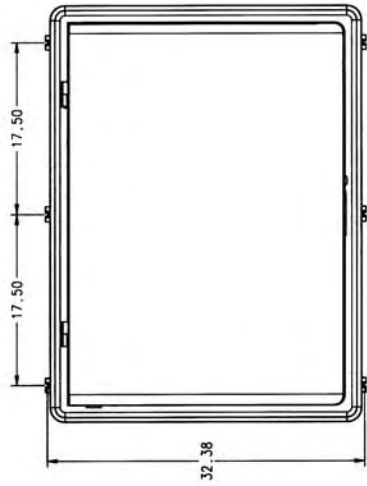

AIR OUTLET
 ↓
 ALLOW 3 FT. CLEARANCE

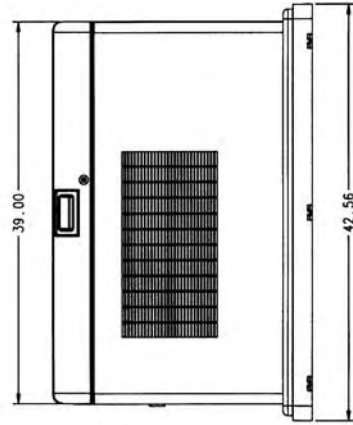

AIR OUTLET
 ↓
 ALLOW 3 FT. CLEARANCE

AIR OUTLET
 ↑
 ALLOW 3 FT. CLEARANCE

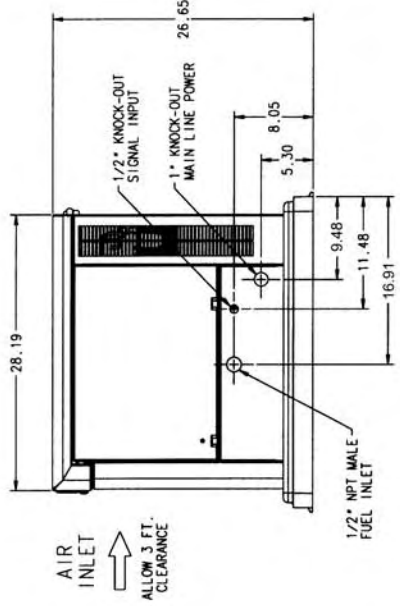

AIR INLET
 ↑
 ALLOW 3 FT. CLEARANCE

ELECTRICAL HOOKUP

Once the generator is anchored in its final position, it is ready for electrical connections. The generator is supplied with two terminal blocks for connection of three distinct electrical circuits; main line output power, GFCI power input and remote start signal. Main line output power is the electrical output of the generator, GFCI input powers the battery charger and optional block heater devices and the remote start signal is the interface with an Automatic Transfer Switch that allows the generator to operate automatically upon a utility power outage.



- **Improper installation can damage your electrical system and cause property damage, serious personal injury or death. Installation MUST be performed by a licensed electrician and plumber, or gas technician and installation MUST comply with all applicable building and electrical codes. Some areas may require building permits and/or detailed sight inspections prior to approving the unit for operation.**

To access the wiring connection terminal blocks, open the generator lid (A) and place the lid prop rod (B) into the slot (C) on the underside of the lid. Remove the three screws (D) from the access panel, then open the hinged access panel (E) as shown in Fig A. The access panel is removable by pulling the pins from the panel hinges. Locate the two terminal blocks (F) on the lower right corner of the engine partition panel.

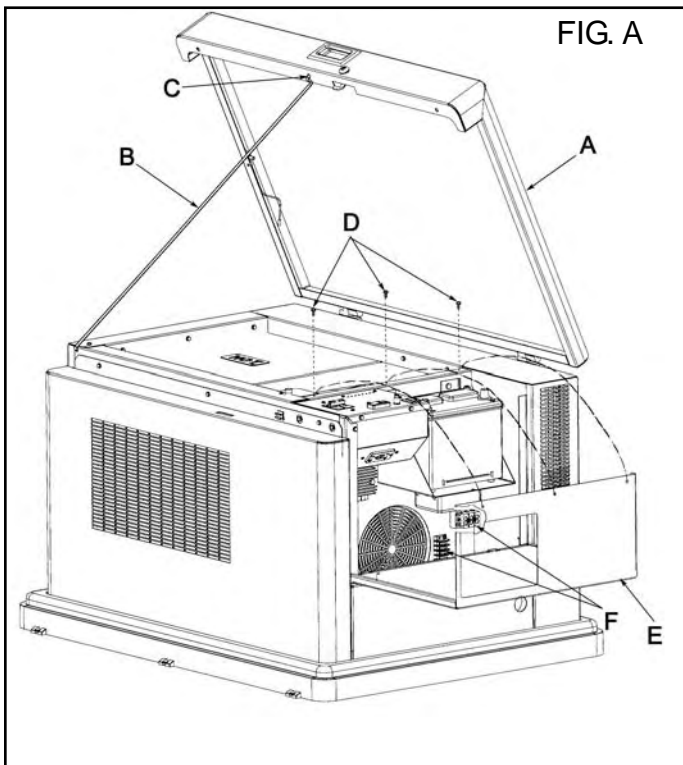

MAIN LINE OUTPUT POWER

The output circuit of the generator is 4-wire, 240V, rated for the amperage as shown on the generator nameplate. Connection to the transfer switch requires two leads, commonly referred to as "hot" leads (L1 & L2), a neutral (N), and ground lead. Positions of these leads are labeled on the main line output terminal block, also shown in Fig. B. **Select proper power output wire sizes according to allowable ampacities given in Table 310-16 of the latest revision of The National Electric Code(NFPA 70).** To connect the wires, strip the insulation back approximately ½" from the end of the wire, insert the stripped end into the terminal block, then torque the terminal block screw to **35 in-lbs (4.0 N-m)**.

FIG. B

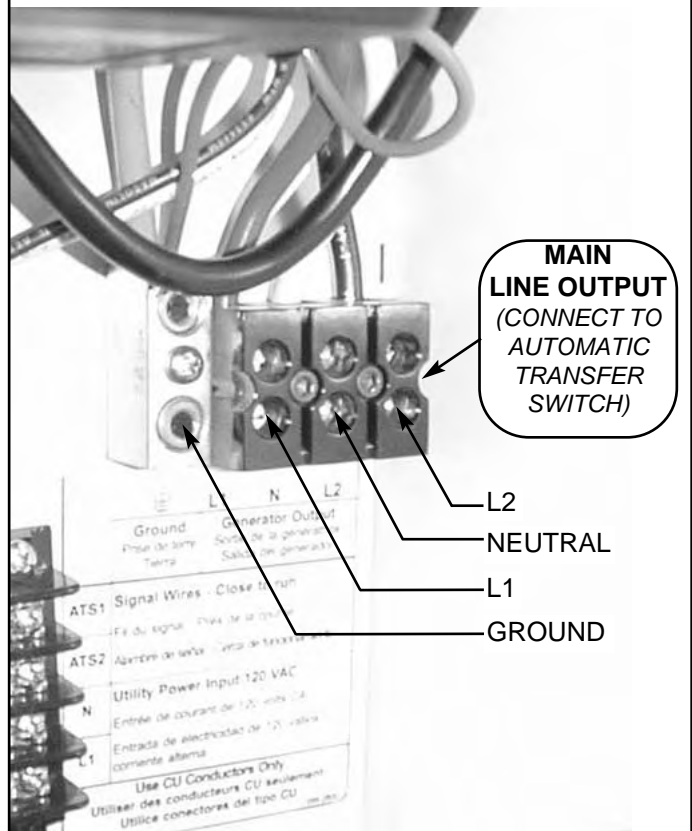

- **Hazardous voltage can cause severe injury or death. Electrocutation is possible whenever electricity is present. Open the main circuit breaker of all power sources before servicing the equipment. Configure the installation to electrically ground the generator set, transfer switch and related equipment and electrical circuits to comply with applicable codes and standards. Never contact electrical leads or appliances when standing in water or on wet ground because these conditions increase the risk of electrocutation.**

GFCI CIRCUIT SUPPLY

A ground fault circuit interrupting (GFCI) receptacle is provided with the generator to power the battery charger for reliable starting. It is also intended to power an optional block heater if that option is desired. Connection of this circuit to a power supply that is only present when normal utility power is supplied is recommended. By connecting the GFCI in this fashion, it is possible to insure that neither the battery charger or block heater are on while the engine is running. Precautions are engineered into the generator to prevent these occurrences but connection of the circuit in this fashion provides an additional fail-safe method of engine and battery protection.

Input to the GFCI circuit is 3-wire, 120V, 15A. Connections include a "hot" lead (L1), neutral (N) and ground lead. Positions of the incoming wire connections are labeled at the auxiliary connection block, shown in Fig.C. **Select proper GFCI supply wire size according to allowable ampacities given in Table 310-16 of the latest revision of The National Electric Code(NFPA 70).** To connect the wires, strip the insulation back approximately ¼" from the end of the wire, insert the stripped end under the screw and washer on the terminal block, then torque the terminal block screw to **20 in-lbs (2.3 N-m).**

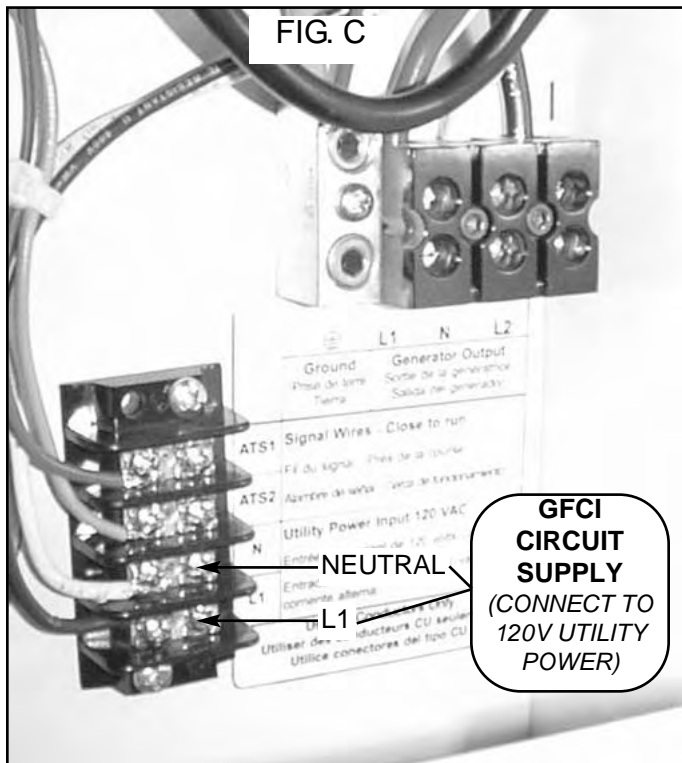

GENERATOR START SIGNAL

When the control panel mode switch is placed in the AUTO position, generator starting and stopping is controlled by the opening or closing of a set of voltage free contacts. Two wires from those contacts are connected to the generator through the auxiliary connection block shown in Fig. D. Use of a twisted pair of stranded copper wire no smaller than AWG 18 gage is recommended. To insure proper operation of the auto start feature, use a transfer switch offering "close-to-run" control contacts. To connect the wires, strip the insulation back approximately ¼" from the end of the wire, insert the stripped end under the screw and washer on the terminal block, then torque the terminal block screw to **20 in-lbs (2.3 N-m).**

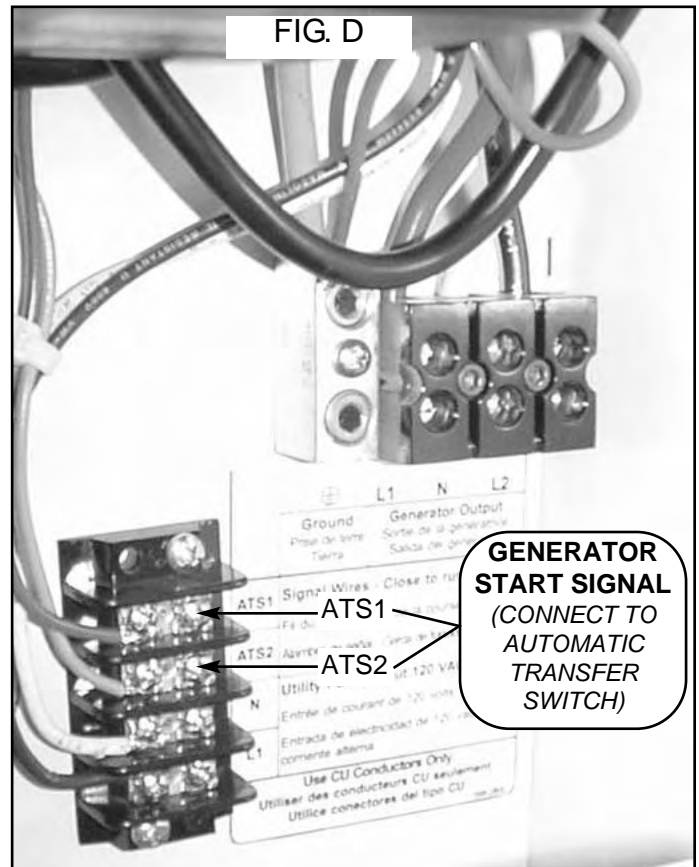

12KW WIRING DIAGRAM (CP200 CONTROLLER)

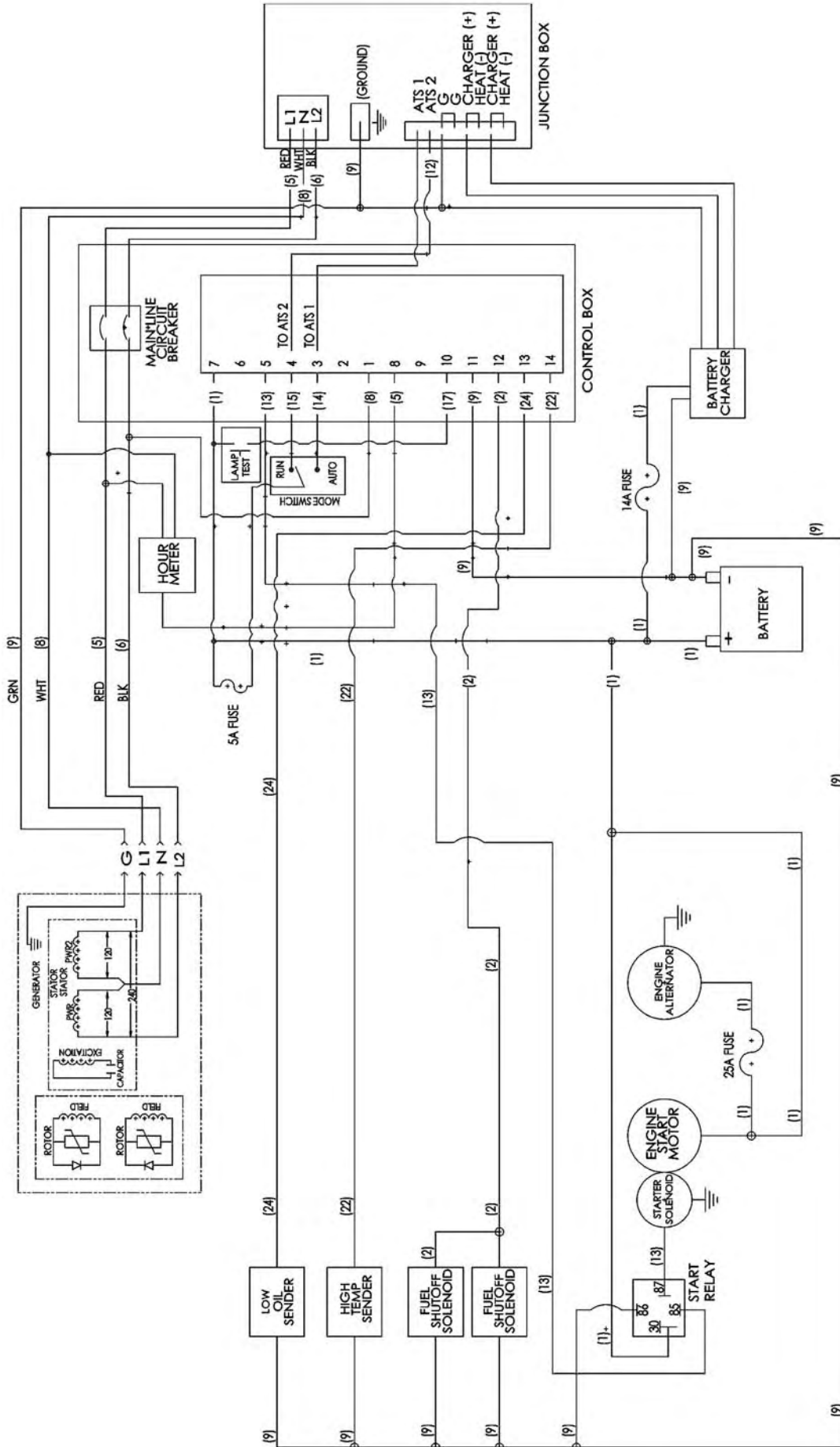

RELAY WIRING INFORMATION	
RELAY PIN	WIRE NUMBER
30	1
85	13
86	9
87	13

WIRE NUMBER LEGEND			
WIRE NO.	WIRE NAME/DESCRIPTION	WIRE NO.	WIRE NAME/DESCRIPTION
1	BATTERY POSITIVE	21	NOT ASSIGNED
2	SWITCHED BATTERY POSITIVE	22	HIGH TEMPERATURE SENDER
3	GENERATOR GROUND	23	LOW OIL SENDER
4	CONTROLLER START SIGNAL	24	NOT ASSIGNED
5	GENERATOR LINE 1	25	NOT ASSIGNED
6	GENERATOR LINE 2	26	NOT ASSIGNED
7	GENERATOR LINE 3	27	NOT ASSIGNED
8	GENERATOR NEUTRAL	28	NOT ASSIGNED
9	BATTERY GROUND	29	NOT ASSIGNED
10	IGNITION SPARK SIGNAL	30	NOT ASSIGNED
11	IGNITION TIMING INPUT	31	NOT ASSIGNED
12	REMOTE START +	32	120V UTILITY HOT
13	STARTER SHIFT SIGNAL	33	120V UTILITY NEUTRAL
14	MODE SWITCH/AUTO	34	CT 1
15	MODE SWITCH/RUN	35	CT 1 COMMON
16	MODE SWITCH/COMMON	36	CT 2
17	LED TEST	37	CT 2 COMMON
18	NOT ASSIGNED	38	CT 3
19	NOT ASSIGNED	39	CT 3 COMMON
20	NOT ASSIGNED	39	CT 3 COMMON

FUEL SPECIFICATIONS AND CONSUMPTION REQUIREMENTS

The engine driving the generator is engineered to provide reliable power on either Liquefied Propane Vapor (LPG) or Natural Gas. For proper operation on these fuels, it is important to deliver gas with adequate energy content, at sufficient pressure and flow rate. This is designed to operate on Liquefied Propane Vapor (LPG) with a minimum energy content of 2500 BTU per cubic foot or Natural Gas with a minimum energy content of 1000 BTU per cubic foot. This generator is designed to operate with a **fuel pressure** at the inlet of the unit between **7 and 11 inches of water column (4-6 ounces)**.

Required fuel flow rates for specific models are given in the table below. To insure correct sizing of the piping supplying fuel to the generator set, provide the flow and pressure requirements of this section to a fuel supplier or licensed plumber during the installation planning stage. If the fuel supplier cannot guarantee delivery of fuel with these properties, the generator may not perform as advertised.

Due to differences in the energy content of fuel used, it is necessary to derate the output of the generator when connected to Natural Gas. Additionally, regional and/or seasonal variations in the makeup of the fuel can further affect output of the engine/generator system. When using Natural Gas fuel with minimum properties as defined, engine output can fall approximately 10% below that of the same set using Propane Vapor.

FUEL CONSUMPTION TABLE

	LP Vapor (ft 3/hr)	LP Vapor (Gal/hr)	Natural Gas (ft 3/hr)
PM401211	81	2.2	186
PM409011	79	2.1	176
All values reflect consumption at 100% rated output.			

Per the National Gas Code (NFPA 54 - ANSI 2223.1), a manual shutoff valve in the fuel supply line to the generator is recommended.

DANGER

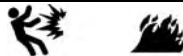

- **All fuel system installations MUST BE done by a licensed plumber or licensed gas technician and must comply with all applicable codes, standards and regulations.**

WARNING



- **Natural gas (NG) is highly explosive.**
- **Natural gas (NG) is lighter than air and collects in high places.**
- **Liquid propane vapor (LPG) is highly explosive.**
- **Liquid propane vapor (LPG) is heavier than air and collects in lower places.**
- **Extreme caution should be taken when working on a new installation or while performing general maintenance.**
- **Do not smoke when near the unit.**
- **Keep flames, sparks, pilot lights, arc-producing equipment, switches and all other sources of ignition well away. Keep a type ABC fire extinguisher handy.**
- **Potential for fire or explosion always exist when using natural gas (NG) or liquid propane vapor (LPG) as a fuel source. Install this unit in compliance with all local fuel codes.**
- **Do Not operate engine if smell of fuel is present or other explosive conditions exist.**

FUEL HOOKUP

After electrical connections are complete, the next installation step is to connect a fuel supply to the unit. The fuel inlet fitting supplied with the generator is male ½" NPT and is located adjacent to a fuel access hole in the lower engine end panel as illustrated in Fig E. To accommodate potential settling of the generator relative to rigid supply pipeline, use of a flexible line to make the final connection in the supply line is suggested. When making flexible connections, use only materials rated for the fuel supplied and approved for use by local, regional or national codes and/or regulatory agencies.

⚠ DANGER ⚠



- All fuel system installations **MUST BE** done by a licensed plumber or licensed gas technician and must comply with all applicable codes, standards and regulations.

⚠ WARNING ⚠



- Natural Gas and Propane Vapor are highly explosive gases. Check **ALL** fuel system connections for leaks before starting engine/generator set.
- **DO NOT** use a flame to check for leaks.
- Use approved equipment and methods to check for leaks.

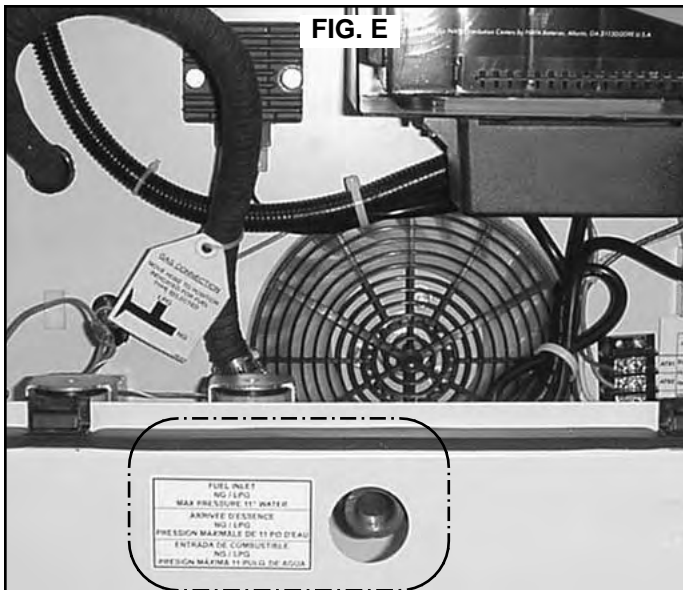

Natural Gas (NG)

When supplying natural gas as the operating fuel, provide fuel with a minimum of **1000 BTU/ft³ at inlet pressures between 7" and 11" of water column (4 - 6 oz)**. Failure to meet these minimums will cause the generator to run poorly and/or may limit output to values below nameplate value. If fuel with these qualities is not available, a low calorific fuel system kit may be required, at additional cost. Contact the customer service center to determine if a kit is required in cases of inadequate fuel quality.

Refer to the Fuel Consumption Table on page 13 for fuel flow requirements for the unit installed. Size all feeding piping to deliver sufficient flow above the minimum pressure of 7" water column (4 oz).

Per the National Gas Code (NFPA 54 - ANSI 2223.1), a manual shutoff valve in the fuel supply line to the generator is recommended.

Once all external connections are complete, check the position of the flexible engine supply hose, as shown in Fig F. When configuring a generator to run on a specific fuel, it is necessary to verify correct positioning of the hose on the fuel pressure regulator outlet. The factory default position is for natural gas (NG), as indicated in Fig F. If the fuel hose is not in the proper position, move it to the tee branch labeled NG, making sure the brass cap is placed securely on the opposite branch. With fuel supply attached and the flexible engine supply hose on the proper branch of the regulator output, the fuel hookup is complete. The generator is supplied with a fixed orifice tuned to provide proper fuel flow and no further adjustment of the fuel system is possible or required.

Propane Vapor (LPG)

In cases where liquefied propane vapor is selected as the fuel of choice, insure fuel delivery in the gaseous state, with a minimum energy content of **2500 BTU/ft³**, **at inlet pressures between 7" and 11" of water column (4 - 6 oz)**. Fuel below these specifications may cause improper engine operation and/or failure to deliver rated generator output. Size all fuel system plumbing to provide fuel flow as given in the Fuel Consumption Table on page 13, at a minimum pressure of 7" water column (4 oz).

After completing external supply connections, verify proper positioning of the flexible engine supply hose on the fuel pressure regulator output, as shown in Fig F. The factory default position is for natural gas (NG), requiring a change for liquefied propane vapor (LPG) operation. If the fuel hose is not in the proper position, move it to the tee branch labeled LPG, making sure the brass cap is placed securely on the opposite branch. With fuel supply attached and the flexible engine supply hose on the proper branch of the regulator output, the fuel hookup is complete. The generator is supplied with a fixed orifice tuned to provide proper fuel flow and no further adjustment of the fuel system is possible or required.

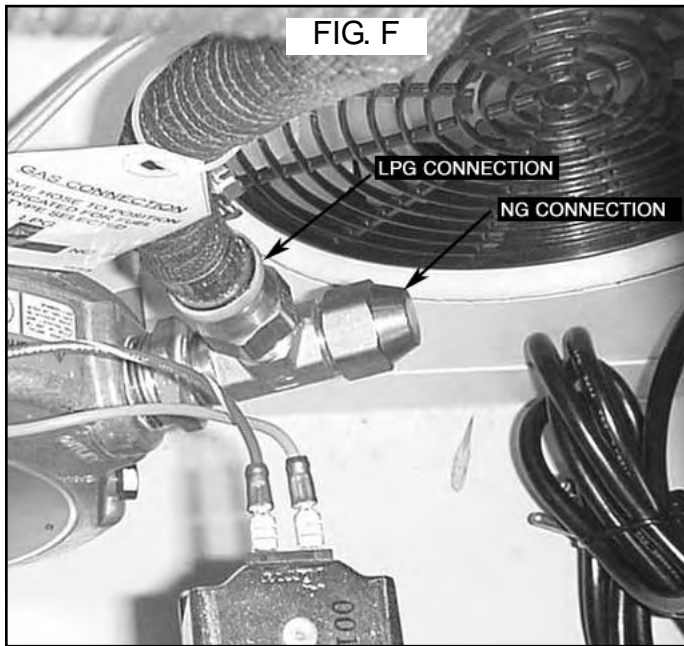

BATTERY REQUIREMENTS

To insure reliable starting in most weather conditions, it is important to properly match a battery to the requirements of the generator. The generator uses a 12 Volt, direct current, negative ground control system powered by an automotive style lead acid battery. Successful engine starting is dependent upon the cranking speed of the engine, which in turn is affected by the cranking capacity of the battery. When selecting a battery, choose the model that provides the highest available cold cranking amperes (CCA) within a given size range, as specified by the Battery Council International (BCI). The battery tray and cables supplied with the generator are sized to accept either a **BCI Group 26 or 26R battery**, with a minimum recommended rating of **450 CCA**.

WARNING

Lead-acid batteries present a risk of fire because lead-acid batteries generate flammable hydrogen gas.

- Do not smoke when near batteries.
- Do not cause flame or spark in battery area.
- Discharge static electricity from body before touching batteries by first touching a grounded metal surface.
- Do not dispose of batteries in a fire. The battery is capable of exploding.
- Do not open or mutilate the battery or batteries. Released electrolyte has been known to be harmful to the skin and eyes and to be toxic.

WARNING

The electrolyte is a dilute sulfuric acid that is harmful to the skin and eyes. It is electrically conductive and corrosive. The following procedures are to be observed.

- Wear full eye protection and protective clothing.
- Where electrolyte contacts the skin, wash it off immediately with water.
- Where electrolyte contacts the eyes, flush thoroughly and immediately with water and seek medical attention.
- Spilled electrolyte is to be washed down with and acid neutralizing agent. A common practice is to use a solution of one pound (500 grams) bicarbonate of soda to one gallon (4 liters) of water. The bicarbonate of soda solution is to be added until the evidence of reaction (foaming) has ceased. The resulting liquid is to be flushed with water and the area dried.

CAUTION



A battery presents a risk of electrical shock and a high short circuit current. The following precautions are to be observed when working on batteries:

- Remove watches, rings or other metal objects.
- Use tools with insulated handles.
- Wear rubber gloves.
- Do not lay tools or metal parts on top of batteries.
- Disconnect charging source prior to connecting or disconnecting battery terminals.
- Determine if the battery is inadvertently grounded. When inadvertently grounded, remove source of ground. Contact with any part of a grounded battery is capable of resulting in electrical shock. The risk of such shock is reduced when such grounds are removed during installation and maintenance.
- Failure to connect and disconnect in the proper sequence can cause equipment damage. Ensure there is a clean tight fit from the cables to the post.

BATTERY PLACEMENT AND CONNECTION

The next step in installation of the generator is placement and connection of the engine cranking battery. Provided battery cables and battery rack are sized to accept a **BCI Group 26 or 26R** automotive style battery. A battery with a minimum of **450 CCA** (cold cranking amperes) in this size range is recommended to assure reliable engine starting.

WARNING



- Make sure the control panel Mode switch is in the OFF position before connecting the battery cables. Failure to do so may result in unexpected engine starting and to personal injury.

BATTERY PLACEMENT AND CONNECTION (cont.)

To install the battery, begin by placing the battery (A) into the battery rack as shown in Fig G. Orientation of the battery terminals is according to installer preference as the supplied battery cables are of adequate length to reach terminals regardless of battery direction. Secure the battery to the rack using the J-bolts (B), nuts (C) and battery strap (D) packed in the literature bag packed with the unit, as illustrated by Fig G.

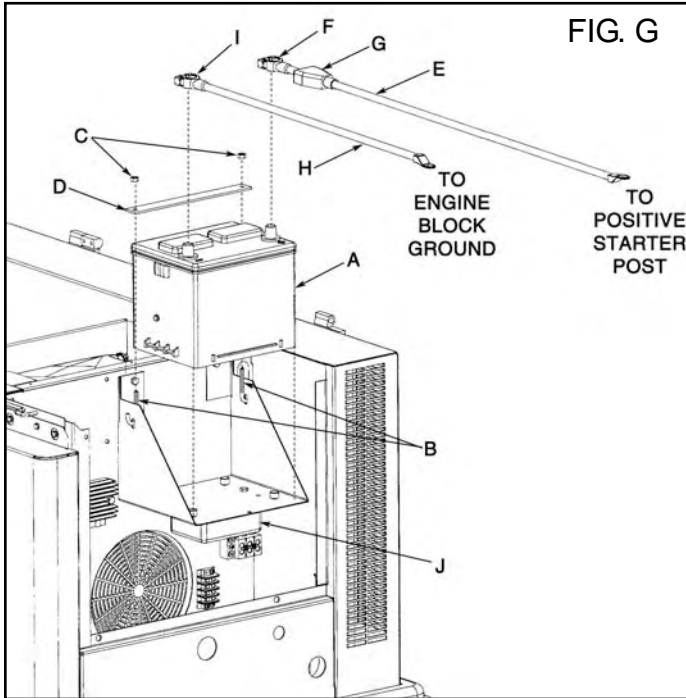

After the battery is tight in the rack, begin attaching the battery cables to the battery posts, starting with the positive (+), or red, cable (E). Loosen the bolt (F) on the post clamp slightly to allow the clamp to expand, then firmly push the clamp onto the battery post marked positive (+) until the top of the post extends past the top of the clamp. Rotate the clamp around the post as required to insure the clamp cannot contact any metal components, then tighten the clamp bolt (F) until snug. Finally, slide the post boot (G) down the cable and place it entirely over the clamp.

Finish connecting the battery by placing the negative (-), or black, battery cable (H) to the battery post marked negative (-). Push the clamp firmly over the post until the post extends past the top of the clamp, then rotate the clamp to avoid contact with any metal parts. Tighten the battery clamp bolt (I) until snug.

The final step of battery installation is to verify proper connection of all battery charger connections. A battery charging system (J) is included with the engine/generator set to maintain the battery charge during extended periods of generator inactivity, therefore providing consistent starting. A quick check of charger connections will verify that factory connections are correct so the charger can function as intended. Insure

that the charger is connected by checking to see that it is plugged into a powered GFCI receptacle, and that the positive (+) and negative (-) charger cables are connected to their respective battery cables.

LUBRICATION

Once all connections are made, the final installation step is verification of proper engine oil level. The engine is factory filled and shipped with approximately 1.5 qt (1.4 liters) of SAE 10W-30 weight oil. Begin the level check by removing the dipstick (K), wiping it clean, then reinserting it into the engine, checking that the oil level falls between the upper and lower limit marks (see Fig A ,page 26) on the end of the dipstick. Adjust engine oil level as required so the level is at the upper limit mark on the dipstick, adding oil to the engine through the oil fill cap (L) as shown in Fig H.

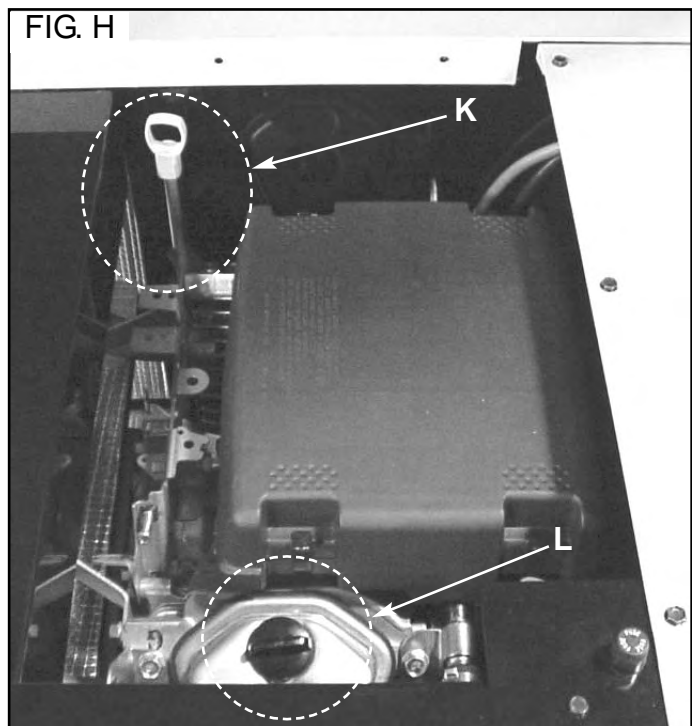

WARNING



- State and federal agencies have determined that contact with used engine oil can cause cancer or reproductive toxicity. Take care to limit skin contact and breathing of vapors as much as possible. Use rubber gloves and wash exposed skin.

CAUTION

- Any attempt to crank or start the engine before it has been properly serviced with the recommended oil will result in an engine failure that is not covered by warranty.

FIRST TIME STARTUP

After completing all installation procedures, read and understand the operating instructions for the generator controller. Know how the control panel operates, what to expect when activating control panel switches and how to shut the generator off in the event of an emergency. Before starting the generator for the first time, check off all items on the following list, then follow the given procedure to verify correct operation of the generator.

- Is unit level?
- Is adequate free air space (3 feet minimum) available on all sides of the enclosure?
- Are all cabinet openings free from blockage?
- Is the exhaust directed away from dwellings, dwelling air intakes, or combustible materials?
- Are the fuel supply lines and internal generator fuel connections leak-free?
- Is fuel supply pressure within specifications?
- Is the regulator connection properly configured for the fuel supplied?
- Is an approved transfer switch used to prevent backfeed into utility lines?
- Are electrical connections tight, and properly connected?
- Are electrical conductors sized properly?
- Is the engine filled to the proper level with the correct type of oil?
- Is a properly sized engine cranking battery correctly installed?
- Is the battery maintenance charger plugged in and operating correctly?
- Are all protective covers installed and tightened?
- Are all tools clear of moving or electrically live parts?
- Is the installation inspected and approved as required by local or regional code?

Once all items on the checklist are marked off, complete the initial startup using the listed steps.

DANGER



- **Contact with high voltages present in generators and utility systems can cause severe electric shock or death. Avoid contact with all live components.**
- **Allow only qualified generator service technicians or licensed electricians to perform initial system start-up.**

1. Place the control panel mode switch on the generator in the OFF position.
2. Move the main line circuit breaker handle on the generator to the OFF position.
3. Check the utility, or preferred, power supply to the transfer switch following the instructions provided by the switch manufacturer.
4. Ensure utility power to the transfer switch is shut off.

5. Return to the generator and open any manual shutoff valves in the fuel supply system.
6. Move the control panel mode switch to the RUN position. The generator should crank and start.
7. Allow the generator to run for approximately three (3) minutes, then move the main line circuit breaker handle to the ON position.

DANGER



- **Generator is now supplying dangerous voltages. Use extreme caution performing electrical checks.**
8. Check across the terminals of the main line power output block (Red to Black) for proper frequency and voltage. Frequency should read approximately 62.5 Hz and voltage between 240 and 245 volts at no load conditions.
 9. Adjust no load speed as required to meet approximately 62.5 Hz.
 10. Shut the generator down by moving the mode switch back to the OFF position.
 11. Restore utility power to the transfer switch.
 12. Place the control panel mode switch on the generator set in the AUTO position.
 13. Perform a manual exercise cycle following the instructions provided by the switch manufacturer. If wiring is connected properly to the switch, the generator will start and stop under switch control. While the generator is running, check the voltage and frequency across the emergency supply terminals on the transfer switch. Values should match those found in Steps 8 and 9.
 14. Allow the transfer switch to shut the generator off by letting it complete the manual exercise cycle.
 15. With the generator mode switch still in the AUTO position, simulate utility power failure by switching utility power to the transfer switch OFF. Verify correct function of the automatic transfer switch as indicated in the switch manual. Restore utility power to the transfer switch and verify correct automatic transfer switch function. Allow the switch to shut the generator down.
 16. Inspect the site to ensure no packaging or installation materials remain within or against the generator.
 17. Replace all covers on the generator.
 18. Place the generator into service by moving the mode switch to the AUTO position.

CAUTION

- **Failure to set the controller to AUTO before leaving the generator renders the generator unavailable for automatic standby service.**

GENERATOR SPECIFICATIONS

	PM401211	PM400911
Rated Output		
Propane Vapor	11.2 kW	9.7 kW
Natural Gas	9.5 kW	8.2 kW
Rated Amperage		
Propane Vapor	46.7 A	40.4 A
Natural Gas	39.6 A	34.2 A
Rated Voltage	240 V	240 V
Frequency	60 Hz	60 Hz
Phase	Single	Single
Circuit Breaker Size	50 Amp	45 Amp
Rated Operating Temperature	-20°F to 104°F (-29°C to 40°C)	-20°F to 104°F (-29°C to 40°C)
Cooling Airflow	977 ft ³ /min	977 ft ³ /min
Full Load Sound Level	69 dB(A)*	68 dB(A)*
Overall Dimensions	42 1/2 in x 32 in x 27 in	42 1/2 in x 32 in x 27 in
Weight	478 lb	476 lb

ENGINE SPECIFICATIONS

	PM401211	PM400911
Manufacturer	Honda	Honda
Manufacturer Engine Model	VXC-GDACM	VXC-GDADM
Style	Air cooled, V-twin, 2-cylinder	Air cooled, V-twin, 2-cylinder
Block	Aluminum	Aluminum
Displacement	670 cc (40.9 in ³)	614 cc (37.5 in ³)
Bore	3.0 in (77 mm)	3.0 in (77 mm)
Stroke	2.8 in (72 mm)	2.6 in (66 mm)
Compression Ratio	8.3:1	8.3:1
Exhaust Flow	102 ft ³ /min	93 ft ³ /min
Exhaust Temperature	1007 °F	1007 °F
Oil capacity		
without filter	1.2 US qt (1.1 l)	1.2 US qt (1.1 l)
with filter	1.5 US qt (1.4 l)	1.5 US qt (1.4 l)
Oil Filter	Honda # 15400-P0H-305PE	Honda # 15400-P0H-305PE
Air Filter (paper element)	Honda # 17210-ZJ1-841	Honda # 17210-ZJ1-841
Spark plugs	NGK # ZGR5A or Denso # J16CR-U	NGK # ZGR5A or Denso # J16CR-U
Spark plug gap	0.12 - 0.16 in (0.30 - 0.40 mm)	0.12 - 0.16 in (0.30 - 0.40 mm)
Valve Clearance		
Intake	0.005 - 0.007 in (0.13 - 0.17 mm)	0.005 - 0.007 in (0.13 - 0.17 mm)
Exhaust	0.007 - 0.009 in (0.18 - 0.22 mm)	0.007 - 0.009 in (0.18 - 0.22 mm)

* Average @ 7 m

ALTERNATOR SPECIFICATIONS

	PM401211	PM400911
Style	2 pole, brushless	2 pole, brushless
Synchronous Speed	3600 RPM	3600 RPM
Excitation	Self regulated	Self regulated
Motor Starting Capacity	12 sKVA [†]	12 sKVA [†]
Winding Resistances		
Stator	0.30 – 0.50 Ω	0.30 – 0.50 Ω
Excitation	1.4 – 1.6 Ω	1.4 – 1.6 Ω
Rotor	5.9 – 6.0 Ω	5.9 – 6.0 Ω
Capacitors	40μF, 500V	40μF, 500V

ELECTRICAL SPECIFICATIONS

	PM401211	PM400911
Battery	12 VDC, BCI Group 26 or 26R	12 VDC, BCI Group 26 or 26R
Minimum CCA	450	450
Maintenance charger	6 Amp, 3 stage	6 Amp, 3 stage
Fuse	14 Amp, 32 VDC, Type SFE	14 Amp, 32 VDC, Type SFE
Engine Alternator	10 Amp regulated	10 Amp regulated
Fuse	25 Amp, 32 VDC, Type 3AG	25 Amp, 32 VDC, Type 3AG
Fuel Solenoids		
Opening Voltage	9.5 VDC	9.5 VDC
Coil Resistance	29.1 - 29.8 Ω	29.1 - 29.8 Ω
Oil Pressure Switch	14 psi Normally open, close on rise	14 psi Normally open, close on rise
High Temp Switch	285°F, Normally open, close on rise	285°F, Normally open, close on rise

FUEL SPECIFICATIONS

	PM401211	PM400911
Fuel Pressure	7 – 11 inches water (4 – 6 oz)	7 – 11 inches water (4 – 6 oz)
Fuel Consumption (100% load)		
Propane Vapor	81 ft ³ /hr (2.2 Gal/hr)	79 ft ³ /hr (2.1 Gal/hr)
Natural Gas	186 ft ³ /hr	176 ft ³ /hr
Min Energy Content		
Propane Vapor	2500 BTU/ft ³	2500 BTU/ft ³
Natural Gas	1000 BTU/ft ³	1000 BTU/ft ³

[†] Measured @ 30% instantaneous voltage dip

GENERATOR FEATURE IDENTIFICATION

Before installing, operating or maintaining the generator, take a few moments to become familiar with the features of the generator as illustrated.

1. CONTROL PANEL

Controls the operation of the generator and communicates system status.

2. MAIN LINE CIRCUIT BREAKER

Protects generator and connected loads from electrical faults. Used to isolate output power from operating generator.

⚠ WARNING ⚠



- Place the circuit breaker in the OFF position when servicing the generator to minimize electrocution hazards.

3. GFCI OUTLET

Supplies power to at-rest battery charger and optional block heater. Standard plug receptacle also allows convenient location to power a light or tools during maintenance.

4. CRANKING BATTERY (not included)

Supplies power to start engine and keep control panel active.

5. CRANKING BATTERY CHARGER

Maintains cranking battery at proper level during

periods of inactivity to insure reliable, consistent starting.

6. BATTERY CHARGING CIRCUIT FUSE

Protects engine - mounted battery charging circuit against damage from electrical faults.

7. FUEL REGULATOR/LOCKOFF SOLENOIDS

Controls fuel flow to engine.

8. INTERCONNECTION TERMINAL BLOCKS

Provided for quick connection of generator wiring to transfer switch during generator installation.

9. OIL LEVEL DIPSTICK

High visibility yellow dipstick for checking for proper engine lubricating oil level.

10. OIL FILL PLUG

Add fresh engine oil here as required.

11. SPIN ON OIL FILTER

Replaceable, disposable filter to remove contaminant's from engine oil to prolong engine life.

12. OIL DRAIN VALVE

Quick turn ball valve with extended drain hose to speed up maintenance and eliminate mess.

13. ENGINE AIR FILTER

14. LID SUPPORT ROD

15. FRONT SERVICE ACCESS PANEL

Remove to drain oil and change oil filter.

16. CONTROL PANEL CIRCUIT FUSE

Protects control panel against damage from electrical faults.

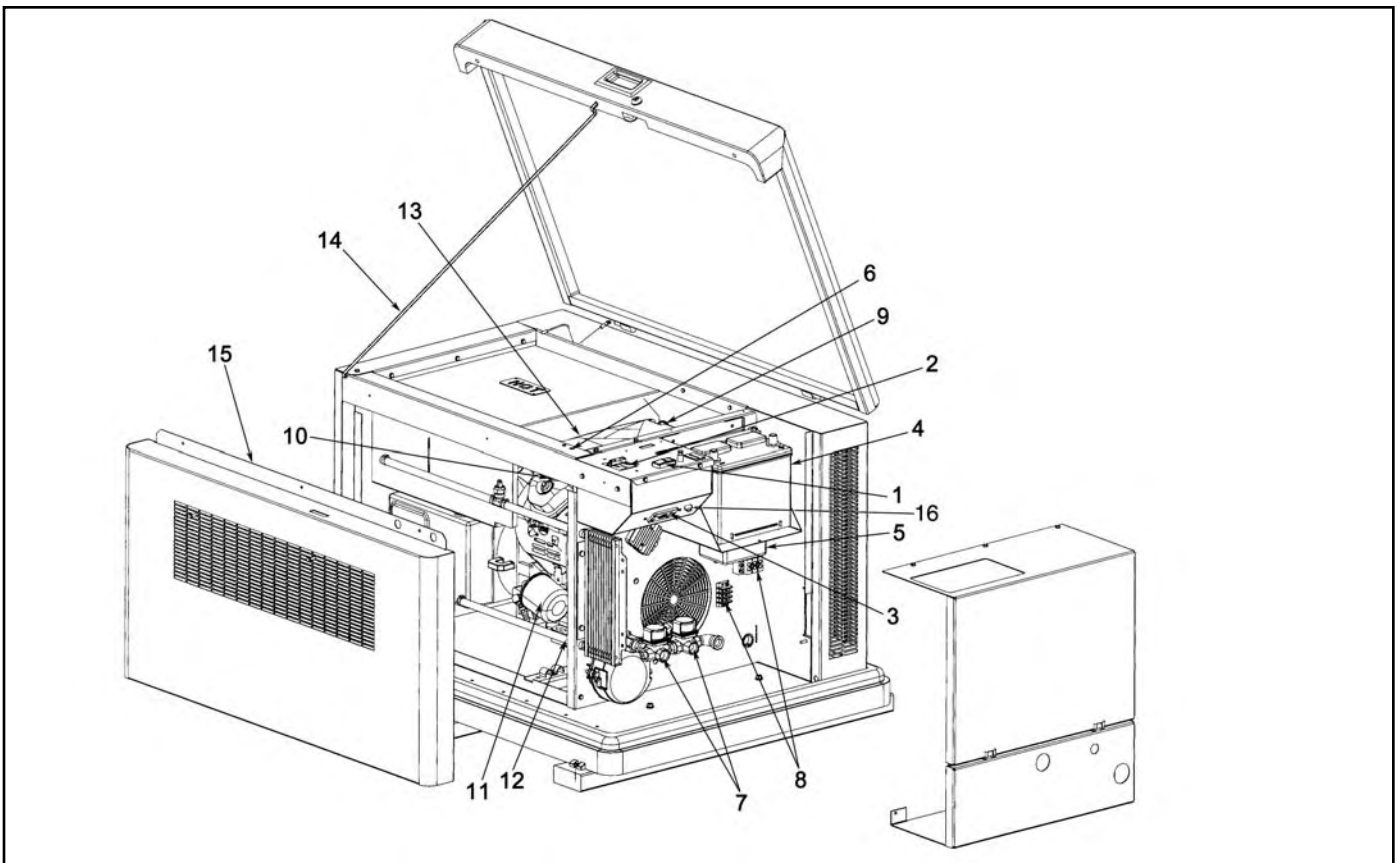

GENERATOR OPERATION

A standby generator is an engine driven air cooled system to convert the energy contained in either liquid propane vapor or natural gas to electrical power. When coupled with an automatic transfer switch to monitor for failure of utility power, the unattended system can start, stop and transfer between sources to insure a nearly seamless supply of power. The generator is housed in a weather resistant, sound attenuated enclosure for outdoor installation only.

Before installing and starting the generator, become familiar with the controls and operational features of the generator. Know how the control panel operates, what to expect when activating control panel switches and how to shut the generator off in the event of an emergency.

CONTROL PANEL FEATURES

- A. MODE SWITCH
- B. CIRCUIT BREAKER
- C. STATUS INDICATOR LIGHTS
- D. HOUR METER
- E. LAMP TEST SWITCH

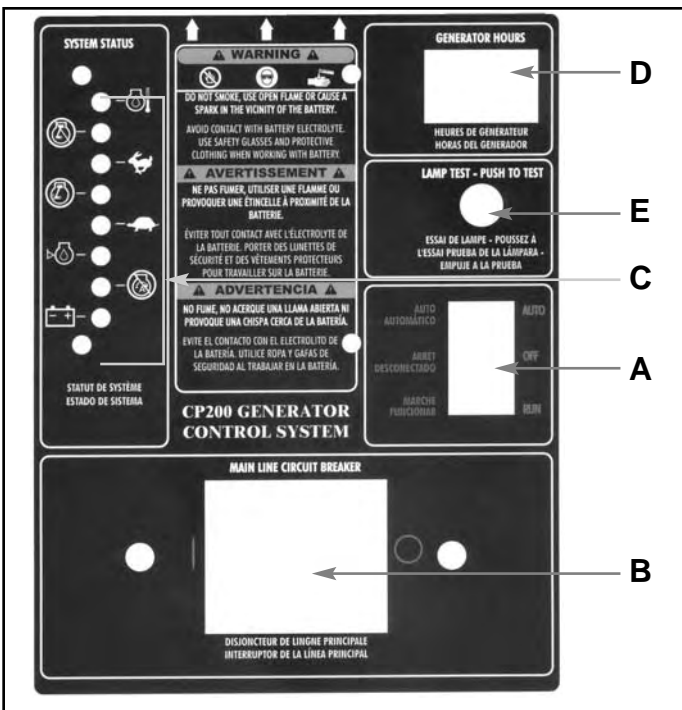

CONTROL PANEL SWITCHES

A. Mode Switch

The Mode switch is used to set the operating state of the generator. Placing the switch in the OFF position prevents engine operation or stops the engine if it is already running. Moving the switch to the RUN position immediately starts the generator. Putting the switch in

the AUTO position sets the generator for unattended operation under the control of properly matched automatic transfer switch.

B. Main Line Circuit Breaker

A Main Line Circuit Breaker is provided to protect the generator from damage caused by electrical faults within the attached electrical distribution system. It is also used to isolate the output of the generator from the connected electrical distribution system by moving the breaker handle to the OFF position. Placing the breaker in this position does not prevent startup of the generator.

C. Status Indicator Lights

Status indicator lights are provided to communicate the status of the generator to the user. Under normal running conditions, only the green Generator On light is lit. Function of all other lights are described on page 24.

D. Generator Hour Meter

The Generator Hour Meter is provided to track the total numbers of hours of operation. The hour meter runs whenever the engine is running and the alternator is producing electricity. Placing the main line circuit breaker in the OFF position while the engine is running does not stop the meter from counting hours.

E. Lamp Test Switch

A lamp test switch is provided to check for function of all indicator lights. Press the lamp test switch while the engine is at rest, with the control panel mode switch in the OFF position to illuminate all status lights.

F. Engine Charging Circuit Fuse

The Engine Charging Circuit Fuse provides protection to the engine mounted alternator in the event of electrical faults in the positive (+) battery circuit. Failure of this fuse prevents charge from reaching the battery when the generator is running, leading to early battery failure. Replace the fuse only with an equivalent size and style of fuse to prevent damage to the generator electrical control system.

STARTING THE GENERATOR

Two methods are available to start the generator. The automatic, or AUTO mode is for use with an automatic transfer switch. With the control panel mode switch set to this position, the generator waits for an external signal to start. This signal is supplied by the transfer switch when utility power is of unacceptable quality. Since utility power can fail at any time, be aware **the generator can start unexpectedly whenever in the AUTO position. Keep away from moving parts at all times.** Once utility power is once again acceptable, the signal from the transfer switch is removed, the generator shuts off, then returns to waiting for another signal to start.

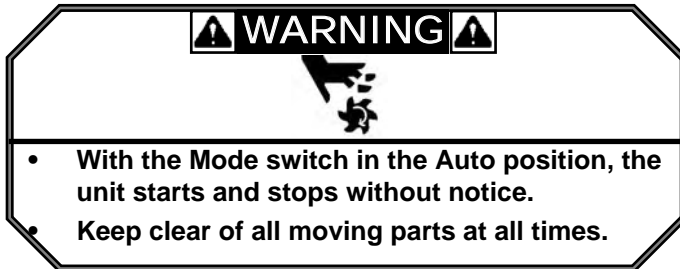

The other method for starting the generating is to place the mode switch into the RUN position. This mode is intended for generator control during maintenance or if an automatic transfer switch is not used. With the control panel switch shifted to this position, the generator will immediately attempt to start after a brief pause. Upon starting, the generator runs until the switch is moved from the RUN position, at which time the generator will shut off.

CYCLIC CRANK

To insure the generator starts without damaging the starter motor, cranking of the engine is performed in a cyclic manner. When the generator is started from either the AUTO or RUN positions, the controller alternates between 10 seconds of engine cranking, followed by 10 seconds of engine rest. If the engine starts during any of the cranking periods, crank attempts are halted and the controller begins monitoring for proper function of the generator. In the event that three 10 second start attempts occur without the engine starting, cranking attempts are halted and the Overcrank light is lit.

RUN STATE

After the engine is started and the generator is producing electrical power, the controller begins operation in a monitoring state. In this state, several generator functions are continuously checked to ensure proper operation of the generator. If functions are determined unacceptable, a fault is declared, the engine is shut down and a status light is lit to communicate the reason for the shutdown.

SHUTDOWN

When operating with the control panel switch in the RUN position, the generator will continue to run until a

fault is declared or until the mode switch is moved to the OFF position. Once the switch is shifted to the OFF position, the engine is shut off.

When operating with the control panel switch in the AUTO position, the generator continues to run until a fault light is declared or the run signal is removed. Once the signal is removed, the engine shuts down and the controller returns to waiting for a start signal.

STATUS INDICATORS

Status indicator lights relay conditions of generator function for user or service technician convenience. Illumination of these indicator lights communicate conditions that require generator service but are not severe enough to cause damage if the generator is allowed to operate. Contact a qualified service technician immediately for service if any of the listed lights are lit, even if the generator appears to function normally.

A. LOW BATTERY

The Low Battery light is lit when the cranking battery voltage falls below 11.0 volts. At this level, the battery begins to lose the ability to consistently start the engine. Causes of low battery voltage may include a failing battery, failed battery charger or failed engine alternator.

B. NOT IN AUTO

The Not In Auto light is lit whenever the control panel mode switch is not placed in the AUTO position. This light is provided to call attention to this condition since the generator cannot start automatically during a power outage without the switch in the AUTO position. It is normal for this lamp to light when the generator is running with the mode switch in the RUN position, or if the switch is in the OFF position. To turn the light off, move the mode switch to the AUTO position.

H. GENERATOR ON

The Generator On light illuminates when the generator's engine is running. This is the only light lit when the generator is supplying power as intended.

FAULTS

Fault lights relay conditions that may cause damage to the generator and/or loads connected to the output of the generator. When any of the listed situations occur while the generator is running, the generator is shut down and the fault light associated with the shutdown cause is lit. Once the light is lit, it remains on until it is cleared by moving the control panel mode switch to the OFF position. If a fault light is lit, determine and correct the cause of the problem before restarting the generator. During generator starting, the controller ignores fault conditions until 15 seconds after the generator starts, then uncleared faults will once again cause the generator to shut off. To determine possible fault causes, refer to the troubleshooting section of this manual or contact a qualified service technician for assistance.

C. OVERCRANK

The Overcrank light is lit if all three 10 second cyclic crank attempts are unsuccessful in starting

the engine. Once the light is on, the generator does not attempt to start until the fault is reset. When the Overcrank light is on, verify fuel is available at the inlet to the unit, then check the condition of the cranking battery.

D. LOW OIL

The Low Oil light turns on and the engine is shut off if the engine oil level falls too low. To avoid engine damage, engine oil pressure is monitored to determine the amount of oil in the engine. When pressure falls below a preset level, a Low Oil fault occurs. Check for proper oil level if the generator shuts down due to a Low Oil alarm.

E. HIGH TEMPERATURE

The High Temperature light illuminates if the temperature of the engine becomes too high. Engine oil temperature is monitored while the engine is active and the engine is shut off to avoid damage if the oil temperature becomes too high. When operating the generator in temperatures above the maximum listed on the nameplate, it is necessary to reduce the load connected to the generator to avoid overheating. If high ambient temperatures or excessive loads are eliminated as possible causes of High Temperature shutdown, check to insure cabinet openings are not restricted by debris.

F. OVERSPEED

The Overspeed light is turned on if the generator engine is running too fast. Electrical output of the generator at high speeds may damage loads connected to the generator output and/or engine failure may occur at excessive speeds. If the generator shuts down on an Overspeed error, seek assistance from a qualified generator service technician.

G. UNDERSPEED

The Underspeed light is turned on if the generator engine is running too slow. Electrical output of the generator at low speeds can damage loads connected to the generator output and/or generator failure may occur due to excessive heating in the generator head. If the generator turns off due to an Underspeed error, check to see that the connected loads do not exceed the nameplate rating of the generator.

MAINTENANCE

To ensure reliable generator operation, it is critical to periodically inspect all components. The following chart is provided as a guide for service check intervals. When the generator is operated under excessively hot, or dusty conditions, shorten service intervals according to the severity of the conditions encountered. To perform periodic inspections or maintenance, refer to the

procedures listed in the following sections. A qualified generator service technician should perform inspections or adjustments requiring specialized tools or training. Users unfamiliar with any of the listed procedures should contact an authorized dealer for servicing assistance.

Maintenance Item		Every month or 15 hours	Every 6 months or 100 hours	Every year or 300 hours	Every 2 years or 500 hours
Engine Oil	Check	X			
	Change		X ¹		
Engine Oil Filter	Change		X		
Oil Cooler	Check and Clean		X		
Engine Air Filter	Check	X			
	Change			X	
Battery	Check and Clean		X		
Battery Charger	Check		X		
Spark Arrestor	Check and Clean			X	
Spark Plugs	Check			X	
	Replace				X
Valve Clearance	Check and Adjust			X	
Generator Output Frequency	Check and Adjust			X	
Fuel System	Check		X		
Cooling Air Openings	Check	X			

1. Perform first change at 25 hours.

⚠ WARNING ⚠



- Before performing any maintenance, make sure the Mode switch is in the OFF position, the circuit breaker is in the OFF position and the positive (red) battery cable is disconnected.
- Generator/engine components are hot to the touch when operating. To prevent burns to the skin allow unit to cool before touching internal generator or engine components.
- Crankcase pressure can blow hot engine oil out the fill opening causing severe burns. Always stop the generator before removing the oil fill cap.
- Keep hands, feet, clothing, etc., away from drive belts, fans, and other moving or hot parts. Never remove any drive belt or fan guard while the unit is operating.
- Engine block heater can cause electrical shock. Remove engine block heater plug from electrical outlet before working on block heater connections.
- Improper service or replacement of parts can lead to severe personal injury or death and to damage to equipment and property. Service personnel must be qualified to perform electrical and mechanical service.
- Use caution when working on live electrical equipment. Remove jewelry, make sure clothing and shoes are dry and stand on a dry wooden platform.
- Do not smoke around the generator. Wipe up any fuel or oil spills immediately. Ensure that no combustible materials are left in the generator compartment, or on or near the generator, as FIRE or EXPLOSION may result. Keep the area surrounding the generator clean and free from debris.
- When performing maintenance on this equipment, nothing should be done that might render the equipment or its installation in non-compliance with applicable codes, standards, and regulations.
- Eye protection should be used.

Prior to checking the oil level, start the generator by moving the Mode switch on the control panel to the RUN position. Allow the generator to run for one or two minutes, then shut it down by returning the switch to the OFF position. After the engine comes to a stop let the engine set for a couple of minutes before checking the oil level. Begin the level check by removing the dipstick (A), wiping it clean, then reinserting it into the engine. Remove the dipstick a second time, checking that the oil level falls between the upper and lower limit marks on the end of the dipstick, as shown in Fig. A. Adjust engine oil level as required so the level is at the upper limit mark on the dipstick, adding oil to the engine through the oil fill cap (B) as shown in Fig B. Add only oil of the same specification as the oil already in the engine.

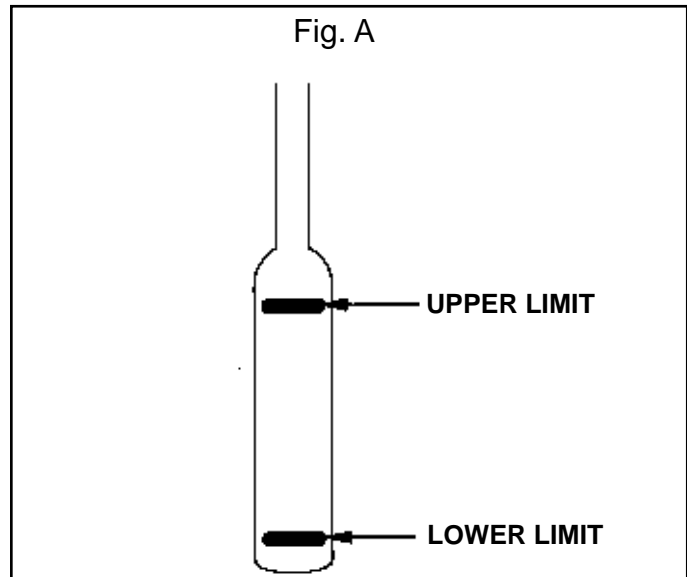
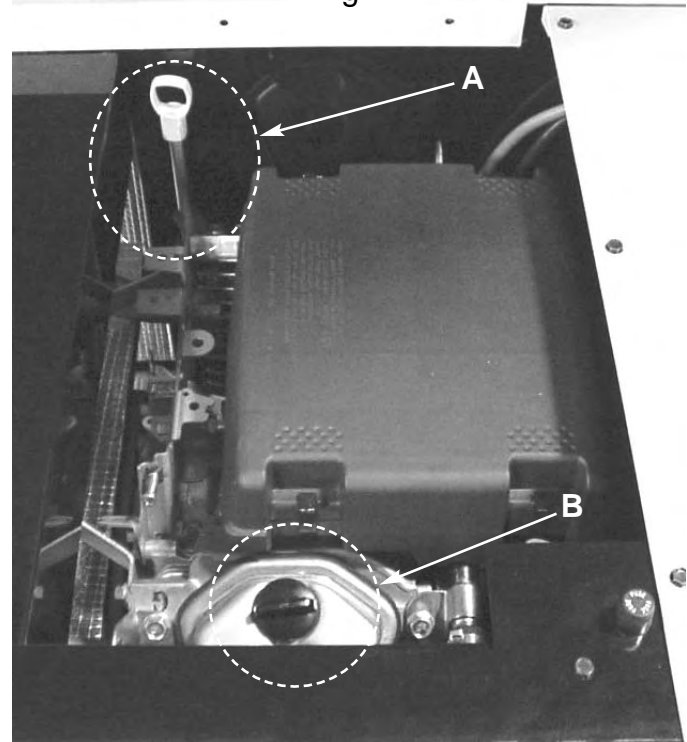
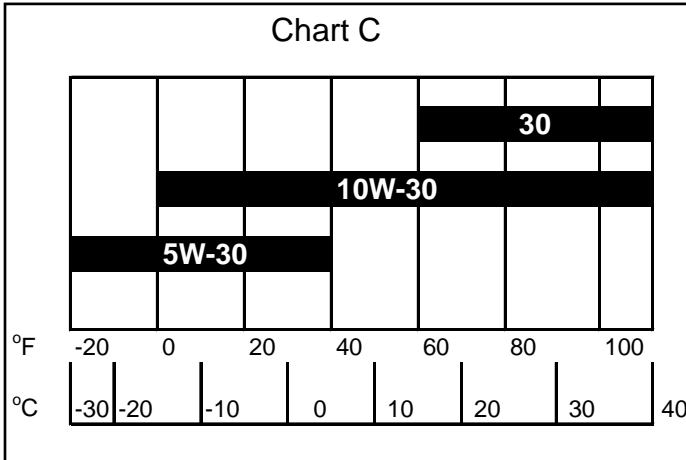

Fig. B



ENGINE OIL AND OIL FILTER CHANGE

Selection of the correct grade and type of engine oil greatly affects the performance of the generator, especially when starting. Before selecting replacement oil for an oil change, consider the anticipated operating conditions the generator may be exposed to. Choose the appropriate weight of oil for anticipated temperatures from Chart C. If temperatures are expected to fluctuate between extremes prior to the next oil change interval, use of synthetic oil is recommended. Use of oil meeting a minimum American Petroleum Institute (API) classification of SJ is advised.



- Place an oil drain pan capable of holding three (3) quarts under the end of the oil drain hose (A).
- Remove the oil fill cap (B) and place in a convenient location. While holding the end of the oil drain hose (A) in the drain pan, slowly open the oil drain valve (C) by turning the handle clockwise until the valve is fully open. Allow the engine oil to completely drain into the drain pan.
- When the engine oil is completely drained, close the valve (C) by turning the handle fully counterclockwise.
- Place the drain pan underneath the spin on oil filter (D), then remove the filter by turning it counterclockwise. Once loose, drain all of the oil from the filter into the drain pan.
- Apply a light film of oil to the gasket on the new oil filter, then screw the filter onto the adaptor until the gasket lightly touches the adaptor face. Tighten the filter an additional $\frac{3}{4}$ to 1 turn.
- Refill the engine with 1.5 qt (1.4 liters) of new engine oil through the engine oil fill cap (B). Refer to the engine oil recommendations on chart C for the proper grade of oil. Replace the oil fill cap (B), then start the engine and check for leaks.
- Stop the engine and check the engine oil level as outlined on page 26. Add oil as required to bring the oil to the proper level on the dipstick.

WARNING



- State and federal agencies have determined that contact with used engine oil can cause cancer or reproductive toxicity. Take care to limit skin contact and breathing of vapors as much as possible. Use rubber gloves and wash exposed skin.

CAUTION

- Any attempt to crank or start the engine before it has been properly serviced with the recommended oil will result in an engine failure that is not covered by warranty.

Engine oil changes are recommended at the maximum intervals given in the Periodic Maintenance Table. When operating in hot or dusty conditions shorter change intervals may be necessary. To change the engine oil and oil filter, the listed procedure is recommended.

- Warm up the engine oil by running a cold engine for a few minutes, then shutting it off. Start and stop the engine by moving the control panel mode switch between the RUN and OFF positions. Insure the mode switch is in the OFF position before continuing the oil change.

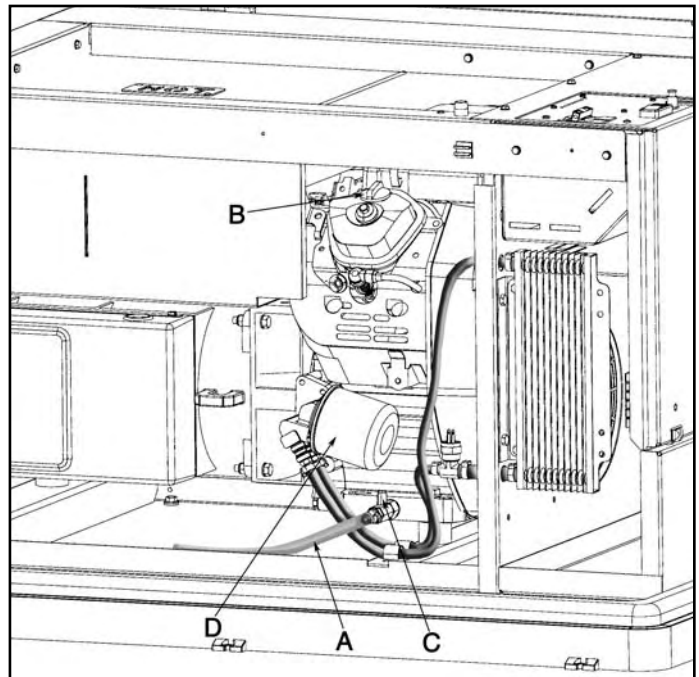

ENGINE OIL COOLER INSPECTION AND CLEANING

At the intervals given in the maintenance schedule table, check the oil cooler and lines for leaks. If leaks are detected, replace clamps, fittings or hoses as necessary. Also visually inspect the oil cooler for debris clogging the cooler fins. If the cooler is blocked, use low pressure air or water to dislodge the blocking material.

ENGINE AIR FILTER CHANGE

The generator engine is equipped with a dry element air filter to block particles in the combustion air from getting into the engine and causing excessive engine wear. Over time this dirt builds-up on the filter, restricting the amount of combustion air available to the engine, in turn leading to a loss of generator power output. To avoid these problems, periodic replacement of the engine air filter is recommended at the intervals outline in the service schedule table on page 25. To change the air filter, follow the listed steps.

CAUTION

- **Never run this equipment without the complete air cleaner system installed on the engine. Failure to do so will result in premature engine wear and significantly reduced engine life.**

1. Locate the air filter cover snaps as shown in Fig. D and pull them upward to release the cleaner cover.
2. Remove the air cleaner cover to access the filter elements, then remove the dirty paper filter element and foam element.
3. Carefully wipe the inside of the air cleaner housing and lid clean with a clean, lint-free rag, taking care not to knock dirt into the engine intake opening.
4. Wash the foam element in warm soapy water, rinse, and allow to dry completely. DO NOT oil the foam element.
5. Place the new paper filter element into the air cleaner housing, then re-install the foam filter.
6. Complete the replacement by putting the air cleaner cover back in position and snapping the cover snap closed.

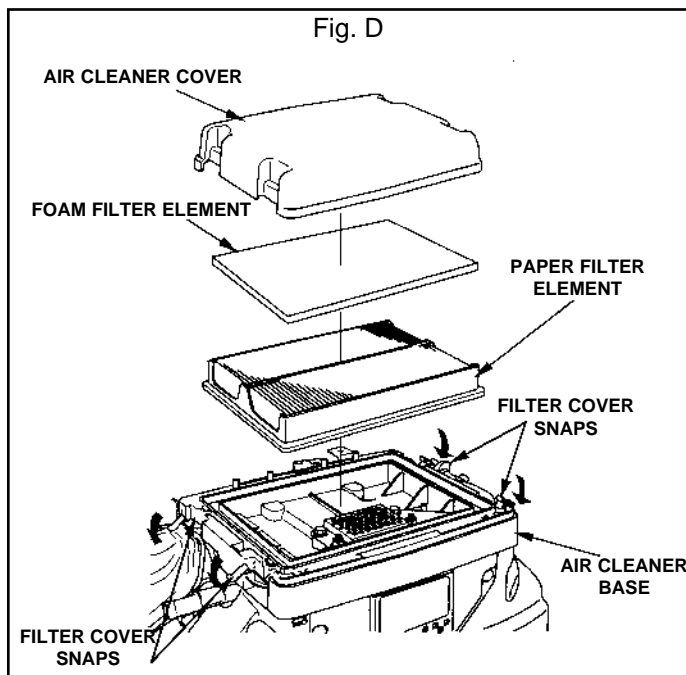

BATTERY MAINTENANCE

WARNING



- **Read and understand all warnings and cautions on page 16 of this manual before proceeding with any battery maintenance.**

Correctly maintaining the battery at regular intervals is vital to ensure consistent engine starting. Poorly maintained batteries loose charge over time and may not provide enough power to crank the engine fast enough for reliable starts. The steps below are suggested to care for the battery and charger.

1. Access the battery (A) by removing the 3 access panel screws (B) shown in Fig E using a 5/16" wrench. The hinge panel (C) is then rotated to expose the battery.
2. Keep the battery cable clamps at the battery posts tight and free of corrosion. Replace the battery cables if cracks are found in the clamps.
3. Check and adjust the level of battery electrolyte according to the battery manufacturer's instructions if not using a "maintenance-free" battery. If electrolyte is low, add only distilled water to the battery. Do not add tap water to the battery.
4. Use a battery hydrometer to check the condition of the electrolyte in each of the battery cells. Follow the instructions provided by the hydrometer manufacturer to assess the quality of the battery.

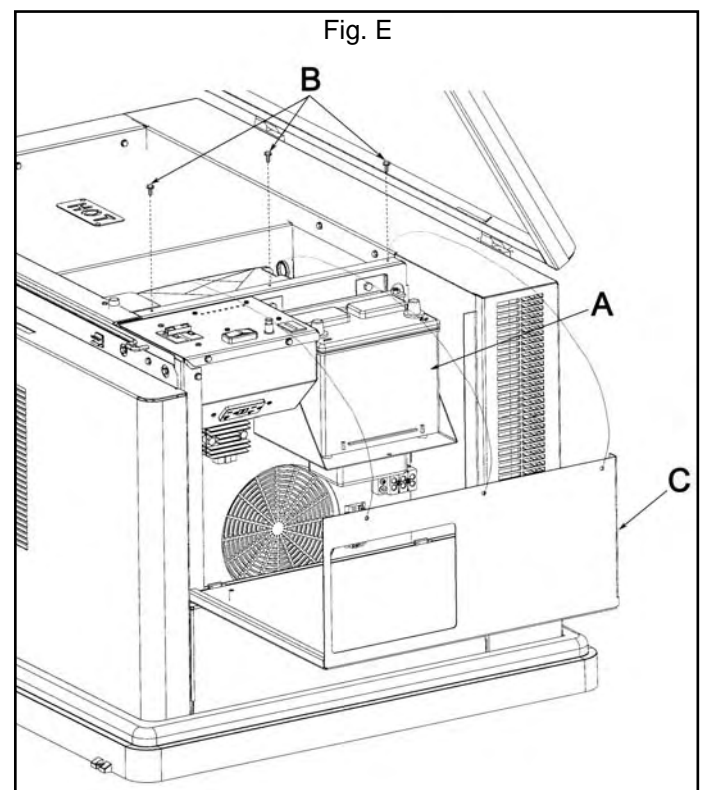

BATTERY MAINTENANCE (cont.)

5. Insure the the battery charger is powered and functioning properly. A correctly operating battery charger displays lights on the face of the charger to relay the state of the charger. To locate the battery charger (A) and check the lights (B) (see note below) refer to Fig F. Refer to Table A to assess the mode the charger is operating in.

Note: For easy viewing of the battery charger lights, use a small handheld mirror held under the charger.

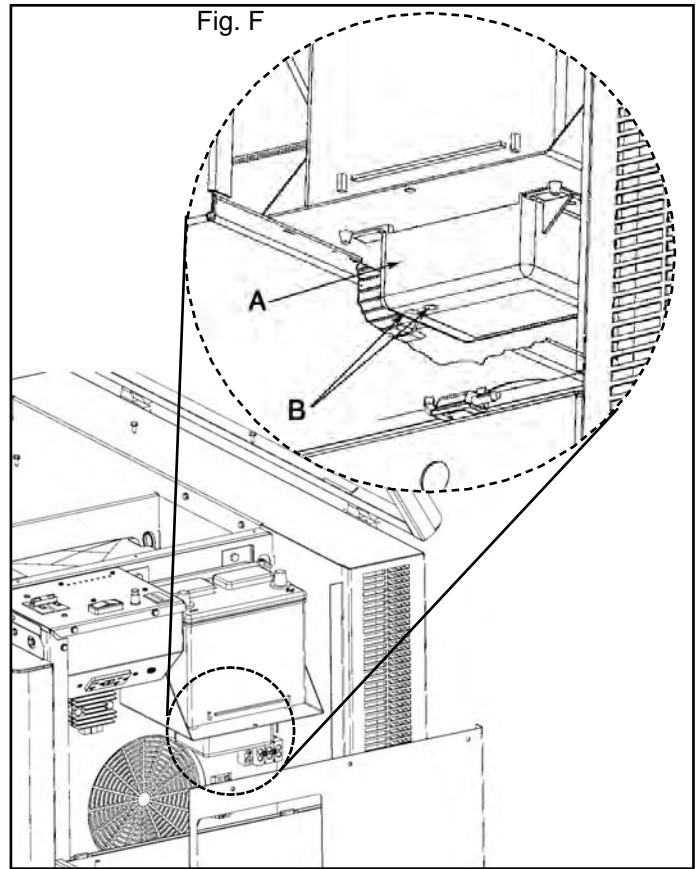

Table A

Display		Operating Condition
Red		•When the red LED is on, it indicates that your battery is discharged and the charger is recharging at the "BULK" rate of 6 Amps. •While the red LED is on, the voltage measured will be 11.8 to 14 volts. •If the red LED stays on for more than 24 hours, refer to the troubleshooting section of this manual.
Green		
Red		•When both the green and the red LED's are on, the charger is charging at an "ABSORPTION" rate of between 1.5 and 5 Amps. This mode of charging gradually "tops off" the battery, and reduces harmful sulfating. •While both LED's are on, the voltage measured should be approx. 14.0 to 14.5VDC. •If both LED's stay on longer than 24 hours, refer to the troubleshooting section in this manual.
Green		
Red		•When the green LED is on, the charger is charging at a "FLOAT" rate of less than 1.5 Amps. •This "float" charging current will gradually decrease to as low as 0.1 Amps as the battery reaches 100% charge. It will now be kept at full charge without over-charging. •If the green LED stays on when the battery is known to be low, refer to the troubleshooting section of this manual.
Green		

SPARK PLUG CHECK

Engine spark plugs are an important part of the engine ignition system. Worn or incorrectly adjusted spark plugs can negatively affect engine starting and operation. Therefore, it is important to inspect and regap, or replace the engine spark plugs as indicated in the service interval table. The listed steps are recommended to access and service the engine spark plugs.

⚠ WARNING ⚠



- **Before performing any maintenance, make sure the Mode switch is in the OFF position, the circuit breaker is in the OFF position and the positive (red) battery cable is disconnected.**

1. To gain access to the spark plug on the rear side of the engine, some disassembly of the generator cabinet is required. Begin the disassembly by carefully removing the lid from the enclosure. First remove the ground strap by removing the screw holding it to the lid. Push in the hinge retaining stop (A), then slide the lid (B) to the left to free it from the rest of the enclosure as shown in Fig G. Set the lid aside on a soft surface to avoid scratching the paint.
2. Open the battery access panel by removing the 3 screws and rotating the panel outward (see Fig. E on page 28).
3. Remove the 2 screws (C) fastening the exhaust chamber to the rear engine firewall (see Fig H). Slide the exhaust chamber panel (D) upward to free it from the enclosure and carefully set it aside.
4. Locate and remove the screws (E) retaining the spark plug access cover (F). Remove the cover to gain access to the rear spark plug (G) as shown in Fig H.
5. Remove the enclosure inlet fasteners (H) and front panel (I) as indicated in Fig I to access the front engine spark plug (J).
6. Pull the spark plug boots loose, then clean any dirt from the area around the spark plugs. Remove the spark plugs with a 13/16" spark plug wrench.
7. Inspect the spark plugs for fouling or abnormal wear like excessively worn electrodes or cracked or chipped insulator material. If abnormal wear is indicated, replace the spark plugs. Fouled plugs indicate the need for engine service by a qualified engine service technician.
New spark plugs or plugs that do not display any abnormal characteristics should be checked for proper gap using a suitable spark plug gauge. Adjust the gap to 0.012 - 0.016 inches (0.30 - 0.40 mm) by carefully bending the grounding electrode.
8. Reinstall the spark plugs by hand until they begin to seat to avoid cross-threading. After the plugs begin to seat, tighten used plugs an additional ¼ turn or 13/16" spark plug wrench to avoid damage to the

spark plugs. If a torque wrench is available, tighten all plugs to **13 in-lbs (18 N-m)**.

9. Finish the procedure by reassembling the enclosure front panel (I), spark plug access cover (F), exhaust chamber (D) and enclosure lid (B).

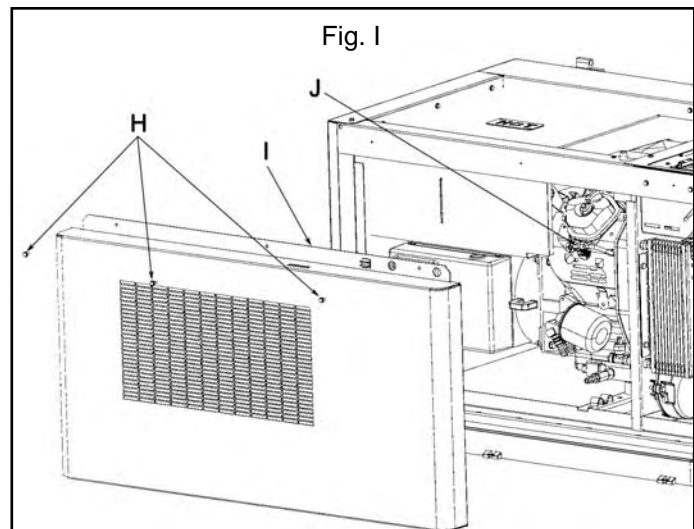
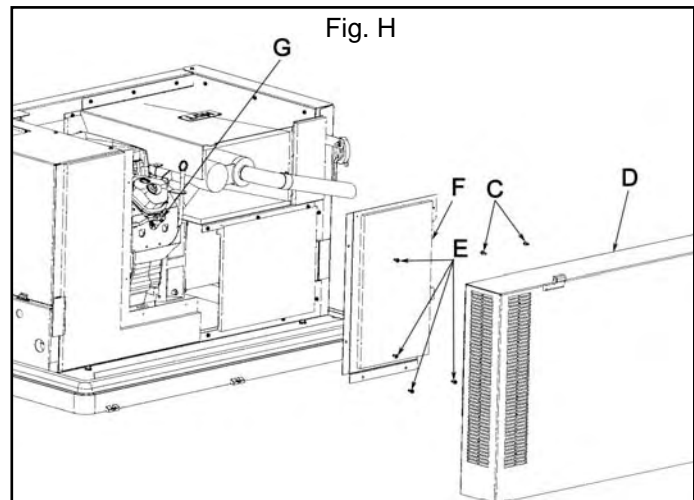
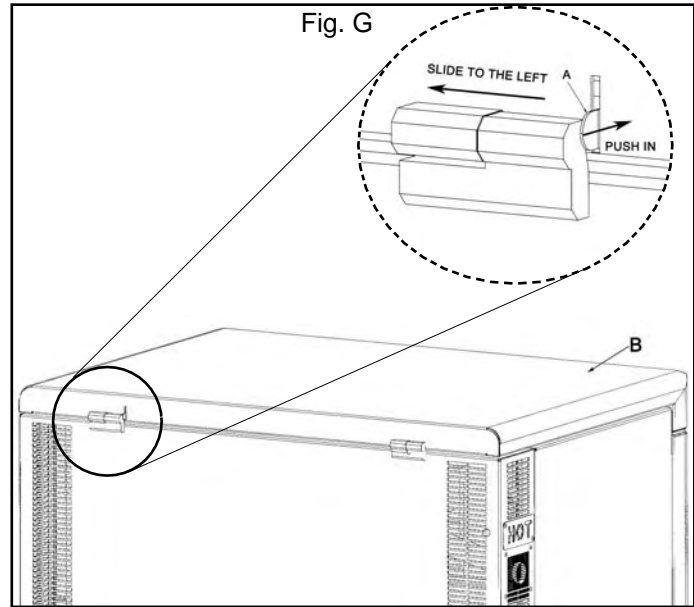

SPARK ARRESTOR CLEANING

In some areas of the United States, a USDA Forest Service approved exhaust spark arrestor is legally required. This optional accessory is added to the generator during initial installation. To identify whether the generator is equipped with a spark arrestor, inspect the exhaust tailpipe opening for a screen. If a screen is present in the tailpipe, the spark arrestor option is installed.

Spark arrestors require periodic inspection and cleaning as indicated in the recommended service interval table on page 25. To maintain the spark arrestor, the following steps are recommended.

1. To gain access to the spark arrestor assembly inside the exhaust chamber, some disassembly of the generator cabinet is required. Begin the disassembly by carefully removing the lid from the enclosure. First push in the hinge retaining stop (**A**), then slide the lid (**B**) to the left to free it from the rest of the enclosure as shown in Fig GG. Set the lid aside on a soft surface to avoid scratching the lid paint.
2. Open the battery access panel by removing the 3 screws and rotating the panel outward (see Fig. E on page 28).
3. Remove the 2 screws (**C**) fastening the exhaust chamber panel (**D**) to the rear engine firewall (see Fig HH). Slide the exhaust chamber panel (**D**) upward to free it from the enclosure and carefully set it aside.
4. Remove the spark arrestor assembly by loosening the screw holding the arrestor to the muffler.
5. Use a low pressure stream of compressed air or water to blow particles from the spark arrestor screen. Ensure that all particles are completely flushed from the tailpipe.
6. Visually inspect the spark arrestor screen to for holes or breaks in the screen. If any are found, replace the spark arrestor assembly.
7. Reinstall the spark arrestor on the muffler outlet and replace the clamp.
8. Slide the exhaust chamber panel (**D**) back into place and install the screws (**C**) holding it to the rear engine firewall.
9. Slide the lid (**B**) back onto the hinges and reinstall the retaining clip to secure the lid place.

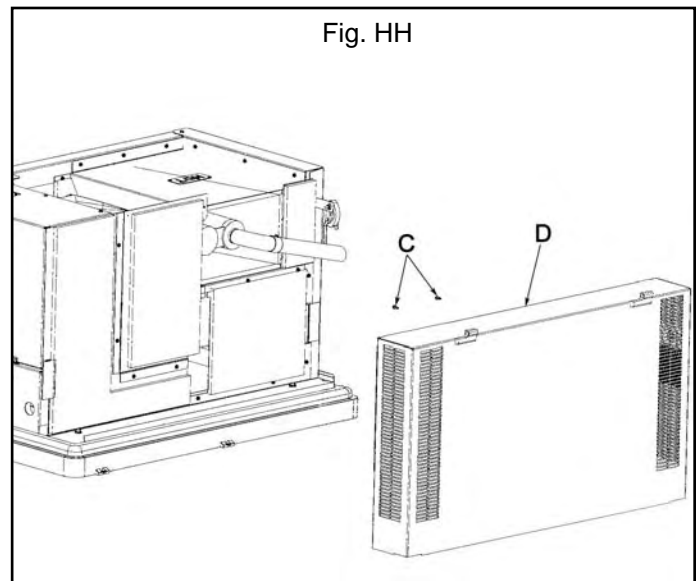
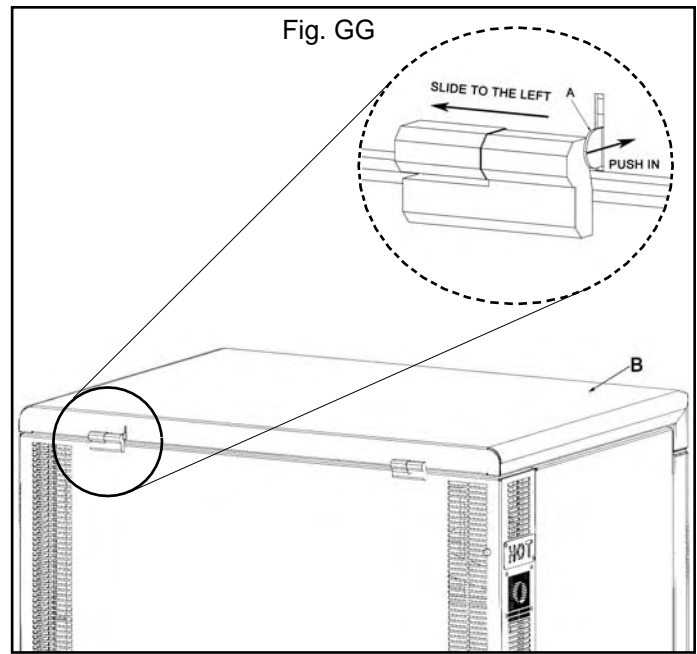

ENCLOSURE AND SITE

Proper cooling of the generator is vital to maintain performance and prevent equipment failure. Blocked cabinet openings or other airflow obstructions are potential fire hazards and can cause failures. Periodically inspect generator cabinet openings and the engine oil cooler for blockages. Do not allow leaves, grass, dirt, snow or other objects to build up around the cabinet. Keep plants and other landscaping groomed to allow a minimum of three (3) feet of open space around all sides of the generator. Do not place a cover over the generator.

⚠ DANGER ⚠



- **Generator exhaust air contains carbon monoxide, a deadly odorless, colorless and tasteless gas. Breathing carbon monoxide causes severe nausea, fainting or death. Do not allow exhaust air to enter a building through windows, doors, air intakes or other means. Avoid breathing exhaust air while operating or servicing the generator set. The engine exhaust from this product contains chemicals known to the State of California to cause cancer, birth defects, or other reproductive harm.**

⚠ CAUTION ⚠

- **Covering or restricting the air passages on the generator will cause the unit to overheat and may create a fire hazard. Do not allow snow or leaves to cover enclosure openings.**
- **Leave a three foot open area around all sides of the unit. Do not plant trees or plants which may grow within three feet of the unit.**
- **Unit should be located to prevent combustible material from accumulating against the generator.**
- **The generator MUST be installed outdoors.**

GOVERNOR SPEED ADJUSTMENT

The engine governor is set at the factory to maintain generator output frequency within specifications and is readjusted if required during installation. However, engine wear may cause frequency to vary as the generator accumulates hours. Periodic checking and adjustment of generator frequency by a qualified generator technician is recommended as outlined in the table on page 25. If speed adjustment is necessary, follow the listed procedure to set the correct engine speed.

⚠ CAUTION ⚠

- **This adjustment should only be performed by trained personnel. If incorrect adjustments are made, the unit may fail to operate or operate inefficiently.**

1. Start the engine by moving the control panel Mode switch to the RUN position and let the generator run for a minimum of five minutes with no electrical loads connected.
2. Once the generator is warmed up, check the generator output frequency with a suitable meter. Normal unloaded frequency is approximately 62.5 Hz.
3. Adjust engine speed to 62.5 as required by turning the engine governor screw, shown in Fig K. Turn the screw clockwise to increase frequency and counterclockwise to decrease frequency.
4. Turn the engine off by moving the control panel Mode switch back to the OFF position.

Fig. K

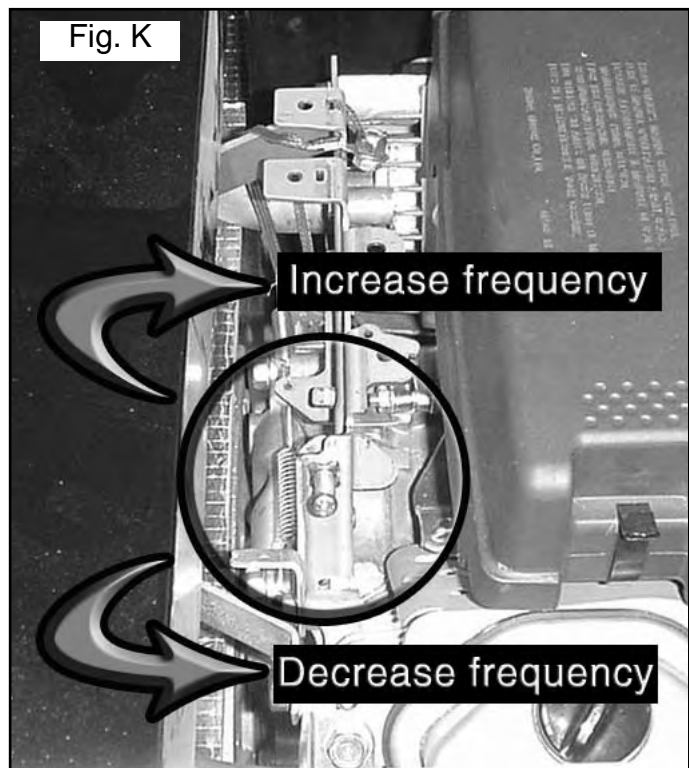

VALVE CLEARANCE CHECK AND ADJUSTMENT

Over time, normal engine operation leads to wear in the engine valve train which decreases generator output. To restore generator output, it is necessary to check and adjust the engine valve lash at regular intervals throughout the life of the engine. However, proper valve lash adjustments require specialized training and tools. Adjustment by persons unfamiliar with the procedure can cause damage to the engine not covered under warranty. Contact an authorized generator dealer for assistance in locating qualified service personnel.

CAUTION

- **This adjustment should only be performed by trained personnel. If incorrect adjustments are made, the unit may fail to operate or operate inefficiently.**

FUEL SYSTEM INSPECTION

Avoid explosive and potentially lethal fuel leaks by inspecting the complete generator fuel supply system at intervals no greater than those listed in the Maintenance Table on page 25. Visually inspect all hoses for cracks, splits, or brittleness and replace hoses that show these or other signs of wear. Check all connections for tightness and cracks, replacing any broken fittings or clamps. Check all connections for leaks, while the generator is running, using approved equipment and methods. DO NOT use a flame to check for leaks.

WARNING



- **Extreme caution should be taken while performing general maintenance.**
- **Do not smoke when near the unit.**
- **Keep flames, sparks, pilot lights, arc-producing equipment, switches and all other sources of ignition well away. Keep a type ABC fire extinguisher handy.**
- **Do Not operate engine if smell of fuel is present or other explosive conditions exist.**
- **Do Not use a flame to check for leaks.**

TROUBLESHOOTING

SYMPTOM	POSSIBLE CAUSE	CORRECTIVE ACTION
Engine does not crank	Loose battery cables	<ul style="list-style-type: none"> • Check all battery cable connections
	Defective battery	<ul style="list-style-type: none"> • Test battery. Replace as necessary. • Check battery charger inline fuse
	Improper battery charger function	<ul style="list-style-type: none"> • Ensure charger is plugged into GFCI receptacle • Check for tripped GFCI receptacle. Reset if required. • Check for tripped breaker in branch circuit supplying GFCI. Reset if required. • Check all charger cable connections for cleanness and tightness. • Check charger lights to verify correct operation. See Table A, Page 29.
		Fault in starter signal circuit
Engine cranks without starting	Blown control circuit fuse	<ul style="list-style-type: none"> • Check control circuit fuse.
	Low battery	<ul style="list-style-type: none"> • Test battery. Replace as necessary. • Ensure charger is plugged into GFCI receptacle • Check for tripped GFCI receptacle. Reset if required. • Check for tripped breaker in branch circuit supplying GFCI. Reset if required. • Check all charger cable connections for cleanness and tightness. • Check charger lights to verify correct operation. See Table A, Page 29.
		Poor fuel supply
Engine starts then immediately shuts down	Low oil pressure	<ul style="list-style-type: none"> • Check engine oil level • Check switch for proper function
	High engine temperature	<ul style="list-style-type: none"> • Allow engine to cool, then restart • Decrease loads on generator • Check enclosure openings for blockage • Check oil cooler for blockage
No generator output	Main line circuit breaker tripped	<ul style="list-style-type: none"> • Check breaker. Clear faults, then reclose breaker.
	Disconnect breaker tripped	<ul style="list-style-type: none"> • Check for tripped breaker in circuit between generator output and transfer switch. Clear fault, then reclose breaker.
	Generator loss of excitation	<ul style="list-style-type: none"> • Contact a qualified generator dealer for service assistance.
	Excitation capacitor failure	<ul style="list-style-type: none"> • Contact a qualified generator dealer for service assistance.
	Generator diode or varistor failure	<ul style="list-style-type: none"> • Contact a qualified generator dealer for service assistance.
	Generator head fault	<ul style="list-style-type: none"> • Contact a qualified generator dealer for service assistance.

TROUBLESHOOTING

SYMPTOM	POSSIBLE CAUSE	CORRECTIVE ACTION
Low generator output voltage	Low engine speed	<ul style="list-style-type: none"> • Verify correct engine speed. Remove excess loads or adjust speed as required.
	Excitation capacitor failure	<ul style="list-style-type: none"> • Contact a qualified generator dealer for service assistance.
	Generator diode or varistor failure	<ul style="list-style-type: none"> • Contact a qualified generator dealer for service assistance.
Overspeed light stays lit	Shutdown due to high engine speed	<ul style="list-style-type: none"> • Verify correct engine speed setting. Adjust engine speed as required.
Underspeed light stays lit	Shutdown due to low engine speed	<ul style="list-style-type: none"> • Reduce loads connected to generator
Overcrank light stays lit	Failure to start	<ul style="list-style-type: none"> • Check engine speed setting at no load. Adjust as required.
Not In Auto light stays lit	Generator not set for unattended operation	<ul style="list-style-type: none"> • See "Engine cranks without starting" • Place mode switch into AUTO position if automatic function is required
Low oil pressure light stays lit	Shutdown due to low engine oil pressure	<ul style="list-style-type: none"> • Check engine oil level.
Low battery light stays lit	Low battery	<ul style="list-style-type: none"> • Verify correct type of engine oil for ambient temperature conditions
		<ul style="list-style-type: none"> • Test battery. Replace as necessary.
		<ul style="list-style-type: none"> • Ensure charger is plugged into GFCI receptacle
		<ul style="list-style-type: none"> • Check for tripped GFCI receptacle. Reset if required.
		<ul style="list-style-type: none"> • Check for tripped breaker in branch circuit supplying GFCI. Reset if required.
		<ul style="list-style-type: none"> • Check all charger cable connections for cleanliness and tightness.
		<ul style="list-style-type: none"> • Check battery charger inline fuse • Check charger lights to verify correct operation. See Table A, Page 29.
High engine temperature light stays lit	Blown charger circuit fuse	<ul style="list-style-type: none"> • Check engine alternator fuse
	Shutdown due to high engine temperature	<ul style="list-style-type: none"> • Allow engine to cool, then restart
		<ul style="list-style-type: none"> • Decrease loads on generator • Check enclosure openings for blockage • Check oil cooler for blockage

PARTS DRAWING - EXHAUST SYSTEM

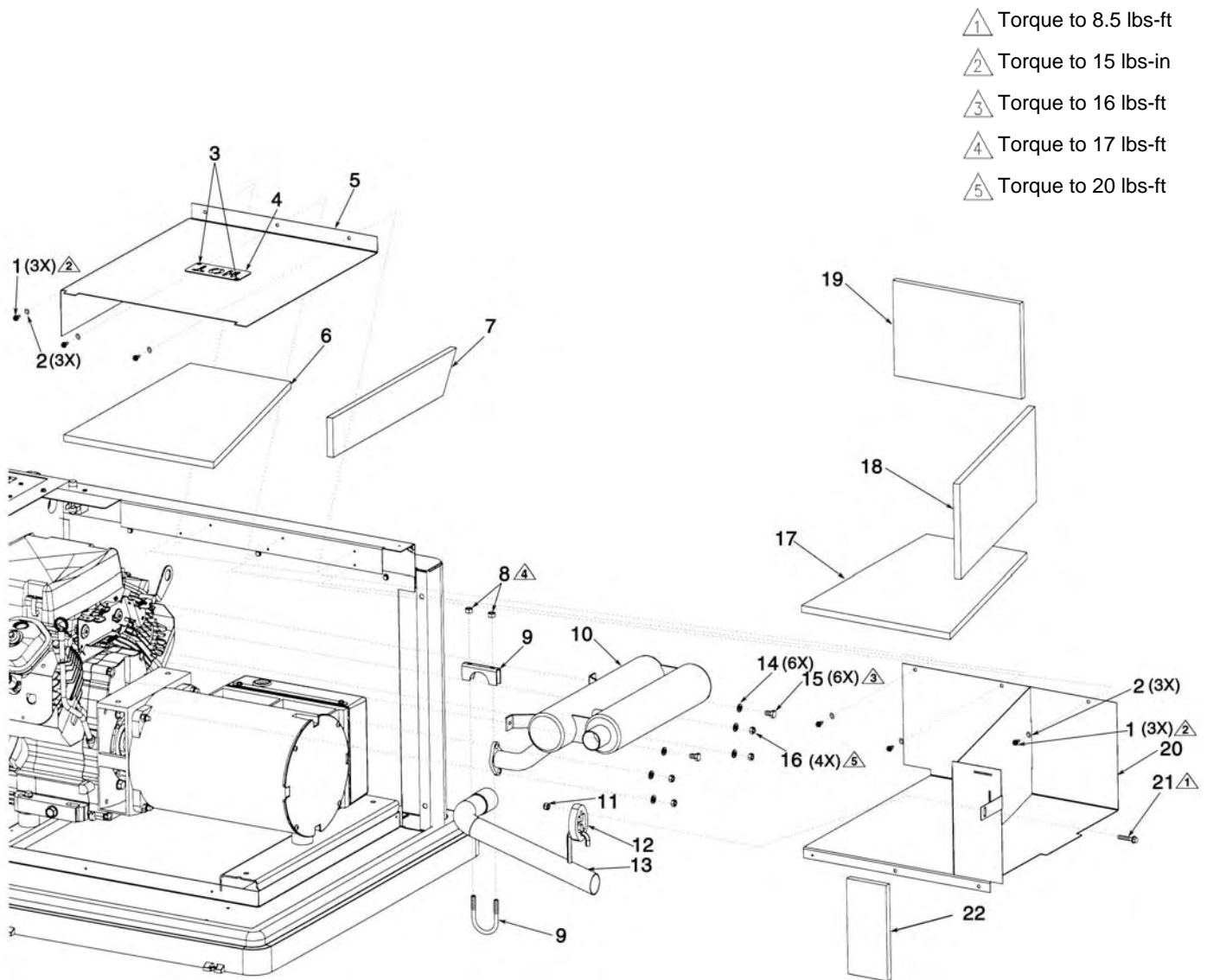

PARTS LIST

Item	Part No	Qty	Description	Item	Part No	Qty	Description
1	N/A	9	Screw, 10-16 x .50" lg	15	N/A	2	Screw, m8 x 13 mm lg
2	N/A	9	Star washer, #10	16	N/A	4	Nut (see Honda manual)
3	N/A	2	Rivet	17	094-0070	1	Insulation
4	Not replaceable	1	Label, hot, stamped steel	18	094-0072	1	Insulation
5	115-0262	1	Cover, muffler (includes items 3, 4, 6 & 7)	19	094-0071	1	Insulation
6	094-0069	1	Insulation	20	115-0263	1	Muffler box (includes items 17, 18, 19 & 22)
7	094-0073	1	Insulation	21	N/A	1	Bolt, 1/4-20 x 1.25" lg
8	N/A	2	Nut, 5/16-18	22	094-0094	1	Insulation
9	0056767	1	Clamp, saddle (includes (2) item #8)	*N/A - These are standard parts available at your local hardware store.			
10	019-0214	1	Exhaust manifold muffler, Honda				
11	N/A	1	Nut, 1/4-20, Nylon stop				
12	094-0093	1	Isolator, muffler bracket to panel				
13	145-0418	1	Tail pipe				
14	N/A	6	Lock washer, 5/16"				

PARTS DRAWING - ENCLOSURE

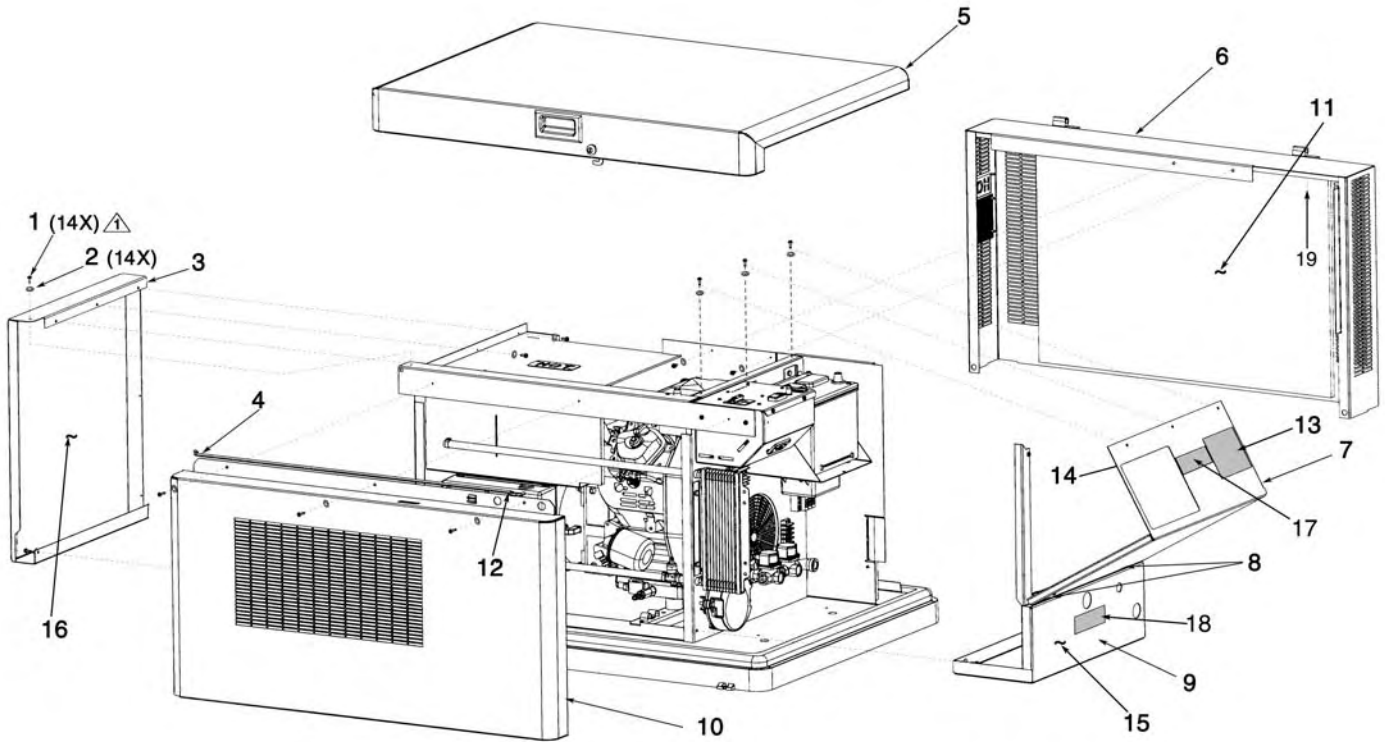

⚠ Torque to 15 lbs-in



PARTS LIST

Item	Part No	Qty	Description	Item	Part No	Qty	Description
1	N/A	14	Screw, 10-16 x .50" lg	12	103-0121	1	Clip, hood rod
2	N/A	14	Star washer, #10	13	098-2758	1	Warning label
3	115-0264	1	Side panel, left side (includes item 16)	14	094-0084	1	Insulation (not shown)
4	S115-0242	1	Prop arm, lid	15	094-0076	1	Insulation (not shown)
5	S115-0240	1	Lid assembly, complete (see page 38 for separate parts)	16	094-0083	1	Insulation (not shown)
6	115-0265	1	Panel, back (includes items 11 & 19)	17	098-2856	1	Warning label
7	115-0266	1	Access panel, top portion (includes items 13, 14 & 17)	18	098-2759	1	Fuel label
8	107-0061	2	Hinge, swivel	19	094-0078	1	Insulation, exhaust top (not shown)
9	115-0267	1	Access panel, bottom portion (includes item 15 & 18)	Not shown	094-0108	1	Weather seal (3/16" h x 1/2" w x 12' lg)
10	S115-0218	1	Door assembly, (includes inner door panel)	Not shown	094-0107	1	Weather seal (1/8" h x 1/2" w x 12' lg)
11	094-0075	1	Insulation (not shown)	*N/A - These are standard parts available at your local hardware store.			

PARTS DRAWING - LID ASSEMBLY

-  Torque to 7 lbs-ft
-  Torque to 15-20 lbs-in
-  Torque to 24 lbs-in

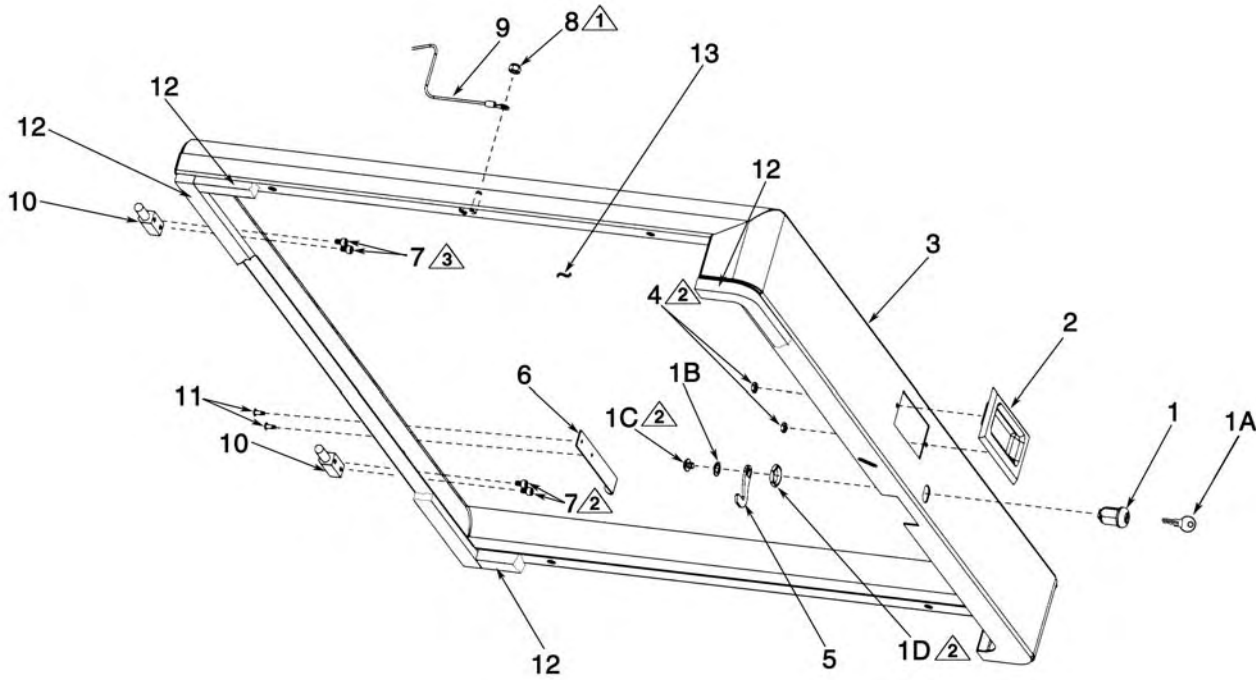

PARTS LIST

Item	Part No	Qty	Description	Item	Part No	Qty	Description
1	0056765	1	Lock (includes 1A, 1B, 1C & 1D)	9	026-0535	1	Ground strap, 17" lg
1A	146-0023	1	Key	10	107-0062	2	Hinge (includes (4) item #7)
1B	Order item # 1	1	Washer	11	N/A	2	Rivet
1C	Order item #1	1	Bolt	12	094-0106	1	Weather seal (1/4 h x 3/4 w x 12' lg)
1D	Order item #1	1	Nut	13	094-0077	1	Insulation
2	0056761	1	Handle	--	S115-0240	1	Lid assembly, complete (includes all of the items listed above)
3	S115-0251	1	Lid weldment (order S115-0240 for complete lid assembly)	*N/A-	These are standard parts available at your local hardware store.		
4	N/A	2	Nut, 10-32				
5	0056766	1	Lock, hooked pawl				
6	114-0571	1	Bracket, lid stop				
7	0058221	4	Screw, M5-.8 x 8MM				
8	N/A	2	Nut, 1/4-20 Nylon stop				

PARTS DRAWING - GENERATOR

⚠ Torque to 15 lbs-ft

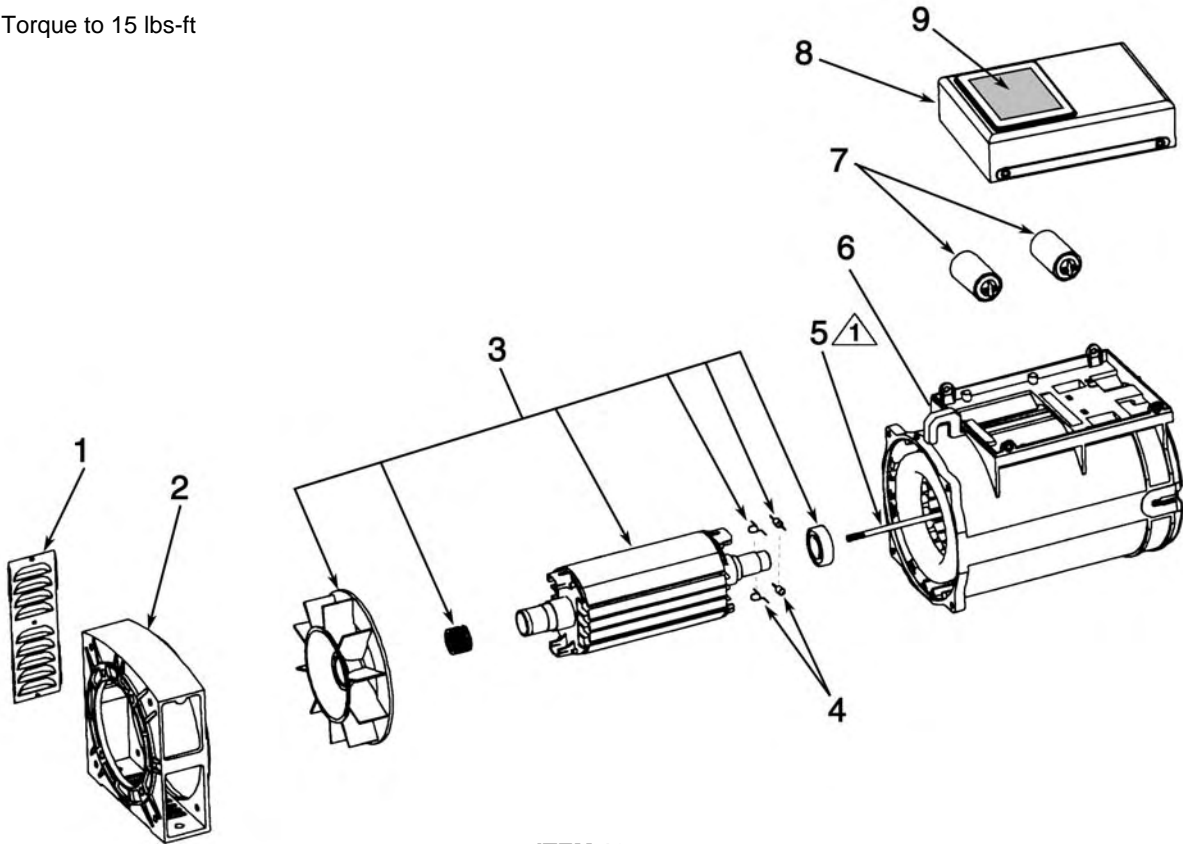

ITEM 10

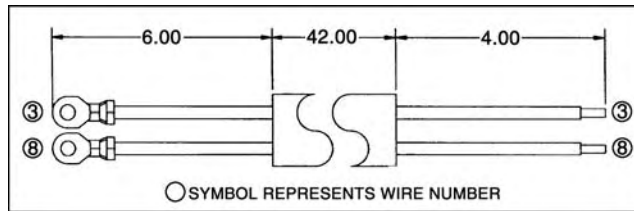

ITEM 11

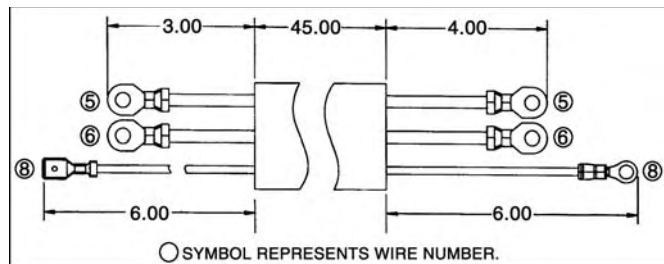

PARTS LIST

Item	Part No	Qty	Description	Item	Part No	Qty	Description
1	0056629	1	Discharge louvered cover	10	026-0515	1	Wiring harness, generator neutral
2	0056623	1	Engine adapter	11	026-0514	1	Wiring harness, generator power
3	160-0311	1	Rotor assembly	--	160-0309	1	Complete generator assembly
4	100-0003	2	Diode/varistor assembly				
5	059-0348	1	Rotor bolt				
6	160-0312	1	Stator assembly				
7	166-0133	2	Capacitor, 40F, 500V				
8	077-0168	1	Terminal box cover				
9	098-2827	1	Warning label				

PARTS DRAWING -H2X BREAKDOWN

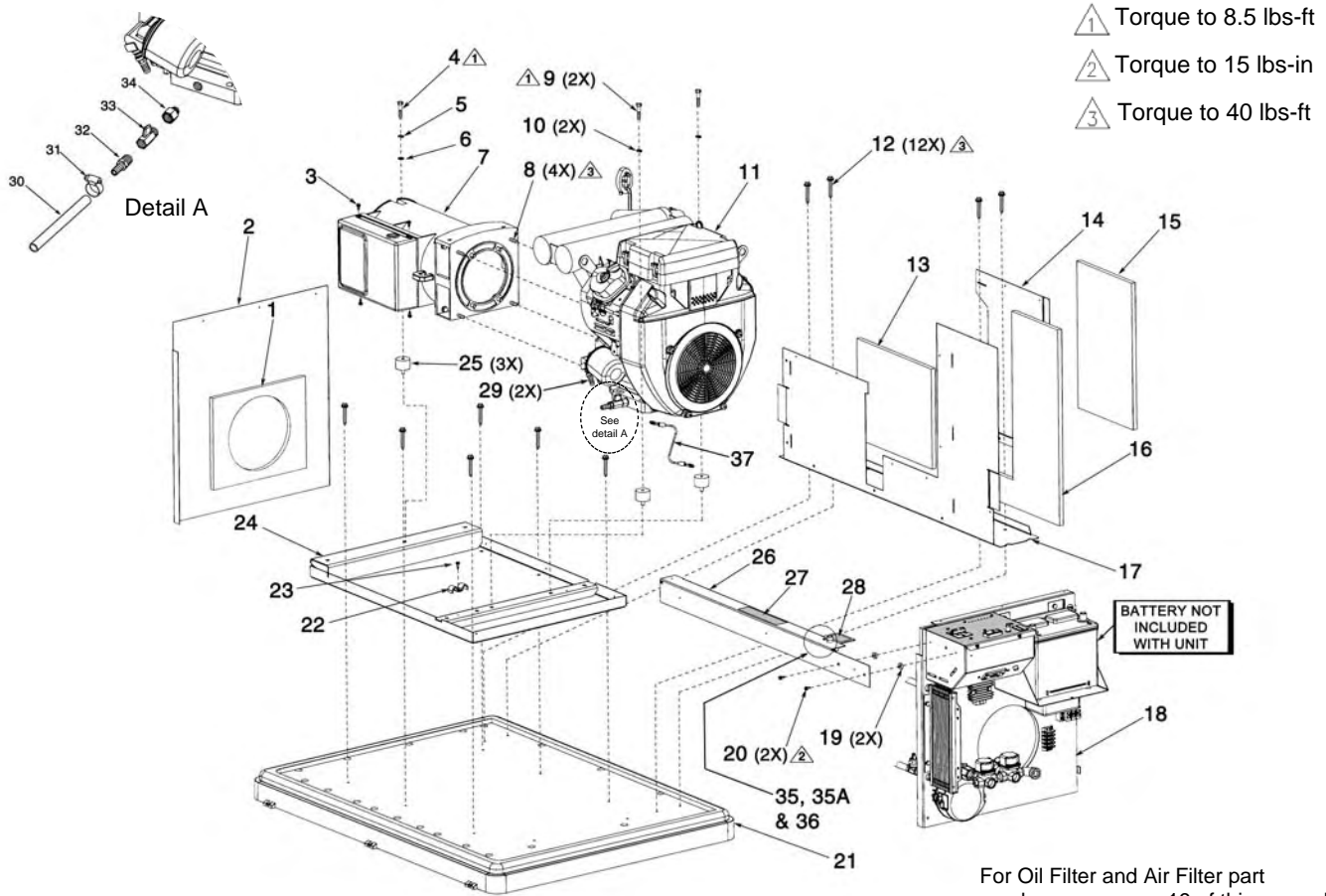

PARTS LIST

Item	Part No	Qty	Description	Item	Part No	Qty	Description
1	094-0091	1	Insulation	21	109-0100	1	Base, plastic
2	115-0268	1	Panel, left side (includes item 1)	22	071-0031	1	Hose clamp
3	N/A	4	Screw, 10-32 x .50" lg	23	N/A	1	Screw, 10-14 x .63" lg
4	N/A	1	Bolt, 5/16 NC x 1.25" lg	24	S108-0160	1	Engine pan
5	N/A	1	Lock washer, 5/16"	25	094-0068	3	Vibration isolator
6	N/A	1	Washer, 5/16"	26	115-0271	1	Crossbrace assembly (includes items 27, 28, 35, 35A & 36)
7	160-0309	1	Generator assembly	27	098-2828	1	Warning label
8	N/A	4	Bolt, 3/8-16 x .75" lg	28	098-2821	1	Warning label
9	N/A	2	Bolt, 5/16 NC x 1.50" lg	29	068-0084	1	Fitting, hose barb 1/8 x 3/8
10	N/A	2	Lock washer, 5/16"	30	012-0094	1	Hose, oil drain
11	025-0063	1	Engine, Honda, GX620 (muffler ... not incl. - see page 36 for details)	31	012-0098	1	Hose clamp, .50-1.2
or	025-0059	1	Engine, Honda, GX670 (muffler ... not incl. - see page 36 for details)	32	0057747	1	Fitting, barb 3/8 x 1/2
12	N/A	12	Lag screw, 5/16 x 2" lg w/washer	33	0057746	1	Valve ball, 3/8 M/F
13	094-0074	1	Insulation	34	063-0042	1	Adapter, oil drain
14	115-0269	1	Exhaust access panel (includes item 15)	35	026-0309	1	Fuse holder
15	094-0081	1	Insulation	35A	026-0518	1	Fuse, type 3AG, 25 Amp 32V
16	094-0080	1	Insulation	36	026-0547	1	Relay DC, 12V, COIL
17	115-0270	1	Back panel (includes items 13 & 16)	37	S0049224	1	Ground strap, 12GA, 5.50" lg
18	115-0245	1	Engine panel assembly (see pages 41, 42 & 43 for details)				
19	094-0095	2	Spacer				
20	N/A	2	Screw, #10 x 1/2" sheet metal				
				*N/A -	These are standard parts available at your local hardware store.		

PARTS DRAWING - ENGINE PANEL END ASSEMBLY

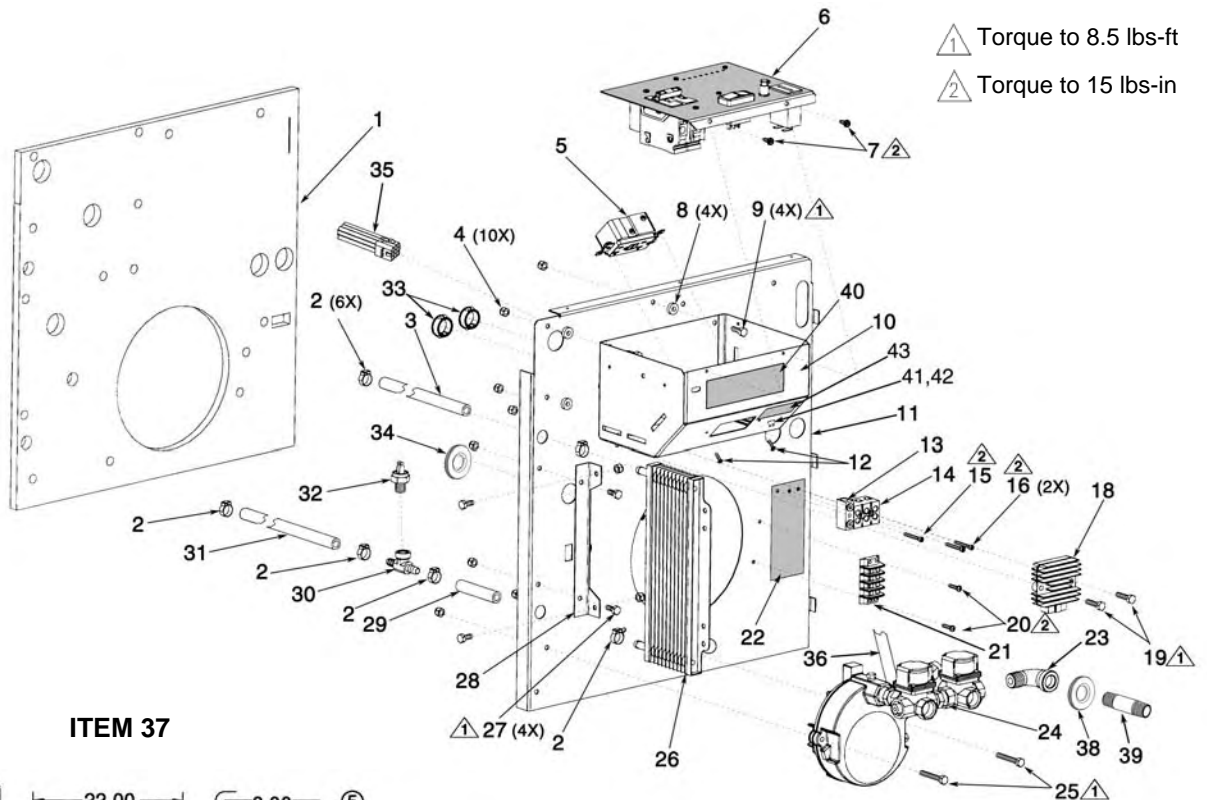

ITEM 37

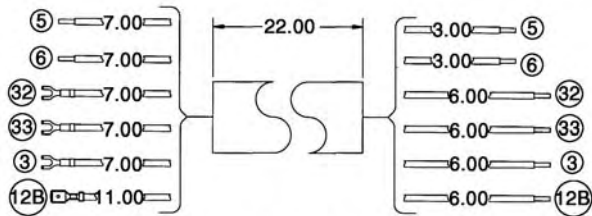

○ SYMBOL REPRESENTS WIRE NUMBER.

NOTE: Seal all connections with gas tape. Use 2½ wraps minimum. Check all connections under pressure using a soap and water solution.

PARTS LIST

Item	Part No	Qty	Description	Item	Part No	Qty	Description
1	094-0096	1	Insulation	24	019-0211	1	Regulator assy, GX670 (PM401211)
2	N/A	6	Hose clamp, 23/32" I.D.	or	019-0213	1	Regulator assy, GX620 (PM400911)
3	S012-0106	1	Hose, high temp oil, 3/8" x 26.5" lg	25	N/A	2	Bolt, 1/4-20 x 1.75" lg
4	N/A	10	Nut, 1/4-20, Nylon stop	26	0057079	1	Oil cooler
5	026-0338	1	GFCI Receptacle	27	N/A	4	Bolt, 1/4-20 x .63" lg
6	See page 42	1	Control panel assy, CP200	28	S114-0564	1	Bracket, oil cooler
7	N/A	2	Screw, 10-16 x .50" lg	29	Order S012-0106	1	Hose, high temp oil, 3/8" x 3" lg
8	094-0095	4	Spacer, .75 O.D.	30	069-0022	1	Tee, adapter oil temp
9	N/A	4	Screw, 1/4-20 x .75" lg	31	Order S012-0106	1	Hose, high temp oil, 3/8" x 13" lg
10	S115-0238	1	Control box frame	32	034-0162	1	Switch, oil temp
11	115-0272	1	Panel, right hand (includes items 1 & 22)	33	051-0091	2	Bushing, snap .875 ID
12	N/A	2	Screw, 6-32 x .50" lg	34	093-0053	1	Rubber grommet
13	026-0460	1	Terminal block, ground lug	35	026-0512	1	Wire harness, engine control
14	026-0472	1	Terminal block	36	012-0120	1	Vapor hose assembly
15	N/A	1	Screw, torx 8-32 x 1.25" lg	37	026-0516	1	Wire harness, terminal block power
16	N/A	2	Screw, 8-32 x 1.25" lg	38	093-0054	1	Fuel grommet, .84 ID x 1.875 OD
17	N/A	5	Nut, #8-32 (not shown - for items 15, 16 and 20)	39	N/A	1	Nipple, 3" lg, 1/2 NPT
18	N/A	1	Rectifier shipped with engine (Contact Honda Service Center)	40	098-2826	1	Warning label
19	N/A	2	Bolt, 1/4-20 x 1	41	026-0309	1	Fuse holder
20	N/A	1	Screw, 8-32 x .75" lg	42	N/A	1	Fuse, 5A Type 3AG
21	026-0539	1	Terminal block, 2 row 20A 4-pole	43	098-2850	1	Fuse label
22	098-2800	1	Warning label				
23	N/A	1	Elbow, 1/2 NPT x 1/2 NPT				
				*N/A -	These are standard parts available at your local hardware store.		

PARTS DRAWING - CONTROL PANEL BREAKDOWN

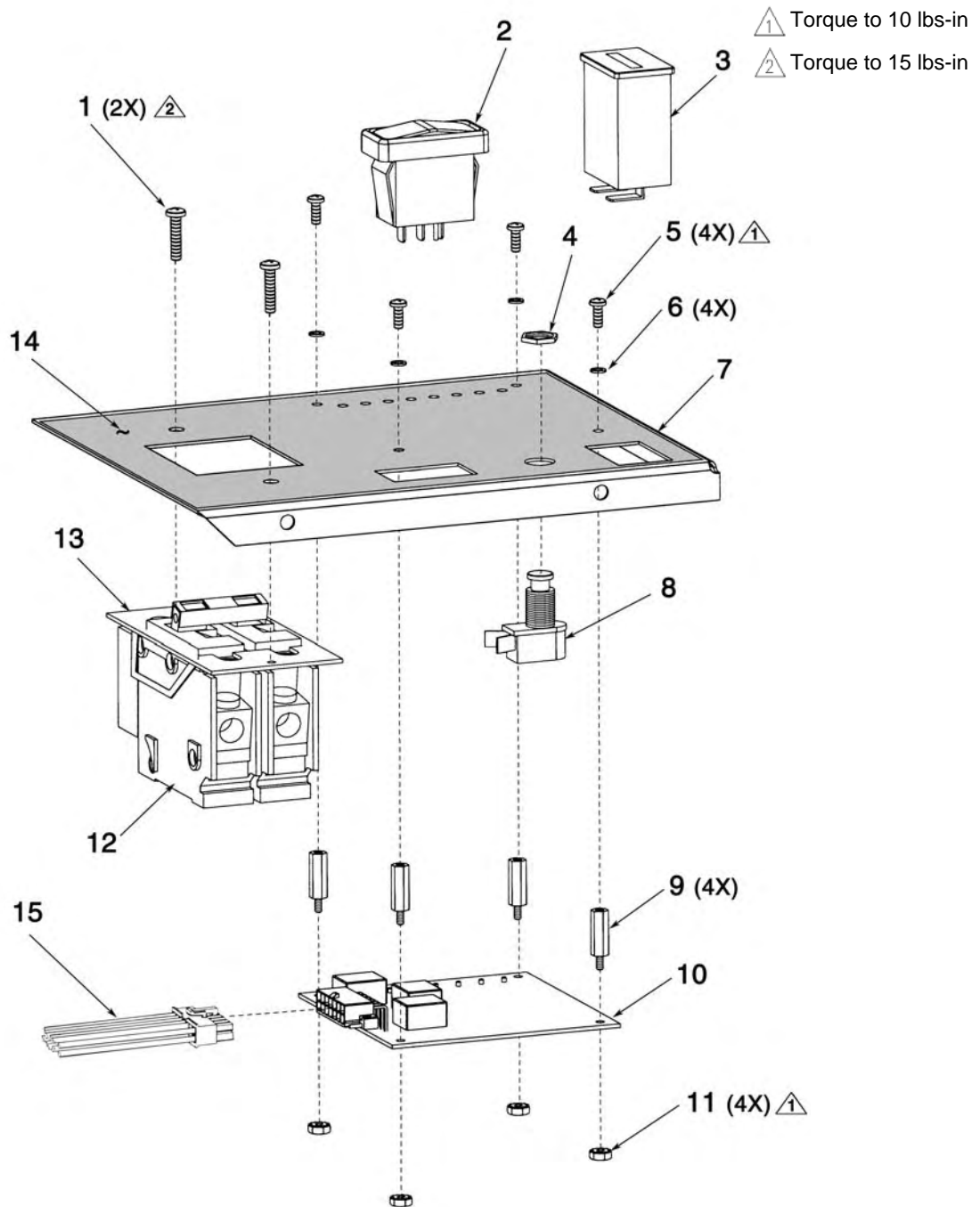

PARTS LIST

Item	Part No	Qty	Description	Item	Part No	Qty	Description
1	N/A	2	Screw #8-32 x .75 phillips hd	12	002-0060	1	Circuit breaker, 50 Amp, 120/240V (PM401211)
2	034-0161	1	Switch, toggle	or	002-0061	1	Circuit breaker, 45 Amp, 120/240V (PM400911)
3	032-0067	1	Hourmeter, 120V AC 60HZ	13	0058069	1	Circuit breaker mount
4	(see #8)	1	Not available separately	14	098-2820	1	Control panel label, CP200
5	N/A	4	Screw, 6-32 x .38"lg	15	026-0537	1	Wire harness
6	N/A	4	Lock washer #6				
7	115-0273	1	Control box top (includes item 14)				
8	0056884	1	Switch, momentary				
9	060-0175	4	Standoff, 6-32 x .75"lg				
10	026-0534	1	Controller board, CP200				
11	N/A	4	Nut #6-32, Nylon stop				

*N/A - These are standard parts available at your local hardware store.

PARTS DRAWING - BATTERY HOLD DOWN

- △1 Torque to 7 lbs-ft
- △2 Torque to 8.5 lbs-ft

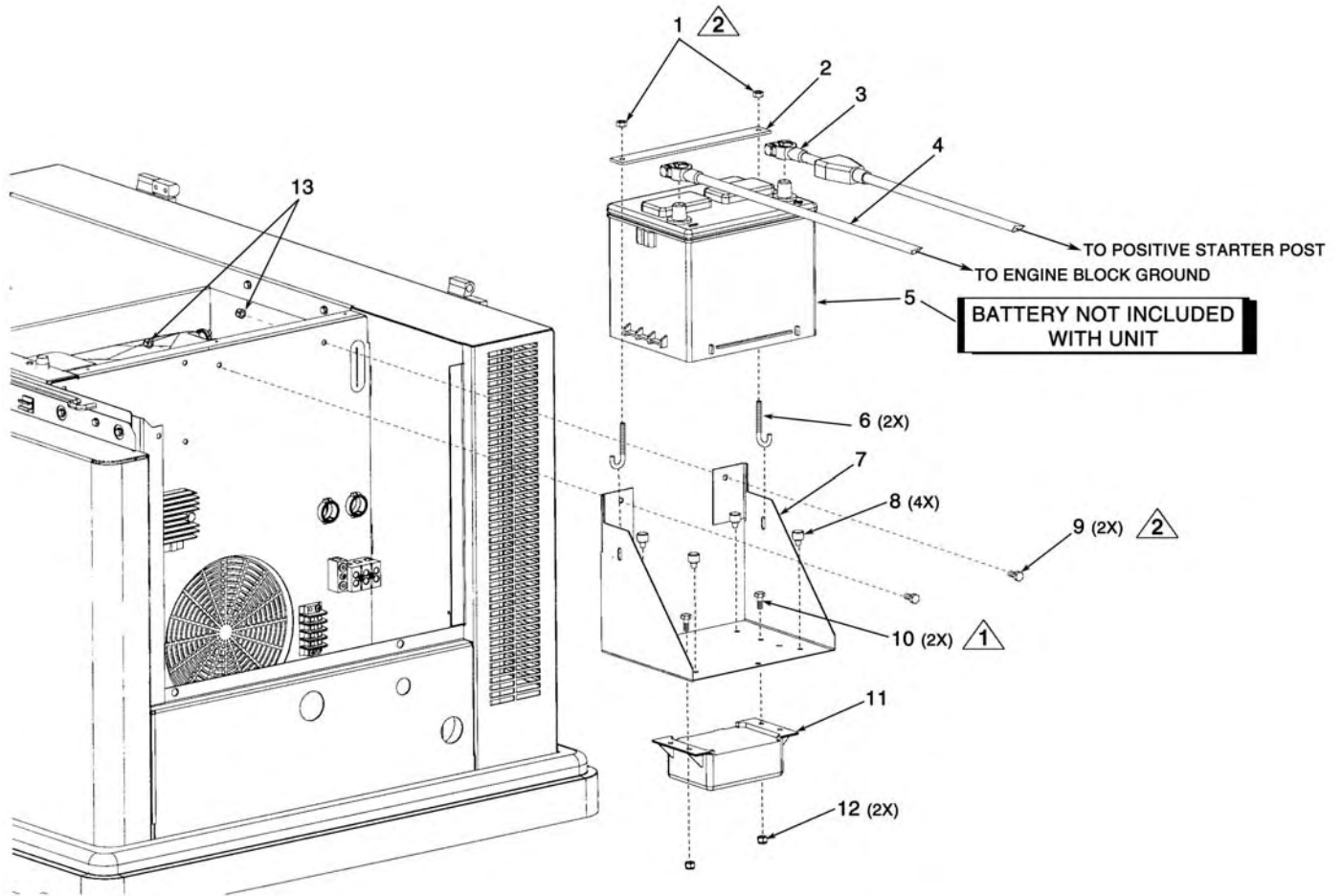

PARTS LIST

Item	Part No	Qty	Description
1	N/A	2	Nut, 1/4-20
2	S114-0563	1	Bracket, battery hold down
3	026-0480	1	Battery cable, positive
4	026-0481	1	Battery cable, negative
5	N/A	1	Battery, BCI Group 26 or 26R
6	059-0344	2	J-bolt, 1/4-20
7	S115-0229	1	Battery shelf
8	0057024	4	Battery standoff, rubber
9	N/A	2	Bolt, 1/4-20 x .625" lg
10	N/A	2	Screw, 1/4-20 x 1" lg
11	026-0696	1	Battery charger
11A	N/A	1	Fuse, type 3AG, 25 Amp, 32V
12	N/A	2	Nut, nylon stop 1/4-20
13	N/A	2	Nut, 1/4-20 nyloc

*N/A - These are standard parts available at your local hardware store.

Coleman PowerStation™ Stationary Standby 3-Year or 1500 Hour Limited Warranty

Your Coleman PowerStation™ emergency back up power system generator has been manufactured to stringent guidelines & standards for years of dependable operation & service. Coleman Powermate warrants this product to the original consumer against defects in material and workmanship for a period of 3-Years or 1500 hours, whichever occurs first, from the date of purchase and is not transferable.

Coverage:

Replacement parts & labor, including travel time & mileage, for defects in product found to be properly installed, maintained & operated in accordance with Coleman Powermate & supplied component operator's manuals are eligible for warranty coverage. A Coleman Powermate Authorized Master Representative, their dealer or their agent must perform warranty service. Items not covered under the warranty are:

- ⦿ Normal engine wear, tune-ups, and routine service.
- ⦿ Damage caused by shipping, accidents, improper installation or handling, improper storage, or repairs not performed by a Coleman Powermate authorized Master Representative, their dealer or their agent.
- ⦿ Damage caused by operation with improper fuel or at speeds, loads, conditions, modifications, or installation contrary to published specifications or recommendations.
- ⦿ Damage caused by negligent maintenance such as:
 - Failing to provide the specified type and sufficient quantity of lubricating oil.
 - Failing to keep the air intake and cooling areas clean.
 - Failing to service the air cleaner.
 - Failing to provide sufficient coolant.
 - Failing to perform scheduled maintenance as recommended by Coleman Powermate or by supplied component manufacturers.
 - Failing to regularly exercise the generator set.
- ⦿ Original installation charges and startup costs.
- ⦿ Starting batteries, travel & labor associated with battery failure.
- ⦿ Rental of equipment during performance of warranty repairs.
- ⦿ Engines, or other components, which are covered exclusively by the warranty of their manufacturer.
- ⦿ Altered, tampered or improperly maintained emission control system components.
- ⦿ Parts purchased for a replacement of a failed Coleman Powermate part with a non-Coleman Powermate part voids warranty on that part.
- ⦿ Fuel injection pumps not repaired locally by an authorized servicing dealer.
- ⦿ Non-Coleman Powermate-authorized repair shop labor without prior approval from Coleman Powermate Warranty Department.
- ⦿ Engine fluids such as fuel, oil, or coolant/antifreeze.
- ⦿ Expenses incurred investigating performance complaints unless defective Coleman Powermate materials or workmanship is the cause of the problem.
- ⦿ Maintenance items such as fuses lamps, filters, spark plugs and adjustments.
- ⦿ Sales outside the U.S. or Canada
- ⦿ Telephone charges or transportation charges in connection with the repair of defective parts.
- ⦿ Overtime labor charges incurred at the request of owner unless prior approval is obtained by Coleman Powermate.
- ⦿ Air freight charges or shipping charges outside of Coleman Powermate shipping practices
- ⦿ Any other expense including consequential damages, incidental damages, or incidental expenses, including damage to property. Some states do not allow the exclusion or limitation of incidental damages, so the limitation may not apply to you.

Implied Warranties:

Any implied warranties, including the Implied Warranties of Merchantability and Fitness For A Particular Purpose, are limited in duration to 3-Years or 1500 Hours from the date of consumer purchase. Some states do not allow limitations on how long an implied warranty lasts, so the limitation may or may not apply to you.

How To Obtain Warranty Performance:

Replacement parts & service are available from Coleman Powermate's Master Representative service network. Locate the nearest service location by calling 1-800-445-1805, or write: Coleman Powermate Inc., 4970 Airport Road, PO Box 6001, Kearney NE 68848.

To the extent any provision of this warranty is prohibited by federal, state, or municipal law, and cannot be preempted, it shall not be applicable. This warranty gives you specific rights, and you may have other rights which may vary from state to state.



**CONTACT THE COLEMAN POWERMATE PRODUCT SERVICE DEPARTMENT AT
1-800-445-1805**

to obtain warranty service information or to order replacement parts or accessories.

HOW TO ORDER REPLACEMENT PARTS

Even quality built equipment such as the Coleman Powermate standby generator you have purchased, might need occasional replacement parts to maintain it in good condition over the years. To order replacement parts, please give the following information:

1. Model No. and Serial No. and all specifications shown on the Model No./Serial No. plate.
2. A brief description of the trouble with the generator.

APPELER LE SERVICE DES PRODUITS COLEMAN POWERMATE AU 1-800-445-1805 pour obtenir des informations sur le service de garantie ou pour commander des pièces ou des accessoires.

COMMENT COMMANDER DES PIÈCES DE RECHANGE

Même l'équipement de première qualité, comme la génératrice de réserve Coleman Powermate que vous avez achetée, peut nécessiter occasionnellement des pièces de rechange pour demeurer en parfait état de marche au fil des années. Pour commander des pièces, veuillez indiquer les renseignements suivants :

1. Le n° de modèle et le n° de série ainsi que toutes spécifications figurant sur la plaque signalétique des numéros de modèle et de série.
2. Une brève description du problème de la génératrice.

COMUNÍQUESE CON EL DEPARTAMENTO DE SERVICIO DE PRODUCTOS COLEMAN POWERMATE EN EL TELÉFONO

1-800-445-1805

para obtener información sobre servicios de garantía o para pedir piezas de repuesto o accesorios.

CÓMO PEDIR PIEZAS DE REPUESTO

Incluso los equipos de calidad como el generador de emergencia Coleman Powermate que ha comprado necesitan ocasionalmente piezas de repuesto para mantenerlos en buenas condiciones a través de los años. Para pedir piezas de repuesto, sírvase entregar la información siguiente:

1. N.º de modelo y de serie y todas las especificaciones que se muestran en la placa de N.º de Modelo/N.º de Serie.
2. Una descripción breve del problema con el generador.

**Coleman Powermate, Inc.
4970 Airport Road
P. O. Box 6001
Kearney, NE 68848
1-800-445-1805
1-308-237-2181
Fax 1-308-234-4187**

