



**OWNERS MANUAL**  
**MODEL SERIES: P1204**

## Stationary Standby Electric Generator

**IMPORTANT SAFETY INSTRUCTIONS** – Please make certain that persons who are to install, operate and maintain this equipment thoroughly read and understand these instructions prior to operation. **SAVE THESE INSTRUCTIONS** — This manual contains important instructions that should be followed during installation and maintenance of the generator and battery.

*Product style and configuration may vary.  
Specifications are subject to change without notice.*

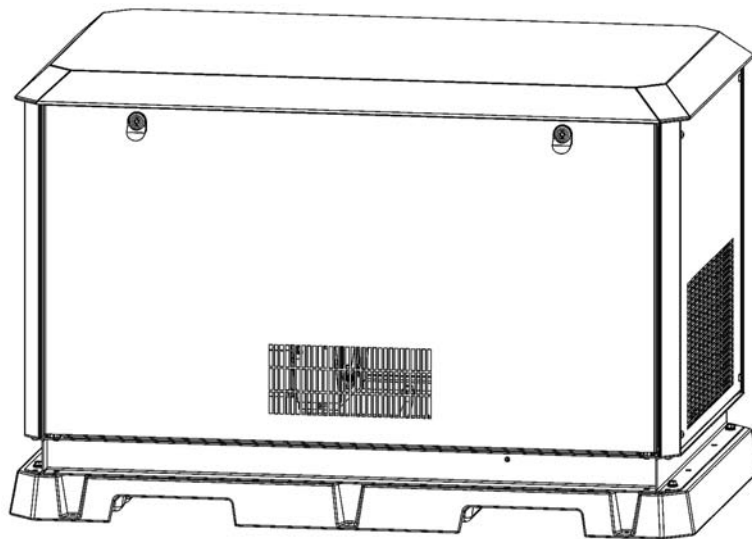

**⚠ WARNING:** Read and understand all safety precautions in this manual and other manuals included with this product before installing, operating and maintaining this equipment. Failure to comply with instructions in this manual could result in personal injury, property damage, and/or voiding of your warranty. The manufacturer **WILL NOT** be liable for any damage because of failure to follow these instructions.

Record the model and serial numbers of your generator below:

Model Number

\_\_\_\_\_

Serial Number

\_\_\_\_\_

Date Purchased

\_\_\_\_\_

**HELPLINE 1-866-769-3703**

# TABLE OF CONTENTS

Table of Contents . . . . .	2
General Safety Instructions . . . . .	3-4
Introduction . . . . .	5
Unpacking Instructions . . . . .	5
Installation Planning . . . . .	5
Specifications . . . . .	6
Installation Drawing . . . . .	7
Generator Installation . . . . .	8
Location and Generator Placement . . . . .	8-9
Automatic Transfer Switch . . . . .	10
Electrical Hookup . . . . .	11
Main Line Output Power . . . . .	11
Utility Circuit Supply . . . . .	12
Generator Start Signal . . . . .	12
Wiring Diagram . . . . .	13
Fuel Specifications & Consumption Requirements . . . . .	14
Fuel Consumption Table . . . . .	14
Fuel Hookup . . . . .	14
Natural Gas Settings . . . . .	15
Liquid Propane Vapor Settings . . . . .	15
Battery Requirements . . . . .	16
Battery Placement and Connection . . . . .	16-17
Lubrication . . . . .	17
First Time Startup . . . . .	18
Generator Operation . . . . .	18
Circuit Breaker . . . . .	19
Generator Control Panel Features . . . . .	19
Fuses . . . . .	19
Generator Control Panel Operation . . . . .	20
Starting The Generator . . . . .	20
Cyclic Crank . . . . .	20
Run State . . . . .	20
Shutdown . . . . .	20
Status Indicators . . . . .	21
Low Battery . . . . .	21
Engine Run . . . . .	21
Generator Control Panel - Faults . . . . .	21
Overcrank . . . . .	21
Overspeed . . . . .	21
High Temperature . . . . .	21
Low Oil Pressure . . . . .	21
Loss Speed . . . . .	21
Maintenance . . . . .	22-27
Maintenance Chart . . . . .	22
Engine Oil Level Check . . . . .	23
Engine Oil and Oil Filter Change . . . . .	24
Engine Oil Cooler Inspection and Cleaning . . . . .	24
Engine Air Filter Change . . . . .	25
Battery Maintenance . . . . .	25-26
Spark Plug Check . . . . .	26
Enclosure And Site . . . . .	27
Valve Clearance Check And Adjustment . . . . .	27
Fuel System Inspection . . . . .	27
Troubleshooting . . . . .	28-29
Notes . . . . .	30
Limited Warranty . . . . .	31
Service Information . . . . .	32

## GENERAL SAFETY GUIDELINES

The following information relates to protecting YOUR SAFETY and PREVENTING EQUIPMENT PROBLEMS. To help you recognize this information, we use the following symbols. Please read the manual and pay attention to these sections. Also read and follow all safety labels on the engine/generator set. If labels are damaged or unreadable, contact product service for replacements.



**This is the safety alert symbol. It is used to alert you to potential personal injury hazards. Obey all safety messages that follow this symbol to avoid possible injury or death.**



**Ground Location.**

**⚠ DANGER:** – A POTENTIAL HAZARD THAT WILL CAUSE SERIOUS INJURY OR LOSS OF LIFE.

**⚠ WARNING:** – A POTENTIAL HAZARD THAT COULD CAUSE SERIOUS INJURY OR LOSS OF LIFE.

**⚠ CAUTION:** – A POTENTIAL HAZARD THAT MAY CAUSE MODERATE INJURY OR DAMAGE TO EQUIPMENT.

**NOTE:** Improper installation can damage your electrical system and cause property damage, serious personal injury or death. Installation **MUST** be performed by a licensed electrician, plumber and gas technician. Installation **MUST** comply with all applicable building and electrical codes. Some areas may require building permits and/or detailed sight inspections prior to approving the unit for operation.

**NOTE:** The important safety instructions appearing in this manual are not meant to cover all possible conditions and situations that may occur. It must be understood that common sense, caution, and care are factors which are not built into a generator, but are supplied by the person(s) installing, maintaining, and operating it.

### **⚠ WARNING:**

**⚠** Do not attempt to install the generator yourself. Extremely high and dangerous electrical voltages are present in utility power source lines and in generator load leads when the unit is running. Therefore, be sure to turn OFF all power voltage supplies at their source before attempting to complete electrical connections. Only qualified installation contractors or electrician's who are familiar with applicable codes, standards, regulations and procedures should install the system. Improper or unauthorized installation, operation, or service of this equipment is extremely hazardous and may result in serious personal injury or death.

**⚠** It is NOT intended that the information in this manual be used by any unqualified persons for the purpose of installing a standby electric power system. This equipment must be installed, inspected, tested and adjusted only by qualified personnel. These people must be familiar with the equipment and installation requirements.

**⚠** The installation of this unit must comply with the regulations of the United States National Electric Code (NEC) as well as state and local codes and Occupational Safety and Health Administration (OSHA) established in the United States.

**⚠** This equipment, when installed as part of a standby electric power system, must be installed in conjunction with an approved transfer switch. The transfer switch serves to prevent both generator and utility power from being connected to the load

circuits at the same time. A properly connected transfer switch helps to prevent backfeed of generator power into commercial lines while the standby generator is operating.





**⚠** This generator supplies extremely high and dangerous power voltages. Any contact with high voltage electrically "hot" components will result in extremely hazardous, and possibly LETHAL, electrical shock. Use care to avoid contact with live terminals, bare connectors, bare wires, etc. Disconnect all power before performing maintenance or service.

**⚠** Generator exhaust air contains carbon monoxide, a deadly odorless, colorless and tasteless gas. Breathing carbon monoxide causes severe nausea, fainting or death. Install the generator set outdoors only. Do not use exhaust air to heat a room. Do not allow exhaust air to enter a building through windows, doors, air intakes or other means. Avoid breathing exhaust air while installing, operating or servicing generator set. The engine exhaust from this product contains chemicals known to the State of California to cause cancer, birth defects, or other reproductive harm.





**⚠** Short circuits can cause bodily injury and/or equipment damage. Do not contact electrical connections with tools or jewelry, make sure clothing and shoes are dry and stand on a dry wooden platform while adjustments are made. Remove wristwatch, rings, and jewelry that can cause short circuits.

## GENERAL SAFETY GUIDELINES (Continued)

### **WARNING:**

-  The National Electrical Code (NEC) requires the frame and external electrically conductive parts of the generator to be connected to an approved earth ground.
-  Keep a fire extinguisher near the generator at all times. Extinguishers rated "ABC" by the National Fire Protection Association are appropriate for use on the standby electric system. Keep the extinguisher properly charged and be familiar with its use. If you have any question pertaining to fire extinguishers, consult your local fire department.
-  Generator/engine noise can cause hearing loss. Never operate the generator set without a muffler or with a faulty exhaust system. Always wear hearing protection when near or operating the generator.
-  **DO NOT** permit anyone to operate the standby electric system without proper instruction.
-  In case of accidents caused by electric shock, immediately shut down the source of electrical power. If this is not possible, attempt to free the victim from the live conductor. **AVOID DIRECT CONTACT WITH THE VICTIM.** Use a nonconducting implement, such as a rope or board, to free the victim from the live conductor. If the victim is unconscious, apply first aid and get immediate medical help.

### **CAUTION:**

-  Units with broken or missing parts, without protective housing or covers should never be operated. Contact your service center for replacement parts.
-  Inspect the generator regularly, and contact your nearest Authorized Dealer for parts needing repair or replacement.
-  Never use the generator or any of its parts as a step. Stepping on the unit can stress and break parts, and may result in dangerous operating conditions from leaking exhaust gases, fuel leakage, oil leakage, etc.
-  Thoroughly read the **OPERATORS MANUAL** before operating the generator. Safe operation and top performance can be obtained only when equipment is operated and maintained properly.
-  Ensure that enclosure doors are closed and locked at all times other than during service.

## INTRODUCTION

The stationary standby electric generator is manufactured for our customers to supply reliable backup power. The generator is a compact unit, designed to supply the power for your critical needs when utility power fails.

The standby generator will run on Liquid Propane Gas or Natural Gas allowing flexibility for getting the power you need. Fuel lines should be installed by a licensed plumber or other qualified professionals or licensed gas technician.

### ⚠ WARNING

#### RISK OF ELECTROCUTION AND/OR INJURY



- **The installation of this equipment must be done by licensed electrician's, contractors and gas technicians or plumbers. Installation must be completed in conformance with NEC and local electrical and building codes. Some areas may require building permits and/or detailed sight inspections prior to approving the unit for operation.**

#### •About the Owners Manual

Understanding the operation of the generator is important when using or maintaining your system. If there are any questions about the information supplied in this Owner's Manuals, call our customer service helpline number shown on the manual cover.

#### •About Operation or Maintenance

All required safety checks that need to be performed are the responsibility of the operators. Listed within the Owners Manual are safety precautions that need to be followed to prevent personal injuries to persons around the unit and to prevent property damage.

## UNPACKING INSTRUCTIONS

Immediately inspect the generator carefully for freight loss or damage upon arrival. If loss or damage is noted at the time of delivery, require the person making the delivery to note the loss or damage on the freight bill, or affix his signature under the consignor's memo of the loss or damage. Contact the carrier for claim procedures.

When loss or damage is noted after delivery, segregate the damaged material, and contact the carrier for claim procedures. Be sure to retain the packaging material for carrier inspection.

"Concealed Damage" is understood to mean damage to the contents of a package which is not evident at the time of delivery by the carrier, but which is discovered later. The carrier or carriers are responsible for merchandise lost or damaged in transit. The title to goods rests with the consignee when generators are shipped F.O.B. factory, and only the consignee can legally file a claim.

After inspecting the generator, engine and enclosure for physical damage, finish reading the Operating and Maintenance Instructions. These manuals contain important safety information.

### ⚠ WARNING

#### RISK OF INJURY AND BEING CRUSHED



- **HEAVY EQUIPMENT. Unbalanced weight. Improper lifting can cause severe injury or death and equipment damage.**
- **When lifting the generator or using hoisting equipment, be careful not to touch overhead power lines. Proper tools and equipment and qualified personnel should be used in all phases of handling and unpacking.**

## INSTALLATION PLANNING

### ⚠ DANGER

#### RISK OF INJURY



- **Improper installation can damage your electrical system and cause property damage, serious personal injury or death. Installation MUST be performed by a licensed electrician and plumber or gas technician. Installation MUST comply with all applicable building and electrical codes. Some areas may require building permits and/or detailed sight inspections prior to approving the unit for operation.**

Taking a few moments to pre-plan before beginning installation of the generator can provide significant savings in materials and labor and lower future maintenance. Some items to consider in planning generator installation are safe generator operation, use of an Automatic Transfer Switch, load requirements, generator location, fuel supply, environmental conditions and applicable local, regional or national codes. Some areas may require building permits and/or detailed site inspections prior to approving the unit for use. Check with local authorities before starting installation.

Installation of a standby engine/generator system is complex and should not be considered a Do-It-Yourself project. Safe installation requires the skill and knowledge of licensed electrician's and plumbers or gas technicians. Contact an authorized dealer for assistance with installation planning and referral to properly qualified, licensed installing contractors.

## GENERATOR SPECIFICATIONS

	<b>P120401 (12 KW)</b>
Rated Wattage - (Standby) @1.0 PF LPG *	12,000
Rated Wattage - (Standby) @1.0 PF NG *	9,800
Voltage	120/240 volts
Rated Current	100/50 amps LPG
Frequency	60 HZ
Power Factor	1.0
Max. Ambient Temp Rise	105°C
Insulation class	H
Engine	Subaru EH72
Engine Type	Air cooled V-twin (2 cylinders)
RPM	3600
Displacement cc (c.i.d)	43.9 cu. in. (720 cm <sup>3</sup> )
Bore X Stroke mm (inches)	2 - 3.31 in. x 2.56 in. (84 mm x 65 mm)
Compression Ratio	8:1
Valve arrangement	Overhead valve
Governor	Centrifugal Flyweight Type
Ignition system	Flywheel Magneto (Solid State)
Starter	Electric Starter
Alternator	12vdc
Oil Capacity (w/o filter)	1.5 qts (1.42L)
Oil Capacity (with filter)	1.8 qts (1.70L)
Oil Filter	See Engine Manual
Cooling System	Forced Air
Spark plug	NGK BPR6ES
Battery	BCI Group 26 or 26R, minimum 450 CCA
Air filter	See Engine Manual
Minimum Content Requirements for Natural Gas (NG) **	1000 BTU's per cubic foot
Minimum Content Requirements for Liquid Propane Vapor (LPG) **	2520 BTU's per cubic foot
Consumption at Full Load for Natural Gas (NG)	315 cubic feet per hour
Consumption at Full Load for Liquid Propane Gas (LPG)	3.99 gallons per hour
Dimensions (see next page for installation drawing)	47"L x 29"W x 31"H
Shipping Weight	550
Normal Operating Range	-20°F (-28.8°C) to 104°F (40°C)

\* Note: Rated wattage is specified at sea level, 60°F ambient temperature, and propane fuel (with 2500 BTU/cuft). Rated wattage decreases approximately 3.5% for each 1000ft above sea level and approximately 1% for each 10°F above 60°F ambient temperature.

\*\* Fuel supply pressures must be between 4 oz (6" w.c.) and 6 oz (11" w.c.) at inlet to the unit.

# INSTALLATION DRAWINGS

BACK SIDE

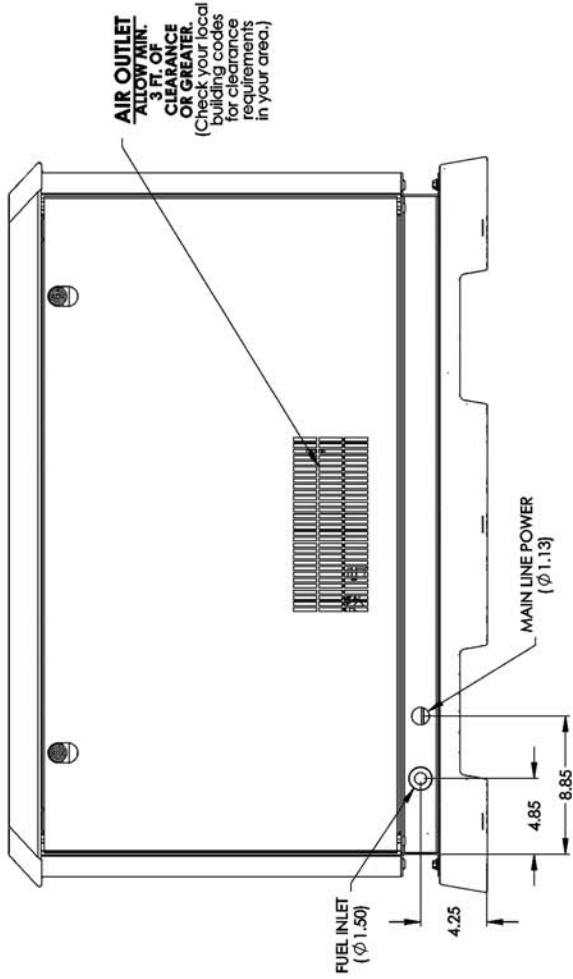

BOTTOM

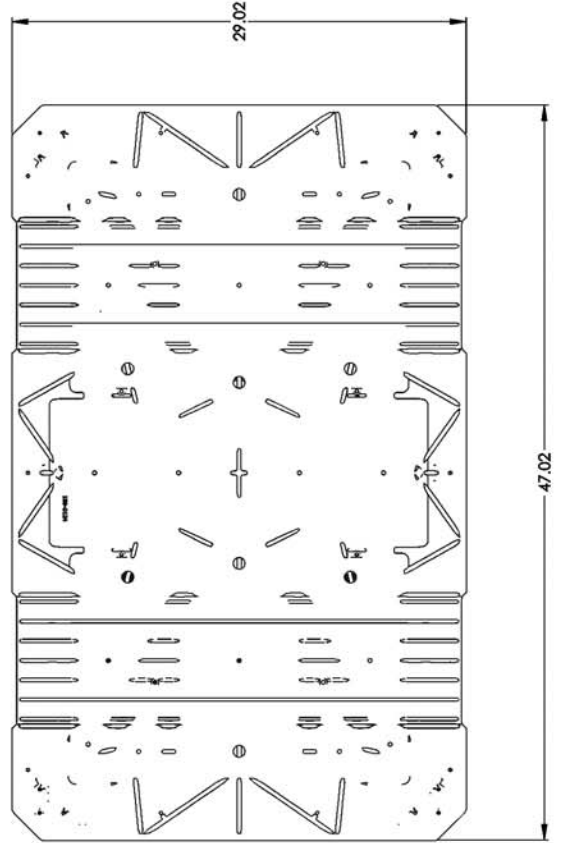

EXHAUST END

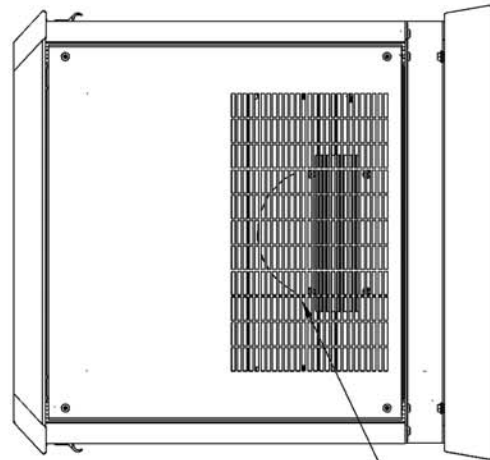
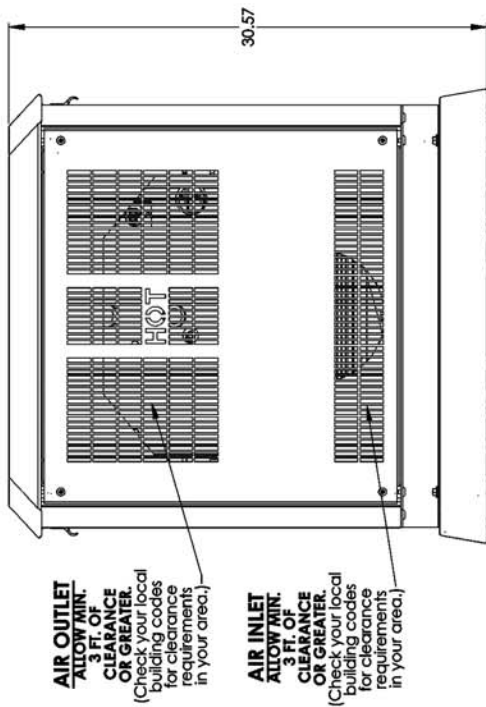

## GENERATOR INSTALLATION

Once installation planning is complete and all necessary local permits are granted, installation of the generator may begin. Within the following section general recommendations are given for installing the generator. However, installations are affected by local site conditions, regional construction practices, material availability, local or regional codes and/or other variables. Therefore, recommendations included in this manual are provided as a guide only and are not meant to serve as detailed installation plans. All decisions regarding installation and materials are at the discretion of the licensed electrician's and licensed plumbers performing the installation and/or the inspector performing the final inspection as required by local or regional code. Additionally, illustrations provided in this manual are subject to ongoing revisions and shall not be construed as blueprints.

## LOCATION AND GENERATOR PLACEMENT

For proper ventilation and maintenance, locate the generator outdoors in an area that will allow a minimum of three feet or more of clearance between the generator and any other structure. **Note: Check your local building codes for clearance requirements for your area.**

When placing the generator, the direction of the exhaust should be pointing away from windows, doors and any ventilation system.

Insure that sufficient air flow is available to remove the exhaust fumes and cool the generator properly.

**NOTE:** It would be extremely difficult, if not impractical, to attempt a detailed coverage of every installation possibility. For that reason, much of the information is general in nature. Plan the installation carefully. Information in this manual is provided as a guide only and is not meant to serve as a detailed installation plan. Illustrations provided in the manual must not be construed as blueprints.

**NOTE:** The generator has an engine fan that draws the air in from the end panel slots, circulates it within the enclosure and forces the air through the side panels and the exhaust panel slots.

All local applicable codes, standards and regulations must be followed for the installation of the generator. Some areas may require building permits and/or detailed sight inspections prior to approving the unit for use.

**NOTE:** Utility wiring from the house to power the battery charger and other start assisting components should be tightened on the identified terminal block at a torque of 20 lb-in. The wire size is to be selected according to allowable ampacities given in Table 310-16 of the National Electric Code.

Signal wiring from the transfer switch is to be 18AWG multi-strand wire tightened on the identified terminal block to a torque of 20 lb-in.

Power leads from the generator/circuit breaker being wired to the transfer switch should be tightened in the identified terminal block to 120 lb-in. The wire size is to be selected according to allowable ampacities given in Table 310-16 of the National Electric Code.

Field wiring of this unit must be conducted by a licensed electrician.

### ⚠ WARNING



- Hazardous voltage can cause severe injury or death. Electrocutation is possible whenever electricity is present. Open the main circuit breaker of all power sources before servicing the equipment. Configure the installation to electrically ground the generator set, transfer switch and related equipment and electrical circuits to comply with applicable codes and standards. Never contact electrical leads or appliances when standing in water or on wet ground because these conditions increase the risk of electrocution.
- The exhaust from this product is extremely hot and remains hot after shutdown. High grass, weeds, brush, leaves, or other combustible materials, must remain clear of the exhaust. Such materials may ignite and burn from the heat of the exhaust system.

### ⚠ DANGER



- The generator engine exhaust fumes contain carbon monoxide, which can be DEADLY. This dangerous gas, if breathed in sufficient concentrations, can cause unconsciousness or even death. The generator must be installed properly, in strict compliance with applicable codes and standards. Following installation, you must do nothing that might render the generator unsafe or in noncompliance with such codes and standards.

### ⚠ CAUTION

- Covering or restricting the air passages on the generator will cause the unit to overheat and may create a fire hazard. Do not allow snow or leaves to cover enclosure openings.
- Leave a three foot or greater open area around all sides of the unit. *Check your local building codes for clearance requirements for your area.* Do not plant trees or plants close to the unit.
- Unit should be located such that it prevents combustible material from accumulating under the generator set.



## PLACEMENT AND ANCHORING

The generator is supplied with an integral molded plastic base for use as an installation pad. Use of this base is intended to minimize installation cost by eliminating the need for a poured concrete pad.

A pad of crushed gravel a minimum of three inches thick is recommended as a base to set the generator on. Compact the gravel and ensure that the pad is level in all directions, making sure that the overall pad height is greater than the surrounding grade with a slope to carry water away from all sides of the pad. Pad dimensions at least six inches larger than the base size in all directions are recommended.

It is possible to use a standard concrete pad if desired. When using this method, a lightly steel reinforced pad a minimum of 2 inches thick, poured to local codes is recommended. Ensure the pad extends past the generator pallet and is high enough to promote drainage of water away from the generator.

After preparing the base pad (C), position the generator (A) directly on the pad, complete with the wooden skids supplied for shipping. Remove the lag bolts (B) fastening the wood to the pallet from all six positions. Using a pry bar with a block of wood as a pivot, carefully lift one end of the pallet and remove the wooden skids from both that end and the center of the pallet (D). Lower the pallet to the pad, then pry the other end up and remove the skid from that end (E). Check the generator with a level in all directions, placing material under the base as required.

Although the weight of the generator is adequate to prevent movement during normal operation, anchoring of the generator is recommended. To anchor the generator on a gravel pad, drive a minimum of four (4) spikes through the anchoring tabs located on the outside corners of the pallet. If a concrete pad is used, anchor the pallet at the same points using appropriate concrete fasteners.

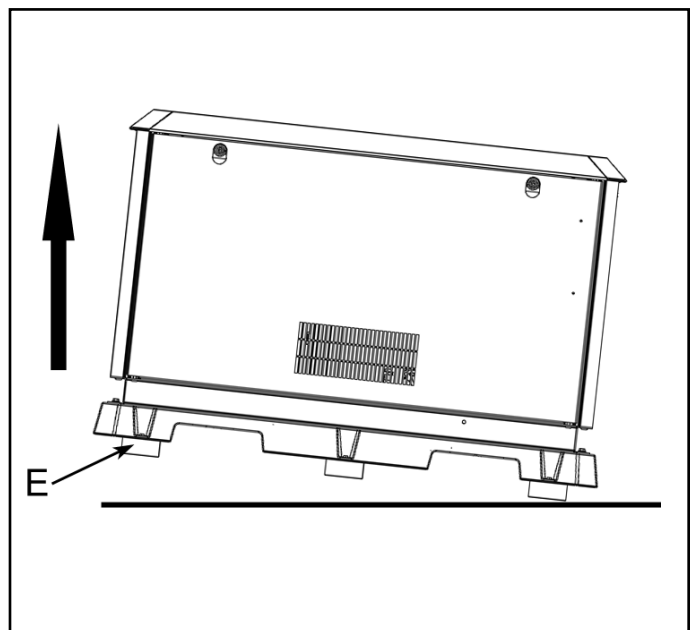
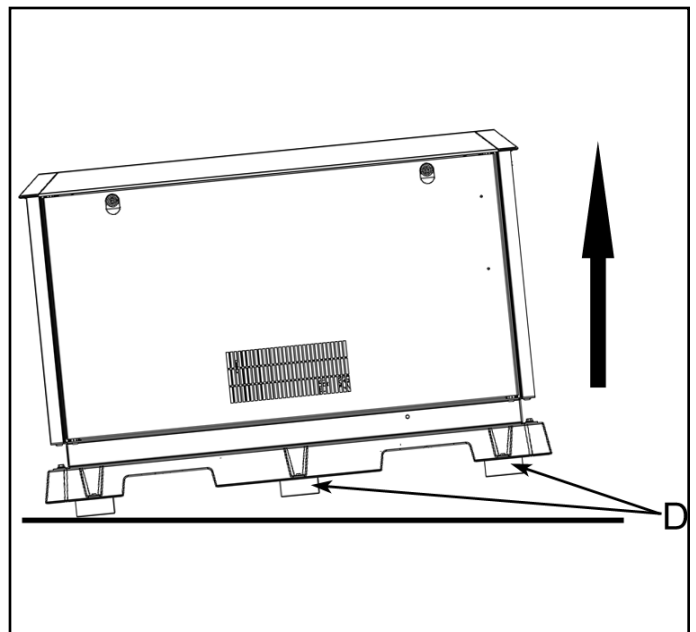
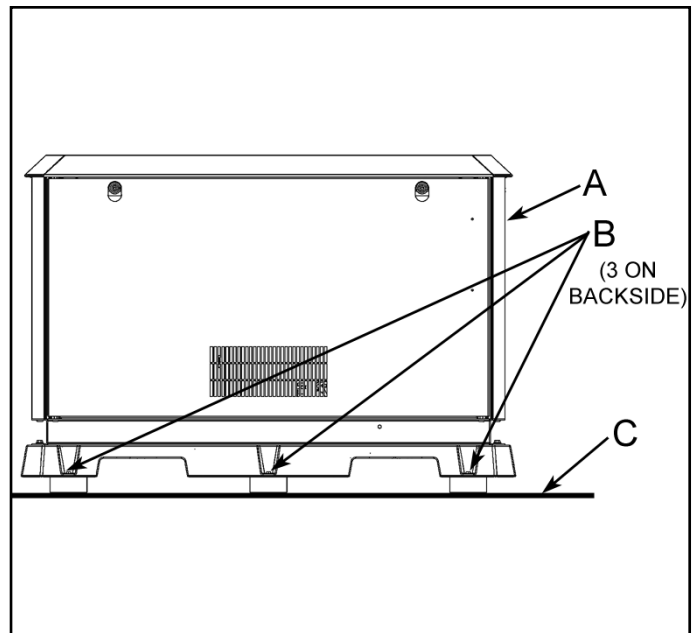

### ⚠ WARNING



- For fire safety, the generator must be installed and maintained properly. Installation always must comply with applicable codes, standards, laws and regulations. Adhere strictly to local, state and national electrical and building codes. Comply with regulations the Occupational Safety and Health Administration (OSHA) and National Electrical Code (NEC) have established.
- This generator is designed to be installed outside only. Never install this unit inside any room, enclosure, or basement. The generator needs adequate cooling and ventilation for continued proper and safe operation.

## AUTOMATIC TRANSFER SWITCH

When connecting the generator to a building electrical distribution system, use of a transfer switch is recommended to isolate the normal utility source from the generator supply. By preventing backfeed of the generator power into the utility lines during a utility power outage, the switch provides a level of safety for electrical line workers. An automatic transfer switch listed to Underwriters Laboratories Standard 1008 performs this function while also supplying a method to automatically start and stop the generator set and transfer power to the building electrical system from an appropriate source.

When planning for a transfer switch/generator installation, it is necessary to know the method of interconnection to the building system. As illustrated, it is recommended to connect the generator to power only circuits that are necessary during a power outage. When following this method, the transfer switch feeds only the necessary circuits. Another option is to connect the transfer switch directly to the entire building electrical distribution system. In this case, all circuits or loads must be controlled to avoid overloading and possibly damaging the generator set.

Switch selection is based on factors such as the size of the building distribution system, available generator power and required generator control system. Due to the

complex nature of electrical distribution systems, the sizing, selection and installation of a switch is best handled by a licensed electrician or qualified standby generator dealer. Any switch installation must be performed by a licensed electrician to the instructions of the switch manufacturer and any applicable local, regional or national codes.

**⚠ WARNING**



- **Hazardous "backfeed" voltage can cause severe injury or death. Install a transfer switch in standby power installations to prevent connection of standby and other sources of power. Electrical backfeed into a utility electrical system can cause serious injury or death to utility personnel working on transmission lines.**
- **Do not try MANUAL operation of the transfer switch until all power supplied to the switch has been positively turned OFF. Failure to turn OFF power supplied may result in extremely dangerous and possibly lethal electrical shock or arcing.**

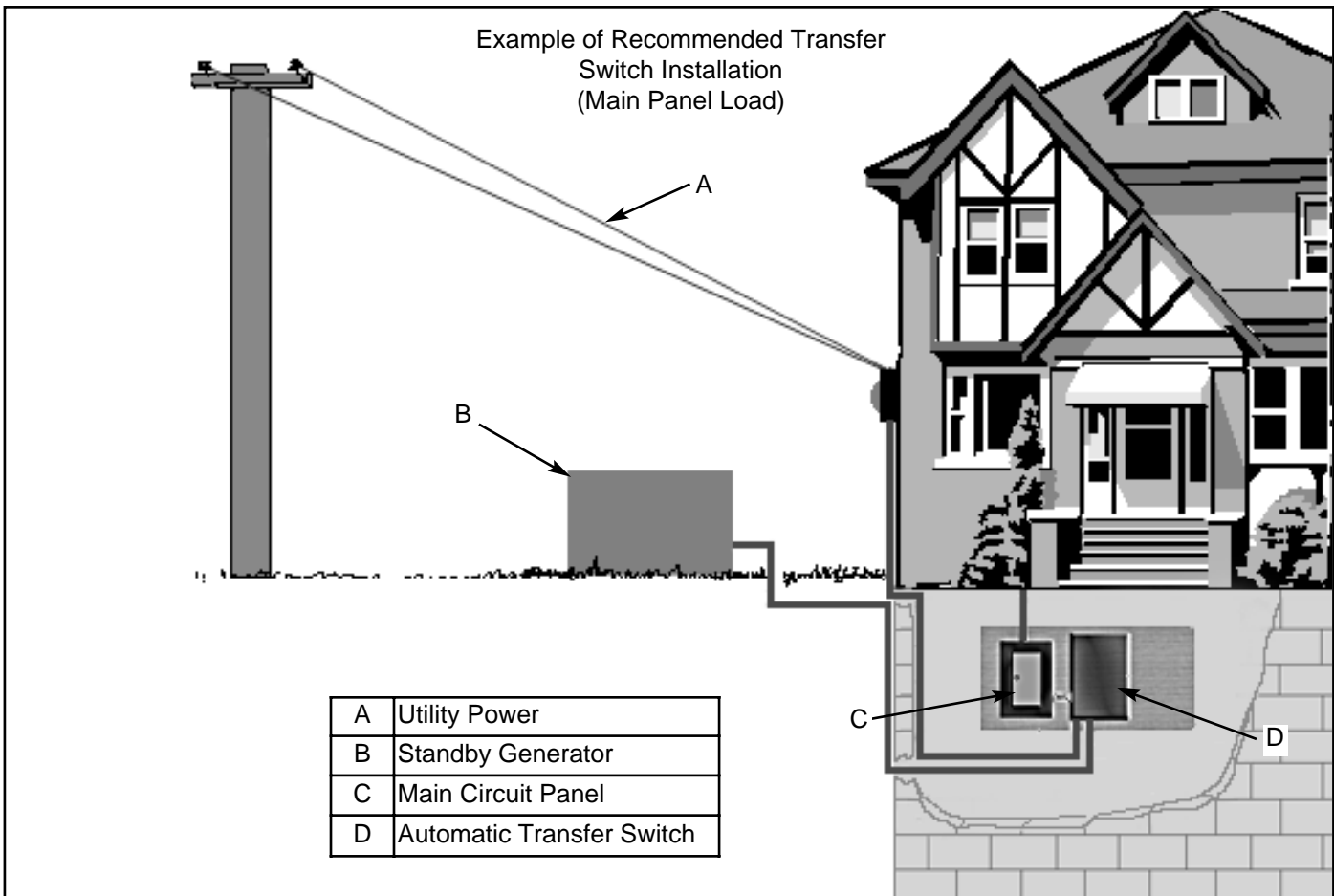

## ELECTRICAL HOOKUP

Once the generator is anchored in its final position, it is ready for electrical connections. The generator is supplied with two terminal blocks for connection of three distinct electrical circuits; main line output power, utility power input and generator start signal. Main line output power is the electrical output of the generator, utility input powers the battery charger and optional block heater devices and the generator start signal is the interface with an Automatic Transfer Switch that allows the generator to operate automatically upon a utility power outage.

### ⚠ DANGER



- Improper installation can damage your electrical system and cause property damage, serious personal injury or death. Installation **MUST** be performed by a licensed electrician and plumber, or gas technician and installation **MUST** comply with all applicable building and electrical codes. Some areas may require building permits and/or detailed sight inspections prior to approving the unit for operation.

## MAIN LINE OUTPUT POWER

The output circuit of the generator is 4-wire, 240V, rated for the amperage as shown on the generator nameplate. Connection to the transfer switch requires two leads, commonly referred to as "hot" leads (L1 & L2), a neutral (N), and ground lead. Positions of these leads are labeled on the main line output terminal block, also shown in Fig. A. **Select proper power output wire sizes according to allowable ampacities given in Table 310-16 of the latest revision of The National Electric Code(NFPA 70).** To connect the wires, strip the insulation back approximately ½" from the end of the wire, insert the stripped end into the terminal block, then torque the terminal block screw to **35 in-lbs (4.0 N-m)**.

### ⚠ WARNING



- In case of accidents caused by electric shock, immediately shut down the source of electrical power. If this is not possible, attempt to free the victim from the live conductor. **AVOID DIRECT CONTACT WITH THE VICTIM.** Use a nonconducting implement, such as a rope or board, to free the victim from the live conductor. If the victim is unconscious, apply first aid and get immediate medical help.

### FIELD CONNECTIONS TO BE PERFORMED BY A LICENSED ELECTRICIAN

N	
Generator Output	Ground
Puissance fournie par le générateur	Mise à la terre
Salida del generador	Tierra
	098-3975
Use CU Conductors Only	
Utiliser des conducteurs au cuivre seulement	
Utilizar conductores de cobre exclusivamente	

L1 LEAD TO TRANSFER SWITCH

L2 LEAD TO TRANSFER SWITCH

NEUTRAL (N) LEAD TO TRANSFER SWITCH

GROUND LEAD TO TRANSFER SWITCH

LABEL 098-3975

Fig. A

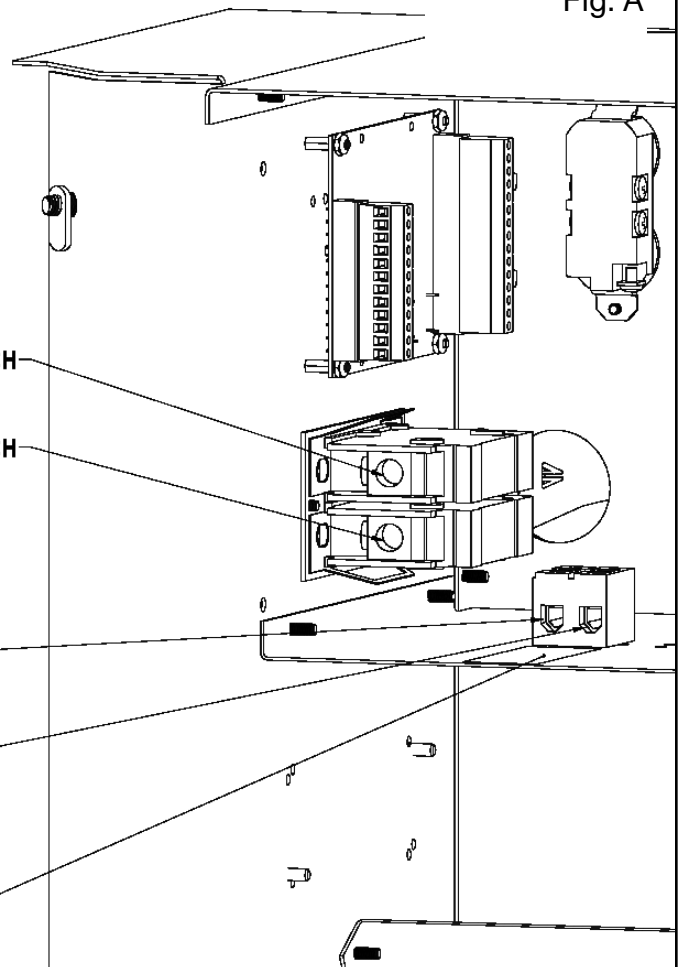

## UTILITY CIRCUIT SUPPLY

A receptacle is provided with the generator to power the battery charger for reliable starting. It is also intended to power an optional block heater if that option is desired. Connection of this circuit to a power supply that is only present when normal utility power is supplied is recommended. By connecting the receptacle in this fashion, it is possible to insure that neither the battery charger or block heater are on while the engine is running. Precautions are engineered into the generator to prevent these occurrences but connection of the circuit in this fashion provides an additional fail-safe method of engine and battery protection.

Input to the utility circuit is 3-wire, 120V, 15A. Connections include a "hot" lead (L1), neutral (N) and ground lead. Positions of the incoming wire connections are labeled at the auxiliary connection block, shown in Fig. B. **Select proper utility supply wire size according to allowable ampacities given in Table 310-16 of the latest revision of The National Electric Code(NFPA 70).** To connect the wires, strip the insulation back approximately ¼" from the end of the wire, insert the stripped end under the screw and washer on the terminal block, then torque the terminal block screw to **20 in-lbs (2.3 N-m).**

## GENERATOR START SIGNAL

When the control panel mode switch is placed in the AUTO position, generator starting and stopping is controlled by the opening or closing of a set of voltage free contacts. Two wires from those contacts are connected to the generator through the auxiliary connection block shown in Fig. B. Use of a twisted pair of stranded copper wire no smaller than AWG 18 gage is recommended. To insure proper operation of the auto start feature, use a transfer switch offering "close-to-run control contacts. To connect the wires, strip the insulation back approximately ¼" from the end of the wire, insert the stripped end under the screw and washer on the terminal block, then torque the terminal block screw to **20 in-lbs (2.3 N-m).**

**NOTICE: A field-installed conductor is not required to be separated from a field wiring terminal of a different circuit when the field wiring is insulated for the maximum voltage of either circuit and both circuits are Class 2 or Class 3, or both circuits are other than Class 2 or Class 3.**

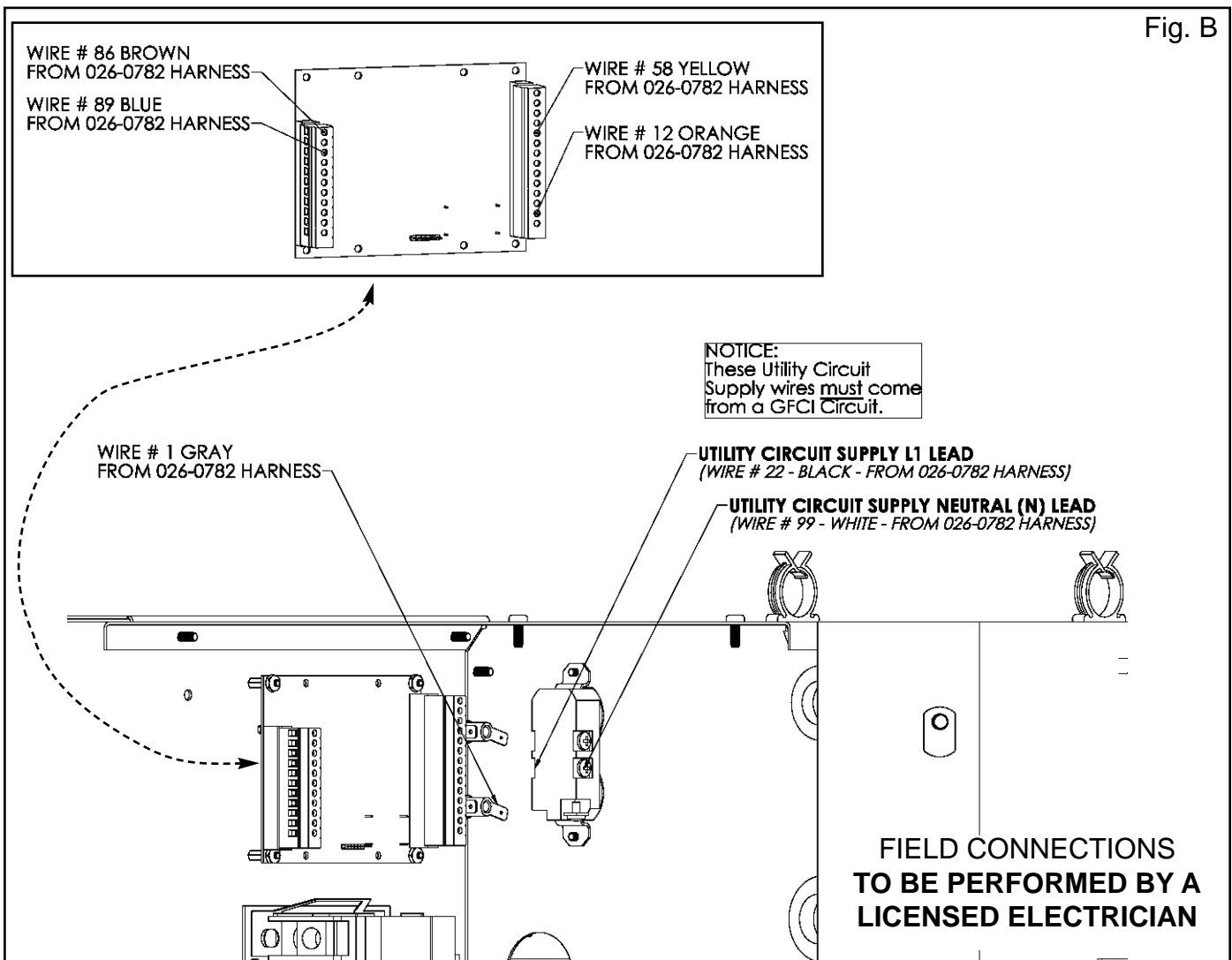
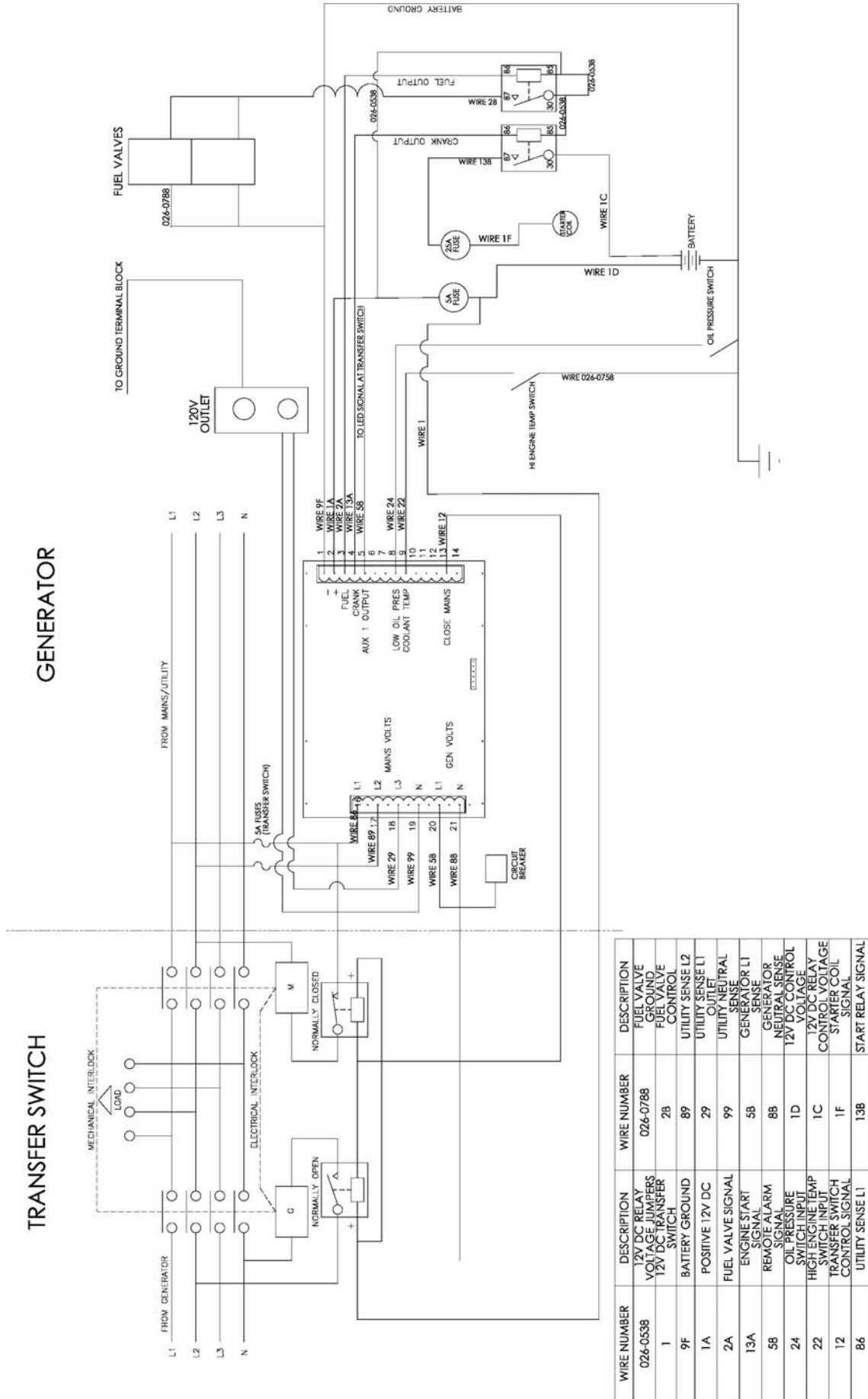

Fig. B

# WIRING DIAGRAM



## TRANSFER SWITCH

## GENERATOR

WIRE NUMBER	DESCRIPTION	WIRE NUMBER	DESCRIPTION
026-0538	12V DC RELAY VOLTAGE JUMPERS	026-0788	FUEL VALVE GROUND
1	12V DC TRANSFER SWITCH	28	FUEL VALVE CONTROL
9F	BATTERY GROUND	89	UTILITY SENSE L2
1A	POSITIVE 12V DC	29	UTILITY SENSE L1
2A	FUEL VALVE SIGNAL	99	UTILITY NEUTRAL SENSE
13A	ENGINE START SIGNAL	58	GENERATOR L1 SENSE
58	REMOTE ALARM SIGNAL	88	GENERATOR NEUTRAL SENSE
24	OIL PRESSURE SWITCH INPUT	1D	12V DC CONTROL SWITCH
22	HIGH ENGINE TEMP SWITCH INPUT	1C	12V DC RELAY CONTROL VOLTAGE
12	TRANSFER SWITCH CONTROL SIGNAL	1F	STARTER COIL CONTROL SIGNAL
86	UTILITY SENSE L1	138	START RELAY SIGNAL

## FUEL SPECIFICATIONS AND CONSUMPTION REQUIREMENTS

The engine driving the generator is engineered to provide reliable power on either Liquefied Propane Vapor (LPG) or Natural Gas. For proper operation on these fuels, it is important to deliver gas with adequate energy content, at sufficient pressure and flow rate. This generator is designed to operate on Liquefied Propane Vapor (LPG) with a minimum energy content of 2500 BTU per cubic foot or Natural Gas with a minimum energy content of 1000 BTU per cubic foot. This generator is designed to operate with a **fuel pressure** at the inlet of the unit between **6 and 11 inches of water column (4-6 ounces)**.

Required fuel flow rates for specific models are given in the table below. To insure correct sizing of the piping supplying fuel to the generator set, provide the flow and pressure requirements of this section to a fuel supplier or licensed plumber during the installation planning stage. If the fuel supplier cannot guarantee delivery of fuel with these properties, the generator may not perform as advertised.

Due to differences in the energy content of fuel used, it is necessary to derate the output of the generator when connected to Natural Gas. Additionally, regional and/or seasonal variations in the makeup of the fuel can further affect output of the engine/generator system. When using Natural Gas fuel with minimum properties as defined, engine output can fall approximately 10% below that of the same set using Propane Vapor.

**Per the National Gas Code (NFPA 54 - ANSI 2223.1), a manual shutoff valve in the fuel supply line to the generator is recommended.**

### DANGER

- All fuel system installations **MUST BE** done by a licensed plumber or licensed gas technician and must comply with all applicable codes, standards and regulations.

### FUEL CONSUMPTION TABLE

	P120401
Fuel Consumption (@100% load)	3.44 Gal/Hr (LP) 280 Cu-ft/Hr (NG)
All values reflect consumption at 100% rated output.	

### FUEL REQUIREMENTS:

For the best operation of the unit, the fuels used should have a minimum content of 1000 BTU's per cubic foot for Natural Gas (NG) and 2520 BTU's per Cubic foot for Liquid Propane vapor (LPG). Contact local fuel supplier for local BTU content. Fuel supply pressures must be between 4oz (6" H<sub>2</sub>O per square inch) and 6oz (11" H<sub>2</sub>O per square inch) at the inlet to the unit.

### WARNING

- Natural gas (NG) is highly explosive.
- Natural gas (NG) is lighter than air and will collect in high places.
- Liquid propane vapor (LPG) is highly explosive.
- Liquid propane vapor (LPG) is heavier than air and will collect in lower places.
- Extreme caution should be taken when working on a new installation or while performing general maintenance.
- Do not smoke when near the unit.
- Keep flames, sparks, pilot lights, arc-producing equipment, switches and all other sources of ignition well away. Keep a type ABC fire extinguisher handy.
- Potential for fire or explosion always exist when using natural gas (NG) or liquid propane vapor (LPG) as a fuel source. Install this unit in compliance with all local fuel codes.
- Do Not operate engine if smell of fuel is present or other explosive conditions exist.

### FUEL HOOKUP

After electrical connections are complete, the next installation step is to connect a fuel supply to the unit. The fuel inlet fitting supplied with the generator is male 3/4" NPT. To accommodate potential settling of the generator relative to rigid supply pipeline, use of a flexible line, provided by manufacturer, in the supply line is suggested. When making connections, use only materials rated for the fuel supplied and approved for use by local, regional or national codes and/or regulatory agencies.

### DANGER

- All fuel system installations **MUST BE** done by a licensed plumber or licensed gas technician and must comply with all applicable codes, standards and regulations.

### WARNING

- Natural Gas and Propane Vapor are highly explosive gases. Check ALL fuel system connections for leaks before starting engine/generator set.
- **DO NOT** use a flame to check for leaks.
- Use approved equipment and methods to check for leaks.

## Natural Gas (NG)

Units are tested with natural gas before they leave the factory. If natural gas is to be used, no adjustments are required.

When supplying natural gas as the operating fuel, provide fuel with a minimum of **1000 BTU/ft<sup>3</sup> at inlet pressures between 6" and 11" of water column (4 - 6 oz)**. Failure to meet these minimums will cause the generator to run poorly and/or may limit output to values below nameplate value. If fuel with these qualities is not available, contact the customer service center.

Refer to the Fuel Consumption Table on page 14 for fuel flow requirements for the unit installed. Size all feeding piping to deliver sufficient flow above the minimum pressure of 6" water column (4 oz).

**Per the National Gas Code (NFPA 54 - ANSI 2223.1), a manual shutoff valve in the fuel supply line to the generator is recommended.**

## Propane Vapor (LPG)

In cases where liquefied propane vapor is selected as the fuel of choice, insure fuel delivery in the gaseous state, with a minimum energy content of **2500 BTU/ft<sup>3</sup>, at inlet pressures between 6" and 11" of water column (4 - 6 oz)**. Fuel below these specifications may cause improper engine operation and/or failure to deliver rated generator output. Size all fuel system plumbing to provide fuel flow as given in the Fuel Consumption Table on page 14, at a minimum pressure of 7" water column (4 oz).

After completing external supply connections, follow the instructions listed below to change over to LPG.

1. Remove the front panel by inserting the key into the locks located on top of the panel. and turn 1/4 turn counterclockwise to unlock. Lift the panel up and out of the base and set it aside.
2. Remove the air filter cover (A) by turning the air filter cover nut (B) counterclockwise.
3. Remove the air filter (C).
4. Remove the 3 bolts (10mm) (D) from the air filter base (E) and set it aside. Note: be careful not to drop the bolts into the carburetor.
5. Loosen the fuel hose clamp (F) and remove the fuel hose (G).
6. Insert the orifice (H) (included) and tighten by turning clockwise.
7. Put the fuel hose and clamp back on and tighten the clamp.
8. Place the air filter base back onto the carburetor and tighten the 3 bolts.
9. Place the air filter back onto the center stud.
10. Replace the air filter cover and air filter nut and tighten.
11. Install the panels back onto the generator by placing the bottom of the panel onto the base and pushing it up into place. Lock the panel by inserting the key into the locks and turning 1/4 turn clockwise.

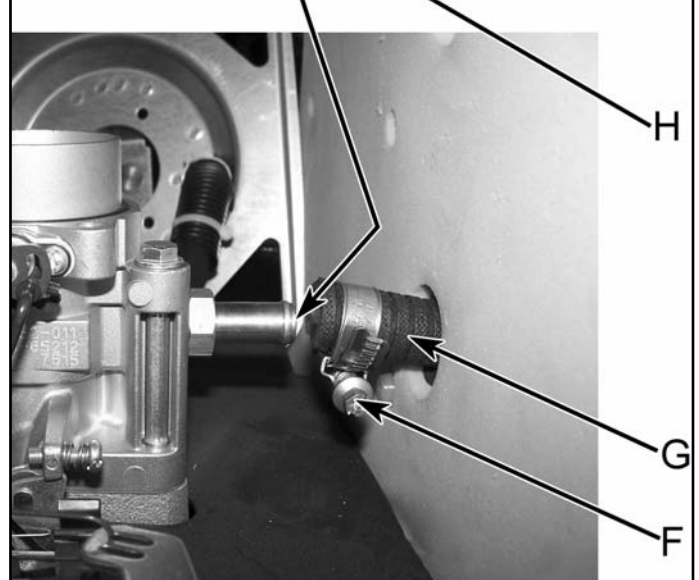
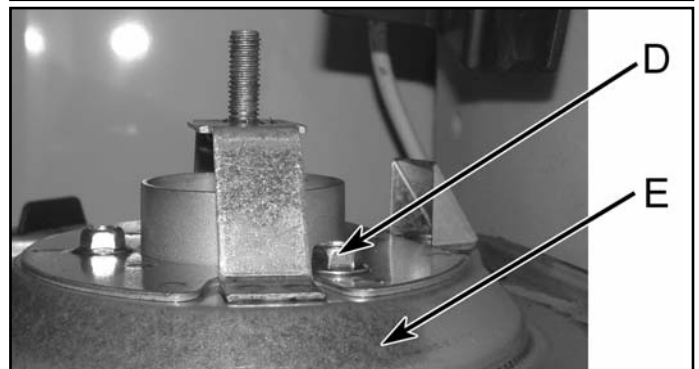
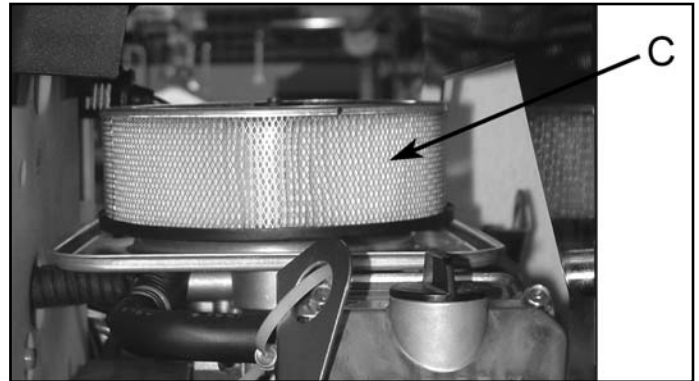
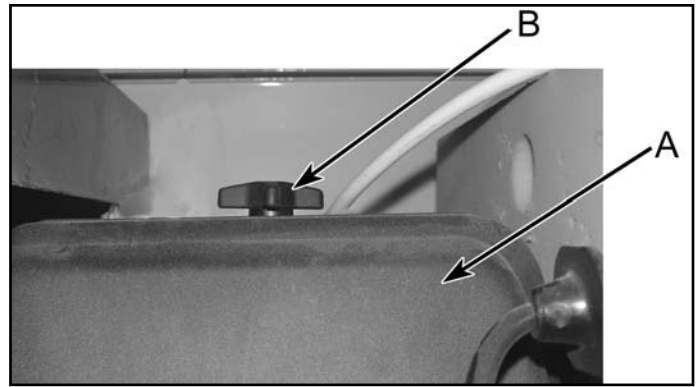

## BATTERY REQUIREMENTS

To insure reliable starting in most weather conditions, it is important to properly match a battery to the requirements of the generator. The generator uses a 12 Volt, direct current, negative ground control system powered by an automotive style lead acid battery. Successful engine starting is dependent upon the cranking speed of the engine, which in turn is affected by the cranking capacity of the battery. When selecting a battery, choose the model that provides the highest available cold cranking amperes (CCA) within a given size range, as specified by the Battery Council International (BCI). The battery tray and cables supplied with the generator are sized to accept a **BCI Group 26 or 26R battery**, with a minimum recommended rating of **450 CCA**.

### ⚠ WARNING



Lead-acid batteries present a risk of fire because they generate hydrogen gas. The following procedures are to be followed:

- Do not smoke when near batteries.
- Do not cause flame or spark in battery area.
- Discharge static electricity from body before touching batteries by first touching a grounded metal surface.
- Do not dispose of batteries in a fire. The battery is capable of exploding.
- Do not open or mutilate the battery or batteries. Released electrolyte has been known to be harmful to the skin and eyes and to be toxic.

### ⚠ WARNING



The electrolyte is a dilute sulfuric acid that is harmful to the skin and eyes. It is electrically conductive and corrosive. The following procedures are to be observed.

- Wear full eye protection and protective clothing.
- Where electrolyte contacts the skin, wash it off immediately with water.
- Where electrolyte contacts the eyes, flush thoroughly and immediately with water and seek medical attention.
- Spilled electrolyte is to be washed down with and acid neutralizing agent. A common practice is to use a solution of one pound (500 grams) bicarbonate of soda to one gallon (4 liters) of water. The bicarbonate of soda solution is to be added until the evidence of reaction (foaming) has ceased. The resulting liquid is to be flushed with water and the area dried.

## ⚠ CAUTION



A battery presents a risk of electrical shock and a high short circuit current. The following precautions are to be observed when working on batteries:

- Remove watches, rings or other metal objects.
- Use tools with insulated handles.
- Wear rubber gloves.
- Do not lay tools or metal parts on top of batteries.
- Disconnect charging source prior to connecting or disconnecting battery terminals.
- Determine if the battery is inadvertently grounded. When inadvertently grounded, remove source of ground. Contact with any part of a grounded battery is capable of resulting in electrical shock. The risk of such shock is reduced when such grounds are removed during installation and maintenance.
- Failure to connect and disconnect in the proper sequence can cause equipment damage. Ensure there is a clean tight fit from the cables to the post.

## BATTERY PLACEMENT AND CONNECTION

The next step in installation of the generator is placement and connection of the engine cranking battery. Provided battery cables are sized to accept a **BCI Group 26 or 26R** automotive style battery. A battery with a minimum of **450 CCA** (cold cranking amperes) in this size range is recommended to assure reliable engine starting.

### ⚠ WARNING



- Make sure the control panel Mode switch is in the OFF position before connecting the battery cables. Failure to do so may result in unexpected engine starting and to personal injury.



## BATTERY PLACEMENT AND CONNECTION (cont.)

To access the battery and charger, remove the front and back panels by inserting the key into the locks located on top of the panel, and turn 1/4 turn counterclockwise to unlock. Lift the panels up and out of the base and set it aside.

Place the battery (A) on the base as shown in Fig G.

After the battery is set, begin attaching the battery cables to the battery posts, starting with the positive (+), or red, cable (B). Loosen the bolt (C) on the post clamp slightly to allow the clamp to expand, then firmly push the clamp onto the battery post marked positive (+) until the top of the post extends past the top of the clamp. Rotate the clamp around the post as required to insure the clamp cannot contact any metal components, then tighten the clamp bolt (C) until snug. Finally, slide the post boot (D) down the cable and place it entirely over the clamp.

Finish connecting the battery by placing the negative (-), or black, battery cable (E) to the battery post marked negative (-). Push the clamp firmly over the post until the post extends past the top of the clamp, then rotate the clamp to avoid contact with any metal parts. Tighten the battery clamp bolt (F) until snug.

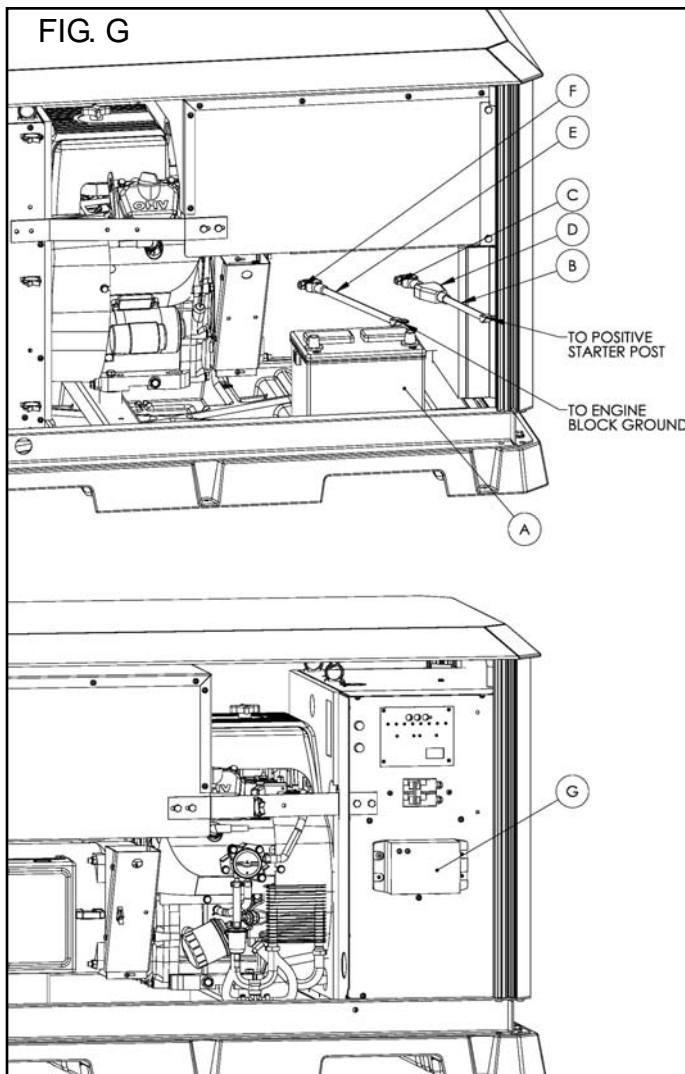

200-2667

The final step of battery installation is to verify proper connection of all battery charger connections. A battery charging system (G) is included with the engine/generator set to maintain the battery charge during extended periods of generator inactivity, therefore providing consistent starting. A quick check of charger connections will verify that factory connections are correct so the charger can function as intended. Insure that the charger is connected by checking to see that it is plugged into a powered receptacle, and that the positive (+) and negative (-) charger cables are connected to their respective battery cables.

Install the panels back onto the generator by placing the bottom of the panel onto the base and pushing it up into place. Lock the panel by inserting the key into the locks and turning 1/4 turn clockwise.

## LUBRICATION

Once all connections are made, the final installation step is verification of proper engine oil level. Check oil level before start-up (see page 23 for instructions). The unit is shipped with the proper type of oil in the crankcase for operation above 40°F. Follow the engine manufacturer's recommendations for oil at temperatures below 40°F. Check oil periodically to ensure that the unit is properly lubricated. Follow the engine manufacturer's recommended service schedule.

Engine oil capacity is 1.2 qt (1.14L) without a filter change and 1.5qt (1.42L) with a filter change.

### ⚠ WARNING



- State and federal agencies have determined that contact with used engine oil can cause cancer or reproductive toxicity. Take care to limit skin contact and breathing of vapors as much as possible. Use rubber gloves and wash exposed skin.

### ⚠ CAUTION

- Too much oil can cause high oil consumption, high operating temperatures and oil foaming. Too little oil can cause severe engine damage. Keep the oil level between the full and add marks on the dipstick.
- Any attempt to crank or start the engine before it has been properly serviced with the recommended oil will result in an engine failure that is not covered under warranty.
- Never run this equipment without the complete air cleaner system installed on the engine. Failure to do so will result in premature engine wear and significantly reduced engine life.

## FIRST TIME STARTUP

After completing all installation procedures, read and understand the operating instructions for the generator controller. Know how the control panel operates, what to expect when activating control panel switches and how to shut the generator off in the event of an emergency. Before starting the generator for the first time, check off all items on the following list, then follow the given procedure to verify correct operation of the generator.

- Is unit level?
- Is adequate free air space (3 feet minimum or greater, *check your local building codes for clearance requirements for your area.*) available on all sides of the enclosure?
- Are all cabinet openings free from blockage?
- Is the exhaust directed away from dwellings, dwelling air intakes, or combustible materials?
- Are the fuel supply lines and internal generator fuel connections leak-free?
- Is fuel supply pressure within specifications?
- Is the regulator connection properly configured for the fuel supplied?
- Is an approved transfer switch used to prevent backfeed into utility lines?
- Are electrical connections tight, and properly connected?
- Are electrical conductors sized properly?
- Is a properly sized engine cranking battery correctly installed?
- Is the battery maintenance charger plugged in and operating correctly?
- Are all protective covers installed and tightened?
- Are all tools clear of moving or electrically live parts?
- Is the installation inspected and approved as required by local or regional code?

Once all items on the checklist are marked off, complete the initial startup using the listed steps.

## DANGER



- **Contact with high voltages present in generators and utility systems can cause severe electric shock or death. Avoid contact with all live components.**
- **Allow only qualified generator service technicians or licensed electrician's to perform initial system start-up.**

1. Press the OFF button on the control panel of the generator.
2. Move the main line circuit breaker handle on the generator to the OFF position.
3. Check the utility, or preferred, power supply to the transfer switch following the instructions provided by the switch manufacturer.
4. Ensure utility power to the transfer switch is shut off.
5. Return to the generator and open any manual shutoff

valves in the fuel supply system.

6. Press the MANUAL button on the control panel. The generator should crank and start.
7. Allow the generator to run for approximately three (3) minutes, then move the main line circuit breaker handle to the ON position.

## DANGER



- **Generator is now supplying dangerous voltages. Use extreme caution performing electrical checks.**

8. Check across the circuit breaker of the main line power output block (Red to Black) for proper frequency and voltage. Frequency should read approximately 62.5 Hz and voltage between 240 and 245 volts at no load conditions.
9. Adjust no load speed as required to meet approximately 62.5 Hz.
10. Shut the generator down by pressing the OFF button on the control panel.
11. Restore utility power to the transfer switch.
12. Press the AUTO button on the control panel to set the generator to automatic.
13. Inspect the site to ensure no packaging or installation materials remain within or against the generator.
14. Replace all covers on the generator.
15. Place the generator into service by pressing the AUTO button on the control panel.

## CAUTION

- **Failure to set the controller to AUTO before leaving the generator renders the generator unavailable for automatic standby service.**

## GENERATOR OPERATION

A standby generator is an engine driven air cooled system to convert the energy contained in either liquid propane vapor or natural gas to electrical power. When coupled with an automatic transfer switch to monitor for failure of utility power, the unattended system can start, stop and transfer between sources to insure a nearly seamless supply of power. The generator is housed in a weather resistant, sound attenuated enclosure for outdoor installation only.

Before installing and starting the generator, become familiar with the controls and operational features of the generator. Know how the control panel operates, what to expect when activating control panel switches and how to shut the generator off in the event of an emergency.

## CONTROL PANEL FEATURES

- A. MODE BUTTONS (AUTO, MANUAL AND OFF)
- B. AUTO LED
- C. STATUS INDICATOR LED's
- D. UTILITY POWER MONITOR LED
- E. TRANSFER SWITCH MONITOR LED
- F. GENERATOR POWER MONITOR LED
- G. HOUR METER

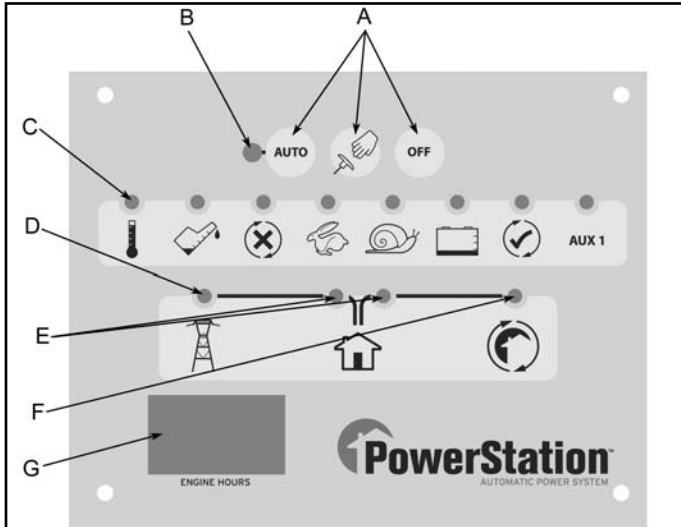

### A. Mode Buttons

The Mode Buttons are used to set the operating state of the generator. Pressing the OFF button prevents engine operation or stops the engine if it is already running. Pressing the MANUAL button (center button) immediately starts the generator. Pressing the AUTO button sets the generator for unattended operation under the control of properly matched automatic transfer switch.

## WARNING



- With the Mode in the auto position, the unit starts and stops without notice.
- Keep clear of all moving parts at all times.

### B. Auto LED

The Auto LED will be green when the controller is placed in the Auto Mode.

### C. Status Indicator LED's

Status Indicator LED's are provided to communicate the status of the generator to the user. Under normal running conditions, only the green Auto LED is lit. Function of all other LED's are described on page 21.

### D. Utility Power Monitor LED

The Utility Power Monitor LED will illuminate green when the Voltage Sensing detects that the Utility is available.

### E. Transfer Switch Monitor LED

The Transfer Switch Monitor LED will illuminate Green when the transfer switch is in the normal position and it will illuminate Red when the Transfer Switch is in

the Emergency position.

### F. Generator Power Monitor LED

The generator power monitor LED will illuminate Red when the Voltage Sensing detects that the Generator source is available.

### G. Generator Hour Meter

The Generator Hour Meter is provided to track the total numbers of hours of operation. The hour meter runs whenever the engine is running and the alternator is producing electricity. Placing the main line circuit breaker in the OFF position while the engine is running does not stop the meter from counting hours.

## CIRCUIT BREAKER

### Main Line Circuit Breaker

A Main Line Circuit Breaker is provided to protect the generator from damage caused by electrical faults within the attached electrical distribution system. It is also used to isolate the output of the generator from the connected electrical distribution system by moving the breaker handle to the OFF position. Placing the breaker in this position does not prevent startup of the generator.

## WARNING



- Place the circuit breaker in the OFF position when servicing the generator to minimize electrocution hazards.

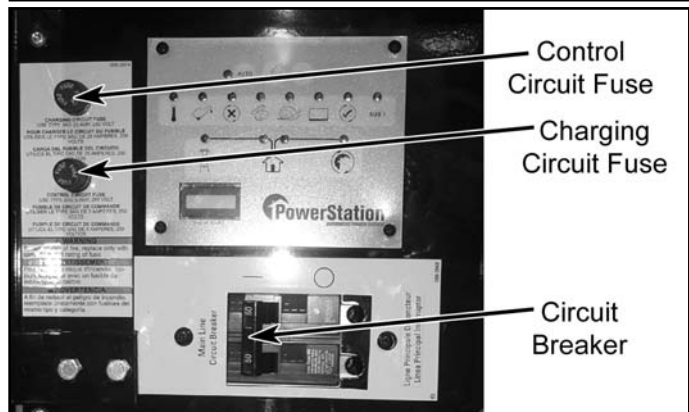

## FUSES

### Control Circuit Fuse

The Control Circuit Fuse provides protection against damage from electrical faults. Replace the fuse only with an equivalent size and style of fuse to prevent damage to the control system.

### Charging Circuit Fuse

The Charging Circuit Fuse provides protection to the engine mounted alternator in the event of electrical faults in the positive (+) battery circuit. Failure of this fuse prevents charge from reaching the battery when the generator is running, leading to early battery failure. Replace the fuse only with an equivalent size and style of fuse to prevent damage to the control system.

## GENERATOR CONTROL PANEL OPERATION

### RUN MODES

There are three run mode options: **Off**, **Manual** and **Auto**. When the **Manual** pushbutton is pressed the unit will immediately start and the run indicator light will illuminate. In **Manual** mode, the generator will continue to run until the **Off** pushbutton is pressed to stop the unit. At this point the “not in auto” light will illuminate and the unit will not operate.

When the **Auto** pushbutton is pressed the unit will enter automatic run mode, where the generator controller and the transfer switch will control the operation of the unit. In automatic run mode, the unit will automatically start up and shut off when power failure occurs and to exercise the unit.

### ⚠ WARNING



- **With the Mode in the Auto position, the unit starts and stops without notice.**
- **Keep clear of all moving parts at all times.**

When power failure occurs, a signal will be sent to the generator to start a warm up cycle. After the warm up cycle is completed, the transfer switch will allow the load to be transferred to the generator until it senses that regular utility power has been restored. When this occurs, the transfer switch will remove the load from the generator and a signal will be sent to the generator to begin a cool down cycle. After the cool down cycle is completed, the unit will stop running, but remain in the automatic run mode.

The unit will also automatically start itself to ensure it remains in good working order. Every 28 days the unit will automatically start up without warning and run for 20 minutes before shutting down. The unit will remain in automatic run mode after each exercise session.

### STARTING THE GENERATOR

Two methods are available to start the generator. The automatic, or AUTO mode is for use with an automatic transfer switch. With the control panel mode switch set to this position, the generator waits for an external signal to start. This signal is supplied by the transfer switch when utility power is of unacceptable quality. Since utility power can fail at any time, be aware **the generator can start unexpectedly whenever in the AUTO position. Keep away from moving parts at all times.** Once utility power is once again acceptable, the signal from the transfer switch is removed, the generator shuts off, then returns to waiting for another signal to start.

The other method for starting the generating is to press the MANUAL position mode button. This mode is

intended for generator control during maintenance or if an automatic transfer switch is not used. With the control panel switch shifted to this position, the generator will immediately attempt to start after a brief pause. Upon starting, the generator runs until the switch is moved from the MANUAL position, at which time the generator will shut off.

### CYCLIC CRANK

To insure the generator starts without damaging the starter motor, cranking of the engine is performed in a cyclic manner. When the generator is started from either the AUTO or MANUAL positions, the controller alternates between 10 seconds of engine cranking, followed by 10 seconds of engine rest. If the engine starts during any of the cranking periods, crank attempts are halted and the controller begins monitoring for proper function of the generator. In the event that three 10 second start attempts occur without the engine starting, cranking attempts are halted and the Overcrank light is lit.

### RUN STATE

After the engine is started and the generator is producing electrical power, the controller begins operation in a monitoring state. In this state, several generator functions are continuously checked to ensure proper operation of the generator. If functions are determined unacceptable, a fault is declared, the engine is shut down and a status light is lit to communicate the reason for the shutdown.

### SHUTDOWN

When operating with the control panel switch in the MANUAL position, the generator will continue to run until a fault is declared or until the mode switch is moved to the OFF position. Once the switch is shifted to the OFF position, the engine is shut off.

When operating with the control panel switch in the AUTO position, the generator continues to run until a fault light is declared or the run signal is removed. Once the signal is removed, the engine shuts down and the controller returns to waiting for a start signal.

## STATUS INDICATORS

Status indicator LED's relay conditions of generator function for user or service technician convenience. Illumination of these indicator LED's communicate conditions that require generator service but are not severe enough to cause damage if the generator is allowed to operate. Contact a qualified service technician immediately for service if any of the listed LED's are lit, even if the generator appears to function normally.

### LOW BATTERY

The Low Battery LED is will illuminate Red when the cranking battery voltage falls below 11.0 volts. At this level, the battery begins to lose the ability to consistently start the engine. Causes of low battery voltage may include a failing battery, failed battery charger or failed engine alternator.

### ENGINE RUN

The Engine Run LED illuminates Green when the generators engine is running. This is the only light lit when the generator is supplying power as intended.

## FAULTS

Fault lights relay conditions that may cause damage to the generator and/or loads connected to the output of the generator. When any of the listed situations occur while the generator is running, the generator is shut down and the fault light associated with the shutdown cause is lit. Once the light is lit, it remains on until it is cleared by pressing the OFF button on the control panel. If a fault light is lit, determine and correct the cause of the problem before restarting the generator. During generator starting, the controller ignores fault conditions until 15 seconds after the generator starts, then uncleared faults will once again cause the generator to shut off. To determine possible fault causes, refer to the troubleshooting section of this manual or contact a qualified service technician for assistance.

### HIGH TEMPERATURE

The High Temperature LED illuminates Red if the temperature of the engine becomes too high. Engine oil temperature is monitored while the engine is active and the engine is shut off to avoid damage if the oil temperature becomes too high. When operating the generator in temperatures above the maximum listed on the nameplate, it is necessary to reduce the load connected to the generator to avoid overheating. If high ambient temperatures or excessive loads are eliminated as possible causes of High Temperature shutdown, check to insure cabinet openings are not restricted by debris.

### LOW OIL

The Low Oil LED illuminates Red and the engine is shut off if the engine oil pressure falls

too low. To avoid engine damage, engine oil pressure is monitored to determine the amount of oil in the engine. When pressure falls below a preset level, a Low Oil fault occurs. Check for proper oil level if the generator shuts down due to a Low Oil alarm.

### OVERCRANK

The Overcrank LED is illuminated Red if all three 10 second cyclic crank attempts are unsuccessful in starting the engine. Once the light is on, the generator does not attempt to start until the fault is reset. When the Overcrank LED is lit, verify fuel is available at the inlet to the unit, then check the condition of the cranking battery.

### OVERSPEED

The Overspeed LED is illuminated Red if the generator engine is running too fast. Electrical output of the generator at high speeds may damage loads connected to the generator output and/or engine failure may occur at excessive speeds. If the generator shuts down on an Overspeed error, seek assistance from a qualified generator service technician.

### LOSS SPEED

The Loss Speed LED is illuminated Red if the generator engine is running too slow. Electrical output of the generator at low speeds can damage loads connected to the generator output and/or generator failure may occur due to excessive heating in the generator head. If the generator turns off due to an Loss Speed error, check to see that the connected loads do not exceed the nameplate rating of the generator.

### AUX 1

This is a common alarm, it flashes when there is a failure or alarm. A signal is sent to the transfer switch and illuminates the generator failure LED located on the transfer switch.

## MAINTENANCE

To ensure reliable generator operation, it is critical to periodically inspect all components. The following chart is provided as a guide for service check intervals. When the generator is operated under excessively hot, or dusty conditions, shorten service intervals according to the severity of the conditions encountered. To perform periodic inspections or maintenance, refer to the

procedures listed in the following sections. A qualified generator service technician should perform inspections or adjustments requiring specialized tools or training. Users unfamiliar with any of the listed procedures should contact an authorized dealer for servicing assistance.

Maintenance Item		Every month or 8 hours	Every 6 months or 100 hours	Every year or 300 hours	Every 2 years or 500 hours
Engine Oil	Check	X			
	Change		X <sup>1</sup>		
Engine Oil Filter	Change		X		
Oil Cooler	Check and clean		X		
Engine Air Filter	Check	X			
	Change			X	
Battery	Check and clean		X		
Battery Charger	Check		X		
Spark Plugs	Check			X	
	Replace				X
Valve Clearance	Check and Adjust			X	
Generator Output Frequency	Check and Adjust			X	
Fuel System	Check		X		
Cooling Air Openings	Check	X			

1. Perform first change at 25 hours.

## MAINTENANCE (cont.)

### ⚠ WARNING



- Before performing any maintenance, make sure the controller mode is in the OFF position, the circuit breaker is in the OFF position and the positive (red) battery cable is disconnected.
- Generator/engine components are hot to the touch when operating. To prevent burns to the skin allow unit to cool before touching internal generator or engine components.
- Crankcase pressure can blow hot engine oil out the fill opening causing severe burns. Always stop the generator before removing the oil fill cap.
- Keep hands, feet, clothing, etc., away from drive belts, fans, and other moving or hot parts. Never remove any drive belt or fan guard while the unit is operating.
- Generator output connections must be made by a qualified electrician in accordance with applicable codes.
- Engine heater (optional) can cause electrical shock. Remove engine heater plug from electrical outlet before working on heater connections.
- Improper service or replacement of parts can lead to severe personal injury or death and to damage to equipment and property. Service personnel must be qualified to perform electrical and mechanical service.
- Use caution when working on live electrical equipment. Remove jewelry, make sure clothing and shoes are dry and stand on a dry wooden platform.
- When performing a high voltage test, hazardous voltage can cause severe injury or death. Follow the instructions of the test equipment manufacturer when performing high-voltage tests on the rotor or stator. An improper test procedure can damage equipment or lead to generator set failure.
- State and federal agencies have determined that contact with used engine oil can cause cancer or reproductive toxicity. Take care to limit skin contact and breathing of vapors as much as possible. Use rubber gloves and wash exposed skin.
- The engine exhaust from this product contains chemicals known to the State of California to cause cancer, birth defects, or other reproductive harm.

## ENGINE OIL LEVEL CHECK

Prior to checking the oil level, start the generator by pressing the MANUAL Mode button on the control panel. Allow the generator to run for one or two minutes, then shut it down by pressing the OFF button on the control panel. After the engine comes to a stop let the engine set for a couple of minutes before checking the oil level. Begin the level check by removing the dipstick (B), wiping it clean, then reinserting it into the engine. Remove the dipstick a second time, checking that the oil level falls between the upper and lower limit marks on the end of the dipstick, as shown in Fig. A. Adjust engine oil level as required so the level is at the upper limit mark on the dipstick, adding oil to the engine through the oil fill cap (A) as shown in Fig B. Add only oil of the same specification as the oil already in the engine.

Fig. A

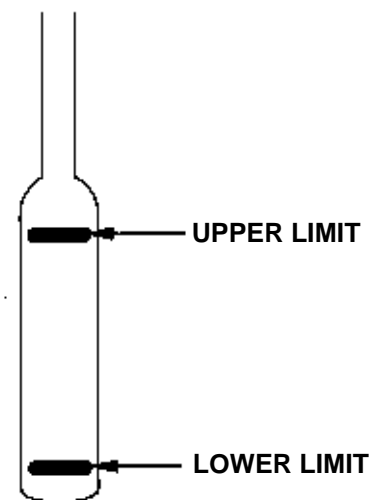
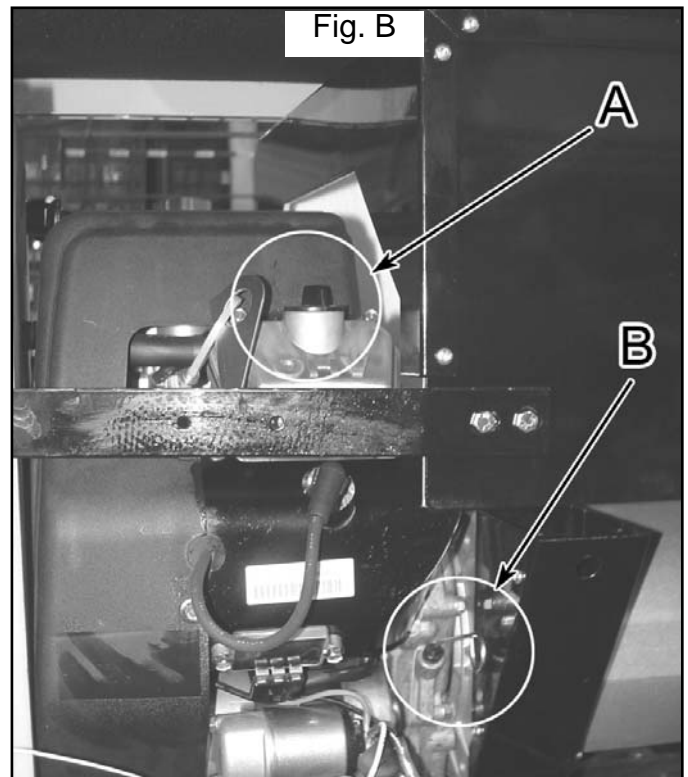

Fig. B



## ENGINE OIL AND OIL FILTER CHANGE

Selection of the correct grade and type of engine oil greatly affects the performance of the generator, especially when starting. Before selecting replacement oil for an oil change, consider the anticipated operating conditions the generator may be exposed to. Choose the appropriate weight of oil for anticipated temperatures from Chart C. If temperatures are expected to fluctuate between extremes prior to the next oil change interval, use of synthetic oil is recommended. Use of oil meeting a minimum American Petroleum Institute (API) classification of SJ is advised.

Chart C

										30	
		10W-30									
	5W-30										
°F	-20	0	20	40	60	80	100				
°C	-30	-20	-10	0	10	20	30	40			

### ⚠ WARNING



- State and federal agencies have determined that contact with used engine oil can cause cancer or reproductive toxicity. Take care to limit skin contact and breathing of vapors as much as possible. Use rubber gloves and wash exposed skin.

### ⚠ CAUTION

- Any attempt to crank or start the engine before it has been properly serviced with the recommended oil will result in an engine failure that is not covered by warranty.

Engine oil changes are recommended at the maximum intervals given in the Periodic Maintenance Table. When operating in hot or dusty conditions shorter change intervals may be necessary. To change the engine oil and oil filter, the listed procedure is recommended.

1. Warm up the engine oil by running a cold engine for a few minutes, then shutting it off. Start and stop the engine by pressing the MANUAL Mode button on the control panel to manually start the generator then press the OFF button to turn it off. Make sure that the generator is off by pressing the OFF button on

the control panel before continuing the oil change.

2. Place an oil drain pan under the oil drain plug (A).
3. Remove the drain plug (A) and place in a convenient location. Allow the engine oil to completely drain into the drain pan.
4. When the engine oil is completely drained, replace the oil drain plug (A) and tighten.
5. Place the drain pan underneath the spin on oil filter (B), then remove the filter by turning it counterclockwise. Once loose, drain all of the oil from the filter into the drain pan.
6. Apply a light film of oil to the gasket on the new oil filter, then screw the filter onto the adaptor until the gasket lightly touches the adaptor face. Tighten the filter an additional ¼ to 1 turn.
7. Refill the engine with new engine oil through the engine oil fill cap (C). Refer to the engine oil recommendations on chart C for the proper grade of oil and the specifications on page 6 for the oil capacity. Replace the oil fill cap (C), then start the engine and check for leaks.
8. Stop the engine and check the engine oil level as outlined on page 23. Add oil as required to bring the oil to the proper level on the dipstick.

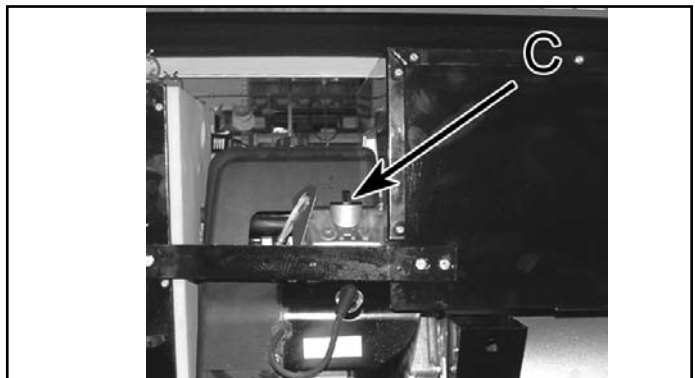
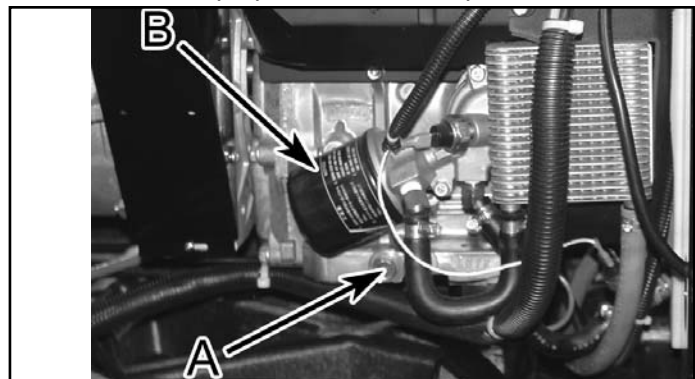

## ENGINE OIL COOLER INSPECTION AND CLEANING

At the intervals given in the maintenance schedule table, check the oil cooler and lines for leaks. If leaks are detected, replace clamps, fittings or hoses as necessary. Also visually inspect the oil cooler for debris clogging the cooler fins. If the cooler is blocked, use low pressure air or water to dislodge the blocking material.



## ENGINE AIR FILTER CHANGE

The generator engine is equipped with a dry element air filter to block particles in the combustion air from getting into the engine and causing excessive engine wear. Over time this dirt builds-up on the filter, restricting the amount of combustion air available to the engine, in turn leading to a loss of generator power output. To avoid these problems, periodic replacement of the engine air filter is recommended at the intervals outline in the service schedule table on page 22. To change the air filter, follow the listed steps.

### ⚠ CAUTION

- **Never run this equipment without the complete air filter installed on the engine. Failure to do so will result in premature engine wear and significantly reduced engine life.**

1. Remove the air filter cover (A) by turning the air filter cover nut (B) counterclockwise.
2. Remove the air filter (C).
3. Place a new air filter back onto the center stud.
4. Replace the air filter cover and air filter nut and tighten.

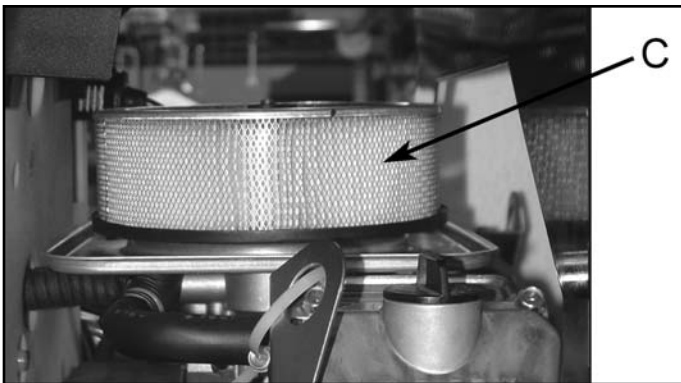
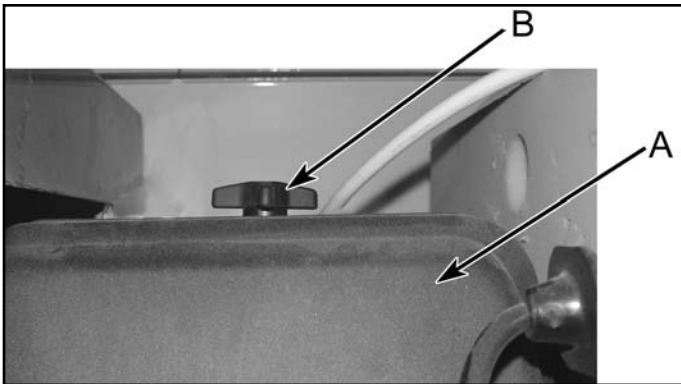

## BATTERY MAINTENANCE

### ⚠ WARNING



- **Read and understand all warnings and cautions on page 16 of this manual before proceeding with any battery maintenance.**

Correctly maintaining the battery at regular intervals is vital to ensure consistent engine starting. Poorly maintained batteries loose charge over time and may not provide enough power to crank the engine fast enough for reliable starts. The steps below are suggested to care for the battery and charger.

1. Keep the battery cable clamps (D) at the battery posts tight and free of corrosion. Replace the battery cables if cracks are found in the clamps.
3. Check and adjust the level of battery electrolyte according to the battery manufacturer's instructions if not using a "maintenance-free" battery. If electrolyte is low, add only distilled water to the battery. Do not add tap water to the battery.
4. Insure the battery charger (E) is powered and functioning properly. A correctly operating battery charger displays lights on the face of the charger to relay the state of the charger. Refer to Table A on page 26 to assess the mode the charger is operating in.

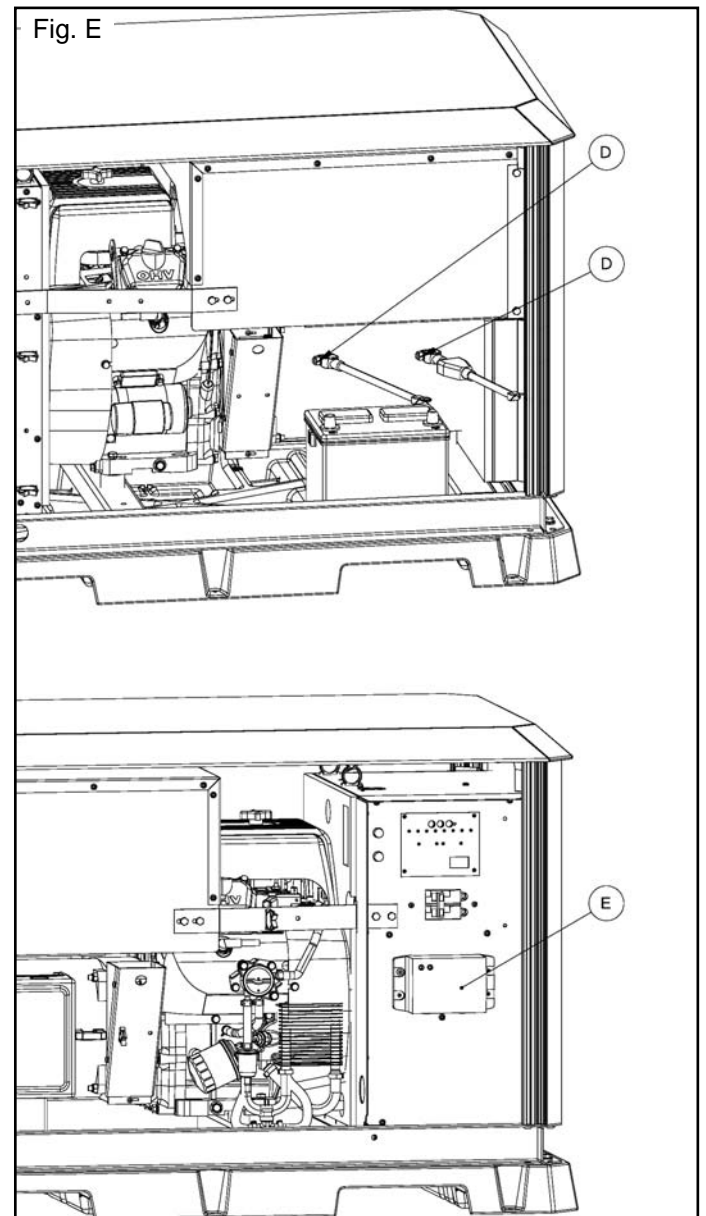

## BATTERY MAINTENANCE (cont.)

**Table A**

Display		Operating Condition
Red		•When the red LED is on, it indicates that your battery is discharged and the charger is recharging at the "BULK" rate of 6 Amps. •While the red LED is on, the voltage measured will be 11.8 to 14 volts. •If the red LED stays on for more than 24 hours, refer to the troubleshooting section of this manual.
Green		•When both the green and the red LED's are on, the charger is charging at an "ABSORPTION" rate of between 1.5 and 5 Amps. This mode of charging gradually "tops off" the battery, and reduces harmful sulfating. •While both LED's are on, the voltage measured should be approx. 14.0 to 14.5VDC. •If both LED's stay on longer than 24 hours, refer to the troubleshooting section in this manual.
Red		•When both the green and the red LED's are on, the charger is charging at an "ABSORPTION" rate of between 1.5 and 5 Amps. This mode of charging gradually "tops off" the battery, and reduces harmful sulfating. •While both LED's are on, the voltage measured should be approx. 14.0 to 14.5VDC. •If both LED's stay on longer than 24 hours, refer to the troubleshooting section in this manual.
Green		•When both the green and the red LED's are on, the charger is charging at an "ABSORPTION" rate of between 1.5 and 5 Amps. This mode of charging gradually "tops off" the battery, and reduces harmful sulfating. •While both LED's are on, the voltage measured should be approx. 14.0 to 14.5VDC. •If both LED's stay on longer than 24 hours, refer to the troubleshooting section in this manual.
Red		•When the green LED is on, the charger is charging at a "FLOAT" rate of less than 1.5 Amps. •This "float" charging current will gradually decrease to as low as 0.1 Amps as the battery reaches 100% charge. It will now be kept at full charge without over-charging. •If the green LED stays on when the battery is known to be low, refer to the troubleshooting section of this manual.
Green		•When the green LED is on, the charger is charging at a "FLOAT" rate of less than 1.5 Amps. •This "float" charging current will gradually decrease to as low as 0.1 Amps as the battery reaches 100% charge. It will now be kept at full charge without over-charging. •If the green LED stays on when the battery is known to be low, refer to the troubleshooting section of this manual.

## SPARK PLUG CHECK

Engine spark plugs are an important part of the engine ignition system. Worn or incorrectly adjusted spark plugs can negatively affect engine starting and operation. Therefore, it is important to inspect and regap, or replace the engine spark plugs as indicated in the service interval table. The listed steps are recommended to access and service the engine spark plugs.

### WARNING



- **Before performing any maintenance, make sure the Mode switch is in the OFF position, the circuit breaker is in the OFF position and the positive (red) battery cable is disconnected.**

1. Access the spark plugs by removing the front and back generator panels. Insert the key into the top locks and turn 1/4 turn counterclockwise to unlock. Lift the panels up and out of the base and set them aside.
2. Pull the spark plug boots loose, then clean any dirt from the area around the spark plugs. Remove the spark plugs with a 13/16" spark plug wrench.

3. Inspect the spark plugs for fouling or abnormal wear like excessively worn electrodes or cracked or chipped insulator material. If abnormal wear is indicated, replace the spark plugs. Fouled plugs indicate the need for engine service by a qualified engine service technician.  
New spark plugs or plugs that do not display any abnormal characteristics should be checked for proper gap using a suitable spark plug gauge. Adjust the gap to .035 inches (.889 mm) by carefully bending the grounding electrode.
4. Reinstall the spark plugs by hand until they begin to seat to avoid cross-threading. After the plugs begin to seat, tighten plugs an additional 1/4 turn with a 13/16" spark plug wrench to avoid damage to the spark plugs. If a torque wrench is available, tighten all plugs to **13 in-lbs (18 N-m)**.
5. Reassemble the front and back panels to the generator by setting the bottom end of the panel into the base and push into place. Insert the key into the top locks and turn 1/4 turn clockwise to lock.

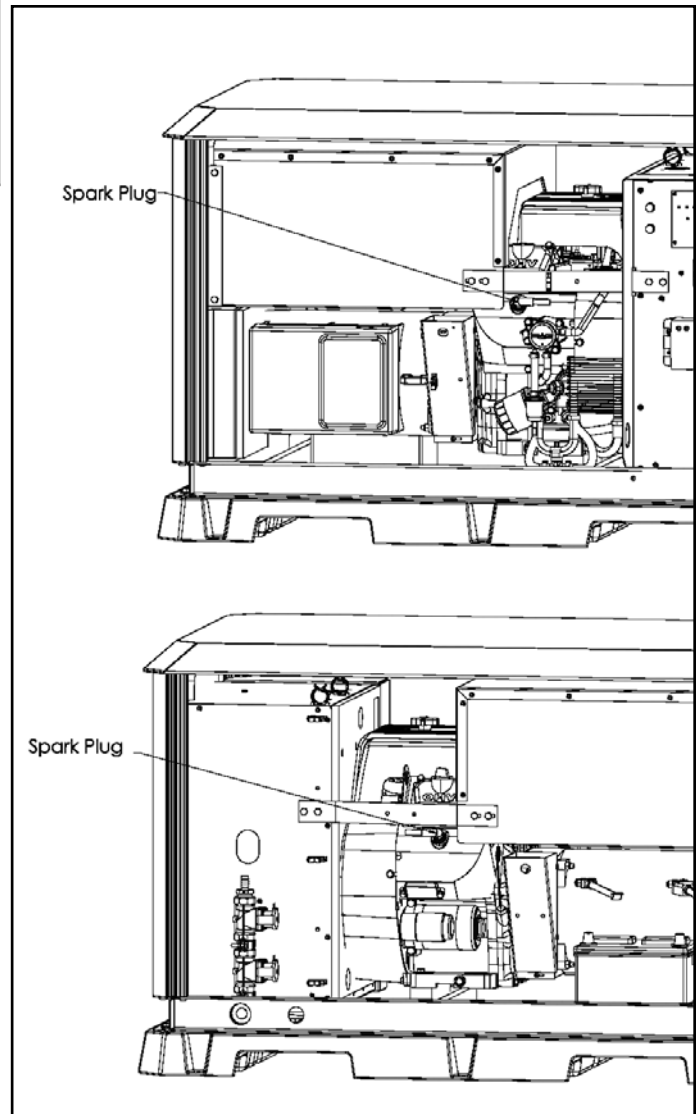

## ENCLOSURE AND SITE

Proper cooling of the generator is vital to maintain performance and prevent equipment failure. Blocked cabinet openings or other airflow obstructions are potential fire hazards and can cause failures. Periodically inspect generator cabinet openings and the engine oil cooler for blockages. Do not allow leaves, grass, dirt, snow or other objects to build up around the cabinet. Keep plants and other landscaping groomed to allow a minimum of three feet or greater of open space around all sides of the generator (*check your local building codes for clearance requirements for your area*). **Do not place a cover over the generator.**

### DANGER



- Generator exhaust air contains carbon monoxide, a deadly odorless, colorless and tasteless gas. Breathing carbon monoxide causes severe nausea, fainting or death. Do not allow exhaust air to enter a building through windows, doors, air intakes or other means. Avoid breathing exhaust air while operating or servicing the generator set. The engine exhaust from this product contains chemicals known to the State of California to cause cancer, birth defects, or other reproductive harm.

### CAUTION

- Covering or restricting the air passages on the generator will cause the unit to overheat and may create a fire hazard. Do not allow snow or leaves to cover enclosure openings.
- Leave a three foot or greater open area around all sides of the unit. *Check your local building codes for clearance requirements for your area.* Do not plant trees or plants close to the unit.
- Unit should be located to prevent combustible material from accumulating against the generator.
- The generator **MUST** be installed outdoors.

## VALVE CLEARANCE CHECK AND ADJUSTMENT

Over time, normal engine operation leads to wear in the engine valve train which decreases generator output. To restore generator output, it is necessary to check and adjust the engine valve lash at regular intervals throughout the life of the engine. However, proper valve lash adjustments require specialized training and tools. Adjustment by persons unfamiliar with the procedure can cause damage to the engine not covered under warranty. Contact an authorized generator dealer for assistance in locating qualified service personnel.

### CAUTION

- This adjustment should only be performed by trained personnel. If incorrect adjustments are made, the unit may fail to operate or operate inefficiently.

## FUEL SYSTEM INSPECTION

Avoid explosive and potentially lethal fuel leaks by inspecting the complete generator fuel supply system at intervals no greater than those listed in the Maintenance Table on page 22. Visually inspect all hoses for cracks, splits, or brittleness and replace hoses that show these or other signs of wear. Check all connections for tightness and cracks, replacing any broken fittings or clamps. Check all connections for leaks, while the generator is running, using approved equipment and methods. **DO NOT** use a flame to check for leaks.

### WARNING



- Extreme caution should be taken while performing general maintenance.
- Do not smoke when near the unit.
- Keep flames, sparks, pilot lights, arc-producing equipment, switches and all other sources of ignition well away. Keep a type ABC fire extinguisher handy.
- Do Not operate engine if smell of fuel is present or other explosive conditions exist.
- Do Not use a flame to check for leaks.

## TROUBLESHOOTING

SYMPTOM	POSSIBLE CAUSE	CORRECTIVE ACTION		
Engine does not crank	Loose battery cables	<ul style="list-style-type: none"> <li>• Check all battery cable connections.</li> </ul>		
	Defective battery	<ul style="list-style-type: none"> <li>• Test battery. Replace as necessary.</li> </ul>		
	Improper battery charger function	<ul style="list-style-type: none"> <li>• Ensure charger is plugged into receptacle.</li> <li>• Check for tripped main circuit. Reset if required.</li> <li>• Check all charger cable connections for cleanness and tightness.</li> <li>• Check charger lights to verify correct operation. See Table A, Page 26.</li> </ul>		
		Fault in starter signal circuit	<ul style="list-style-type: none"> <li>• Contact a qualified generator dealer for service assistance.</li> </ul>	
		Blown control circuit fuse	<ul style="list-style-type: none"> <li>• Check control circuit fuse.</li> </ul>	
	Engine cranks without starting	Low battery	<ul style="list-style-type: none"> <li>• Test battery. Replace as necessary.</li> <li>• Ensure charger is plugged into receptacle.</li> <li>• Check for tripped main circuit breaker. Reset if required.</li> <li>• Check all charger cable connections for cleanness and tightness.</li> <li>• Check charger lights to verify correct operation. See Table A, Page 26.</li> </ul>	
Poor fuel supply			<ul style="list-style-type: none"> <li>• Ensure all manual shutoff valves are open.</li> <li>• Check for proper fuel supply pressure.</li> <li>• Verify size and fill level of propane tank (LPG only).</li> <li>• Check fuel solenoid voltage during cranking.</li> </ul>	
			Low oil pressure	<ul style="list-style-type: none"> <li>• Check engine oil level.</li> <li>• Check switch for proper function.</li> </ul>
				High engine temperature
No generator output			Main line circuit breaker tripped	
		Disconnect breaker tripped	<ul style="list-style-type: none"> <li>• Check for tripped breaker in circuit between generator output and transfer switch. Clear fault, then reclose breaker.</li> </ul>	
		Generator loss of excitation	<ul style="list-style-type: none"> <li>• Contact a qualified generator dealer for service assistance.</li> </ul>	
		Excitation capacitor failure	<ul style="list-style-type: none"> <li>• Contact a qualified generator dealer for service assistance.</li> </ul>	
	Generator diode or varistor failure	<ul style="list-style-type: none"> <li>• Contact a qualified generator dealer for service assistance.</li> </ul>		
	Generator head fault	<ul style="list-style-type: none"> <li>• Contact a qualified generator dealer for service assistance.</li> </ul>		

## TROUBLESHOOTING

SYMPTOM	POSSIBLE CAUSE	CORRECTIVE ACTION
Low generator output voltage	Excitation capacitor failure	• Contact a qualified generator dealer for service assistance.
	Generator diode or varistor failure	• Contact a qualified generator dealer for service assistance.
Overspeed LED stays lit	Shutdown due to high engine speed	• Verify correct engine speed setting.
Low Speed LED stays lit	Shutdown due to low engine speed	• Reduce loads connected to generator.
Overcrank light stays lit	Failure to start	• See "Engine cranks without starting".
Low oil pressure LED stays lit	Shutdown due to low engine oil pressure	• Check engine oil level.
		• Verify correct type of engine oil for ambient temperature conditions.
Low battery LED stays lit	Low battery	• Test battery. Replace as necessary.
		• Ensure charger is plugged into receptacle.
		• Check for tripped main circuit breaker. Reset if required.
		• Check all charger cable connections for cleanliness and tightness.
		• Check battery charger inline fuse.
		• Check charger lights to verify correct operation. See Table A, Page 26.
High temperature LED stays lit	Shutdown due to high engine temperature	• Allow engine to cool, then restart.
		• Decrease loads on generator.
		• Check enclosure openings for blockage.



# POWERSTATION<sup>®</sup> Automated Power System Limited Warranty

**Warranty:** Powermate Corporation warrants to the original consumer purchaser in the U.S. or Canada that it will repair or replace any parts or components found to be defective in material or workmanship. The product must be properly installed and maintained in accordance with operator's manuals, and must be used solely as emergency stand-by power to a utility-supplied primary power system. Warranty service must be performed by an authorized service center.

**Warranty Period:**

*Comprehensive:* Covers the entire unit (including engine and alternator) for three (3) years or 1500 hours of operation, whichever occurs first, from the date of purchase. This warranty covers the cost of parts and labor to repair or replace defective parts.

*Extended Warranty on Engine/Alternator:* Covers the engine and alternator for five (5) years or 1500 hours of operation, whichever occurs first, from the date of purchase. If repair or replacement of defective engine/alternator parts or components is needed after the first three years, Powermate will provide or pay for the replacement parts or components. (Labor not included.)

For warranty service, the customer must provide dated proof of purchase and must notify Powermate within the warranty period. This warranty is not transferable.

**Not Covered:** The following are not covered by the warranty:

- Routine maintenance and tune-ups; replacement of normal maintenance items such as filters, spark plugs, fuses, or lamps; or consumables such as fuel, oil or coolant/antifreeze;
- Starting batteries, or service associated with battery failure;
- Damages or repairs caused by:
  - ~ Improper installation
  - ~ Improper maintenance, or failure to maintain and service the product according to the operating instructions
  - ~ Operation with improper fuels or lubricants, or at speeds, loads, or conditions contrary to operating instructions
  - ~ Abuse, accident, theft, vandalism, acts of God or other external causes;
- Overtime charges during repair or air freight shipping charges incurred at the customer's request, unless done with Powermate's prior approval.

Warranty is void (i) if the product is modified or altered contrary to published specifications, (ii) if repairs are performed by anyone other than Powermate-authorized service center or with parts other than Powermate-approved parts, or (ii) where the generator is used as a primary power source or as back up for solar, wind-power or other alternative power system.

**For warranty service: Call toll free 866-769-3703, or write to Powermate Corporation, Product Services, 4970 Airport Road, Kearney, NE 68848.**

**EXCLUSIONS AND LIMITATIONS:** THE COMPANY MAKES NO OTHER WARRANTY OF ANY KIND, EXPRESS OR IMPLIED. IMPLIED WARRANTIES, INCLUDING WARRANTIES OF MERCHANTABILITY AND OF FITNESS FOR A PARTICULAR PURPOSE, ARE HEREBY DISCLAIMED. THE WARRANTY SERVICE DESCRIBED ABOVE IS THE EXCLUSIVE REMEDY UNDER THIS WARRANTY; LIABILITY FOR INCIDENTAL AND CONSEQUENTIAL DAMAGES IS EXCLUDED TO THE EXTENT PERMITTED BY LAW.

This warranty gives you specific legal rights, and you may also have other rights which vary from state to state. Some states do not allow a disclaimer of implied warranties, or the exclusion or limitation of incidental and consequential damages, so the above disclaimers and exclusions may not apply to you.



**CONTACT THE POWERMATE PRODUCT SERVICE DEPARTMENT AT  
1-866-769-3703**

**to obtain warranty service information or to order replacement parts or accessories.**

### **HOW TO ORDER REPLACEMENT PARTS**

Even quality built equipment such as the Powermate standby generator you have purchased, might need occasional replacement parts to maintain it in good condition over the years. To order replacement parts, please give the following information:

1. Model No. and Serial No. and all specifications shown on the Model No./Serial No. plate.
2. A brief description of the trouble with the generator.

**Powermate Corporation  
4970 Airport Road  
P. O. Box 6001  
Kearney, NE 68848  
1-866-769-3703  
1-308-237-2181  
Fax 1-308-234-4187**

Made in USA with domestic and foreign components  
Powermate Corporation, Aurora, IL 60504  
©2007 Powermate Corporation

All Rights Reserved. Tous droits réservés. Reservados todos los derechos.

Powermate® is a registered trademark of Powermate Corporation.  
Powermate® est une marque déposée de Powermate Corporation.  
Powermate® es una marca comercial registrada de Powermate Corporation.

PowerStation® is a registered trademark of Powermate Corporation.  
PowerStation® est une marque déposée de Powermate Corporation.  
PowerStation® es una marca comercial registrada de Powermate Corporation.