

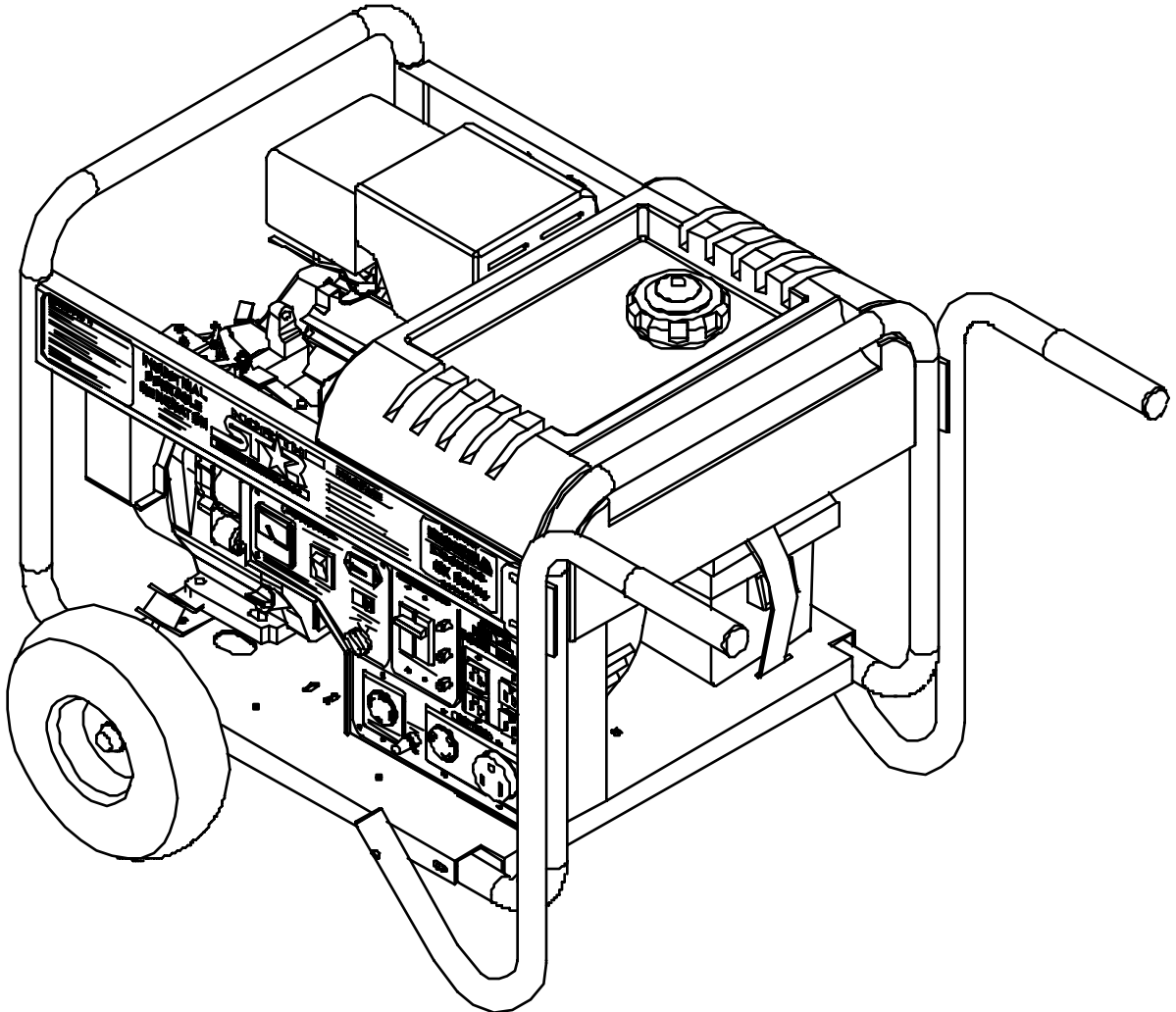

MODEL 5500 IPG, ITEM # 165926
Industrial Portable Generator

M165926A

OWNER'S MANUAL



5500 IPG

00219

Shown with Optional Wheel Kit (Item # 165916)

Any Questions, Comments, or Problems?
Call Customer Service at 1-800-270-0810
Hours: Monday - Friday 7:30 AM to 5:30 PM
Saturday 7:30 to 11:30 AM CST

THANK YOU

Thank you for purchasing a North Star Industrial Portable Series Generator. Your machine is designed for long life, dependability, and the top performance you demand. Please take time now to read through this manual so you can better understand the machine's operation, maintenance and safety precautions. Everyone who operates this generator must read and understand this manual. The time you take now will prolong your generator's life and prepare you for its safe operation. Enjoy the exceptional performance of your North Star Industrial Series Generator.

IMPORTANT

Make certain the operator:

- Reads and understands the manuals pertaining to this machine.
- Is instructed in safe and proper operation of this machine.

NOTICE

K-BAR Industries Incorporated reserves the right to make improvements in design and/or changes in specifications at any time without incurring any obligation to install them on units previously sold.

TABLE OF CONTENTS

Thank you	1
Specifications	2
Machine component identification	3
Generator features	4-5
Introduction	5
ANSI safety definitions	5
Rules for safe operation	5-6
Installation	6
Load application	6-8
Pre-start up preparation	8
Starting - Manual	9
Starting - Electric	9
Stopping	9
Engine care	9
Generator care	9
Troubleshooting	10

SPECIFICATIONS

Item Number	#165926
Maximum Output	5500 Watts (W)
Continuous Output	4500 Watts (W)
Voltage	120 / 240 Volt (V)
Phase	Single phase (4-wire)
Frequency	58.0-63.0 Hertz (Hz)
Power Factor	1.0 p.f.
Engine	9 HP Honda GX270
Engine Speed	3480-3780 RPM
Fuel Type	Unleaded gasoline
Fuel Capacity	6.5 gallons (24.6 L)
Oil Capacity	1.16 US quarts (1.1 L)
Starting Method	Electric Start / Recoil
120 V Receptacle	(2) 20 Amp (A) duplex GFCI (NEMA 5-20R) (1) 30 Amp (A) twistlock (NEMA L5-30R) (1) 50 Amp (A) Straight Blade (NEMA 5-50R)
120/240 V Receptacle	20 Amp (A) twistlock (NEMA L14-20R)
Circuit Breaker	(2) 20 Amp (A) Thermal, push to reset (1) 30 Amp (A) Thermal, push to reset (1) 20 Amp (A) Magnetic, 2 Pole
Grounding Post	Receives 10 Ga. wire or fork terminal
Dimensions	
Length	31.75" (80.6 cm)
Width	23.63" (60.0 cm)
Height	22.25" (56.5 cm)
Dry Weight	195 lb. (88.6 kg)
Gross Weight	240 lb. (109 kg)

MACHINE COMPONENT IDENTIFICATION

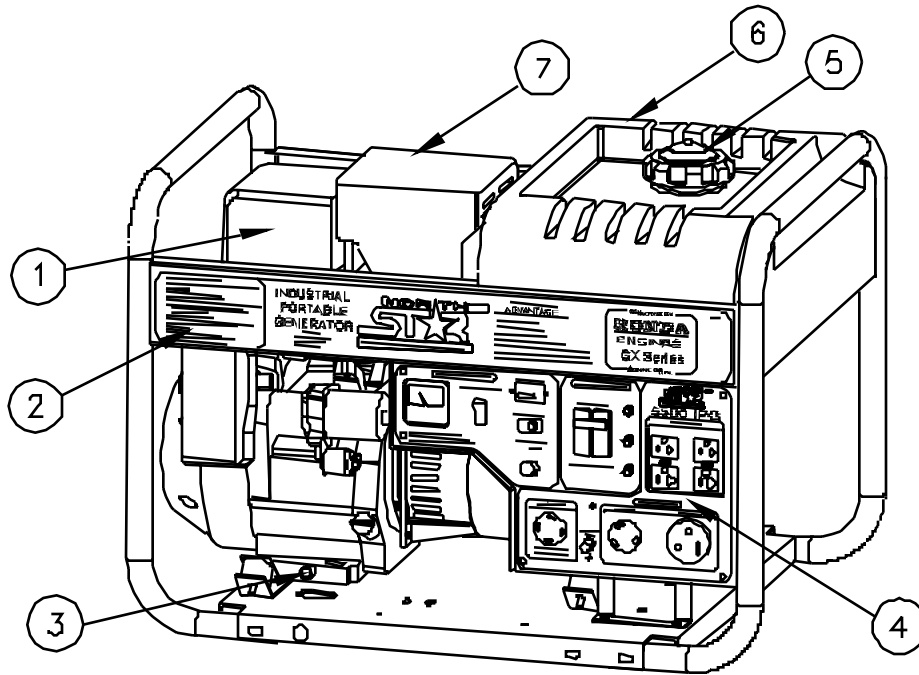

Figure 1 (Ref. 1-7)

00229

Ref.	Description	Ref.	Description
1	Air Cleaner	9	Gas Line Valve
2	Starting/Stopping Instructions	10	Generator Head
3	Oil Drain Plug	11	Battery & Box
4	Control Panel	12	Vibration Isolation Mount
5	Gas Cap with Gauge	13	Recoil
6	6.5 Gallon Gas Tank	14	Fuel Valve Lever
7	Super Silent Muffler	15	Choke Lever
8	Gas Drain Valve	16	Electric Stop/Start Switch

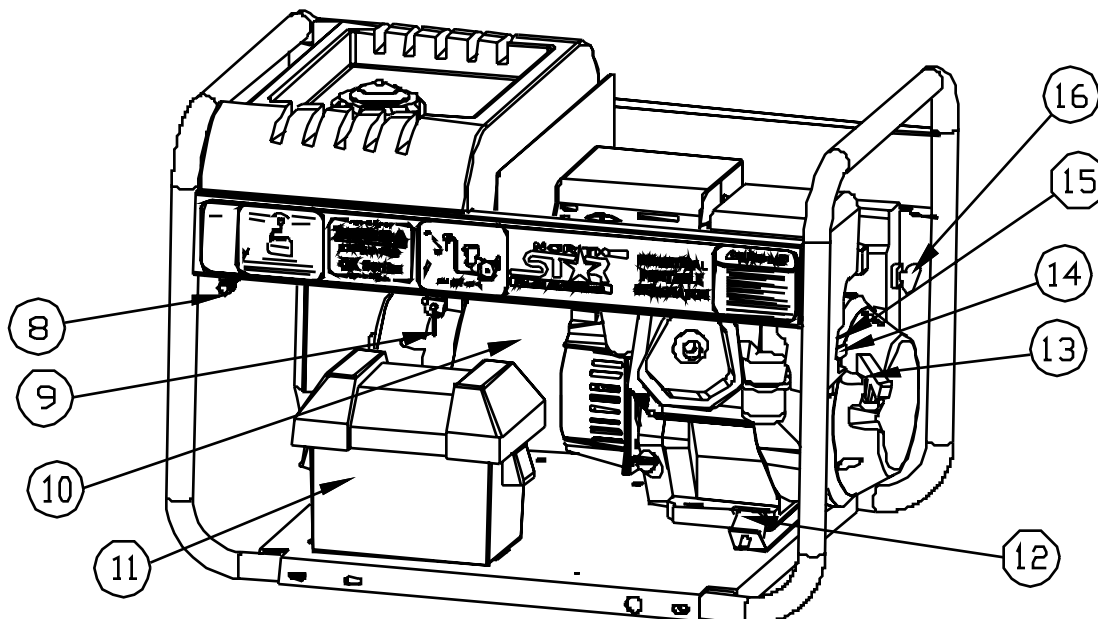

Figure 2 (Ref. 8-16)

00230

GENERATOR FEATURES

Reference 1 - Air Cleaner. Refer to your Honda engine manual for air cleaner care.

Reference 2 - Starting/Stopping Instructions.

Reference 3 - Oil Drain Plug. Refer to your Honda engine manual for oil change recommendations.

Reference 4 - Control Panel. See Fig. 3 for details.

Reference 5 - Gas Cap with Gauge. The gas cap is extra large, creating a large hole for refilling and a comfortable grip. You can always monitor the fuel level without removing the cap by using the fuel level indicator built into the gas cap.

Reference 6 - 6.5 Gallon Gas Tank. Large tank allows for extended run capabilities. **ALWAYS** allow room for gasoline expansion by not filling the gas tank completely full.

Reference 7 - Super Silent Muffler. 8 dB less than Honda's standard muffler. **NEVER** operate generator without the exhaust deflector attached in the upright position.

Reference 8 - Gas Drain Valve. The generator is equipped with a unique feature. A gas drain valve is installed to drain gasoline from the tank without disconnecting the gas line feeding the engine. This valve is intended to be used to drain gas prior to extended periods of non use. It is recommended that if the period of non use is longer than 30 days, the gas should be drained, and the engine ran until all the gas is evacuated from the carburetor. **ALWAYS** make sure this valve is closed prior to filling the gas tank.

Reference 9 - Gas Line Valve. The generator tank has an ON-OFF valve mounted underneath the tank. **ALWAYS** keep this valve closed when the generator is not in use or being transported.

Reference 10 - Generator Head. The electricity producing part of the generator.

Reference 11 - Battery and Box. The power source for electric starter.

Reference 12 - Vibration Isolation Mounts. The engine and generator head are mounted on rubber cylinders that absorb most of the engine vibration. This feature eliminates the tendency of the machine to "walk" which is common in engine powered equipment.

Reference 13 - Recoil. Grasp firmly when starting engine.

Reference 14 - Fuel Valve Lever. Additional valve for fuel shut off.

Reference 15 - Choke Lever. Used during cold starts. Refer to the starting/stopping instructions and the Honda engine manual for usage.

Reference 16 - Electric Start/Stop Switch. The engine key is located on the engine. Always locate this switch and be familiar with its location before operating the generator.

CONTROL PANEL IDENTIFICATION

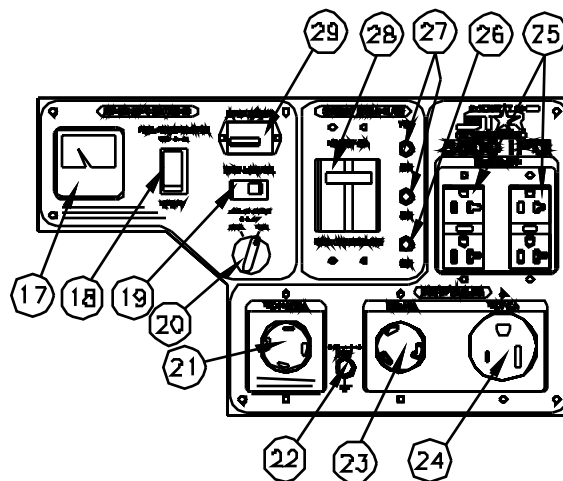

Figure 3 (Ref. 17-29)

00242

Ref.	Description
17	Voltmeter
18	Full Power Switch
19	Idle Control On/Off Switch
20	Adjustable Idle Delay
21	120/240V 20A Twistlock Receptacle
22	Grounding Post
23	120V 30A Twistlock Receptacle
24	120V 50A Straight Blade Receptacle
25	120V 20A GFCI Duplex Receptacle
26	30A Circuit Breaker
27	20A Circuit Breaker
28	Main Line Circuit Breaker 20A
29	Hour Meter

Reference 17 - Voltmeter. Voltmeter needle should be in green area during all generator load conditions.

Reference 18 - Full Power Switch. The switch reconnects the two generator windings from parallel (120V only) to series (120/240V).

- **120V Only:** Allows all 4500 watts (37.5A) to be used in any combination of 120 volt receptacles. The 120/240V receptacle is disabled.
- **120/240V :** Allows all 4500 watts to be used for 240V. However, only half the power or 2250 watts (18.8A), can be used at any one 120V receptacle. 120V output can total 4500 watts.

Reference 19 - Idle Control - On/Off Switch. This feature senses the load on the generator. With no load on the generator the engine speed drops to idle. This saves fuel and lengthens engine life. When a load is applied, the engine speed returns to 3600 RPM nominal. Turning the switch off disables the sensing device and the generator will run at 3600-3780 RPM whether or not a load is applied.

Reference 20 - Adjustable Idle Delay. Adjusts the amount of time from when the generator senses there is no load to when the generator actually idles down. The minimum delay is 5 seconds. The maximum is approximately 1 minute.

Reference 21 - 120/240V 20A Receptacle. One twistlock 120/240V receptacle capable of drawing 20 amps, (NEMA) number L14-20R. This receptacle accepts only NEMA 14-20P plugs, one of which is shipped with the generator. Use this receptacle if installing a transfer switch. Compatible with Gentran transfer switch, item #16411.

Reference 22 - Grounding Post. Ground the generator via the grounding post, to a copper pipe or rod that is driven down until it reaches moist soil.

References 23-25 - 120V Receptacles. The generator has a control panel with:

- **Reference 23** - two duplex (two receptacles in a common housing) 120V GFCI straight-blade receptacles capable of drawing 20 amp, National Electrical Manufacturer's Association (NEMA) part number 5-20R. These receptacles accept NEMA numbers 5-15P or 5-20P plugs.
- **Reference 24** - one straight-blade 120V receptacle capable of drawing 50 amp, NEMA 5-50R. This accepts only NEMA 5-50P plugs, one of which is shipped with the generator.
- **Reference 25** - one twistlock 120V receptacle capable of drawing 30 amps, (NEMA) number L5-30R. This receptacle accepts only NEMA number 5-30P plugs, one of which is shipped with the generator.

ALWAYS use grounded male plugs. The neutral line of the generator is mechanically grounded to the frame. Matching NEMA male plugs must always be used.



WARNING Contact a licensed electrician to wire electrical plugs and/or cordsets. Improper wiring could result in a fire or electrical shock. Never use defective or broken plugs or receptacles.

References 26-28 - Circuit Breakers. This portable single phase generator has

- **Reference 26** - (2) 20 amp (A) push-to-reset circuit breakers.
- **Reference 27** - (1) 30A push-to-reset circuit breaker
- **Reference 28** - (1) 20A magnetic 2 pole main circuit breaker to protect against electrical overloads.

Reference 29 - Hour Meter. Allows for a better maintenance schedule of the generator.

Low Oil Shutdown. The Honda engine is protected against damage resulting from low oil level. As the oil falls below the safe level, the engine automatically shuts off (the engine stop switch remains in the on position). The engine will not start until the oil is refilled to above the safe level.

INTRODUCTION

Before starting your generator, thoroughly study the instructions and cautions in this manual to assure you are fully acquainted with the operation of all components of this generator. Proper preparation, operation and maintenance will result in operator safety, best performance and long life of the generator. For detailed

engine operation and maintenance always refer to the Honda engine owner's manual furnished with the generator (Honda refers to the 9 HP engine as a GX270).

North Star is constantly improving its products. The specifications outlined herein are subject to change without prior notice or obligation. The purchaser and/or user assumes liability of any modification and/or alterations on this equipment from original design and manufacture.

Before using, the user shall determine the suitability of this product for its intended use and assumes liability therein.

ANSI SAFETY DEFINITIONS

DANGER indicates an imminently hazardous situation which, if not avoided, will result in death or serious injury. This signal word is to be limited to the most extreme situations.

WARNING indicates a potentially hazardous situation which, if not avoided, could result in a death or serious injury.

CAUTION indicates a potentially hazardous situation, which if not avoided, may result in minor or moderate injury. It may also be used to alert against unsafe practices.

RULES FOR SAFE OPERATIONS

Safety precautions are essential when operating this generator. Respectful and cautious operation will considerably lessen the possibilities of a personal injury. This manual will warn of specific personal injury potential, and these will be designated by the symbol:



WARNING This generator is equipped with a grounding post, located on the control panel for your protection. Always complete the grounding path from the generator to a copper pipe/rod that is driven into moist earth, to prevent electrical shock.

ALWAYS use electrical cords that are in good condition. Worn, bare, frayed or otherwise damaged cords can cause electric shock.

NEVER operate the generator, or handle any electrical equipment while standing in water, while barefoot, while hands are wet or while in the rain or snow. Electric shock may result.

ALWAYS use a ground fault circuit interrupter (GFCI) in damp or highly electrical conductive areas and on construction job-sites to prevent electric shock.

ALWAYS remove the spark plug or spark plug wire before working on the engine or generator, to prevent accidental starting.

ALWAYS provide adequate ventilation. Do not operate generator in any enclosed or narrow space. Engines consume oxygen and give off deadly carbon monoxide poisonous gas. Improper ventilation will cause damage to generator and possible injury to people.

NEVER touch hot muffler, hot exhaust manifold or engine cooling fins.

ALWAYS remove all oil or gasoline deposits and accumulated dirt from generator and immediate area. Keep generator head and engine clean.

NEVER operate the generator under the following conditions:

- A. Excessive change in engine speed, slow or fast.
- B. Overheating in load connecting devices.
- C. Sparking or arcs from generator.
- D. Loss of electrical output.
- E. Damaged receptacles.
- F. Engine misfire.
- G. Excessive vibration.
- H. Enclosed compartments, or confined areas.
- I. Flame or smoke.
- J. Rain, snow or wet conditions.
- K. Operator non-attendance.
- L. Excessive overload of generator.
- M. Wire with too small a gauge for the load.



WARNING Check fuel system on a regular basis. Look for signs of leaks, deterioration, chafed or spongy fuel hose, loose or missing fuel hose clamps, damaged fuel tank or a defective fuel shut-off valve. Correct any defects before operation.



WARNING Keep fire extinguisher close by your generator and be familiar on how to use it. Consult your local fire department for correct extinguisher type.

INSTALLATION

OUTDOORS: Choose a location where the generator will not be exposed to rain, snow or direct sunlight. Position the generator on secure, level ground so it will not tip or slide down a hill. Place the generator so that the exhaust fumes will not be directed towards people.

The installation site must be free from water, moisture, or dust. All electrical components should be protected from excessive moisture or the insulation system will deteriorate and result in grounding or shorting out the generating system.

Foreign matters, such as dust, dirt, sand, lint, or abrasive materials can cause damage to the generator head and engine if allowed into its cooling system.

NEVER install your generator inside confined areas. Inside installation can cause health hazards or death.



DANGER Remember, exhaust fumes are deadly carbon monoxide gas, and must be vented to the outside where there are no people. Cooling air of sufficient amounts must be allowed to flow in and exhausted out to ensure proper cooling of the engine and generator head.

LOAD APPLICATION

It is important to determine the total electrical load before it is connected to the generator. The two major factors in determining the life of a generator head are: heat build up, caused by overloading the generator and corrosive contaminants, that attack the wiring insulation. If the generator is overloaded, the wires become excessively hot and cause the insulation to break down, reducing its ability to resist corrosive contaminants. Over time the effectiveness of the insulation is eliminated and a dead short can result.

Always compare the generator nameplate data with that of the equipment to be used to ensure that watts, volts, amperage, and frequency requirements are suitable for operating equipment. The wattage listed on the equipment nameplate is its rated output. However, some equipment may require three to ten times more wattage than its rating on the nameplate, as the wattage is influenced by the equipment efficiency, power factor and starting system. **NOTE:** If wattage is not given on equipment nameplate, approximate wattage may be determined by multiplying nameplate voltage by nameplate amperage.

VOLTS X AMPS = WATTS

Example: 120V X 5A = 600W

When connecting a resistive load such as incandescent lights, heaters or common electric power tools, a capacity of up to the generator full rated wattage output can be used.

When connecting a resistive-inductive load such as a fluorescent or mercury light, transformers or inductive coils, a capacity of up to 0.6 times the generator's full rated output can be used.

Always allow the generator to reach operating speed before a load is applied.

STARTING ELECTRIC MOTORS

Electric motors require much more current (amps) to start than to run. Some motors, particularly low cost split-phase motors, are very hard to start and require 5 to 7 times more current to start than to run. Capacitor motors

are easier to start and usually require 2 to 4 times as much current to start than to run. Repulsion Induction motors are the easiest to start and require 1.5 to 2.5 times as much to start than to run.

Most fractional motors take about the same amount of current to run them whether they are of Repulsion-Induction (RI), Capacitor (Cap), or Split-Phase (SP) type. The following chart shows the approximate current required to start and run various types and sizes of 120 volt 60 cycle electric motors under various conditions.

120V, 60 Hz Motors		Starting Amps		
Hp motor	Running Watts	RI type	Cap type	SP type
1/6	525	7-11	9-18	16-22
1/4	700	9-15	12-23	22-32
1/3	875	11-18	14-29	26-35
1/2	1175	15-25	20-40	NA
1	1925	24-40	32-64	NA
1 1/2	2400	30-50	40-80	NA
2	2900	36-60	48-96	NA
3	4075	51-85	68-136	NA
5	6750	84-140	112-224	NA

The figures given above are for an average load such as a blower or fan. If the electric motor is connected to a hard starting load such as an air compressor, it will require more starting current. If it is connected to a light load or no load such as a power saw, it will require less starting current. The exact requirement will also vary with the brand or design of the motor.

Generators respond to severe overloading differently than the power line. When overloaded, the engine is not able to supply enough power to bring the electric motor up to operating speed. The generator responds to the high initial starting current, but the engine speed drops sharply. The overload may stall the engine. If allowed to operate at very low speeds, the electric motor starting winding will burn out in a short time. The generator head winding might also be damaged.

Running the generator under these conditions may result in damage to the generator stator as well as the motor windings. Because the heavy surge of current is required for only an instant, the generator will not be damaged if it can bring the motor up to speed in a few seconds. If difficulties in starting a motor are experienced, turn off all other electrical loads and if possible reduce the load on the electric motor.

EXTENSION CORDS

When electric power is to be provided to various loads at some distance from the generator, extension cords can be used. These cords should be sized to allow for distance in length and amperage so that the voltage drop between the set and point of use is held to a minimum.

Current/Power		Maximum Extension Cord Length			
Amps at 240V	Load (watts)	#10 Ga. Cord	#12 Ga. Cord	#14 Ga. Cord	#16 Ga. Cord
10	2400	250'	150'	100'	75'
20	4800	125'	75'	50'	25'
30	7200	60'	35'	25'	10'
40	9600	30'	15'	10'	*
50	12000	15'	*	*	*

*Not recommended

CAUTION: Equipment damage can result from the low voltage caused by using an extension cord with a small wire size.

Use this chart to estimate the total load on your generator.

For Determining Generator Load Requirements	
Device	Running Watts
Air Conditioner (12,000 Btu)	1700 (a)
Battery Charger (20 Amp)	500
Belt Sander (3")	1000
Chain Saw	1200
Circular Saw (6-1/2")	900
Coffee Maker	1000
Compressor (1 HP)	2000 (a)
Compressor (3/4 HP)	1800 (a)
Compressor (1/2 HP)	1400 (a)
Curling Iron	700
Dishwasher	1200
Edge Trimmer	500
Electric Nail Gun	1200
Electric Range (one element)	1500
Electric Skillet	1250
Freezer	800 (b)
Furnace Fan (1/3 HP)	1200 (a)
Hair Dryer	1200
Hand Drill (1")	1100
Hand Drill (1/2")	875
Hand Drill (3/8")	500
Hand Drill (1/4")	250
Hedge Trimmer	450
Home Computer	150
Impact Wrench	500
Jet Pump	800 (a)
Lawn Mower	1200
Light Bulb	100
Microwave Oven	700
Load Requirements Continued	
Milk Cooler	1100 (a)
Oil Burner on Furnace	300
Oil Fired Space Htr (140,000 Btu)	400
Oil Fired Space Htr (85,000 Btu)	225
Oil Fired Space Htr (30,000 Btu)	150
Oven	4500
Paint Sprayer, Airless (1/3 HP)	600 (a)
Paint Sprayer, Airless (handheld)	150
Radio	200
Refrigerator	600 (b)

Slow Cooker	200
Submersible Pump (1-1/2 HP)	2800 (a)
Submersible Pump (1 HP)	2000 (a)
Submersible Pump (1/2 HP)	1500 (a)
Sump Pump	600 (a)
Table Saw (10")	2000 (a)
Television	500
Toaster	1000
Vacuum cleaner	250
VCR	70
Water Heater	3000
Weed Trimmer	500

(a) Hard-starting motors require 3 to 5 times the rated running watts.

(b) These loads may require up to 15 minutes to restart due to its normal build up of compressor head pressure.

NOTE: For extremely hard to start loads such as air conditioners and air compressors, consult the equipment dealer to determine the maximum wattage.

PRE-START PREPARATIONS

Your generator has been thoroughly tested prior to shipment from the factory. A factory test report has been included with this manual. However, damage can occur during shipping, so be sure to check for damaged parts or loose or missing nuts and bolts. If the aforementioned problems occur, call Customer Service at 1-800-270-0810.

GROUNDING - All units must be grounded. Drive a 3/4" or 1" copper pipe or rod into the ground close to the generator. The pipe/rod must penetrate moist earth. Connect an approved ground clamp to the pipe. Run a no. 10 Ga. wire from the clamp to the generator grounding post located on the control panel. Do not connect to a water pipe or a ground used by a radio system.

CAUTION: The engine has been shipped without oil. Fill the crankcase with oil before trying to start. Low oil shut-down prevents your generator from starting without sufficient oil.

OPERATING SPEED

The generator must be run at the correct speed in order to produce the proper electrical voltage and frequency. The speed of the engine was carefully adjusted at the factory so that the generator produces the proper voltage and frequency.

The output voltage should be checked to ensure the generator is working properly before connecting a load to the generator. Failure to do so could result in damage to equipment plugged into the unit and possible injury to the individual.

All engines have a tendency to slow down when a load is applied. When the electrical load is connected to the

generator, the engine is more heavily loaded, and as a result the speed drops slightly. This slight decrease in speed, together with the voltage drop within the generator itself, results in a slightly lower voltage when the generator is loaded to its full capacity than when it is running with no load. The slight variation has no appreciable effect in the operation of motors, lights and most appliances. Electronic equipment and docks will be affected if correct RPM is not maintained. See Load vs. Output chart.

Load	Output		
	Speed (RPM)	Frequency (Hz)	Generator Voltage at 120V Receptacle
Percent of Generator Output			
0 %	3780	63.0	129V
50 %	3600	60.0	120V
100 %	3480	58.0	112V

Output voltage should be checked periodically to ensure continued proper operation of the generating plant and appliances, it can be checked with a portable meter. Frequency can be checked by using an electric dock with a sweep second hand. Timed against a wrist watch or a stop watch the dock should be correct within +/- 2 seconds per minute. All speed setting adjustments should be done by a qualified technician.

BEFORE STARTING

1. Make sure the generator is positioned on firm level surface.
2. Check the crankcase for oil and maintain at a proper level.
3. Check fuel level and fill tank with fresh unleaded gasoline. Never fill fuel tank completely to the top. Always wipe up and remove any spilled gasoline.
4. Make sure that the exhaust fumes are directed away from people.

STARTING - MANUAL

1. Disconnect all loads to generator.
2. Turn gas line valve to ON position.
3. Turn key to the ON position.
4. For cold engine, move choke lever to full choke position, for warm engine, move choke lever to half choke or to RUN position.
5. Firmly grasp recoil handle and pull.
6. When engine starts, move choke lever to RUN position.
7. Loads may now be connected to generator.

STARTING - ELECTRIC

1. Disconnect all loads to generator.
2. Turn gas line valve to ON position.
3. For cold engine, move choke lever to full choke position, for warm engine, move choke lever to half choke or to RUN position.
4. Turn key to start position.
5. When engine starts, move choke lever to RUN position.
6. Loads may now be connected to generator.

STOPPING

1. Disconnect all loads to generator.
2. Place key to the OFF position.
3. Turn gas line valve to OFF position.

ENGINE CARE

Refer to your Honda Owner's Manual for proper care and maintenance.

NOTE: When changing the oil on a hot engine, the oil might overshoot the oil drain hole on the generator base. Use a deflector (piece of cardboard or paper) to direct the oil down the hole.

GENERATOR CARE

The generator head is a two pole, 3600 RPM, 60 Hz, brushless, revolving field and synchronous type with one sealed ball bearing. The rotor of the generator head is directly connected to the engine crank shaft and the stator is rigidly coupled to the engine casting via the generator head casting.

Exercising The Generator - The generator should be operated every four weeks. This is accomplished by starting the engine and applying a load for 10 to 15 minutes. This will dry out any moisture that has accumulated in the windings. If left, this moisture can cause corrosion in the winding. Frequent operation of the engine generator will also ensure that the set is operating properly should it be needed in an emergency.

Generator Maintenance - The generator head is brushless and maintenance free. Any major generator service including the installation or replacement of parts should be performed only by a qualified electrical service technician. USE ONLY NORTHSTAR APPROVED REPAIR PARTS AVAILABLE AT 1-800-270-0810.

A. Bearing - The bearing used in these generators is a heavy duty sealed ball bearing. They require no maintenance or lubrication.

B. Receptacles - Quality receptacles have been utilized. If a receptacle should become cracked or otherwise damaged, replace it. Using cracked or damaged receptacles can be both dangerous to the operator and destructive to the equipment.



WARNING, Stand-by Operation

If your generator is to be used as a standby electric power source in case of utility failure, it must be installed by a registered and licensed electrician and in compliance with all applicable state and local electrical codes. Also, local Fire Departments must be consulted concerning proper and safe handling procedures for gasoline. **NEVER** connect any generator to any existing electrical system without an isolating, UL approved transfer switch, installed by a licensed electrician.

TROUBLESHOOTING

Problem	Possible Causes	Possible Remedies
Engine will not start.	<ul style="list-style-type: none"> a) Low oil level. b) Fouled spark plug. c) Out of fuel. d) Stop switch in OFF position. e) Battery has lost its charge. 	<ul style="list-style-type: none"> a) Fill crankcase to proper oil level. b) Clean or replace spark plug. c) Fill fuel tank. d) Place switch in ON position. e) Battery has low electrolyte and/or needs to be charged or replaced.
Voltage too low.	<ul style="list-style-type: none"> a) Engine speed too slow. b) Generator is overloaded. c) Idle control is malfunctioning. 	<ul style="list-style-type: none"> a) Bring generator to a qualified technician for adjustment. b) Reduce the load. (See Load Application section of this manual.) c) Bring generator to a qualified technician for inspection.
Circuit breaker trips.	<ul style="list-style-type: none"> a) Defective load connected to generator. b) Defective receptacle. c) Generator overloaded. 	<ul style="list-style-type: none"> a) Disconnect load. b) Replace receptacle. c) Reduce the load. (See Load Application section of this manual.)
Voltage too high.	<ul style="list-style-type: none"> a) Engine speed too high. 	<ul style="list-style-type: none"> a) Bring generator to a qualified technician for adjustment.
Generator overheating.	<ul style="list-style-type: none"> a) Generator is overloaded. b) Insufficient ventilation. 	<ul style="list-style-type: none"> a) Reduce the load. (See Load Application section of this manual.) b) Make sure there is at least 3 feet of clearance on all sides of generator.
No output voltage.	<ul style="list-style-type: none"> a) Defective load connected to generator. b) Broken or loose wire. c) Defective receptacle. d) Defective stator. e) Defective rotor. f) Defective capacitor. 	<ul style="list-style-type: none"> a) Disconnect load. b) Bring generator to a qualified technician for repair. c) Replace receptacle. d) Bring generator to a qualified technician for repair. e) Bring generator to a qualified technician for repair. f) Bring generator to a qualified technician for repair.
Engine lacks power.	<ul style="list-style-type: none"> a) Generator is overloaded. b) Dirty air filter. 	<ul style="list-style-type: none"> a) Reduce the load. (See Load Application section of this manual.) b) Clean or replace air filter.
Idle control doesn't work.	<ul style="list-style-type: none"> a) Switch is in OFF position. b) Solenoid failure. c) Defective circuit board. d) Defective capacitor. e) Circuit breaker tripped 	<ul style="list-style-type: none"> a) Place switch in ON position. b) Check for 24VDC at solenoid. Check coil resistance, it should be $73.9\Omega \pm 5\%$. Check for sticking in mechanism and solenoid. Replace idle assembly if necessary. c) Bring generator to a qualified technician for repair. d) Bring generator to a qualified technician for repair. e) Reset circuit breaker.
Engine shuts off during operation.	<ul style="list-style-type: none"> a) Out of fuel. b) Low oil level. 	<ul style="list-style-type: none"> a) Fill fuel tank. b) Fill crankcase to proper oil level.