

HONDA

PORTABLE GENERATOR

EG1000

OWNER'S MANUAL

This manual covers operation and maintenance of the EG1000 generator. All information in this publication is based on the latest product information available at the time of approval for printing. Honda Motor Co., Ltd. reserves the right to make changes at any time without notice and without incurring any obligation.

The manual should be considered a permanent part of the generator and remain with the generator when sold.

Read the manual carefully. Pay special attention to statements preceded by the following words:

WARNING

Indicates a possibility of personal injury or loss of life if instructions are not followed.

CAUTION

Indicates a possibility of equipment damage if instructions are not followed.

If a problem should arise, or if you have any questions about the generator, consult an authorized Honda dealer.

Thank you for purchasing a Honda Generator.

No part of this publication may be reproduced without written permission.

WARNING

The Honda generator is designed to give safe and dependable service if operated according to instructions. Read and understand the Owner's Manual before operating the generator. Failure to do so could result in personal injury or equipment damage.

CONTENTS

GENERATOR SAFETY	4
COMPONENT IDENTIFICATION	5
CONTROL BOX	7
OPERATION	8
GENERATOR USE	14
MAINTENANCE	16
TRANSPORTING/STORAGE	23
TROUBLESHOOTING	24
SPECIFICATIONS	25
WIRING DIAGRAM	26

GENERATOR SAFETY

WARNING

To ensure safe operation

- *Know how to stop the generator quickly and understand operation of all the controls. Never permit anyone to operate the generator without proper instruction.*
- *Keep children and pets away from the generator when in operation.*
- *The generator is a potential source of electrical shock when misused: Do not operate with wet hands. Do not operate in rain or snow.*



COMPONENT IDENTIFICATION

1. Fuel Filler Cap
2. Spark Plug Cap
3. Control Box
4. Engine Switch
5. Oil Filler Cap
6. Oil Drain Plug

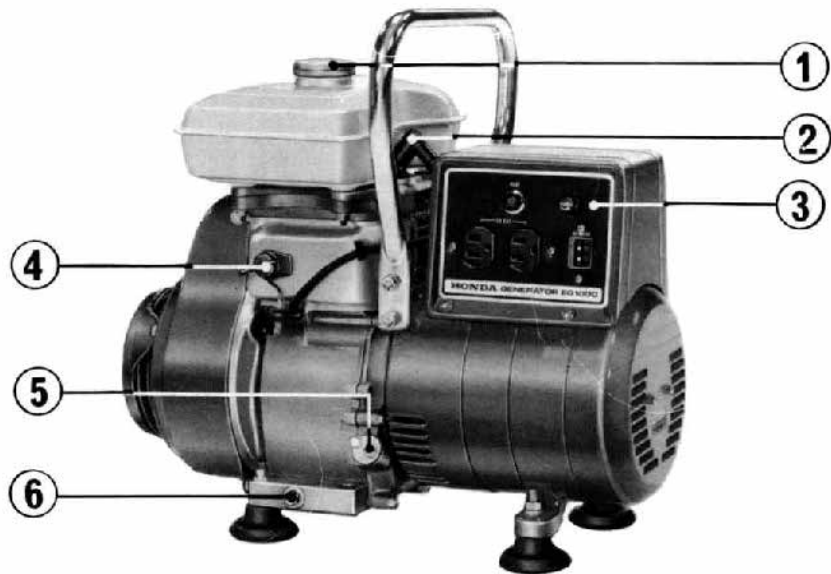

1. Choke Lever
2. Fuel Valve
3. Air Cleaner
4. Starter
5. Throttle Lever
6. Muffler
7. Frame

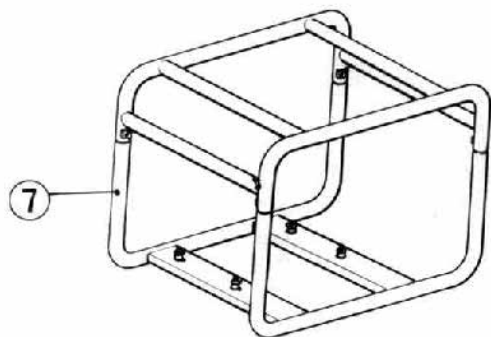

6-EG1000

CONTROL BOX

1. **PILOT LAMP.** Lights when the engine is running.
2. **FUSE HOLDER.** Houses a 8A fuse for the AC circuit.
3. **FREQUENCY METER.** Indicates generator frequency by oscillation.
4. **AC RECEPTACLES.** The maximum power available is 1.0 KVA (1,000 watts).
5. **DC OUTPUT TERMINALS.** The maximum power available is 100W (12V, 8.3A).
6. **FUSE HOLDER.** Houses a 15A fuse for the DC circuit.
7. **GROUND TERMINAL .**

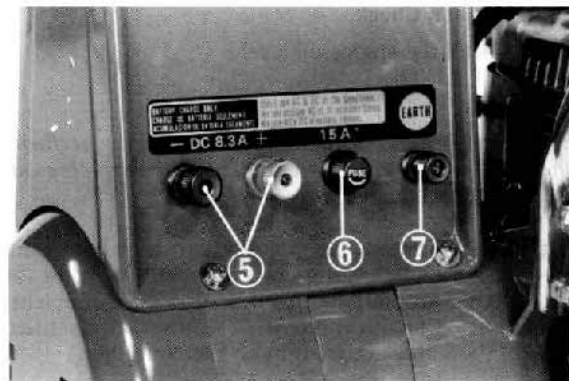

OPERATION

WARNING

- *Exhaust gas contains poisonous carbon monoxide. Never run the generator in an enclosed area. Be sure to provide adequate ventilation.*
- *Operate the generator on a level surface. If the generator is tilted, fuel spillage may result.*
- *Keep away from rotating parts while the generator is running.*

CAUTION

The generator is air-cooled and may be damaged if ventilation is inadequate.

Pre-Operation Check

1. Check the engine oil level.

CAUTION

Engine oil is a major factor affecting engine performance and service life. Non-detergent or vegetable oils are not recommended.

Use Honda 4-stroke, or an equivalent high detergent, premium quality motor oil certified to meet or exceed U.S. automobile manufacturer's requirements for Service Classification SE. (Motor oils classified SE will show this designation on the container.)

SAE 10W-40 is recommended for general, all-temperature use. If single viscosity oil is used, select the appropriate viscosity for the average temperature in your area.

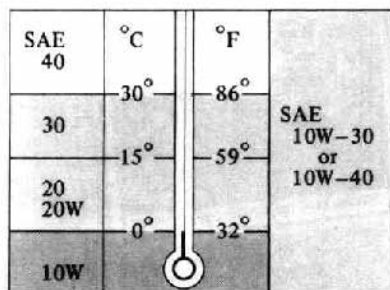

- A. With the generator on a level surface, remove the oil filler cap and check the oil level.
- B. If the level is below the lower limit, fill to the upper limit. Do not overfill; excess oil will result in power loss and smoking.

CAUTION

Running the engine with insufficient oil can cause serious engine damage.

- (1) Oil filler cap
- (2) Oil filler hole

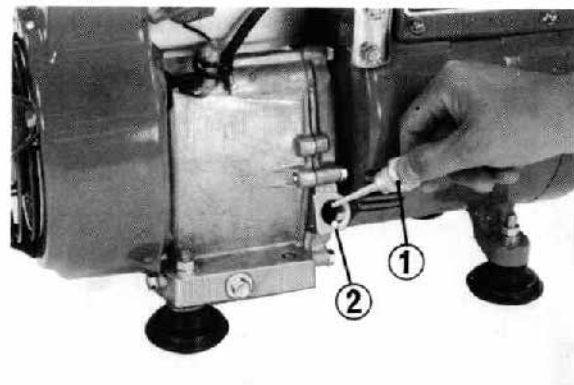

- (3) Upper limit
- (4) Lower limit

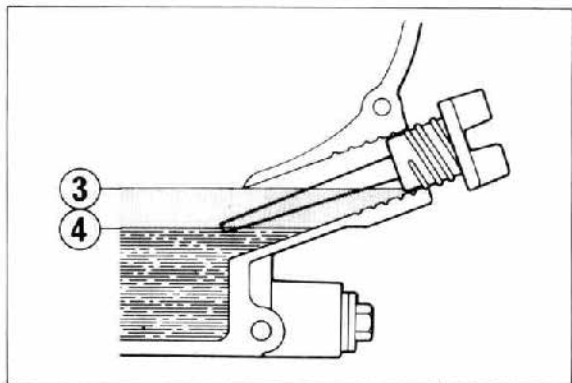

2. Check the fuel level

Use automotive gasoline with a research octane of 91 or higher or a pump octane ($\frac{R+M}{2}$) of 86 or higher.

Fill to half-way up the filler screen.

Never use an oil/gasoline mixture or dirty gasoline. Avoid getting dirt, dust or water in the fuel tank.

WARNING

- Gasoline is extremely flammable and explosive under certain conditions. Refuel in a well ventilated area with the engine stopped.
- Do not smoke or allow open flames or sparks in the area where the generator is refueled or where

(1) Fuel filler cap

(2) Fuel filler hole



gasoline is stored.

- Do not overfill the tank.
- Be careful not to spill fuel when refueling. Fuel vapor or spilled fuel may ignite. Wipe up any spilt gasoline and let the area dry before starting the engine.
- Make sure the filler cap is securely closed after refueling.

CAUTION

Gasoline substitutes, such as gasohol etc., are not recommended, they may be harmful to the fuel system components.

3. Disconnect any appliances. The generator may be difficult to start if a load is connected.



Starting the Engine

1. Turn the engine switch "ON" and turn the fuel valve to "ON".
2. Close the choke fully.

NOTE:

Do not use the choke if the engine is warm or if the air temperature is high.

(1) Engine switch

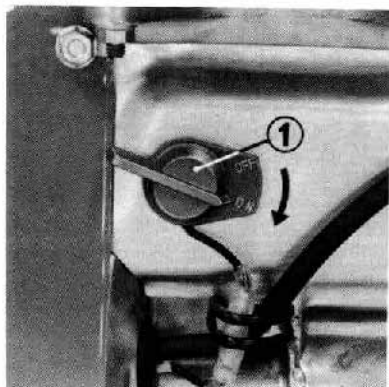

(2) Fuel valve
(3) "ON" position

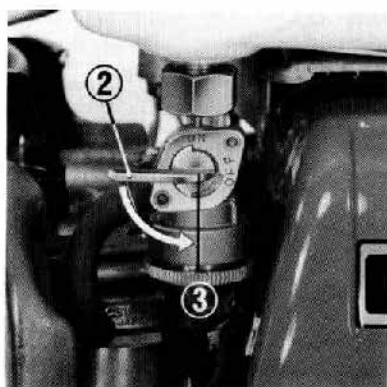

(4) Choke lever
(5) "CLOSE" position

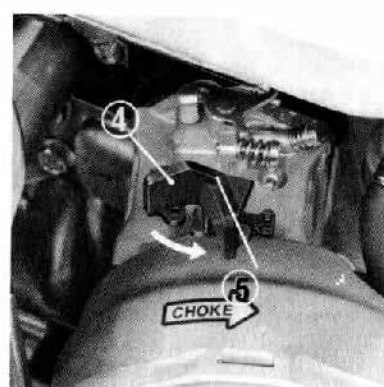

3. Raise the throttle lever slightly.
4. Pull the starter rope lightly until compression is felt, then pull briskly.
5. Open the choke as the engine warms up. Move the throttle to "NORMAL".

(1) Throttle lever

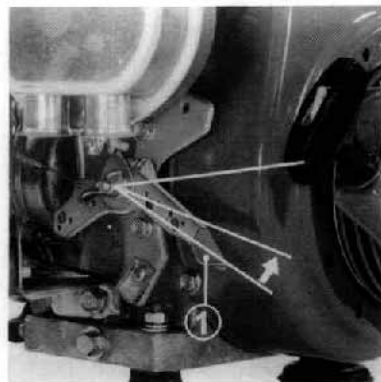

(2) Choke lever
(3) "OPEN" position

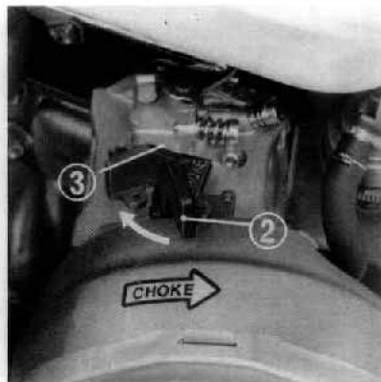

(4) Throttle lever
(5) "NORMAL" position

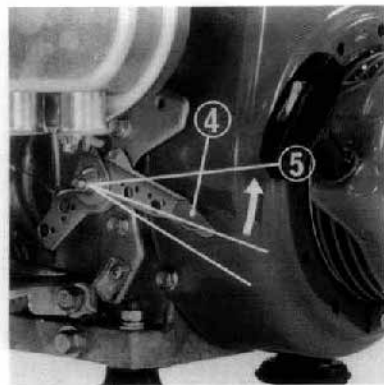

Stopping the Engine

Reduce engine speed to an idle before stopping the engine. Shutting off abruptly from high speed operation can cause flooding and difficult starting.

1. Adjust the throttle to "LOW".
2. Allow the engine to idle 1-2 minutes and switch "OFF".
3. Turn the fuel valve to "OFF".

NOTE:

To stop the engine in an emergency, turn the engine switch "OFF".

- (1) Throttle lever
(2) "LOW" position

- (3) Engine switch

- (4) Fuel valve

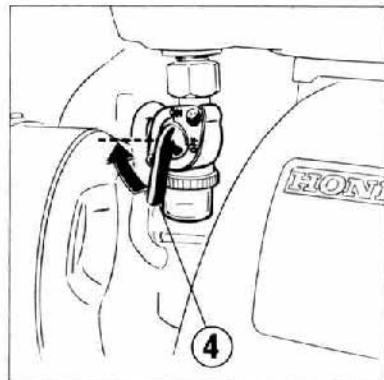
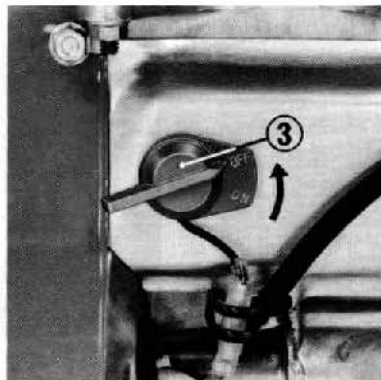
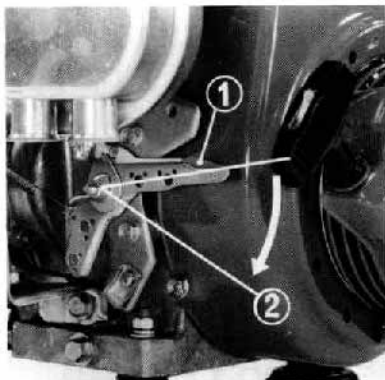

GENERATOR USE

A.C. Applications

WARNING

To prevent electrical shock from faulty appliances the generator should be grounded. Connect a length of heavy wire between the ground source and the terminal at the rear of the control box.

CAUTION

Do not connect the generator to a household electrical circuit. This could cause an overload and seriously damage the generator.

(1) Pilot lamp



14-EG1000

1. Start the engine and make sure that the pilot lamp lights. If it does not, the filament may be burnt out.
2. Verify that the generator is operating at 60Hz. If not, turn the throttle adjusting screw to obtain the proper frequency.
3. Plug in the appliance.

NOTE:

Watch the frequency meter carefully when connecting a tape recorder or radio. If the frequency drops, readjust the throttle as required.

(2) Frequency meter



The generator is equipped with an AVR (Auto Voltage Regulator). Voltage need not be adjusted if the frequency is adjusted properly. If the generator does not produce the specified voltage at the proper frequency, consult an authorized HONDA dealer.

- (3) Throttle lever
- (4) Throttle adjusting screw

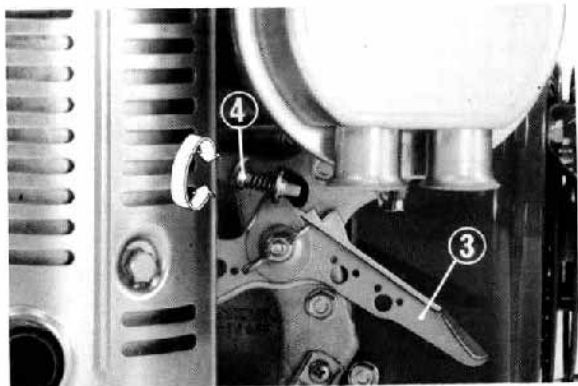

D.C. Application

CAUTION

Use the D.C. terminals for charging 12 volt automotive type batteries only. Check the positive (+) and negative (-) sides and make a proper connection. Do not reverse the polarity of the terminals when charging a battery. Serious damage to the generator and/or battery may occur.

NOTE:

The D.C. terminals must not be used while the A.C. outlet is in use.

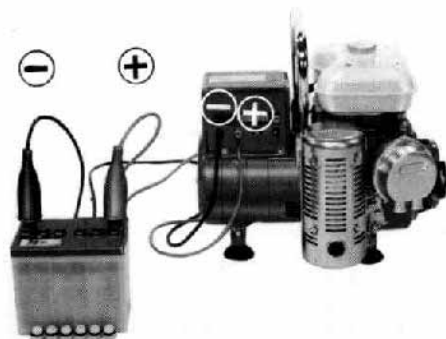

MAINTENANCE

The purpose of the maintenance schedule and adjustment is to keep the generator in the best operating condition.

Perform inspections as scheduled in the table on page 17.

WARNING

Shut off the engine before performing any maintenance. If the engine must be run, make sure the area is well ventilated. The exhaust contains poisonous carbon monoxide gas.

CAUTION

Use only genuine HONDA parts or their equivalent. The use of replacement parts which are not of equivalent quality may damage the generator.

Maintenance Schedule

REGULAR SERVICE PERIOD Perform at every indicated month or operating hour intervals, which- ever occurs first.		Daily	First 1 month or 20 Hrs. operating	Every 3 months or 50 Hrs. operating	Every 6 months or 100 Hrs. operating	Every one year or 300 Hrs. operating
ITEM						
Engine oil	Inspection	○				
	Change		○		○	
Air cleaner element	Inspection	○				
	Cleaning			○ (1)		
Fuel filter cleaning					○	
Spark plug maintenance					○	
Ignition timing adjustment						○ (2)
Valve clearance adjustment						○ (2)
Combustion chamber and valve cleaning						○ (2)
Fuel tube inspection (Replace if necessary)						○

NOTE (1): When used in dusty areas, service the air cleaner more frequently.

(2): These items should be serviced by an authorized Honda dealer, unless the owner has the proper tools and is mechanically proficient. See the Honda Shop Manual.

Tool Kit

The tools supplied are necessary for performing periodic maintenance, simple adjustments and repairs. Always keep the kit with the generator.

- (1) Tool bag
- (2) Plug wrench
- (3) Plug wrench handle
- (4) End wrench, 10x12 mm

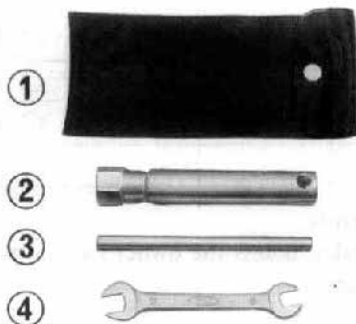

Changing Oil

Drain the oil while the engine is still warm to assure rapid and complete draining.

1. Remove the drain plug, drain the oil, and re-tighten the plug securely.
2. Refill with the recommended oil (see p. 8) and check the level.

- (1) Oil filler hole
- (2) Oil filler cap
- (3) Drain plug

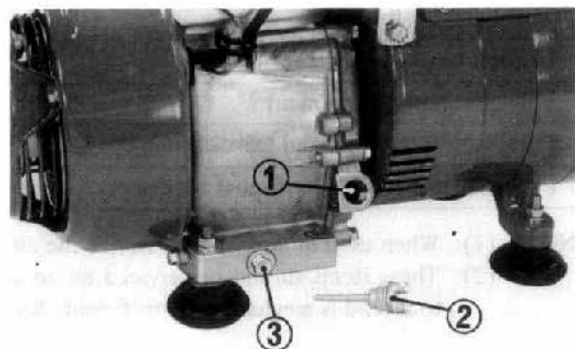

Air Cleaner Service

A dirty air cleaner will restrict air flow to the carburetor. To prevent carburetor malfunction, service the air cleaner regularly.

WARNING

Do not use gasoline or low flash point solvents for cleaning. They are flammable and explosive under certain conditions.

- (1) Air cleaner cover
(2) Wing nut

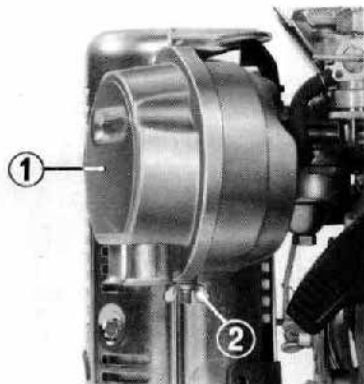

- (3) Element

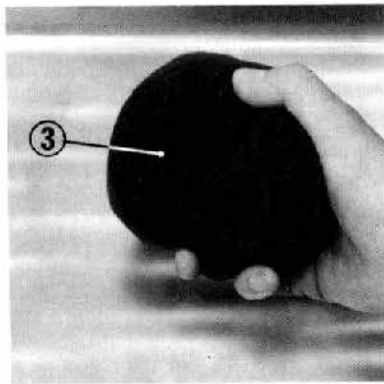
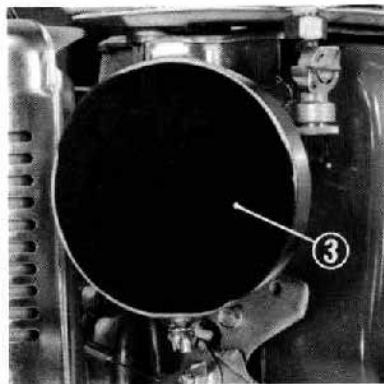

1. Loosen the wing nut, remove the air cleaner cover and remove the element.
2. Wash the element in a non-flammable or high flashpoint solvent and dry it thoroughly.
3. Soak the element in clean engine oil and squeeze out the excess oil.

Fuel Filter Service

The filter prevents dirt or water which may be in the fuel tank from entering the carburetor. If the engine has not been run for a long time, the filter should be cleaned.

1. Turn the fuel valve "OFF". Remove the ring nut and filter cup.
2. Clean the cup thoroughly. Remove any sediment with a cloth.
3. Re-assemble. Do not damage the rubber gasket.

(1) Fuel valve (2) Ring nut (3) Filter cup

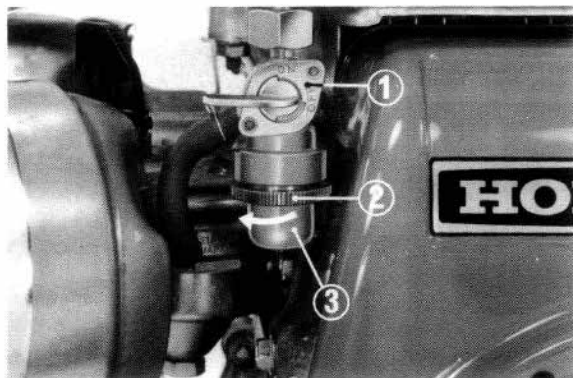

WARNING

After installing the filter cup, be sure to tighten the ring nut securely. Check for fuel leaks and remove any spilled fuel prior to starting.

(4) Rubber gasket

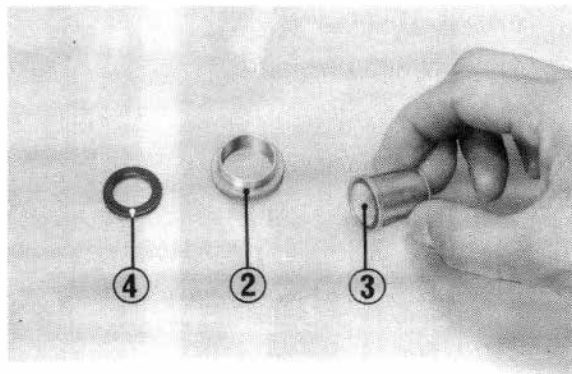

Spark Plug Service

To ensure proper engine operation the spark plug must be properly gapped and free of deposits.

1. Remove the spark plug with the plug wrench.
2. Use a wire brush to remove carbon deposits. Do not damage the electrodes.
3. Check the plug gap with a feeler gauge. Correct as necessary. Do not bend the center electrode.

- (1) Spark plug wrench
- (2) Plug wrench handle

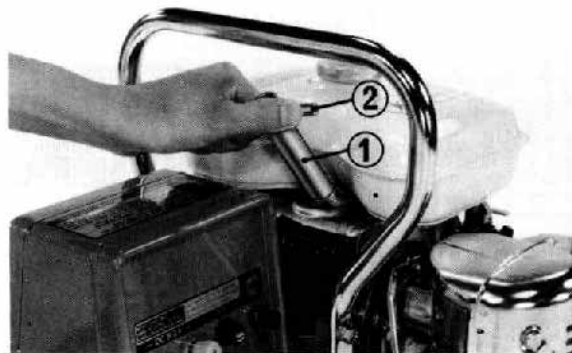

CAUTION

The spark plug must be securely tightened. An improperly tightened plug can damage the generator.



Ignition Timing Adjustment

Check the timing when specified by the periodic maintenance chart. Improper timing can cause starting difficulty and loss of power.

1. Remove the fan shroud, starter pulley, fan, flywheel, and point cover.
2. Using the woodruff key remount the flywheel on the crankshaft and check that the points start to open when the "F" mark on the flywheel passes the aligning mark on the crankcase.

If timing is not correct ----

3. Loosen the 5 mm screw and move the breaker plate to the right or left as required. Retighten the screw and recheck the timing.

(1) Point cover

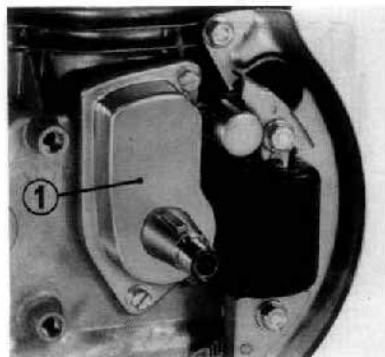

(2) Flywheel

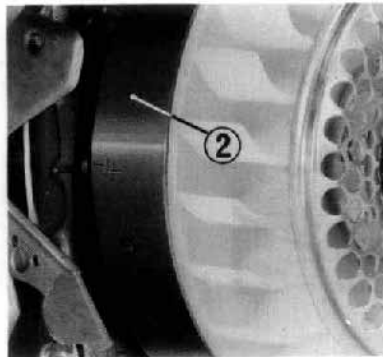

(3) Contact breaker points
(4) 5 mm screw

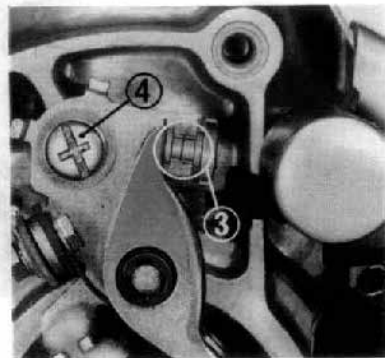

TRANSPORTING/STORAGE

WARNING

When transporting the generator, shut off the fuel valve and keep the generator level to prevent fuel spillage. Fuel vapor or spilled fuel may ignite.

Before storing the unit for an extended period:

1. Assure that the storage area is free of excessive humidity and dust.
2. Drain the fuel tank –
 - a. With the fuel valve “OFF”, remove the fuel filter cup.

- (1) Fuel valve
(2) Fuel filter cup

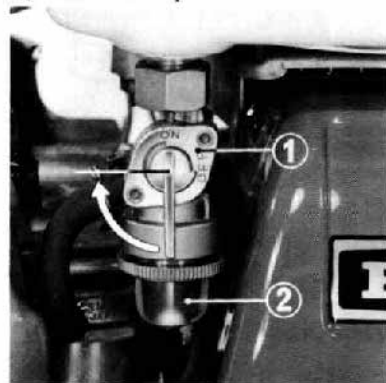

- (3) Carburetor
(4) Sealing bolt



- (5) Marks

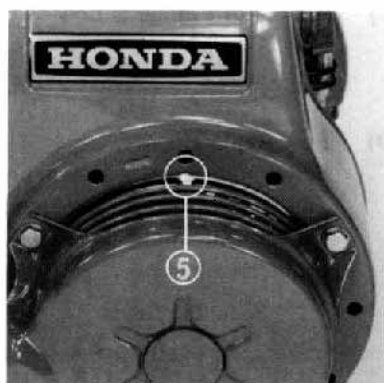

- b. Turn the valve “ON” and allow the tank to drain completely into a suitable container.
3. Drain the carburetor –

Loosen the carburetor drain bolt. The gas will drain through the bolt hole.
 4. Pull the starter rope so that the mark on the pulley is aligned with the index mark on the fan shroud. With the mark in this position on the compression stroke, the valves and points are closed. This helps protect the engine from corrosion.

TROUBLESHOOTING

A) Difficult Starting

- (1) Remove any appliances that may be connected to the generator.
- (2) Check the fuel level.
- (3) Check choke position.

B) No Electricity at the Outlet Receptacles

- (1) Be sure the A.C. fuse is good.
- (2) Check the electrical appliance or equipment for any defects.

C) Generator Voltage is Low

- (1) Check for correct frequency and adjust engine speed as required.

D) Fuse Replacement

Before replacing a blown fuse, determine the cause and correct the problem. Remove the old fuse by turning the holder counterclockwise.

Specified fuse:

AC— 8A

DC—15A

(1) Fuse holder

(2) Fuse (AC)

(3) Fuse (DC)

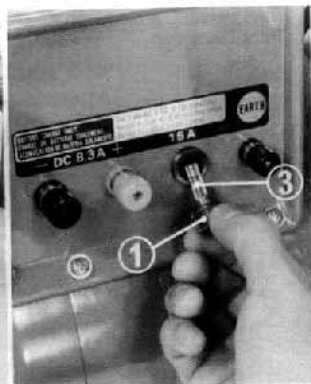
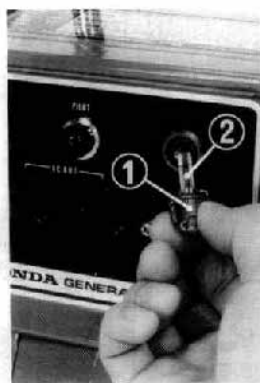

SPECIFICATIONS

Dimension and Weight

Length x Width x Height Dry weight	475 x 375 x 450 mm (18.7 x 14.8 x 17.7 in.) 29.0 kg (63.9 lbs.)
---------------------------------------	--

Engine

Model	Honda G150
Engine Type	4 cycle side valve, 1 cylinder, forced air cooled
Displacement [Bore x Stroke]	144 cc (8.8 cu. in.) [64 x 45 mm (2.5 x 1.8 in.)]
Ignition timing	BTDC 20° (fixed)
Ignition	Flywheel magneto
Oil capacity	0.7ℓ (1.5 US. pt.)
Fuel tank capacity	2.5ℓ (0.66 U.S. gal.)
Spark plug [Specified gap]	BR-4HS (NGK), W14FR-U (ND) [0.6–0.7mm (0.024–0.028 in.)]

Generator

AC output	Rated voltage Rated output Max output Cycles	115V 0.8 KVA (800W) [7.0A] 1.0 KVA (1,000W) 60 Hz
DC output	Only for charging 12V automotive batteries. Maximum charging output: 8.3A	

	Part Name
AVR	Automatic Voltage Regulator
CB	Control Box
Co	Condenser
CP ₆	6P Connector
CP ₄	4P Connector
EW	Exciter Winding
FM	Frequency Meter
Ⓢ M	Frequency Mark
Fu	Fuse
FW	Field Winding
Ge	Generator Block
GT	Ground Terminal
MW	Main Winding
OR	Output Receptacle
OT	Output Terminal
PL	Pilot Lamp
Ⓢ M	Voltage Mark
⊕ M	⊕Mark
⊕ R	⊕Red Terminal
⊖ M	⊖Mark
⊖ B	⊖Black Terminal

	Color
B	Black
Bl	Blue
Br	Brown
G	Green
Lg	Light Green
R	Red
W	White

Warranty Service

Owner Satisfaction

Your satisfaction and goodwill are important to your dealer and to us. Normally, any problems with the product will be handled by your dealer's service department. Sometimes, however, despite the best intentions of all concerned, misunderstandings can occur. If your problem has not been handled to your satisfaction, we suggest you take the following action:

- Discuss your problem with a member of dealership management. Often complaints can be quickly resolved at that level. If the problem has already been reviewed with the Service Manager, contact the owner of the dealership or the General Manager.
- If your problem still has not been resolved to your satisfaction, contact the Motorcycle and Power Products Customer Relations Department at the regional office of American Honda Motor Co., Inc. in your area. Regional office locations are shown on the following page. We will need the following information in order to assist you:
 - Your name, address, and telephone number
 - Product model and serial number
 - Date of purchase
 - Dealer name and address
 - Nature of the problem

After reviewing all the facts involved, you will be advised of what action can be taken. Please bear in mind that your problem will likely be resolved at the dealership, using the dealer's facilities, equipment, and personnel, so it is very important that your initial contact be with the dealer.

Your purchase of a Honda product is greatly appreciated by both the dealer and American Honda Motor Co., Inc. We want to assist you in every way possible to assure your complete satisfaction with your purchase.

Regional Office Locations

NORTHWEST REGIONAL OFFICE (includes Alaska)

American Honda Motor Co., Inc.
Motorcycle and Power Products
Customer Relations Department
P.O. Box 30285
Portland, Oregon 97220
Telephone: (503) 255-1186

MIDWEST REGIONAL OFFICE

American Honda Motor Co., Inc.
Motorcycle and Power Products
Customer Relations Department
P.O. Box 22
Greendale, Wisconsin 53129
Telephone: (414) 421-9300

NORTHEAST REGIONAL OFFICE

American Honda Motor Co., Inc.
Motorcycle and Power Products
Customer Relations Department
P.O. Box 749
Moorestown, New Jersey 08057
Telephone: (609) 778-1100



WESTERN REGIONAL OFFICE (includes Hawaii)

American Honda Motor Co., Inc.
Motorcycle and Power Products
Customer Relations Department
P.O. Box 420
Gardena, California 90247
Telephone: (213) 504-2524

SOUTHWEST REGIONAL OFFICE

American Honda Motor Co., Inc.
Motorcycle and Power Products
Customer Relations Department
P.O. Box 5406
Irving, Texas 75062
Telephone: (214) 258-6883

SOUTHEAST REGIONAL OFFICE (includes Puerto Rico)

American Honda Motor Co., Inc.
Motorcycle and Power Products
Customer Relations Department
6684 Jimmy Carter Boulevard
Norcross, Georgia 30071
Telephone: (404) 448-1992

Current customer service contact information:

United States, Puerto Rico, and U.S. Virgin Islands:

Honda Power Equipment dealership personnel are trained professionals. They should be able to answer any question you may have. If you encounter a problem that your dealer does not solve to your satisfaction, please discuss it with the dealership's management. The Service Manager or General Manager can help. Almost all problems are solved in this way.

If you are dissatisfied with the decision made by the dealership's management, contact the Honda Power Equipment Customer Relations Office. You can write:

American Honda Motor Co., Inc.
Power Equipment Division
Customer Relations Office
4900 Marconi Drive
Alpharetta, GA 30005-8847

Or telephone: (770) 497-6400 M-F, 8:30 am - 5:00 pm EST

When you write or call, please provide the following information:

- Model and serial numbers
- Name of the dealer who sold the Honda power equipment to you
- Name and address of the dealer who services your equipment
- Date of purchase
- Your name, address, and telephone number
- A detailed description of the problem



HONDA
HONDA MOTOR CO., LTD. TOKYO, JAPAN

3187500
00X31-875-0000



© 821
PRINTED IN JAPAN