

HONDA

Power

Equipment

Owner's Manual

EB6500

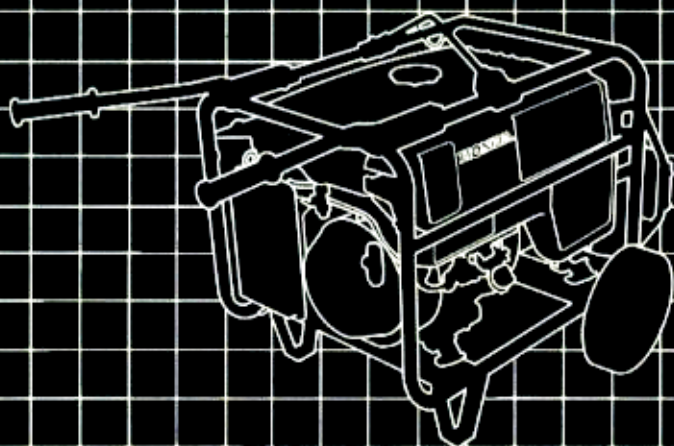

Thank you for purchasing a Honda generator.

This manual describes the operation and maintenance of the Honda Generator: EB6500

All information in this publication is based on the latest product information available at the time of printing.

Honda Motor Co., Ltd. reserves the right to make changes at any time without notice and without incurring any obligation.

No part of this publication may be reproduced without written permission. This manual should be considered a permanent part of the generator and should remain with it if it is resold.

READ THIS OWNER'S MANUAL CAREFULLY. Pay special attention to these symbols and any instructions that follow:

▲ DANGER Indicates serious injury or death **WILL** result if instructions are not followed.

▲ WARNING Indicates a strong possibility that serious injury or death may result if instructions are not followed.

CAUTION: Indicates a possibility that minor injury could result if instructions are not followed.

NOTICE Indicates that equipment or property damage could result if instructions are not followed.

Honda generator is designed to give safe and dependable service if operated according to instructions. Operating this generator requires special effort on your part to ensure your safety and the safety of others. Using this generator for a purpose not intended may cause injury or property damage.

▲ WARNING
Careless operation or misuse may cause injury or property damage. Read and understand the owner's manual before operating this generator.

If a problem should arise, or if you have any questions about your generator, see an authorized Honda generator dealer.

HONDA MOTOR CO., LTD. 1990, ALL RIGHTS RESERVED

CONTENTS

1. SAFETY INFORMATION.....	3
2. COMPONENT IDENTIFICATION	6
3. PRE-OPERATION CHECK	8
4. STARTING THE ENGINE.....	12
5. GENERATOR USE	17
6. STOPPING THE ENGINE	25
● High altitude operation	26
7. MAINTENANCE	27
8. TRANSPORTING/STORAGE	36
9. TROUBLESHOOTING.....	38
10. WIRING DIAGRAM	40
11. SPECIFICATIONS	41
12. HANGER KIT INSTALLATION	42
13. 2 WHEEL KIT INSTALLATION	43
14. BATTERY TRAY KIT	44
15. WARRANTY SERVICE.....	46

1. SAFETY INFORMATION

SAFETY INFORMATION

For your safety and the safety of others, pay special attention to these precautions:

Operator Responsibility

- Know how to stop the generator quickly in case of emergency. Understand the use all generator controls, output receptacles, and connections.
- Be sure that anyone who operates the generator receives proper instruction. Do not let children operate the generator without parental supervision.

Electric Shock Hazards

- The generator produces enough electric power to cause a serious shock or electrocution if misused.
- Using a generator or electrical appliance in wet conditions, such as rain or snow, or near a pool or sprinkler system, or when your hands are wet, could result in electrocution. Keep the generator dry.
- If the generator is stored outdoors, unprotected from the weather, check the Ground Fault Circuit Interrupter (GFCI) receptacle, and all other electrical components on the control panel, before each use. Moisture or ice can cause a malfunction or short circuit in electrical components which could result in electrocution.
- Do not connect to a building's electrical system unless an isolation switch has been installed by a qualified electrician.

Fire and Burn Hazards

- The exhaust system gets hot enough to ignite some materials.
 - Keep the generator at least 1 meter (3 feet) away from buildings and other equipment during operation.
 - Keep flammable materials away from the generator.
- The muffler becomes very hot during operation and remains hot for a while after stopping the engine. Be careful not to touch the muffler while it is hot. Let the engine cool before storing the generator indoors.
- Gasoline is extremely flammable and is explosive under certain conditions. Do not smoke or allow flames or sparks where the generator is refueled or where gasoline is stored. Refuel in a well-ventilated area with the engine stopped.

Carbon Monoxide Hazards

- Exhaust contains poisonous carbon monoxide, a colorless and odorless gas. Breathing exhaust can cause loss of consciousness and may lead to death.
- If you run the generator in an area that is confined, or even partially enclosed, the air you breathe could contain a dangerous amount of exhaust gas. To keep exhaust gas from building up, provide adequate ventilation.

WARNING LABEL LOCATION

Read these labels before operating the generator.

Your Honda generator comes with several labels containing important safety information. Anyone who uses the generator should read and understand this information before operating the generator.

The labels should be considered as permanent parts of the generator. If a label comes off or becomes hard to read, contact an authorized Honda generator dealer for replacements.

WARNING DO NOT USE INDOORS. EXHAUST GAS CONTAINS POISONOUS CARBON MONOXIDE.
ATTENTION NE PAS UTILISER DANS UN ENDROIT FERME A CAUSE DU RISQUE D'EMPOISONNEMENT DU GAZ.
ATENCION NO LO USE EN LUGARES CERRADOS PORQUE EL MONOXIDE DE CARBONO ES VENENOSO.



■ CHECK FOR SPILLED FUEL OR FUEL LEAKS
STOP ENGINE BEFORE REFUELING
■ CONTRÔLER QU'IL N'Y A RI FUIE NI ESSEML
REPARQUE SUR L'APPAREIL
ARRÊTER LE MOTEUR AVANT DE RÉFUIRE LE PLEIN
■ INSPECCIONAR PARA COMBUSTIBLE DERRAMADO
O ESCAPE
PARAR MOTOR ANTES DE ECHAR

⚠ WARNING
USING THE GENERATOR IN RAIN, SNOW OR NEAR WATER CAN LEAD TO DEATH FROM ELECTRIC SHOCK. KEEP GENERATOR DRY.

⚠ WARNING
ELECTROCUTION OR PROPERTY DAMAGE CAN OCCUR. DO NOT CONNECT THIS GENERATOR TO ANY BUILDING'S ELECTRICAL SYSTEM UNLESS AN ISOLATION SWITCH HAS BEEN INSTALLED BY A LICENSED ELECTRICIAN. READ OWNER'S MANUAL CAREFULLY.

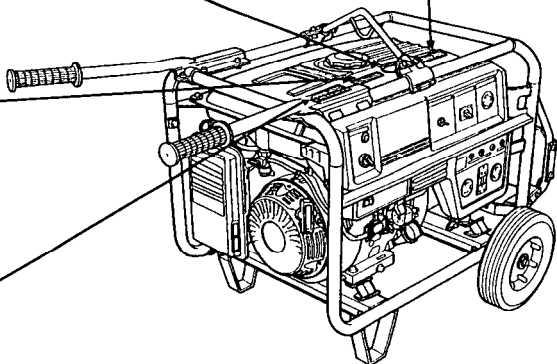

EB6500 HONDA MOTOR CO., LTD. MADE IN JAPAN (®)	
CAUTION ■ BE SURE TO FILL CRANKCASE WITH RECOMMENDED OIL BEFORE USING. FOR DETAILED EXPLANATION, SEE THE OWNER'S MANUAL.	AC VOLTAGE 120/240V FREQUENCY 60Hz RATED OUTPUT 5.5kVA MAX. OUTPUT 6.5kVA PHASE 1φ FUEL GASOLINE (PETROL)

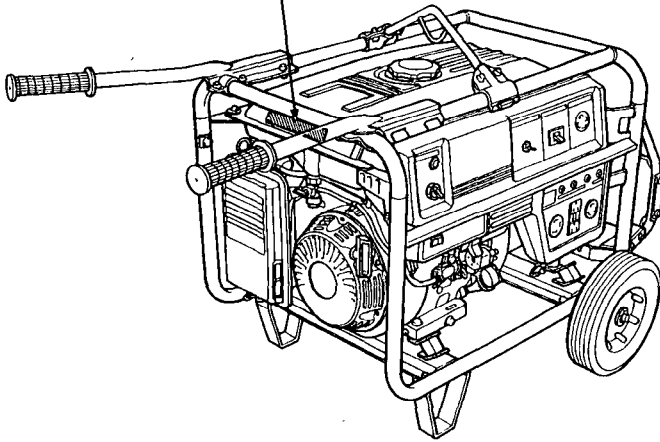

2.COMPONENT IDENTIFICATION

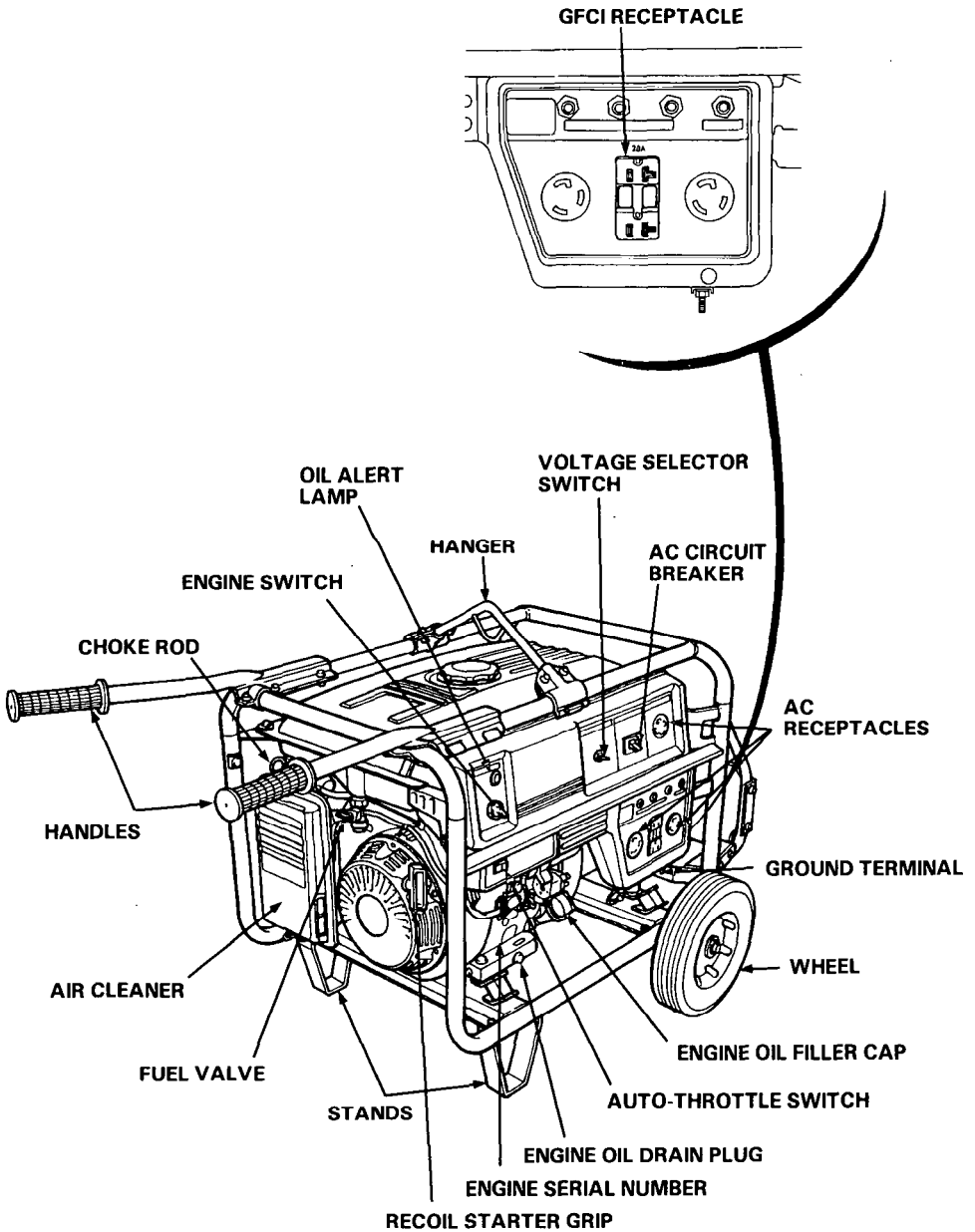

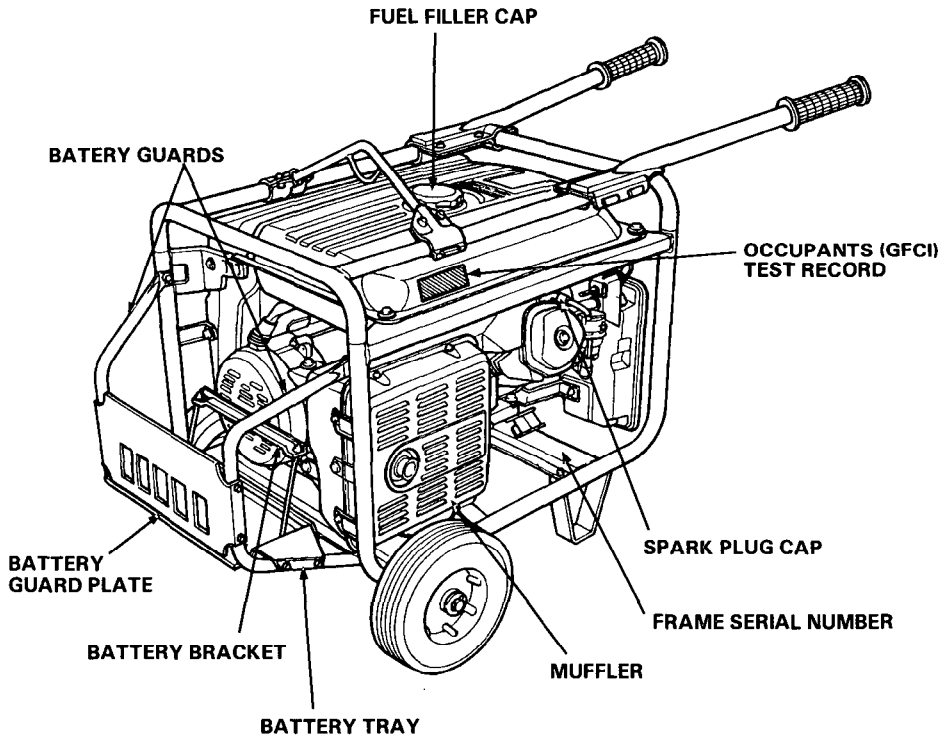

* Record the engine and frame serial numbers for your future reference. Refer to these serial numbers when ordering parts, and when making technical or warranty inquiries (see page 46)

Frame serial number: _____

Engine serial number: _____

3. PRE-OPERATION CHECK

Engine oil

NOTICE

- Engine oil is a major factor affecting engine performance and service life. Non-detergent and 2-stroke engine oils are not recommended.
- Check the generator on a level surface with the engine stopped.

Use Honda 4-stroke oil, or an equivalent high detergent, premium quality motor oil certified to meet or exceed U.S. automobile manufacturer's requirements for Service Classification SG, SF/CC, CD. Motor oils classified SG, SF/CC, CD will show this designation on the container.

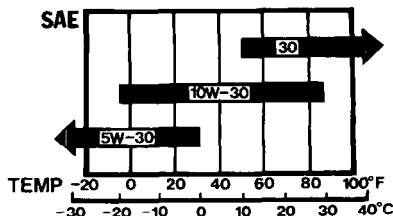

SAE 10W-30 is recommended for general, all-temperature use. Other viscosities shown, in the chart may be used when the average temperature in your area is within the indicated range.

1. Remove the oil filler cap and wipe the dipstick clean.
2. Check the oil level by inserting the dipstick in the filler neck without screwing it in.
3. If the level is low, add the recommended oil to the upper mark on the dipstick.

NOTE:

The Oil Alert system will automatically stop the engine before the oil level falls below the safe limit. However, to avoid the inconvenience of an unexpected shutdown, it is still advisable to visually inspect the oil level regularly.

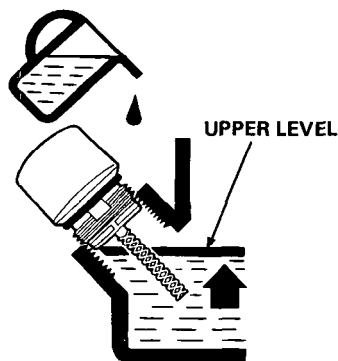
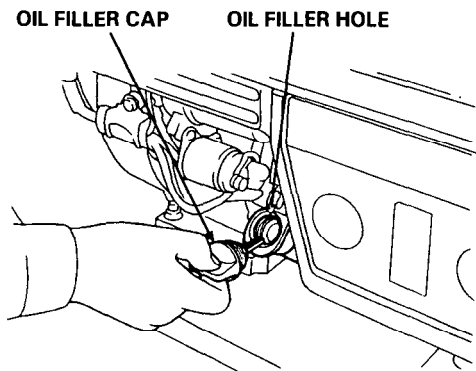

Fuel

Remove the filler cap and check the fuel level. Refill the tank if the fuel level is low. Do not fill above the shoulder of fuel strainer.

Your engine is designed to use any gasoline that has a pump octane number $(R + M)/2$ of 86 or higher, or that has a research octane number of 91 or higher. Gasoline pumps at service station normally display the pump octane number.

We recommend that you use unleaded fuel because it produces fewer engine and spark plug deposits and extends the life of exhaust system components.

Never use stale or contaminated gasoline or an oil/gasoline mixture. Avoid getting dirt, dust or water in the fuel tank. Use of a lower octane gasoline can cause persistent "pinging" or heavy "spark knock" (a metallic rapping noise) which, if severe, can lead to engine damage.

NOTICE

If "spark knock" or "pinging" occurs at a steady engine speed under normal load, change brands of gasoline. If spark knock or pinging persists, consult your authorized Honda dealer. Failure to do so is considered misuse, and damage caused by misuse is not covered by Honda's Limited Warranty.

Occasionally you may hear light spark knock while operating under heavy loads. This is no cause for concern. It simply means your engine is operating efficiently.

Fuel tank capacity: 17.0 ℓ (4.49 US gal , 3.74 Imp gal)

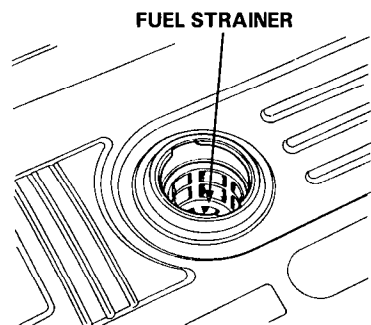
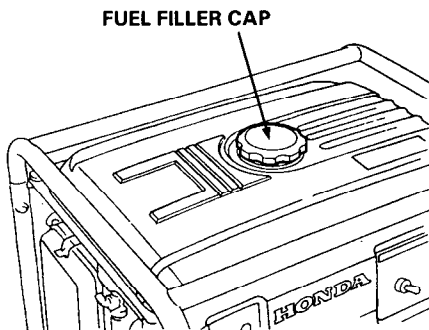

▲ WARNING

- Gasoline is extremely flammable and is explosive under certain conditions.

Refuel in a well-ventilated area with the engine stopped. Do not smoke or allow flames or sparks in the area where the engine is refueled or

- where gasoline is stored.

Do not overfill the fuel tank (there should be no fuel in the filler neck).

After refueling, make sure the tank cap is closed properly and securely.

- Be careful not to spill fuel when refueling. Spilled fuel or fuel vapor may ignite. If any fuel is spilled, make sure the area is dry before starting the engine.
 - Avoid repeated or prolonged contact with skin or breathing of vapor.
- KEEP OUT OF REACH OF CHILDREN.**

GASOLINES CONTAINING ALCOHOL

If you decide to use a gasoline containing alcohol (gasohol), be sure its octane rating is at least as high as that recommended by Honda. There are two types of "gasohol": one containing ethanol, and the other containing methanol.

Do not use gasohol that contains more than 10% ethanol. Do not use gasoline containing methanol (methyl or wood alcohol) that does not also contain cosolvents and corrosion inhibitors for methanol. Never use gasoline containing more than 5% methanol, even if it has cosolvents and corrosion inhibitors.

NOTE:

- Fuel system damage or engine performance problems resulting from the use of fuels that contain alcohol is not covered under the warranty. Honda cannot endorse the use of fuels containing methanol since evidence of their suitability is as yet incomplete.
- Before buying fuel from an unfamiliar station, try to find out if the fuel contains alcohol, if it does, confirm the type and percentage of alcohol used.

If you notice any undesirable operating symptoms while using a gasoline that contains alcohol, or one that you think contains alcohol, switch to a gasoline that you know does not contain alcohol.

Air cleaner

Check the air cleaner elements to be sure they are clean and in good condition. Clean or replace the element if necessary (page 30).

NOTICE

Never run the engine without the air cleaner. Rapid engine wear will result.

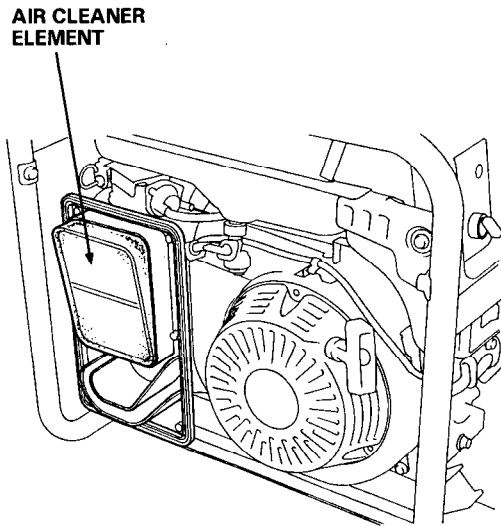

4. STARTING THE ENGINE

1. Make sure that the AC circuit breaker is in the OFF position. The generator may be hard to start if a load is connected.

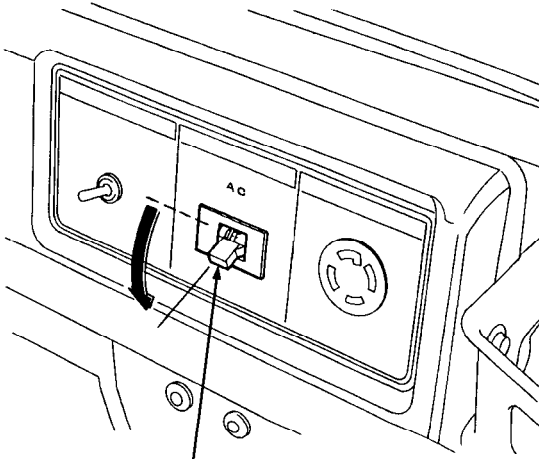

AC CIRCUIT BREAKER

2. Turn the fuel valve to the ON position.

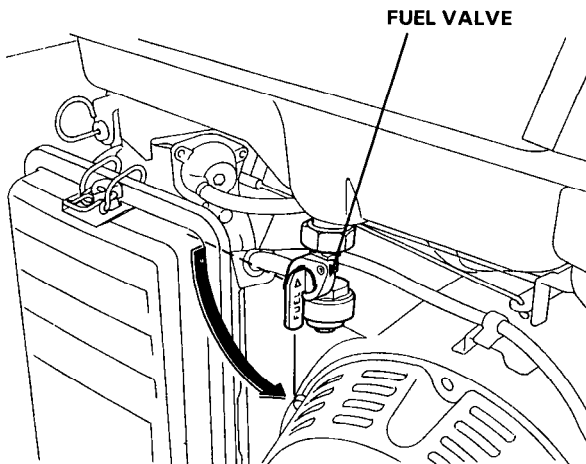

FUEL VALVE

3. Pull the choke rod out to the CLOSED position.

NOTE:

Do not use the choke if the engine is warm or if the air temperature is high.

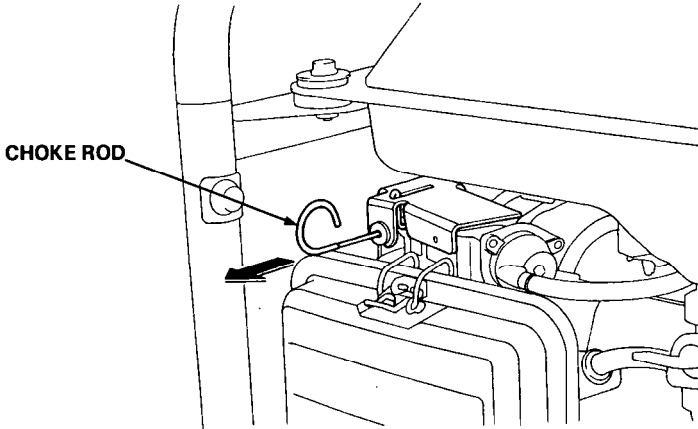

4. Make sure the auto-throttle switch is OFF, or more time will be required for warm up.

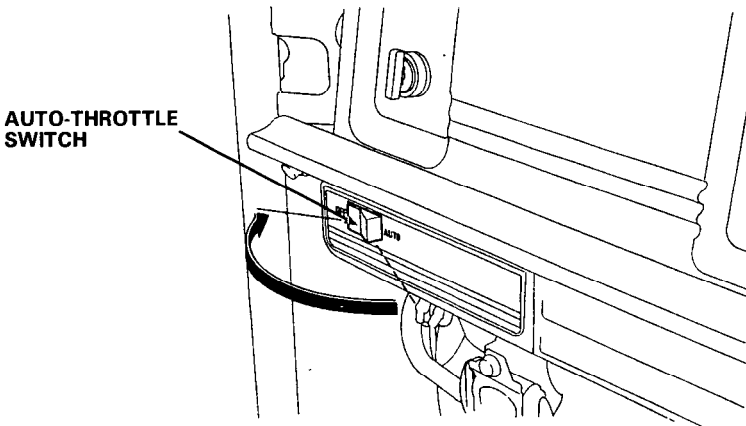

5. Start the engine

● With recoil starter:

Turn the engine switch to the ON position

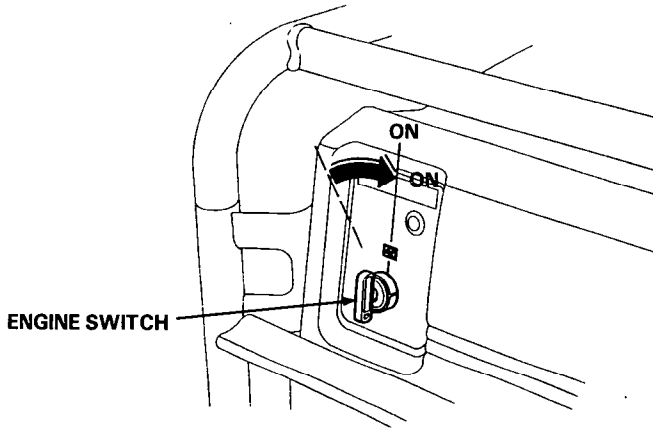

Pull the starter grip lightly until resistance is felt, then pull briskly.

NOTICE

Do not allow the starter grip to snap back against the engine. Return it gently to prevent damage to the starter or housing.

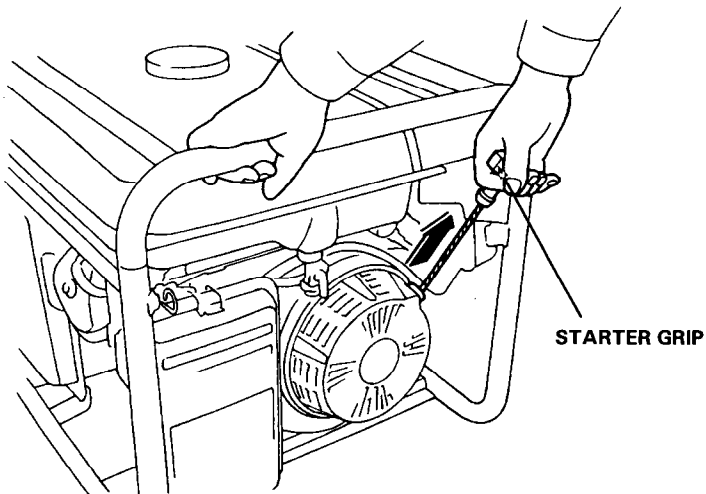

● With electric starter

Turn the engine switch to the START position and hold it there for 5 seconds or until the engine starts.

NOTICE

- Operating the starter motor for more than 5 seconds can damage the motor. If the engine fails to start, release the switch and wait 10 seconds before operating the starter again.
- If the speed of the starter motor drops after a period of time, it is an indication that the battery should be recharged.

ENGINE SWITCH

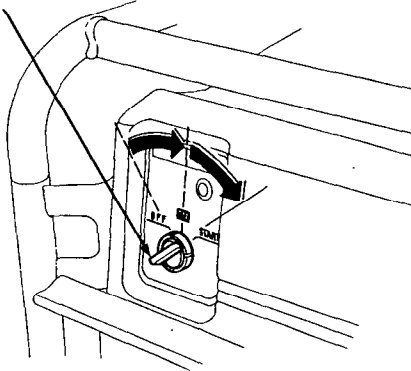

6. When the engine starts, allow the engine switch to return to the ON position

ENGINE SWITCH

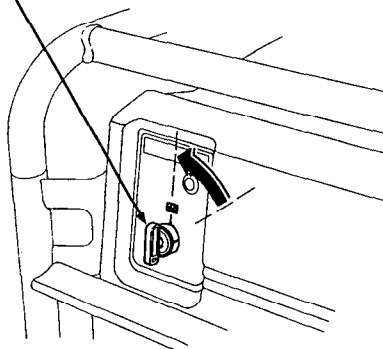

7. Push the choke rod to the OPEN position as the engine warms up.

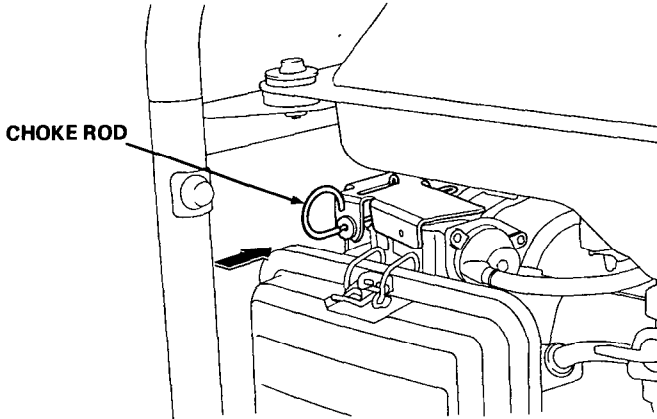

8. If you wish to use the auto-throttle system, turn the auto-throttle switch to the AUTO position after the engine has warmed up for 2 or 3 minutes.

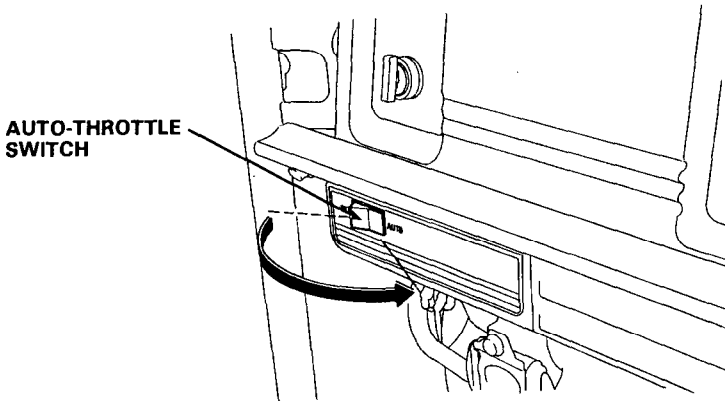

5. GENERATOR USE

▲ WARNING

- To prevent electrical shock from faulty appliances, make sure all appliances are in good working order before connecting them to the generator.
- Connections for standby power to a building's electrical system must be made by a qualified electrician and must comply with all applicable laws and electrical codes. Improper connections can allow electrical current from the generator to backfeed into the utility lines. Such backfeed may electrocute utility company workers or others who contact the lines during a power outage, and when utility power is restored, the generator may explode, burn, or cause fires in the building's electrical system.

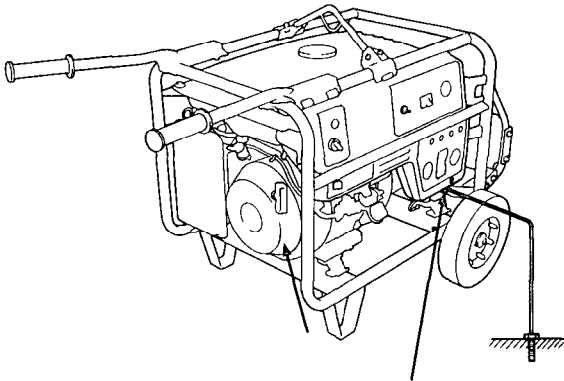

GROUND TERMINAL

NOTICE

- Limit operation requiring never exceed the maximum power.
Maximum power is:
6.5 kVA
For continuous operation, do not exceed the rated power of:
5.5 kVA for more than 30 minutes.
In either case, the total wattage of all appliances connected must be considered.
- Most motorized appliance require more than their rated wattage for startup.
- Do not exceed the current limit specified for any out put.

NOTE:

You can determine an appliance's VA (volt amp) rating by multiplying its required voltage by the amount of current (amps) it draws.

Auto-throttle system

With the switch in the AUTO position, engine speed is automatically reduced to an idle when all loads are turned off or disconnected. When appliances are turned on or reconnected, the engine resumes the rated speed. At OFF, the auto-throttle system does not operate.

NOTE:

- AUTO is recommended to minimize fuel consumption when no load is applied.
- The auto-throttle system will not respond to electrical loads of less than 1 ampere.
- The system is not-effective for use with appliances that require only momentary power. To avoid extended warm-up periods, keep the switch OFF until the engine reaches operating temperature.

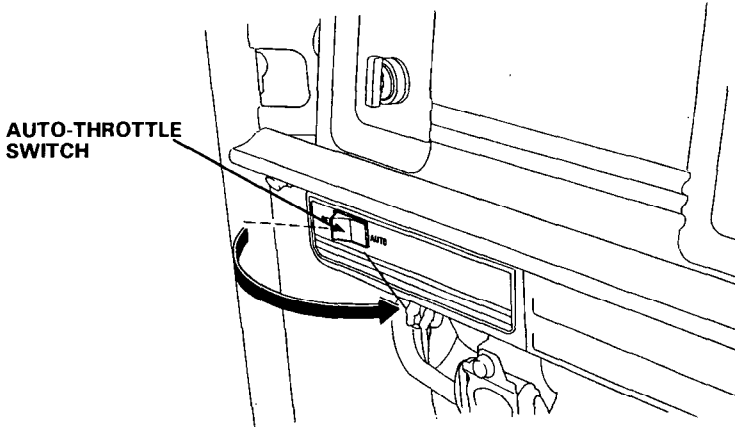

Oil alert system

The Oil Alert system is designed to prevent engine damage caused by an insufficient amount of oil in the crankcase. Before the oil level in the crankcase can fall below a safe limit, the Oil Alert system will automatically stop the engine (the engine switch will remain in the ON position).

If the Oil Alert system stops the engine, the Oil Alert lamp will flash when you operate the starter, and the engine will not run. If this occurs, add engine oil (p. 8).

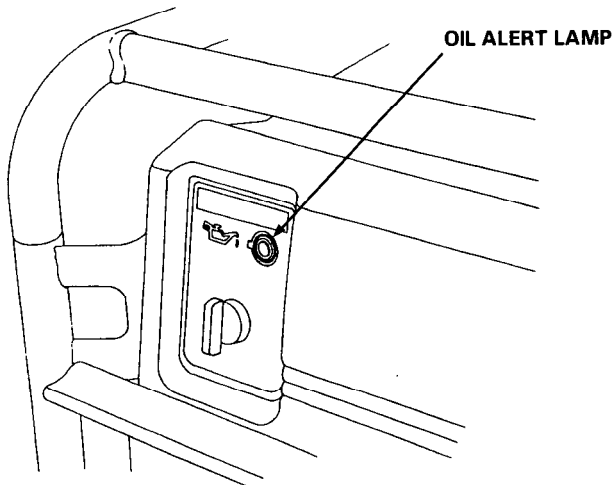

Circuit Breaker

The circuit breaker protects the individual circuit protectors and the 50A 120/240V receptacle. The circuit breaker will automatically switch OFF if the circuit is overloaded or the appliance plugged into the circuit is faulty. If the circuit breaker is switched OFF automatically, check that the appliance is working properly and that it does not exceed the rated load capacity of the circuit before switching the circuit breaker ON again.

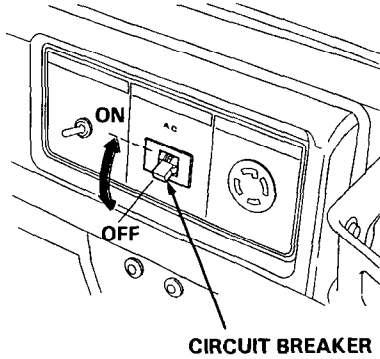

Circuit Protector

The circuit protectors will automatically switch OFF if the individual circuit is overloaded or the appliance plugged into the circuit is faulty. If the circuit protector is switched OFF automatically, check that the appliance is working properly and that it does not exceed the rated load capacity of the circuit before resetting the circuit protector.

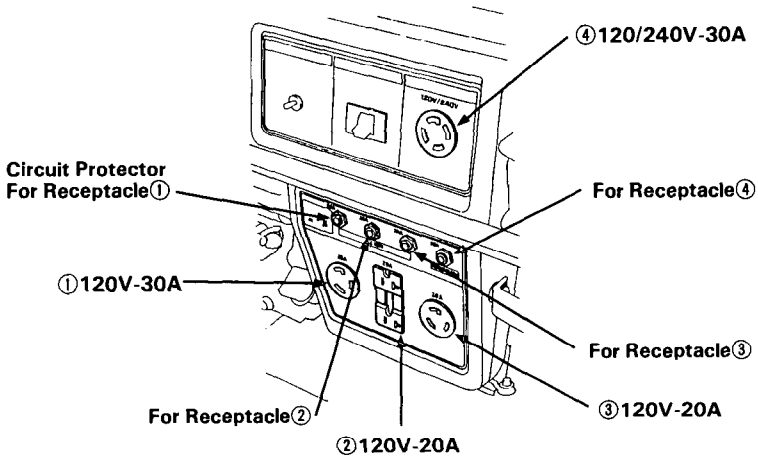

Ground Fault Circuit Interrupter (GFCI) Receptacle

▲ WARNING

Using the generator in rain, snow or near water can lead to death from electric shock. Keep the generator dry.

This receptacle is protected by a Ground Fault Circuit interrupter (GFCI) for protection against electrical shock.

TEST BUTTON To test, depress the "TEST" button
(see page 22)

RESET BUTTON To restore power, depress the "RESET" button
(see page 23)

Perform this test monthly to ensure proper operation of the GFCI Receptacle. If the generator is stored outdoors, unprotected from the weather, test the GFCI receptacle before each use. Record your test on the GFCI test card provided on the fuel tank.

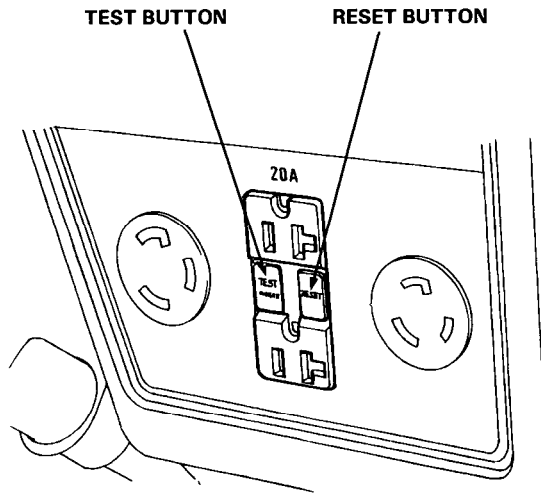

INSPECTION

Before each use:

If the generator is stored outdoors, unprotected from the weather, test the GFCI receptacle before each use as described in the monthly inspection.

Monthly: Under normal operating conditions, perform the GFCI test monthly. Record your test on the GFCI test card provided on the fuel tank.

1. Unplug all appliance's from the GFCI receptacles.
2. Start the engine.
3. Turn the circuit breaker ON.
4. Make sure the auto-throttle switch is OFF

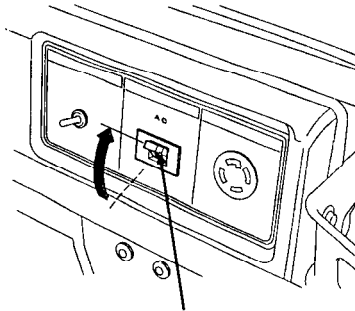

CIRCUIT BREAKER

5. Press the TEST BUTTON

- The RESET BUTTON should extend with a click.
- If the RESET BUTTON does not extend, contact an authorized Honda generator dealer.

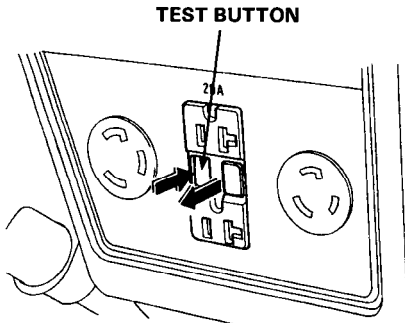

TEST BUTTON

6. Press the RESET BUTTON

- The RESET BUTTON should be flush with the test button.
- If the RESET BUTTON is not flush with the TEST BUTTON, contact an authorized Honda generator dealer.

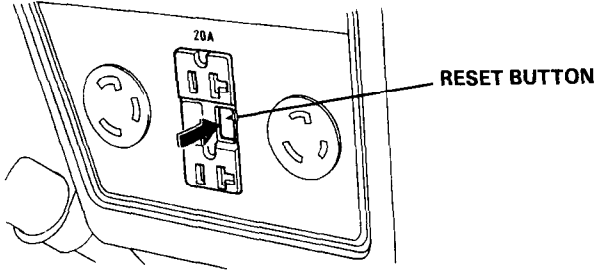

7. When the RESET BUTTON extends during operation:

- Unplug all appliance's from the GFCI protected receptacle.
- Press the RESET BUTTON:

IF THE GFCI CAN NOT BE RESET: The GFCI is faulty. Contact an authorized Honda generator dealer.

IF THE GFCI RESETS PROPERLY: Check the appliance or its cord.

AC operation

1. Start the engine.
2. Turn the voltage selector switch to either position as required.

NOTE:

With the voltage selector switch in the "120V/240V" position, you can use the 120V and 240V receptacles simultaneously. If you are not using the 240V receptacle, but you require more power from the 120V twistlock receptacle, then turn the switch to the "120V" position.

3. Switch on the AC Circuit Breaker.
4. Plug in the appliance.

NOTICE

- Be sure that appliances do not exceed the generator's rated load capacity for more than 30 minutes, and that they never exceed the maximum load capacity. Substantial overloading will switch off the circuit breaker. Marginal overloading may not switch off the circuit breaker, but it will shorten the service life of the generator.
- If an overloaded circuit causes the AC circuit breaker to switch off, reduce the electrical load on the circuit, and wait a few minutes before resetting the circuit breaker.
- Be sure that all appliances are in good working order before connecting them to the generator. If an appliance begins to operate abnormally, becomes sluggish, or stops suddenly, turn off the circuit breaker and the generator engine switch immediately. Then disconnect the appliance and examine it for signs of malfunction.

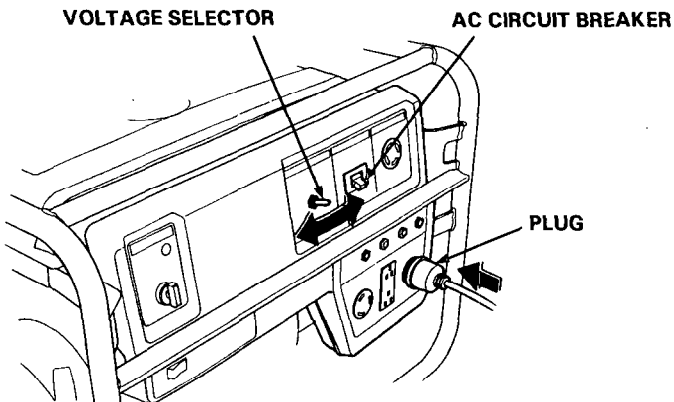

6. STOPPING THE ENGINE

NOTE:

To stop the engine in an emergency, turn the engine switch to the OFF position.

In normal use:

1. Turn the AC circuit breaker to the OFF position.

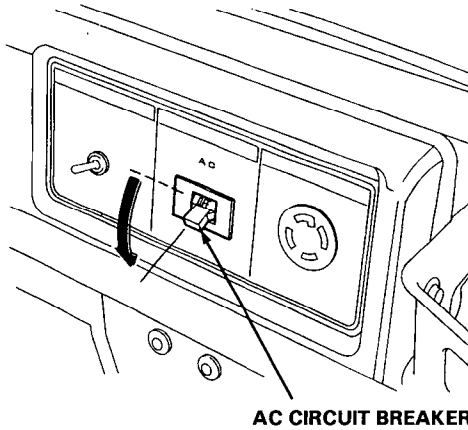

2. Move the engine switch to the OFF position.

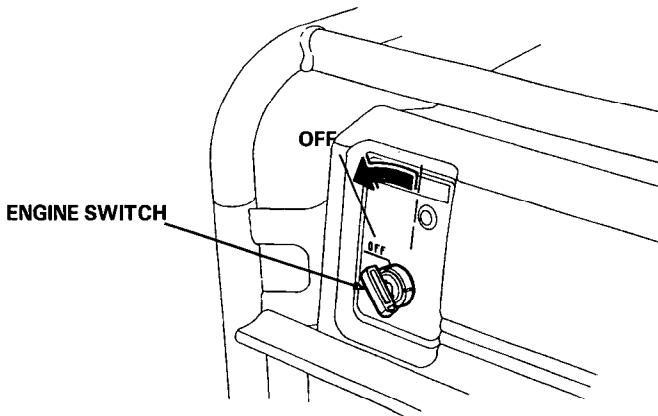

3. Turn the fuel valve to the OFF position.

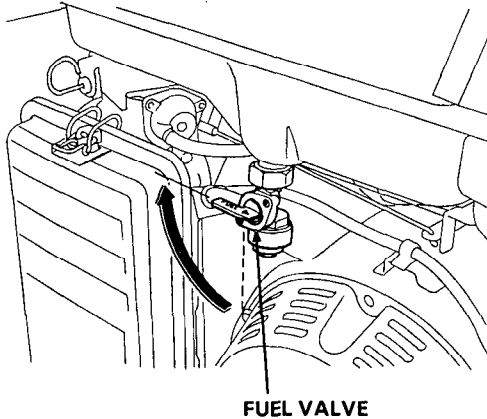

● High altitude operation

At high altitude, the standard carburetor air-fuel mixture will be excessively rich. Performance will decrease, and fuel consumption will increase.

High altitude performance can be improved by installing a smaller diameter main fuel jet in the carburetor and readjusting the pilot screw. If you always operate the engine at altitudes higher than 6,000 feet above sea level, have an authorized Honda generator dealer perform this carburetor modification.

Even with suitable carburetor jetting, engine horsepower will decrease approximately 3.5% for each 1,000 foot increase in altitude. The effect of altitude on horsepower will be greater than this if no carburetor modification is made.

NOTICE

Operation of the generator at an altitude lower than the carburetor is jetted for may result in reduced performance, overheating, and serious engine damage caused by an excessively lean air/fuel mixture.

7. MAINTENANCE

Periodic maintenance and adjustment is necessary to keep the generator in good operating condition. Perform the service and inspection scheduled in the table on the next page.

▲WARNING

Shut off the engine before performing any maintenance. If the engine must be run, make sure the area is well ventilated. Exhaust gas contains poisonous carbon monoxide.

NOTICE

Use only genuine HONDA parts or their equivalent for maintenance or repair. Replacement parts which are not of equivalent quality may damage the generator.

Tool kit

The tools supplied with the generator will help you to perform the owner maintenance procedures listed on the following page. Always keep this tool kit with the generator.



10 x 12 mm WRENCH



SCREW DRIVER



PLUG WRENCH



DRIVER HANDLE



HANDLE BAR

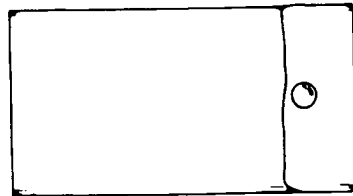

TOOL BAG

Maintenance schedule

REGULAR SERVICE PERIOD Performed at every indicated month or operating hour interval, whichever comes first.		Each use	First month or 20 Hrs.	Every 3 months or 50 Hrs.	Every 6 months or 100 Hrs.	Every year or 300 Hrs.	
ITEM							
Engine oil	Check level	○					
	Change		○		○		
Air cleaner	Check	○					
	Clean			○(1)			
Sediment cup	Clean				○		
Spark plug	Check-Clean				○		
Spark arrester	Clean				○		
Valva clearance	Check-Adjust					○(2)	
Fuel tank and strainer	Clean					○(2)	
Fuel line	Check (Replace if necessary)	Every 2 years(2)					

NOTE: (1): Service more frequently when used in dusty areas.

(2): This service should be performed by an authorized Honda generator dealer unless the owner has the proper tools and is mechanically proficient. See the Honda Shop Manual.

Engine oil change

Drain the oil while the engine is warm to assure rapid and complete draining.

1. Remove the drain plug and filler cap, and drain the oil.
2. Retighten the plug securely.
3. Refill with the recommended oil (see page 8) and check the level.

Oil capacity: 1.1 ℓ (1.2 US qt , 1.0 Imp qt)

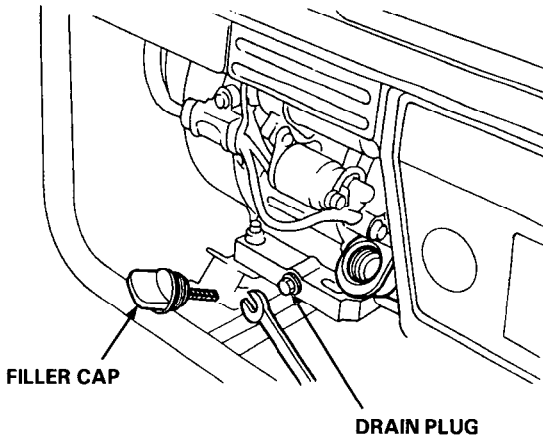

CAUTION:

Used motor oil may cause skin cancer if repeatedly left in contact with the skin for prolonged periods. Although this is unlikely, unless you handle used oil on a daily basis, it is still advisable to thoroughly wash your hands with soap and water as soon as possible after handling used oil.

NOTE:

Please dispose of used motor oil in a manner that is compatible with the environment. We suggest you take it in a sealed container to your local service station for reclamation. Do not throw it in the trash or pour it on the ground.

Air cleaner service

A dirty air cleaner will restrict air flow to the carburetor. To prevent carburetor malfunction, service the air cleaner regularly (page 28). Service more frequently when operating the generator in extremely dusty areas.

▲ WARNING

Using gasoline or flammable solvent to clean the filter element can cause a fire or explosion. Use only soapy water or nonflammable solvent.

NOTICE

Never run the generator without the air cleaner. Rapid engine wear will result.

1. Unsnap the air cleaner cover clips, remove the air cleaner cover, and remove the element.

AIR CLEANER COVER

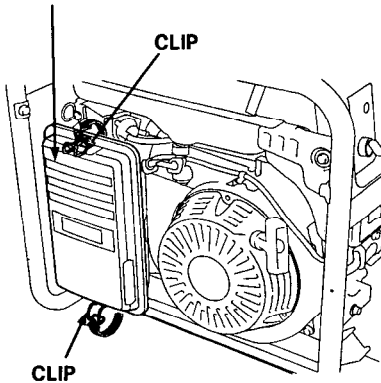

AIR CLEANER ELEMENT

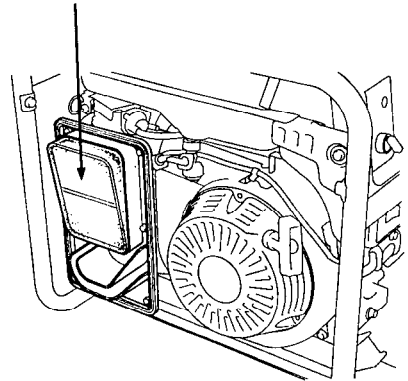

-
2. Wash the element in a solution of household detergent and warm water, then rinse thoroughly, or wash in nonflammable or high flash point solvent. Allow the element to dry thoroughly.
 3. Soak the element in clean engine oil and squeeze out the excess oil. The engine will smoke during initial start-up if too much oil is left in the element.
 4. Reinstall the air cleaner element and the cover.

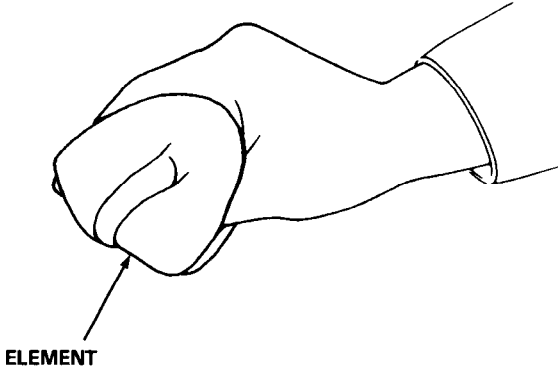

Sediment cup cleaning

The sediment cup prevents dirt or water which may be in the fuel tank from entering the carburetor. If the engine has not been run for a long time, the sediment cup should be cleaned.

1. Turn the fuel valve to the OFF position. Remove the sediment cup.
2. Clean the cup thoroughly.
3. Check to be sure the O-ring is in place, and reinstall the sediment cup.

▲ WARNING

After installing the sediment cup, check for fuel leaks, and make sure the area is dry before starting the engine. Fuel vapor or spilled fuel may ignite.

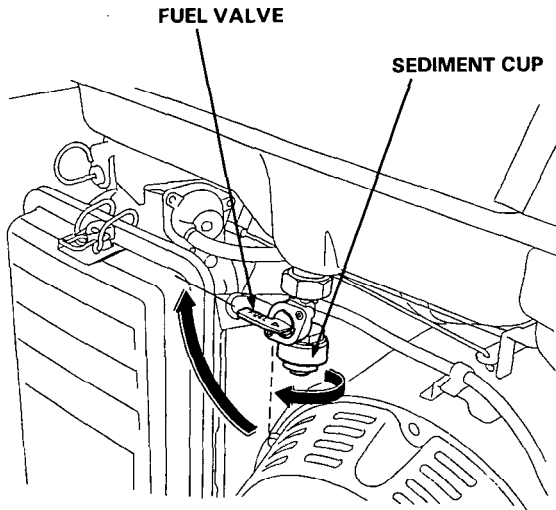

Spark plug service

**Recommended spark plugs: BPR5ES (NGK)
W16EPR-U (ND)**

To ensure proper engine operation, the spark plug must be properly gapped and free of deposits.

▲ WARNING

If the engine has been running, the muffler will be very hot. Be careful not to touch the muffler.

1. Remove the spark plug cap.
2. Clean any dirt from around the spark plug base.
3. Use the wrench supplied in the tool kit to remove the spark plug.

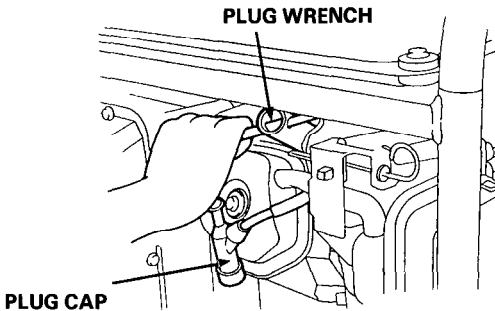

4. Visually inspect the spark plug. Discard it if the insulator is cracked or chipped. Clean the spark plug with a wire brush if it is to be reused.
5. Measure the plug gap with a feeler gauge.
Correct as necessary by carefully bending the side electrode.
The gap should be:
0.70—0.80 mm (0.028—0.031 in)

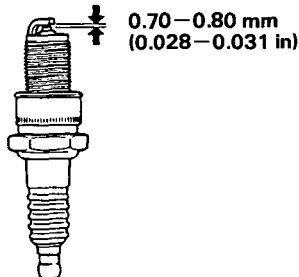

6. Check that the spark plug washer is in good condition, and thread the spark plug in by hand to prevent cross-threading.

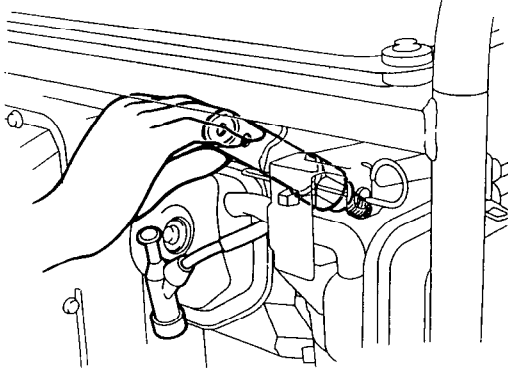

7. After each spark plug is seated, tighten with a spark plug wrench to compress the washer.

NOTE:

If installing a new spark plug, tighten $1/2$ turn after the spark plug seats to compress the washer. If reinstalling a used spark plug, tighten $1/8 - 1/4$ turn after the spark plug seats to compress the washer.

NOTICE

- The spark plug must be securely tightened. An improperly tightened spark plug can become very hot and could damage the engine.
- Never use spark plugs which have an improper heat range. Use only the recommended spark plugs or equivalent.

Spark arrester maintenance

▲ WARNING

If the generator has been running, the muffler will be very hot. Allow it to cool before proceeding.

NOTICE

The spark arrester must be serviced every 100 hours to maintain its efficiency.

Clean the spark arrester as follows:

1. Loosen the screw by the exhaust port of the muffler and remove the spark arrester.
2. Use a brush to remove carbon deposits from the spark arrester screen. Inspect the screen for breaks or tears and replace it if necessary.
3. Install the spark arrester in the reverse order of removal.

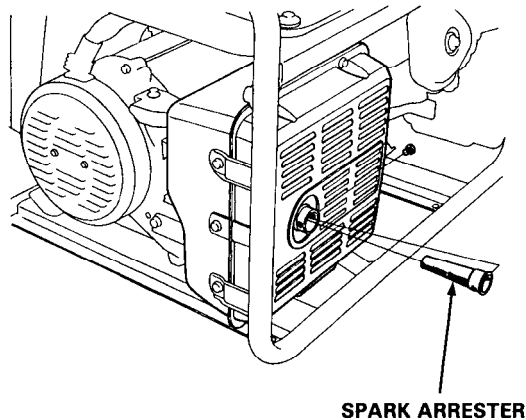

**SPARK ARRESTER
SCREEN**

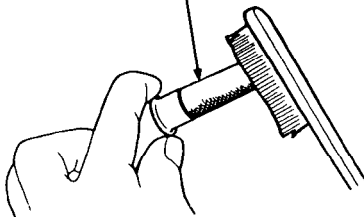

8. TRANSPORTING/STORAGE

▲ WARNING

When transporting the generator, turn the engine switch and the fuel valve OFF and keep the generator level to prevent fuel spillage. Fuel vapor or spilled fuel may ignite.

Before storing the unit for an extended period:

1. Be sure the storage area is free of excessive humidity and dust.
2. Drain the fuel—
 - a. With the fuel valve OFF, remove and empty the sediment cup.

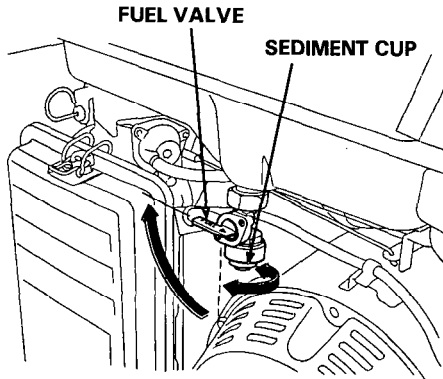

- b. Turn the fuel valve ON, and drain the gasoline in the fuel tank into a suitable container.
- c. Replace the sediment cup and tighten securely.

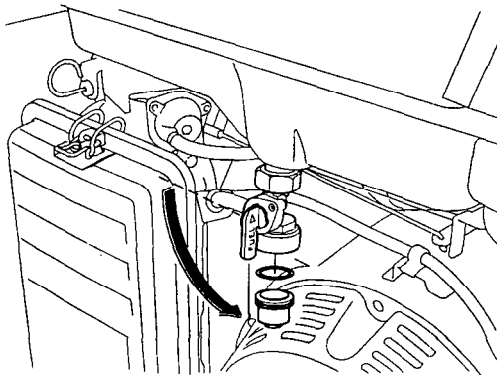

d. Drain the carburetor by loosening the drain screw. Drain the gasoline into a suitable container.

▲ WARNING

Gasoline is extremely flammable and is explosive under certain conditions. Do not smoke or allow flames or sparks in the area

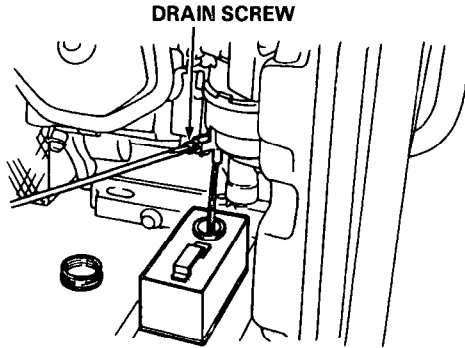

3. Change the engine oil.
4. Remove the spark plug, and pour about a tablespoon of clean engine oil into the cylinder. Crank the engine several revolutions to distribute the oil, then reinstall the spark plug.
5. Slowly pull the starter grip until resistance is felt. At this point, the piston is coming up on its compression stroke and both the intake and exhaust valves are closed. Storing the engine in this position will help to protect it from internal corrosion.

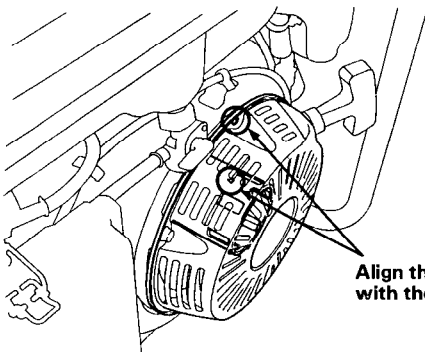

Align the notch on the starter pulley with the hole at the top of recoil starter.

6. Cover the engine to keep out dust.

9. TROUBLESHOOTING

A. When the engine will not start:

1. Is the engine switch on?
2. Does the oil alert lamp flash when the starter is pulled?
3. Is there enough fuel?
4. Is the battery fully charged when starter motor does not start?
5. Are all loads disconnected from the AC receptacles?
6. Is there a spark at the spark plug?
 - a. Remove the spark plug cap. Clean any dust from around the spark plug base, then remove the spark plug.
 - b. Install the spark plug in the plug cap.
 - c. Turn the engine switch on.
 - d. Grounding the side electrode to any engine ground, pull the recoil starter to see if sparks jump across the gap.

▲ WARNING

Be sure there is no spilled fuel around the spark plug. Spilled fuel may ignite. Perform this test in a well ventilated area.

- e. If there are no sparks, replace the plug.
- f. If the new spark plug does not spark, take the generator to an authorized Honda dealer.

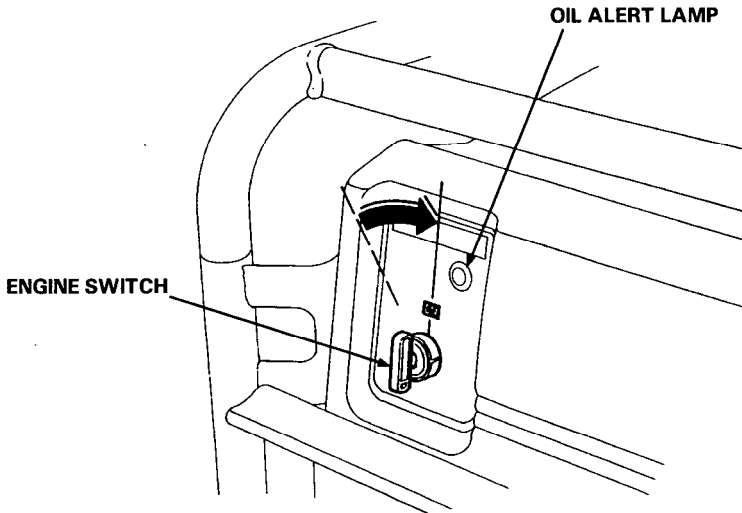

6. Is gasoline reaching the carburetor?

To check, place a suitable container under the drain tube, turn the fuel valve on and loosen the drain screw. Fuel should flow out freely.

If OK, try to start the engine according to the instructions.

▲WARNING

If any fuel is spilled, make sure the area around the spark plug and the generator is dry before starting the engine.

Fuel vapor or spilled fuel may ignite.

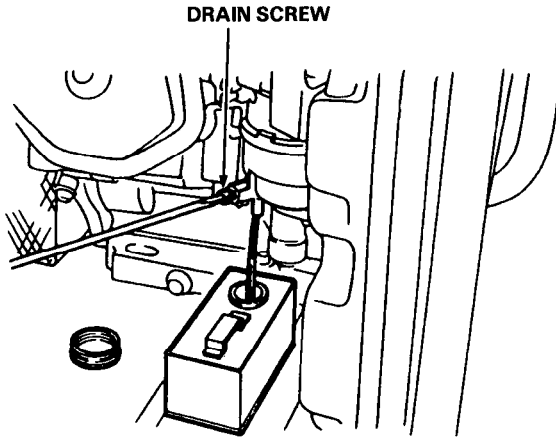

7. If the engine still does not start, take the generator to an authorized Honda dealer.

B. When the engine starts but stops immediately;

1. Check the oil alert lamp.

If the oil alert lamp flashes when the starter is pulled, check the engine oil level and fill with the recommended oil.

2. Re-start the engine.

C. No electricity at the AC receptacles:

1. Is the AC circuit breaker on?

2. Check the electrical appliance or equipment for any defects.

10. WIRING DIAGRAM

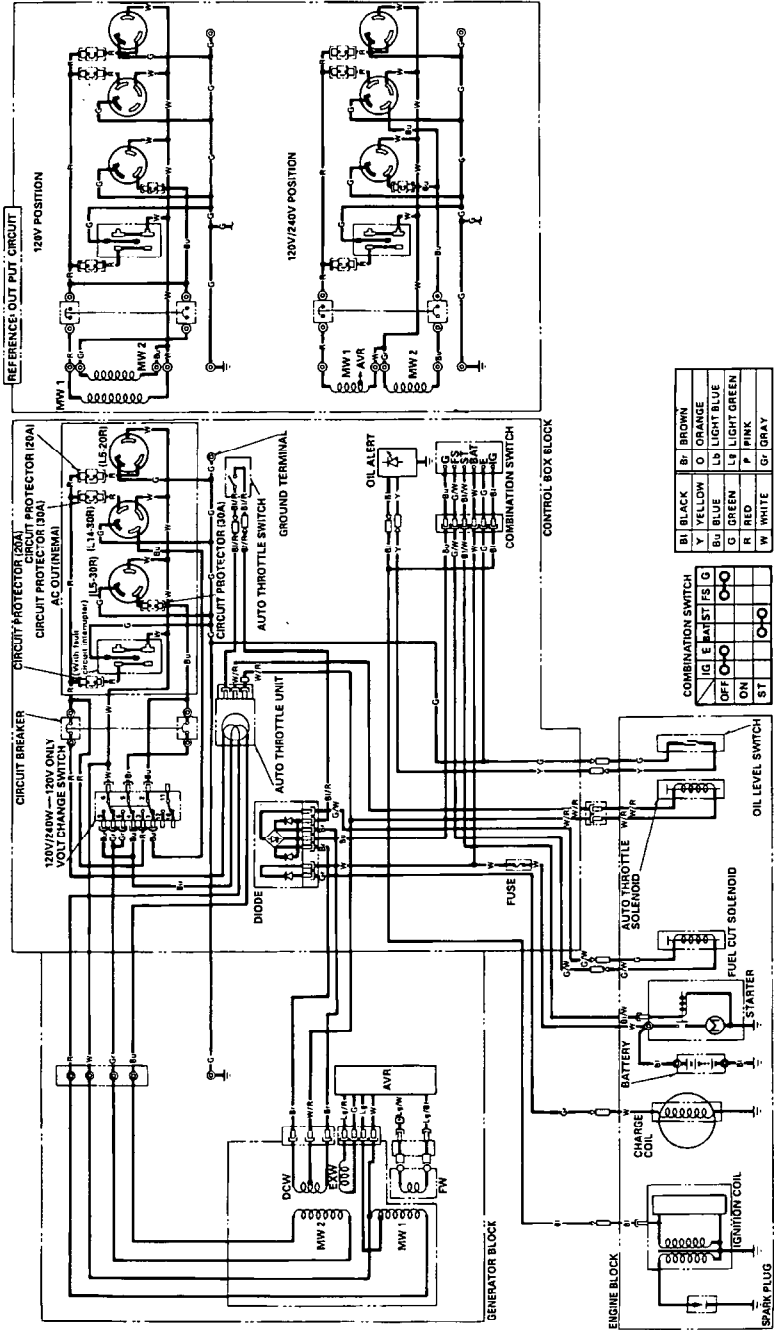

11. SPECIFICATIONS

Dimensions

Power product description code	EZCH
Length	1,200 mm (47.2 in)
Width	665 mm (26.2 in)
Height	720 mm (28.3 in)
Dry weight	98.5 kg (217.2 lbs)

Engine

Engine Type	GX390
Displacement [Bore x Stroke]	389 cm ³ (23.7 cu-in) [88 x 64 mm (3.5 x 2.5 in)
Compression Ratio	8.0 : 1
Engine Speed	3600 r.p.m.
Cooling System	Forced air
Ignition System	Transistorized magneto
Oil Capacity	1.1 ℓ (1.2 US qt , 1.0 Imp qt)
Fuel Tank Capacity	17.0 ℓ (4.49 US gal , 3.74 Imp gal)
Spark Plug	BPR5ES (NGK) , W16EPR-U (ND)

Generator

AC output	
Rated Voltage	120/240 V
Rated Frequency	60 Hz
Rated Ampere	45.8/22.9 A
Rated Output	5.5 kVA
Maximum Output	6.5 kVA

12. HANGER KIT INSTALLATION

1. Remove the upper frame. Install the hanger on it and install the upper frame on the body.

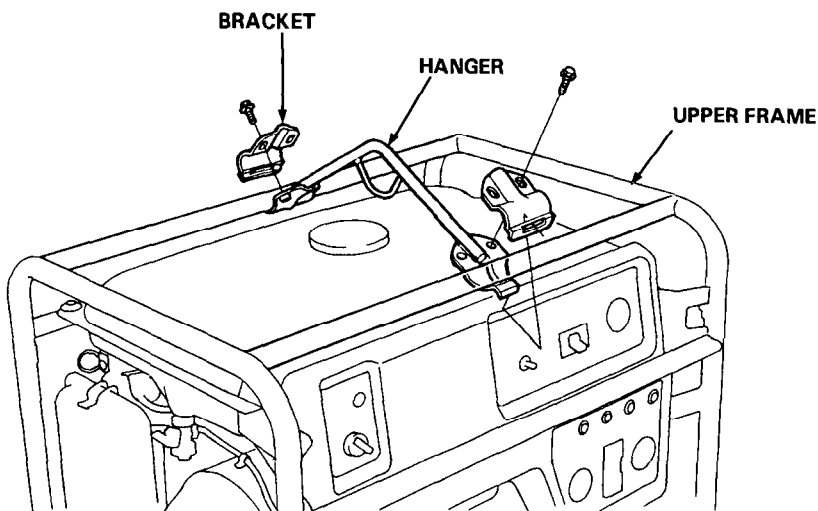

NOTE: Install at near center avoiding to install over the fuel filler cap.

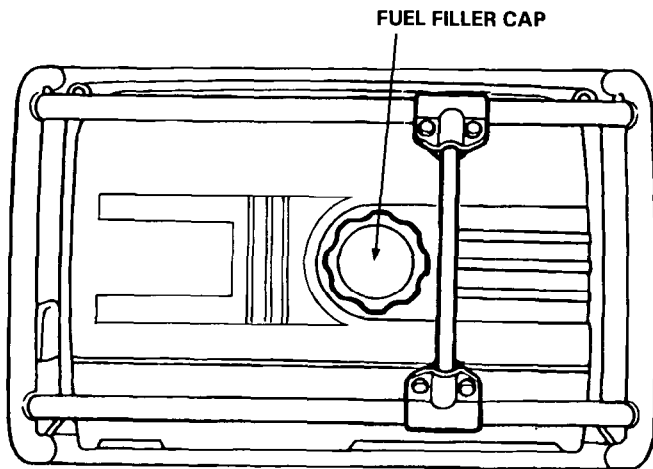

13. 2-WHEEL KIT INSTALLATION

1. Install the two wheels on the axle shaft.
2. Install the axle assembly on the generator using two bolts and nuts.
3. Install the two stands on the under frame.

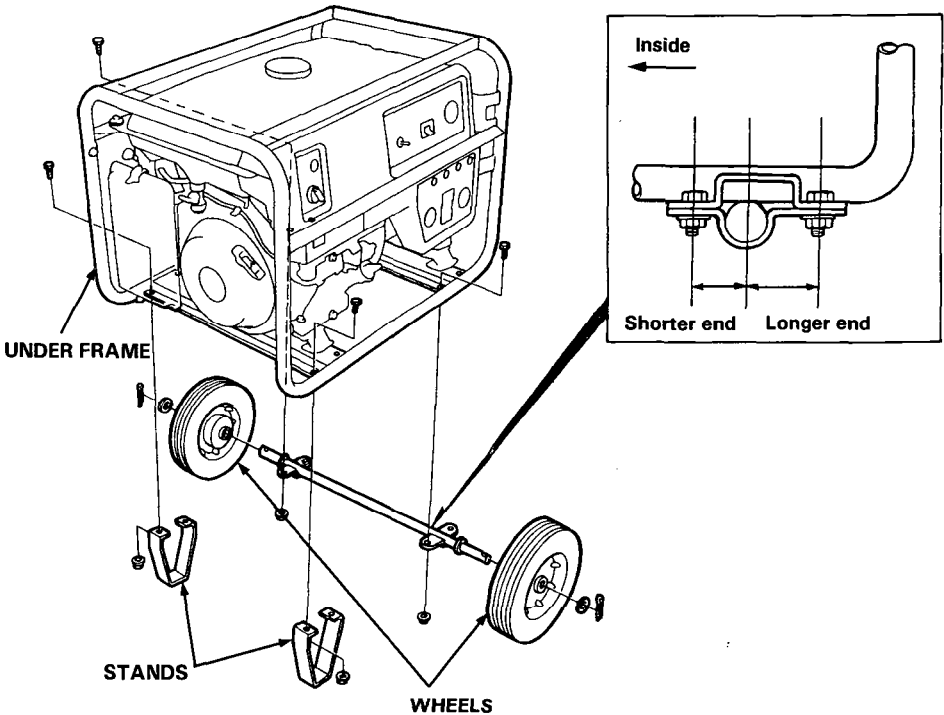

4. Remove the upper frame. Install the two handles with brackets on it using six bolts and install the upper frame on the body using four bolts.

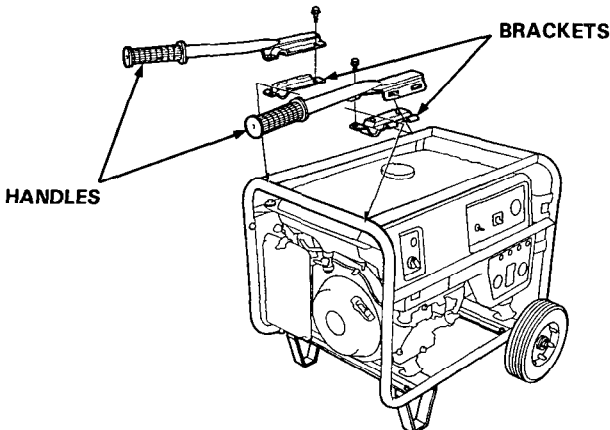

14. BATTERY TRAY KIT

1. Install the battery guard on the frame.
Set the battery tray on the battery guard and tighten the bolts.
2. Route the starter cable under the tank and connect it to the starter solenoid.
3. Connect the ground cable to the generator rear housing.
4. Set the battery on the battery tray and secure with the battery bracket.
Connect the starter cable to the battery positive (+) terminal first, then to the negative (−) terminal. When disconnecting, disconnect at the battery negative (−) terminal first.
5. Install the battery guard plate on the battery guard.

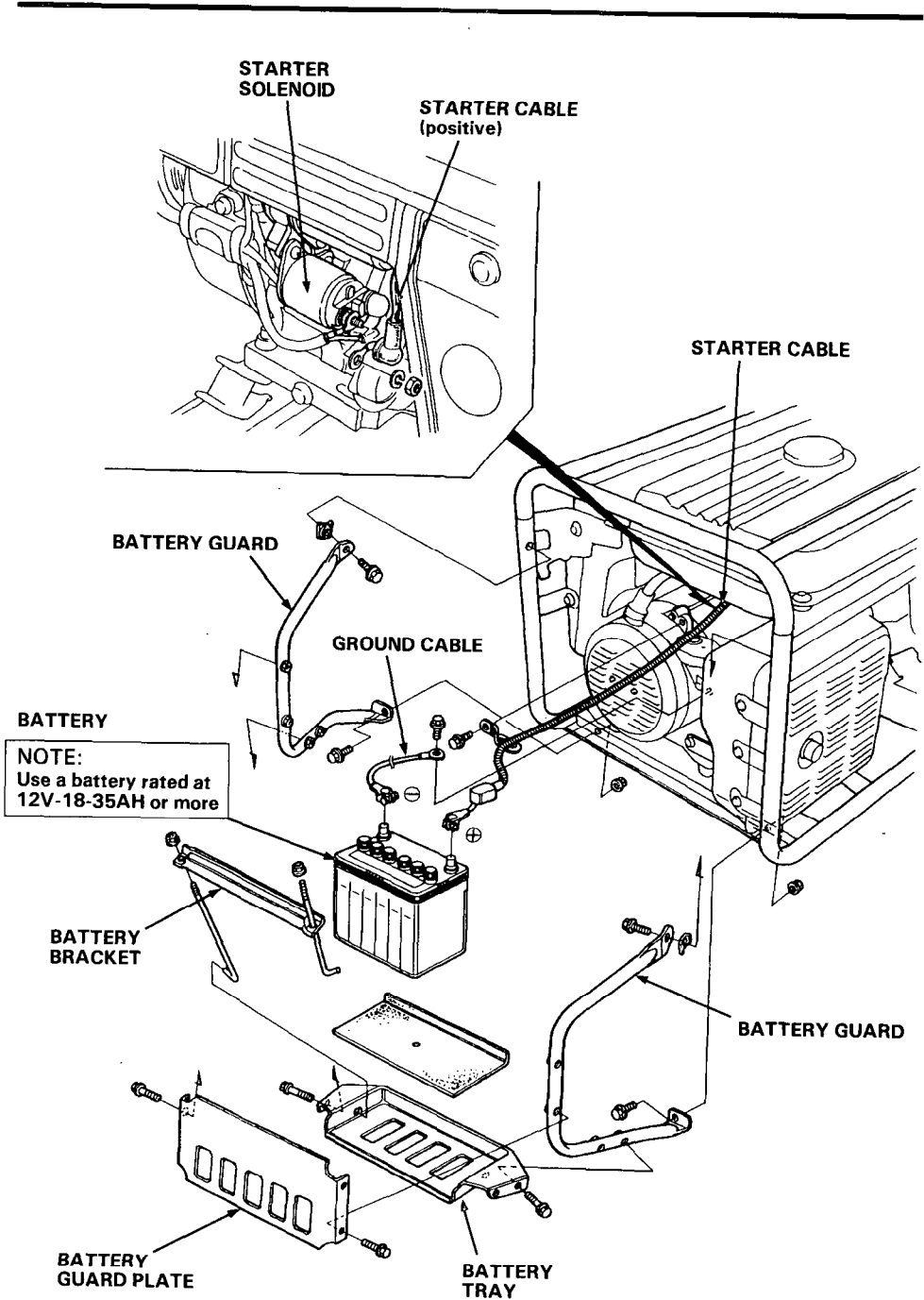

15. WARRANTY SERVICE

Owner satisfaction

Your satisfaction and goodwill are important to your dealer and to us. All Honda warranty details are explained in the Distributor's Limited Warranty. Normally, any problems concerning the product will be handled by your dealer's service department. If you have a warranty problem that has not been handled to your satisfaction, we suggest you take the following action:

- Discuss your problem with a member of dealership management. Often complaints can be quickly resolved at that level. If the problem has already been reviewed with the Service Manager, contact the owner of the dealership or the General Manager.
- If your problem still has not been resolved to your satisfaction, contact:

American Honda Motor Co., Inc.
P.O. Box 100021
Duluth, Georgia 30136-9421
Telephone: (404) 497-6400

We will need the following information in order to assist you:

- Your name, address, and telephone number
- Product model and serial number
- Date of purchase
- Dealer name and address
- Nature of the problem

After reviewing all the facts involved, you will be advised of what action can be taken. Please bear in mind that your problem will likely be resolved at the dealership, using the dealer's facilities, equipment, and personnel, so it is very important that your initial contact be with the dealer.

Your purchase of a Honda product is greatly appreciated by both your dealer and American Honda Motor Co., Inc. We want to assist you in every way possible to assure your complete satisfaction with your purchase.

MEMO

MEMO

HONDA
HONDA MOTOR CO., LTD. TOKYO, JAPAN

31ZD1600
00X31-ZD1-6000

(AH) (M) (HC) 6009102M
PRINTED IN JAPAN