

**HONDA**

**Power**

**Equipment**

# Owner's Manual

## EX3300S/4500S

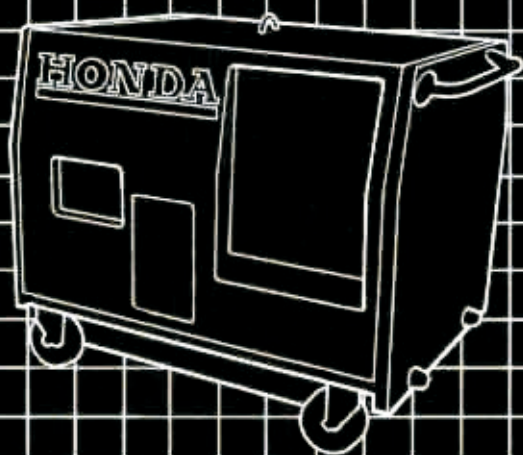

**▲ WARNING**

The generator is a potential source of electrical shock if misused. Do not expose the generator to moisture, rain or snow. Do not let the generator get wet, and do not operate it with wet hands.

---

Thank you for purchasing a Honda generator.

This manual covers the operation and maintenance of EX3300S and EX4500S generators. All information in this publication is based on the latest product information available at the time of printing. The illustrations in this manual are based on the EX4500S generator.

Honda Motor Co., Ltd. reserves the right to make changes at any time without notice and without incurring any obligation.

No part of this publication may be reproduced without written permission.

This manual should be considered a permanent part of the generator and should remain with the generator if it is resold.

This generator is equipped with a U.S.D.A. qualified spark arrester which requires periodic maintenance to ensure its effectiveness. It is illegal in some areas to operate an engine without a spark arrester; check local laws and regulations.

Pay special attention to statements preceded by the following words:

**⚠ DANGER:** Indicates severe personal injury or death will result if instructions are not followed.

**⚠ WARNING** Indicates a strong possibility of severe personal injury or loss of life if instructions are not followed.

**CAUTION:** Indicates a possibility of personal injury or equipment damage if instructions are not followed.

**NOTE:** Gives helpful information.

If a problem should arise, or if you have any questions about the generator, consult an authorized Honda dealer.

**⚠ WARNING** Honda generators are designed to give safe and dependable service if operated according to instructions. Read and understand this Owner's Manual before operating the generator. Failure to do so could result in personal injury or equipment damage.

# CONTENTS

---

## CONTENTS

1. GENERATOR SAFETY .....	3
2. COMPONENT IDENTIFICATION .....	6
3. PRE-OPERATION CHECK .....	8
4. STARTING THE ENGINE .....	12
5. GENERATOR USE .....	14
• High altitude operation .....	18
6. STOPPING THE ENGINE .....	19
7. MAINTENANCE .....	20
8. TRANSPORTING/STORAGE .....	30
9. TROUBLESHOOTING .....	31
10. WIRING DIAGRAM .....	33
11. SPECIFICATIONS .....	35
12. INSTALLATION OF OPTIONAL PARTS .....	36
13. WARRANTY SERVICE .....	38

# 1. GENERATOR SAFETY

## **⚠ WARNING**

- Place the generator on a firm, level surface; avoid loose sand or snow. If the generator is tilted or overturned, fuel spillage may result. Also, if the generator is overturned or sinks into a soft surface, sand, dirt, or water may enter the generator.
- To prevent fire hazards and to provide adequate ventilation, keep the generator at least 1 meter (3 feet) away from buildings and other equipment during operation. Do not place flammable objects close to the generator.
- Know how to stop the generator quickly, and understand the operation of all the controls. Never permit anyone to operate the generator without proper instructions.
- The generator is a potential source of electrical shock if misused. Do not expose the generator to moisture, rain or snow. Do not let the generator get wet, and do not operate it with wet hands.
- Do not allow children to operate the generator. Keep children and pets away from the area of operation.
- Gasoline is extremely flammable and is explosive under certain conditions. Do not smoke or allow flames or sparks where the generator is refueled or where gasoline is stored. Refuel in a well-ventilated area with the engine stopped.
- Exhaust gas contains poisonous carbon monoxide. Avoid inhalation of exhaust gasses. Never run the engine in a closed garage or confined area.
- The muffler becomes very hot during operation and remains hot for a while after stopping the engine. Be careful not to touch the muffler while it is hot. Let the engine cool before storing the generator indoors.
- Connections for standby power to a building's electrical system must be made by a qualified electrician and must comply with all applicable laws and electrical codes. Improper connections can allow electrical current from the generator to backfeed into the utility lines. Such backfeed may electrocute utility company workers or others who contact the lines during a power outage, and when utility power is restored, the generator may explode, burn, or cause fires in the building's electrical system.

Read these labels before you operate the generator.

**HOT · EXHAUST  
ECHAPPEMENT · CHAUD** ↓

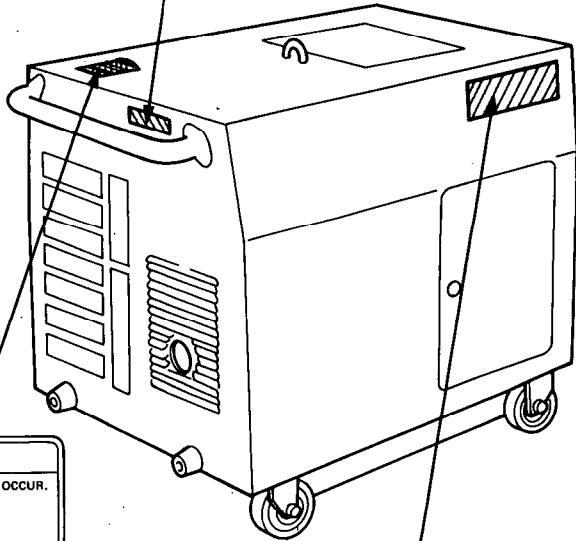

**⚠ WARNING**  
ELECTROCUTION OR PROPERTY DAMAGE CAN OCCUR.  
DO NOT CONNECT THIS GENERATOR TO ANY  
BUILDING'S ELECTRICAL SYSTEM UNLESS AN  
ISOLATION SWITCH HAS BEEN INSTALLED  
BY A LICENSED ELECTRICIAN.  
READ OWNER'S MANUAL CAREFULLY.

<b>EX4500S</b>		HONDA MOTOR CO., LTD.		MADE IN JAPAN Ⓐ	
<b>CAUTION</b>		<b>A C</b>		<b>D C</b>	
BE SURE TO FILL CRANKCASE WITH RECOMMENDED OIL BEFORE USING. FOR DETAILED EXPLANATION, SEE THE OWNER'S MANUAL.		VOLTAGE 120/240V FREQUENCY 60Hz RATED OUTPUT 4.0kVA MAX. OUTPUT 4.5kVA PHASE 1Ø		VOLTAGE 12V CURRENT 8.3A	
				FUEL GASOLINE (PETROL)	

<b>EX3300S</b>		HONDA MOTOR CO., LTD.		MADE IN JAPAN Ⓐ	
<b>CAUTION</b>		<b>A C</b>		<b>D C</b>	
BE SURE TO FILL CRANKCASE WITH RECOMMENDED OIL BEFORE USING. FOR DETAILED EXPLANATION, SEE THE OWNER'S MANUAL.		VOLTAGE 120/240V FREQUENCY 60Hz RATED OUTPUT 3.0kVA MAX. OUTPUT 3.3kVA PHASE 1Ø		VOLTAGE 12V CURRENT 8.3A	
				FUEL GASOLINE (PETROL)	

**WARNING** DO NOT USE INDOORS. EXHAUST GAS CONTAINS POISONOUS CARBON MONOXIDE.

**ATTENTION** NE PAS UTILISER DANS UN ENDROIT FERME A CAUSE DU RISQUE D'EMPOISONNEMENT DU GAZ.

**ATENCION** NO LO USE EN LUGARES CERRADOS PORQUE EL MONOXIDE DE CARBONO ES VENENOSO.

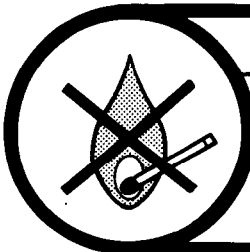
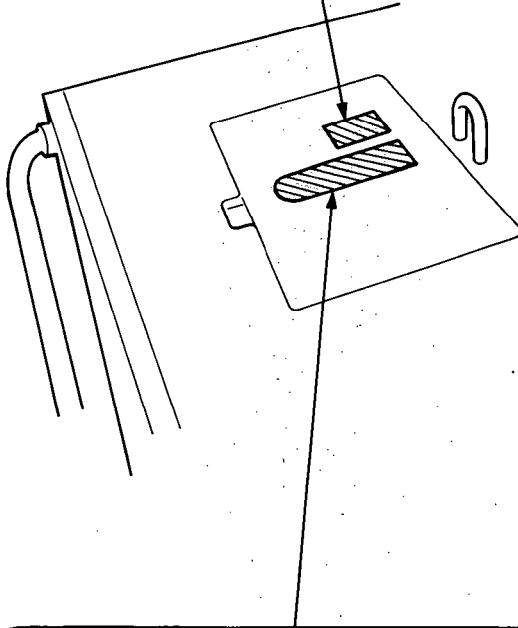

■CHECK FOR SPILLED FUEL OR FUEL LEAKS.  
STOP ENGINE BEFORE REFUELING.

■CONTROLLER QU'IL N'Y A NI FUITE NI ESSENCE  
REPAÑDUE SUR L'APPAREIL.  
ARRETER LE MOTEUR AVANT DE REFAIRE LE PLEIN.

■INSPECCIONAR PARA COMBUSTIBLE DERRAMADO  
O ESCAPE.  
PARAR MOTOR ANTES DE ÉCHAR.

## 2. COMPONENT IDENTIFICATION

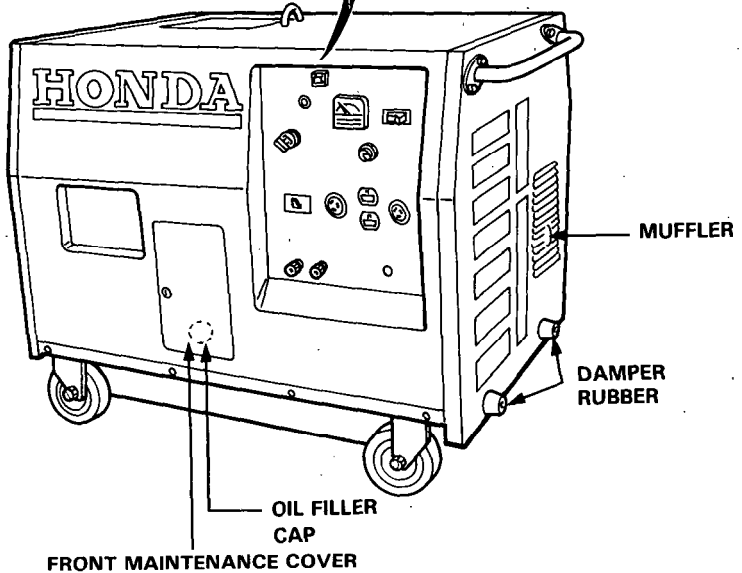
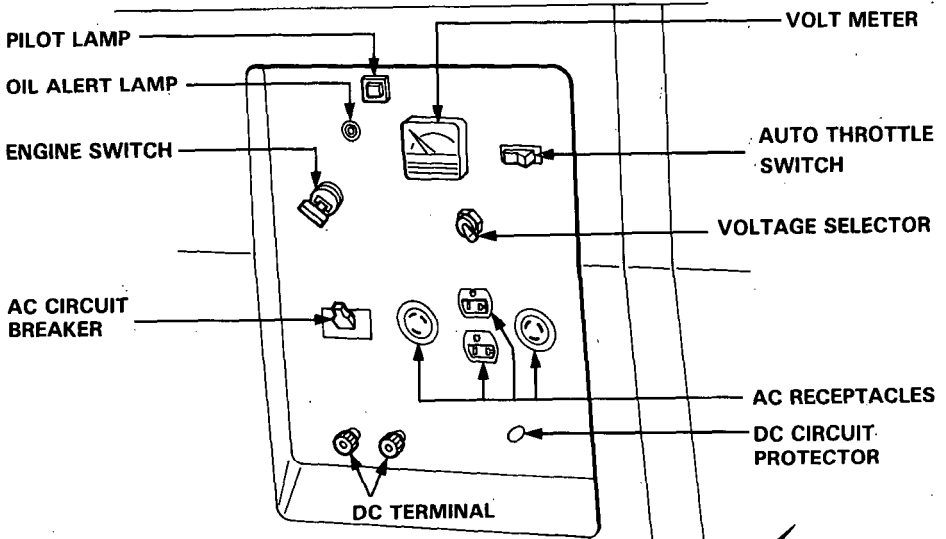



UPPER MAINTENANCE COVER

FUEL TANK CAP

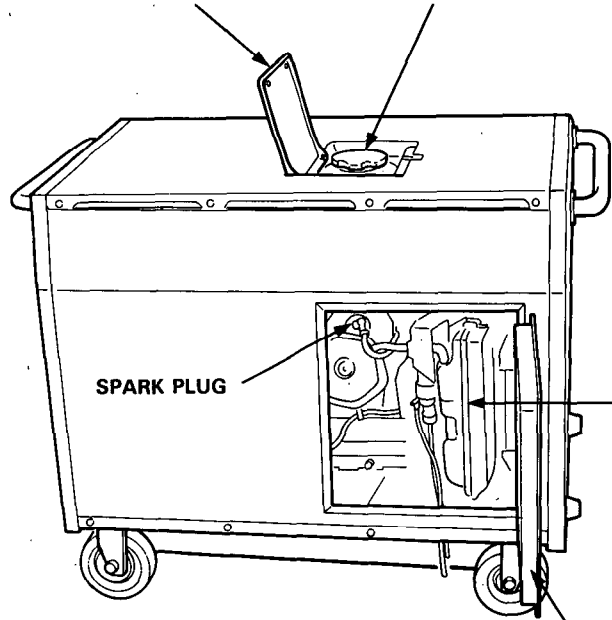

SPARK PLUG

AIR CLEANER

REAR MAINTENANCE COVER

### 3. PRE-OPERATION CHECK

**CAUTION:** Check the generator on a level surface with the engine stopped.

#### 1. ENGINE OIL

**CAUTION:** Engine oil is a major factor affecting engine performance and service life. Non-detergent or 2-stroke engine oils are not recommended.

Use Honda 4-stroke oil, or an equivalent high detergent, premium quality motor oil certified to meet or exceed U.S. automobile manufacturers' requirements for Service Classification SG, SF/CC, CD. Motor oils classified SG, SF/CC, CD will show this designation on the container.

SAE 10W/30 is recommended for general, all-temperature use. Other viscosities shown in the chart may be used when the average temperature in your area is within the indicated range.

Remove the oil filler cap, and wipe the dipstick with a clean rag. Check the oil level by inserting the dipstick in the filler hole without screwing it in. If the level is low, fill to the top of the oil filler neck with the recommended oil.

**NOTE:** The Oil Alert System will automatically stop the engine before the oil level falls below the safe limit. However, to avoid the inconvenience of an unexpected shutdown, it is still advisable to visually inspect the oil level regularly.

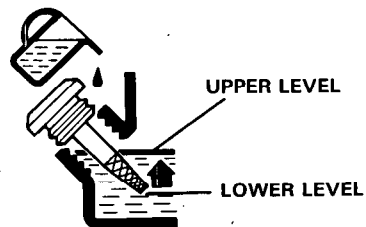
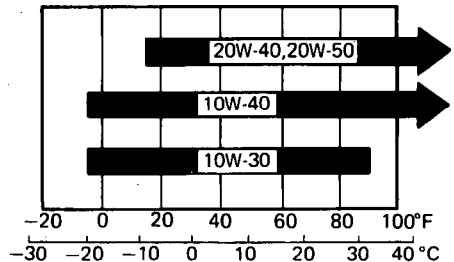
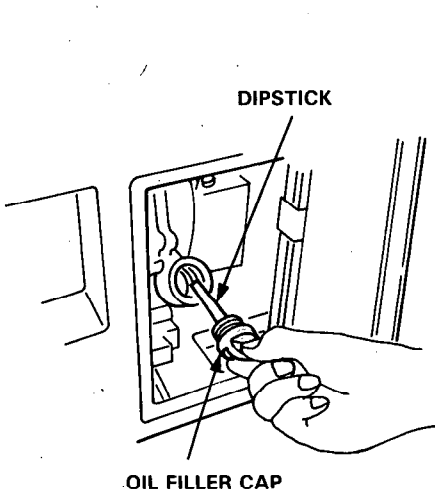

## 2. FUEL

Check the fuel gauge and refill the tank if the fuel level is low.

Your engine is designed to use any gasoline that has a pump octane number ( $\frac{R+M}{2}$ ) of 86 or higher, or that has a research octane number of 91 or higher. Gasoline pumps at service station normally display the pump octane number.

We recommend that you use unleaded fuel because it produces fewer engine and spark plug deposits and extends the life of exhaust system components.

Never use stale or contaminated gasoline or an oil/gasoline mixture. Avoid getting dirt, dust or water in the fuel tank. Use of a lower octane gasoline can cause persistent "pinging" or heavy "spark knock" (a metallic rapping noise) which, if severe, can lead to engine damage.

**CAUTION:** If "spark knock" or "pinging" occurs at a steady engine speed under normal load, change brands of gasoline. If spark knock or pinging persists, consult your authorized Honda dealer. Failure to do so is considered misuse, and damage caused by misuse is not covered by Honda's Limited Warranty.

Occasionally you may experience light spark knock while operating under heavy loads. This is no cause for concern, it simply means your engine is operating efficiently.

**Fuel tank capacity: 19 l (5.02 US gal)**

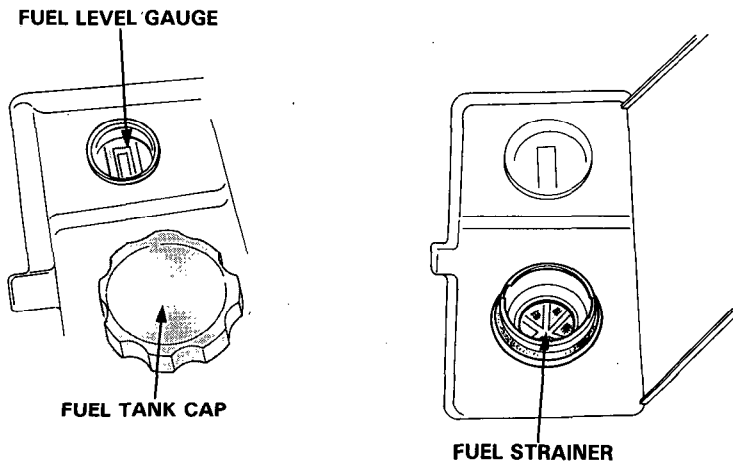

---

**▲ WARNING**

- Gasoline is extremely flammable and is explosive under certain conditions.
  - Refuel in a well-ventilated area with the engine stopped. Do not smoke or allow flames or sparks in the area where the engine is refueled or where gasoline is stored.
  - Do not overfill the fuel tank (there should be no fuel in the filler neck). After refueling, make sure the tank cap is closed properly and securely.
  - Be careful not to spill fuel when refueling. Spilled fuel or fuel vapor may ignite. If any fuel is spilled, make sure the area is dry before starting the engine.
  - Avoid repeated or prolonged contact with skin or breathing of vapor.
- KEEP OUT OF REACH OF CHILDREN.**

## **GASOLINES CONTAINING ALCOHOL**

If you decide to use a gasoline containing alcohol (gasohol), be sure it's octane rating is at least as high as that recommended by Honda. There are two types of "gasohol": one containing ethanol, and the other containing methanol. Do not use gasohol that contains more than 10% ethanol. Do not use gasoline containing methanol (methyl or wood alcohol) that does not also contain cosolvents and corrosion inhibitors for methanol. Never use gasoline containing more than 5% methanol, even if it has cosolvents and corrosion inhibitors.

### **NOTE:**

- Fuel system damage or engine performance problems resulting from the use of fuels that contain alcohol is not covered under the warranty. Honda cannot endorse the use of fuels containing methanol since evidence of their suitability is as yet incomplete.
- Before buying fuel from an unfamiliar station, try to find out if the fuel contains alcohol, if it does, confirm the type and percentage of alcohol used. If you notice any undesirable operating symptoms while using a gasoline that contains alcohol, or one that you think contains alcohol, switch to a gasoline that you know does not contain alcohol.

### 3. Check the battery.

The electrolyte level must be maintained between the UPPER and LOWER level marks. If the electrolyte level is near the LOWER mark, add distilled water.

#### ▲ WARNING

- The battery gives off explosive gases; keep sparks, flames and cigarettes away. Provide adequate ventilation when charging or using batteries in an enclosed space.
- The battery contains sulfuric acid (electrolyte). Contact with skin or eyes may cause severe burns. Wear protective clothing and a face shield.
  - If electrolyte gets on your skin, flush with water.
  - If electrolyte gets in your eyes, flush with water for at least 15 minutes and call a physician immediately.
- Electrolyte is poisonous.
  - If swallowed, drink large quantities of water or milk and follow with milk of magnesia or vegetable oil and call a physician.
- **KEEP OUT OF REACH OF CHILDREN.**

#### CAUTION:

- Use only distilled water in the battery. Tap water will shorten the service life of the battery.
- Filling the battery above the UPPER LEVEL line may cause the electrolyte to overflow, resulting in corrosion to engine or nearby parts. Immediately wash off any spilled electrolyte.

Check the battery terminals to be sure the cables are tightened and free of corrosion. Remove any corrosion, and coat the terminals and cable ends with grease.

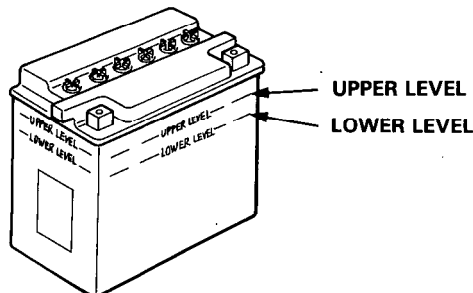

## 4. STARTING THE ENGINE

**CAUTION:** When starting the generator after adding fuel for the first time, after long-term storage, or after running out of fuel, turn the engine switch to the "ON" position, then wait for 10 to 20 seconds before starting the engine.

1. Turn off the AC circuit breaker.

AC CIRCUIT BREAKER

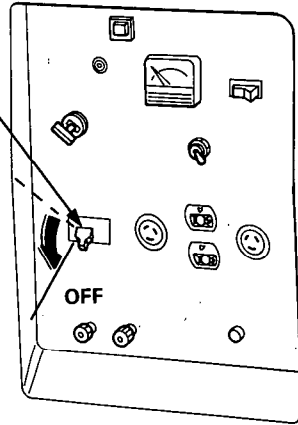

2. Make sure the auto-throttle switch is off, or more time will be required for warm up.

AUTO THROTTLE SWITCH

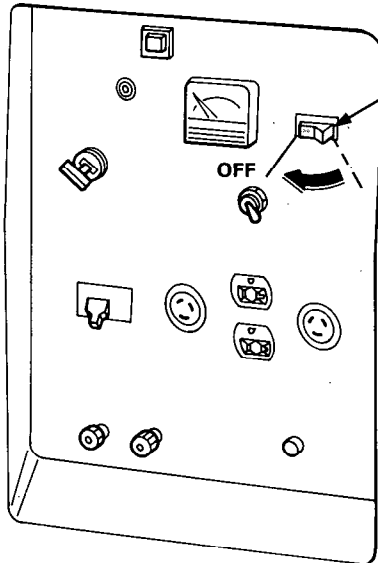

3. Turn the engine switch to the START position and hold it there until the engine starts.

**NOTE:** Do not use the electric starter for more than 5 seconds at a time. If the engine fails to start, release the switch and wait 10 seconds before operating the starter again.

When the engine starts, allow the engine switch return to the ON position.

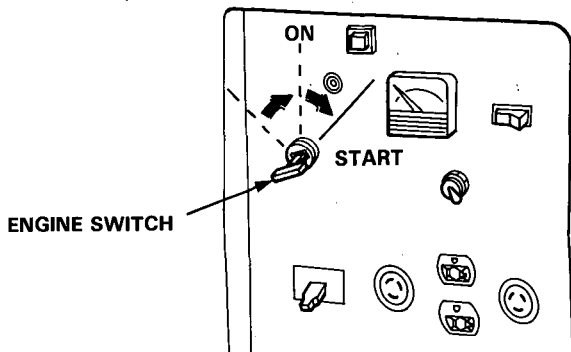

4. If auto-throttle will be used, turn the switch to "AUTO" after the engine has warmed up.

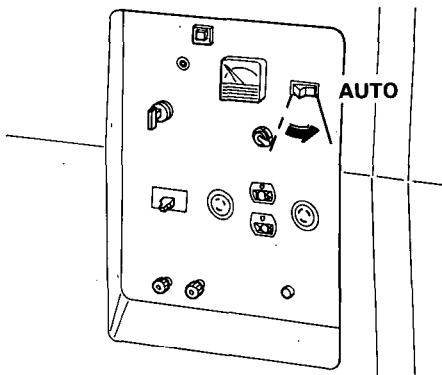

**NOTE:**

- AUTO is recommended to minimize fuel consumption.
- The auto-throttle system will not respond to electrical loads of less than 1 ampere.
- The system is not effective for use with appliance that requires only momentary power. To avoid extended warm-up periods, keep the switch OFF until the engine reaches operating temperature.

## 5. GENERATOR USE

---

### ▲ WARNING

- To prevent electrical shock from faulty appliances, the generator should be grounded. Connect a length of heavy wire between the ground terminal and an external ground source.
- Connections for standby power to a building's electrical system must be made by a qualified electrician and must comply with all applicable laws and electrical codes. Improper connections can allow electrical current from the generator to backfeed into the utility lines. Such backfeed may electrocute utility company workers or others who contact the lines during a power outage, and when utility power is restored, the generator may explode, burn, or cause fires in the building's electrical system.

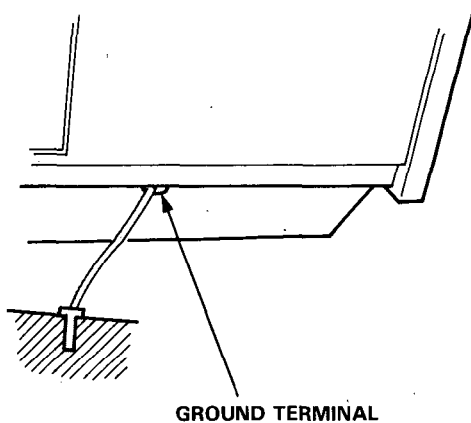

### CAUTION

- Limit operation requiring maximum power (4.5 kVA for EX4500S, 3.3 kVA for EX3300S) to 30 minutes.  
For continuous operation, do not exceed the rated power of 4.0 kVA for EX4500S, 3.0 kVA for EX3300S.  
In either case, the total wattage of all appliances connected must be considered.
- Most appliance motors require more than their rated wattage for start-up.
- Do not exceed the current limit specified for any one receptacle.



### Auto-throttle System

With the switch in the AUTO position, engine speed is automatically reduced to an idle when all loads are turned off or disconnected. When appliances are turned on or reconnected, the engine resumes the rated speed. At OFF, the auto-throttle system does not operate.

**NOTE:**

- AUTO is recommended to minimize fuel consumption when no load is applied.
- The auto-throttle system will not respond to electrical loads of less than 1 ampere.
- The system is not-effective for use with appliances that require only momentary power. To avoid extended warm-up periods, keep the switch OFF until the engine reaches operating temperature.

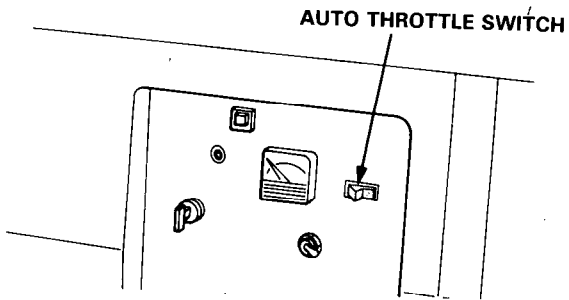

### Oil Alert System

The Oil Alert system is designed to prevent engine damage caused by an insufficient amount of oil in the crankcase. Before the oil level in the crankcase can fall below a safe limit, the Oil Alert system will automatically shut down the engine (the engine switch will remain in the ON position). If the Oil Alert system shuts down the engine, the Oil Alert lamp will flash when you operate the starter, and the engine will not run. If this occurs, add engine oil (p. 8).

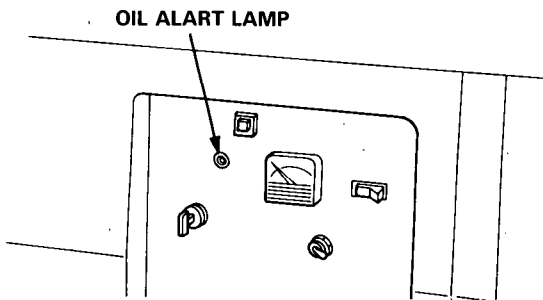

## AC operation

1. Start the engine.
2. Turn the voltage selector switch to either position as required.

NOTE: With the voltage selector switch in the "120V/240V" position, you can use the 120V and 240V receptacles simultaneously. If you are not using the 240V receptacle, but you require more power from the 120V twist-lock receptacle, then turn the switch to the "120V" position.

3. Switch on the AC circuit breaker.
4. Plug in the appliance.

### CAUTION:

- Be sure that appliances do not exceed the generator's rated load capacity for more than 30 minutes, and that they never exceed the maximum load capacity. Substantial overloading will switch off the circuit breaker. Marginal overloading may not switch off the circuit breaker, but it will shorten the service life of the generator.
- If an overloaded circuit causes the AC circuit breaker to switch off, reduce the electrical load on the circuit, and wait a few minutes before resetting the circuit breaker.
- Be sure that all appliances are in good working order before connecting them to the generator. If an appliance begins to operate abnormally, becomes sluggish, or stops suddenly, turn off the circuit breaker and the generator engine switch immediately. Then disconnect the appliance and examine it for signs of malfunction.

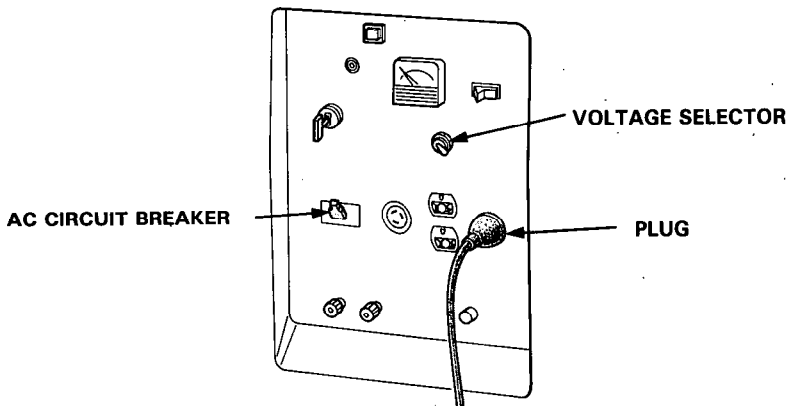

## DC application

The DC terminals may be used for charging 12 bolt automotive-type batteries only.

1. Connect both charging cables to the battery terminals and connect the positive (+) cable to the generator's positive (+) DC terminal.
2. Start the generator.
3. Carefully connect the negative (-) charging cable to the generator's negative (-) DC terminal.

### ▲WARNING

- The battery gives off explosive gases; keep sparks, flames and cigarettes away. Provide adequate ventilation when charging or using batteries in an enclosed space.
- The battery contains sulfuric acid (electrolyte). Contact with skin or eyes may cause severe burns. Wear protective clothing and a face shield.
  - If electrolyte gets on your skin, flush with water.
  - If electrolyte gets in your eyes, flush with water for at least 15 minutes and call a physician immediately.
- Electrolyte is poisonous.
  - If swallowed, drink large quantities of water or milk and follow with milk of magnesia or vegetable oil and call a physician.
- **KEEP OUT OF REACH OF CHILDREN.**
- To prevent the possibility of creating a spark near the battery, connect charging cables first to the battery, then to the generator. Disconnect cables first at the generator.
- Before connecting charging cables to a battery that is installed in a vehicle, disconnect the vehicle's grounded battery cable. Reconnect the vehicle's grounded battery cable after the charging cables are removed. This procedure will prevent the possibility of a short circuit and sparks if you make accidental contact between a battery terminal and the vehicle's frame or body.

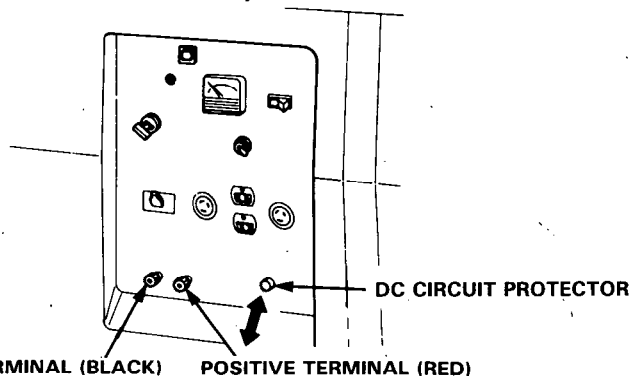

---

## CAUTION

- Be careful to connect the charging cables to the correct battery and generator terminals (positive to positive and negative to negative). If the charging cables are connected positive to negative, it may cause serious battery or generator damage.
- Do not attempt to start an automobile engine with the generator still connected to the battery; this may damage the generator.

## NOTE:

- The DC terminals may be used while the AC power is in use.
- An overloaded DC circuit will trip the DC circuit protector (green indicator in the push button pops out). If this happens, wait a few minutes before pushing the circuit protector to resume operation.
- **High altitude operation**

At high altitude, the standard carburetor air-fuel mixture will be excessively rich. Performance will decrease, and fuel consumption will increase.

High altitude performance can be improved by installing a smaller diameter main fuel jet in the carburetor and readjusting the pilot screw. If you always operate the generator at altitudes higher than 6,000 feet above sea level, have your authorized Honda Generator dealer perform these carburetor modifications.

Even with suitable carburetor jetting, engine horsepower will decrease approximately 3.5% for each 1,000 foot increase in altitude. The affect of altitude on horsepower will be greater than this if no carburetor modification is made.

**CAUTION:** Operation of the generator at an altitude lower than the carburetor is jetted for may result in reduced performance, overheating, and serious engine damage caused by an excessively lean air/fuel mixture.

## 6. STOPPING THE ENGINE

**NOTE:** To stop the engine in an emergency, turn the engine switch to the OFF position.

In normal use:

1. Move the AC circuit breaker to the OFF position.  
Disconnect DC battery charging cables.

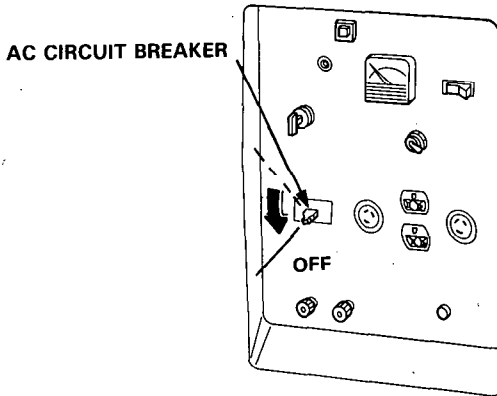

2. Turn the engine switch to the OFF position.

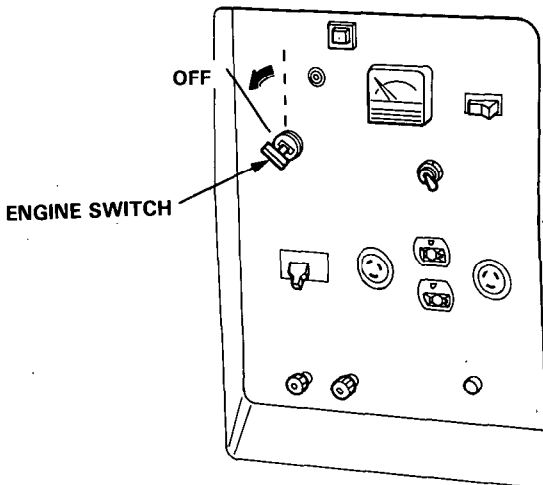

## 7. MAINTENANCE

Periodic maintenance and adjustment is necessary to keep the generator in good operating condition. Perform the service and inspection scheduled in the table on the following page.

**WARNING** Shut off the engine before performing any maintenance. If the engine must be run, make sure the area is well ventilated. Exhaust gas contains poisonous carbon monoxide.

**CAUTION:** Use only genuine Honda parts or their equivalent for maintenance or repair. Replacement parts which are not of equivalent quality may damage the generator.

### Maintenance Schedule

REGULAR SERVICE PERIOD Performed at every indicated month or operating hour interval, whichever comes first.		EACH USE	FIRST MONTH OR 20 HRS (3)	EVERY 3 MONTHS OR 50 HRS (3)	EVERY 6 MONTHS OR 100 HRS (3)	EVERY YEAR OR 300 HRS (3)
ITEM						
Engine oil	Check level	○				
	Change		○		○	
Air cleaner	Check	○				
	Clean			○(1)		
Battery electrolyte	Check level	○				
	Check level and gravity				○	
Spark plug	Clean-Readjust				○	
Spark arrester	Clean				○	
Fuel sediment cup	Clean				○	
Valve clearance	Check-Readjust					○(2)
Fuel tank and filter	Clean					○(2)
Fuel line	Check (Replace if necessary)		Every 3 years (2)			

NOTE: (1) Service more frequently when used in dusty areas.

(2) These items should be serviced by an authorized Honda dealer, unless the owner has the proper tools and is mechanically proficient. See the Honda Shop Manual.

(3) For professional commercial use, log hours of operation to determine proper maintenance intervals.

## Tool kit

The tools supplied with the generator will help you to perform the owner-maintenance procedures listed on page 20. Always keep this tool kit with the generator.

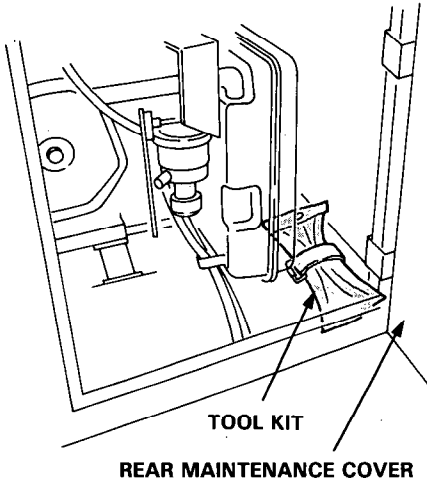

### TOOL KIT

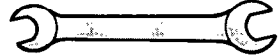

10 x 12 mm WRENCH



PLUG WRENCH



PLUG WRENCH HANDLE



FLAT SCREWDRIVER

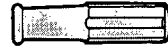

DRIVER GRIP

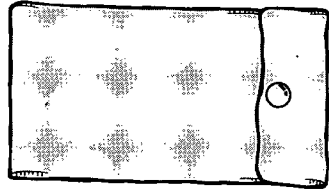

TOOL BAG

---

## Changing oil

Drain the oil while the engine is still warm to assure rapid and complete draining.

1. Open the front maintenance cover.
2. Remove the drain bolt and filler cap, and drain the oil. Retighten the bolt securely.
3. Refill with the recommended oil (see page 8) and check the level.
4. Close and latch the front maintenance cover.

**OIL CAPACITY: 1.1ℓ (1.16 US qt)**

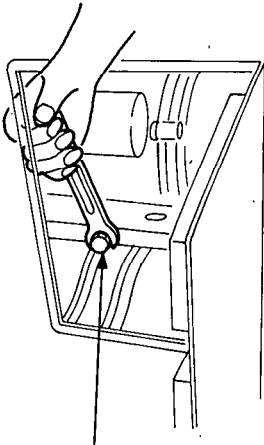

OIL DRAIN BOLT

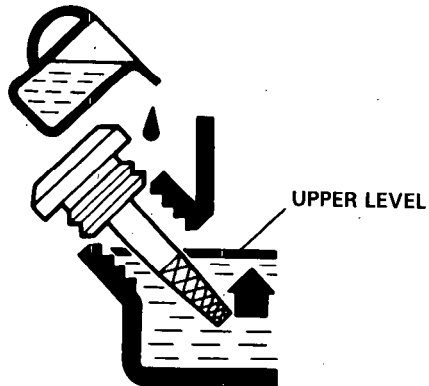

**CAUTION:** Used motor oil may cause skin cancer if repeatedly left in contact with the skin for prolonged periods. Although this is unlikely unless you handle used oil on a daily basis, it is still advisable to thoroughly wash your hands with soap and water as soon as possible after handling used oil.

**NOTE:** Please dispose of used motor oil in a manner that is compatible with the environment. We suggest you take it in a sealed container to your local service station for reclamation. Do not throw it in the trash or pour it on the ground.



## Air cleaner service

A dirty air cleaner will restrict air flow to the carburetor. To prevent carburetor malfunction, service the air cleaner regularly (page 20). Service more frequently when operating the generator in extremely dusty areas.

**▲ WARNING** Never use gasoline or low flash point solvents for cleaning the air cleaner element. A fire or explosion could result.

**CAUTION:** Never run the generator without the air cleaner. Rapid engine wear will result.

1. Open the rear maintenance cover.
2. Unlatch the air cleaner cover spring clips, then remove the air cleaner cover and air cleaner element.
3. Wash the element in a solution of household detergent and warm water, then rinse thoroughly, or wash in nonflammable or high flash point solvent. Allow the element to dry thoroughly.
4. Soak the element in clean engine oil and squeeze out the excess oil. The engine will smoke during initial start-up if too much oil is left in the element.
5. Reinstall the air cleaner element and the cover.
6. Close and latch the rear maintenance cover.

AIR CLEANER COVER

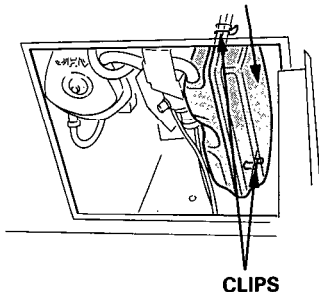

CLIPS

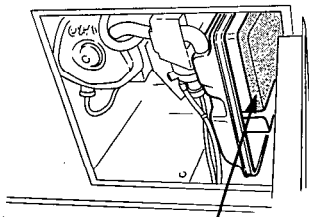

AIR CLEANER ELEMENT

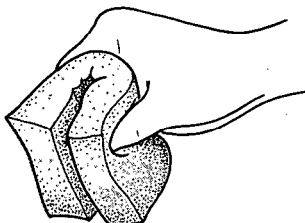

## Spark plug service

**Recommended spark plug: BPR5ES (NGK), W16EPR-U (ND)**

To ensure proper engine operation, the spark plug must be properly gapped and free of deposits.

1. Open the rear maintenance cover.
2. Remove the spark plug cap.
3. Clean any dirt from around the spark plug base.
4. Use the wrench supplied in the tool kit to remove the spark plug.

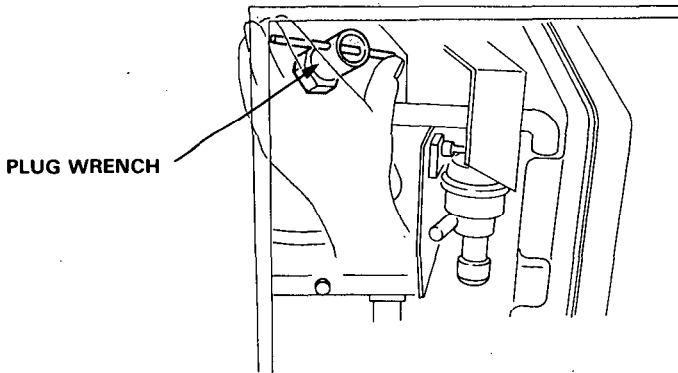

5. Visually inspect the spark plug. Discard it if the insulator is cracked or chipped. Clean the spark plug with a wire brush if it is to be reused.
6. Measure the plug gap with a feeler gauge.  
The gap should be 0.7–0.8 mm (0.028–0.031 in)  
Correct as necessary by carefully bending the side electrode.

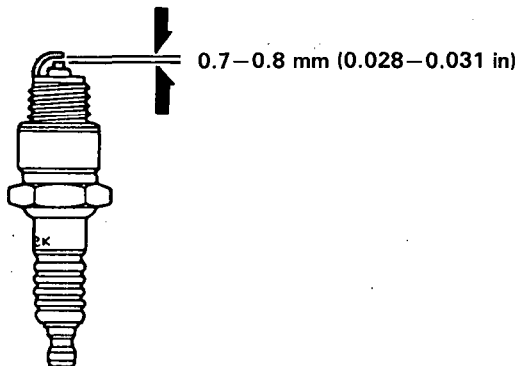

- 
7. Check that the spark plug washer is in good condition, and thread the spark plug in by hand to prevent cross-threading.
  8. After the spark plug is seated, tighten with a spark plug wrench to compress the washer.

**NOTE:** If installing a new spark plug, tighten 1/2 turn after the spark plug seats to compress the washer. If reinstalling a used spark plug, tighten 1/8—1/4 turn after the spark plug seats.

**CAUTION:**

- **The spark plug must be securely tightened. An improperly tightened spark plug can become very hot and could damage the engine.**
- **Never use spark plugs which have an improper heat range. Use only the recommended spark plugs or equivalent.**

9. Close and latch the rear maintenance cover.

---

## Fuel sediment cup cleaning

The sediment cup prevents dirt or water which may be in the fuel tank from entering the carburetor. If the engine has not been run for a long time, the sediment cup should be cleaned.

1. Open the left side maintenance cover.
2. Turn the engine switch to the OFF position. Remove the sediment cup by turning it counterclockwise.
3. Clean the cup and O-ring in nonflammable or high flashpoint solvent.
4. Reinstall the O-ring and sediment cup. Tighten securely.
5. Close and latch the left side maintenance cover.

**▲WARNING** After installing the sediment cup, check for fuel leaks and make sure the area is dry before starting the engine.

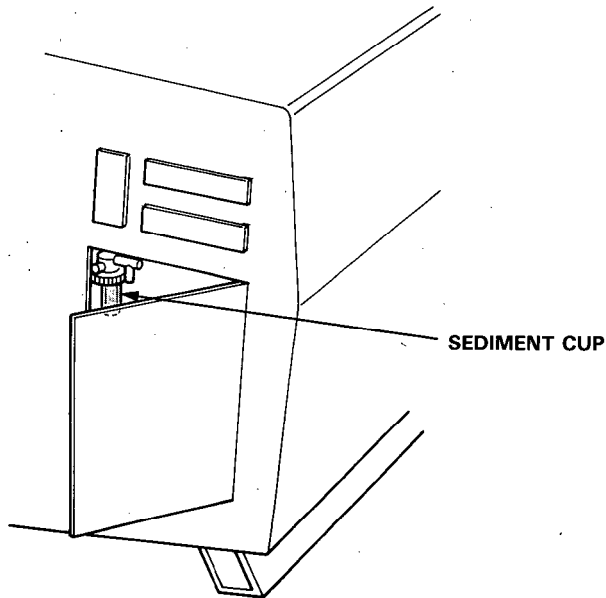

## Spark arrester maintenance

**WARNING** If the generator has been running, the muffler will be very hot. Allow it to cool before proceeding.

**CAUTION:** The spark arrester must be serviced every 100 hours to maintain its efficiency.

1. Remove the nine 6 mm bolts, the handle and right side cover.

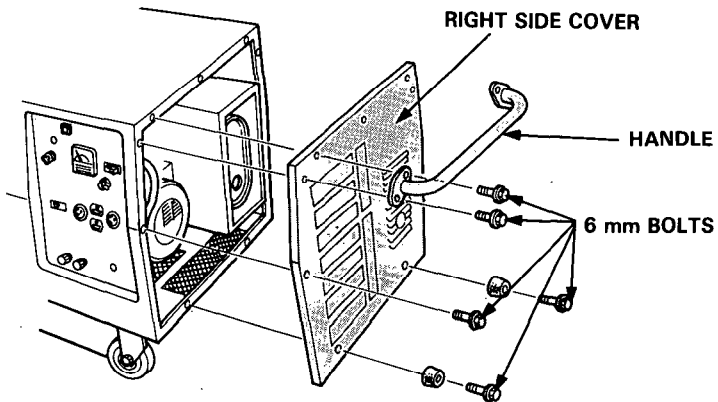

2. Remove the two 5 mm pan screws, and remove the spark arrester.

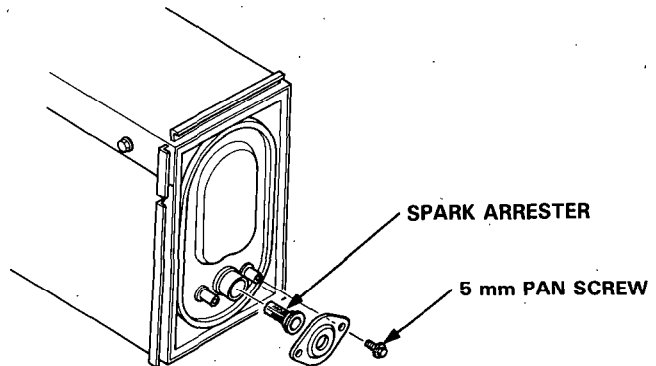

---

3. Use a brush to remove carbon deposits from the spark arrester screen.

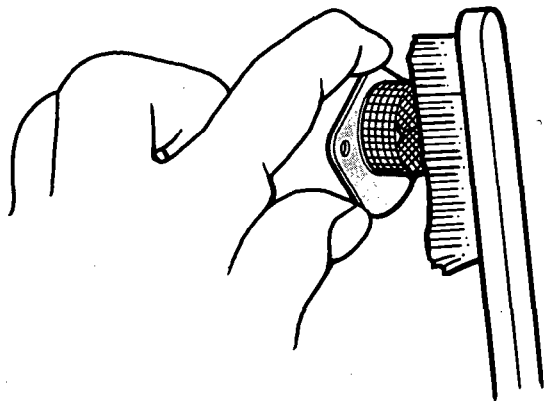

**NOTE:** Inspect the spark arrester screen for holes or tears. Replace if necessary.

4. Reinstall the spark arrester, right side cover and handle.

## Fuse replacement

The fuse holder is located on the battery container.

1. Turn the engine switch to the OFF position.
2. Open the left side maintenance cover, open the fuse holder cover and replace the fuse. The specified fuses are 1A, 5A, 10A.

### CAUTION:

- If frequent fuse failure occurs, determine the cause and correct the problem before attempting to operate the generator further.
- Never use a fuse with a different rating from that specified. Serious damage to the electrical system or fire may result.

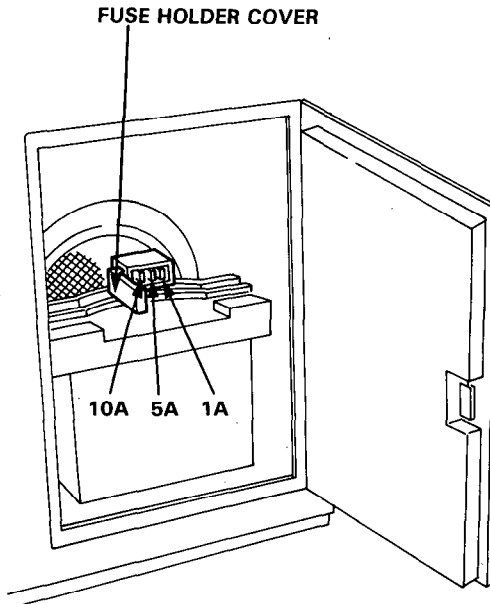

## 8. TRANSPORTING/STORAGE

**▲WARNING** When transporting the generator, turn the engine switch OFF and keep the generator level to prevent fuel spillage. Fuel vapor or spilled fuel may ignite.

Before storing the unit for an extended period:

1. Be sure the storage area is free of excessive humidity and dust.
2. Drain the fuel—

- a. Open the rear maintenance cover.
- b. Turn the engine switch to ON and then loosen the carburetor drain screw. Drain the gasoline from the carburetor and fuel tank into a suitable container.

**▲WARNING** Gasoline is extremely flammable and is explosive under certain conditions. Perform this task in a well ventilated area with the engine stopped. Do not smoke or allow flames or sparks in the area during this procedure.

- c. Tighten the carburetor drain screw, turn the engine switch to OFF and close the rear maintenance cover.
- d. Drain the fuel sediment cup (see page 26).

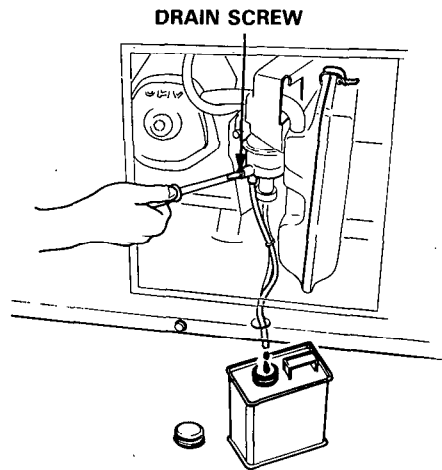

3. Change the engine oil.
4. Remove the spark plug, and pour about a tablespoon of clean engine oil into the cylinder. Crank the engine several revolutions to distribute the oil, then reinstall the spark plug.
5. Cover the generator to keep out dust.
6. Once a month, recharge the battery.

**NOTE:** When starting the generator after adding fuel for the first time, after long-term storage, or after running out of fuel turn the engine switch to the "ON" position, then wait for 10 to 20 seconds before starting the engine.



# 9. TROUBLESHOOTING

When the engine will not start:

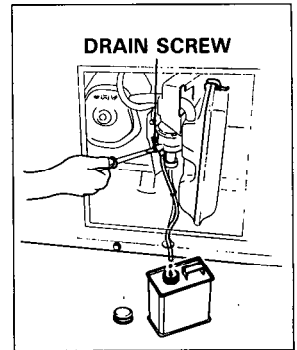
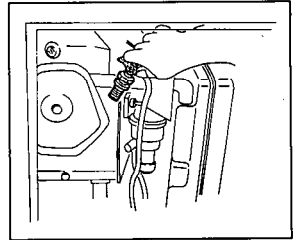
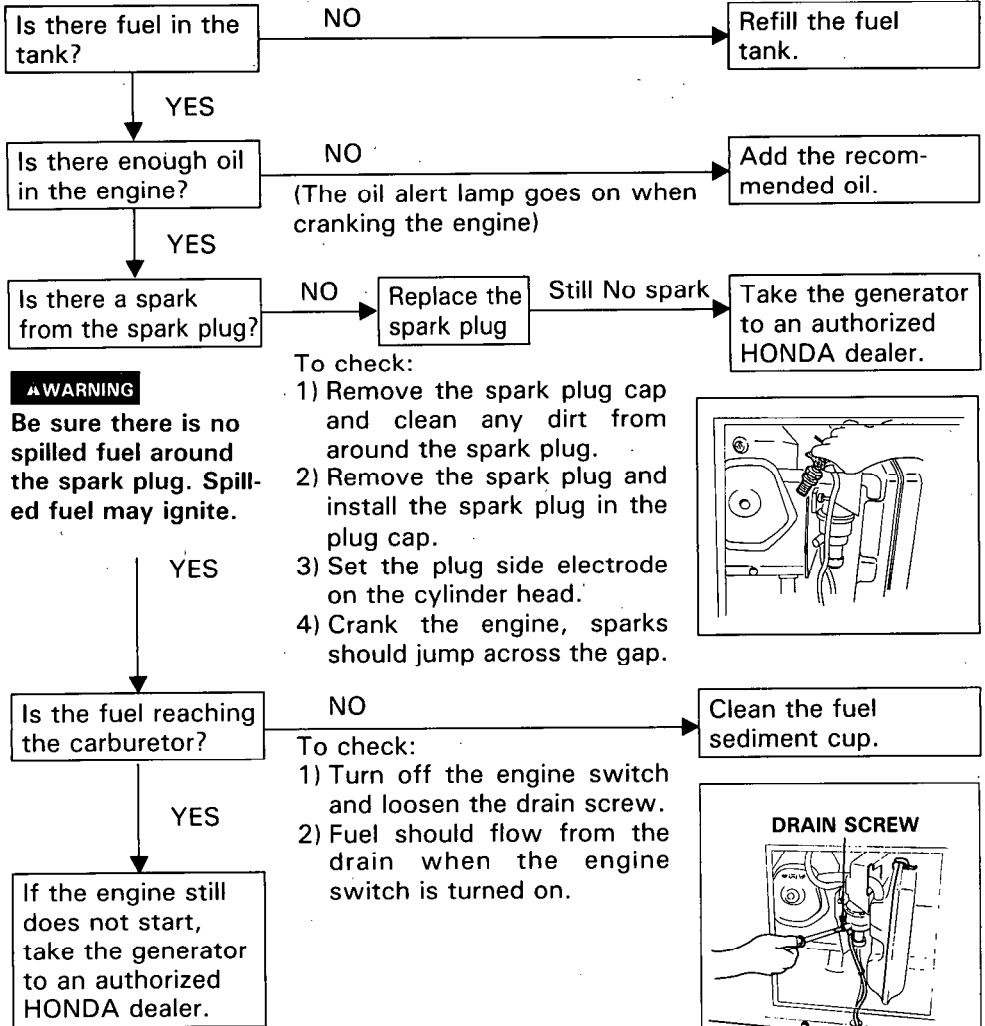

No electricity at the AC receptacles:

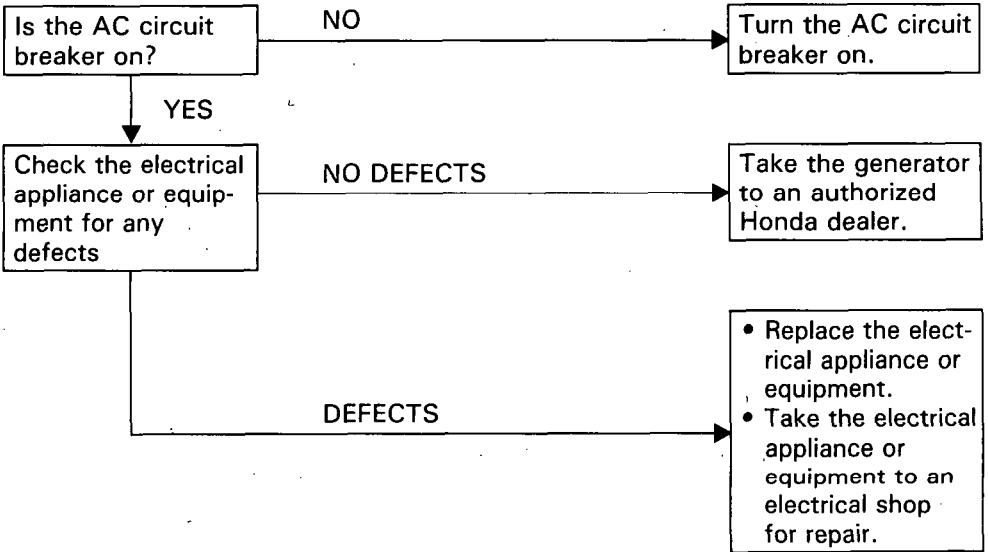

# 10. WIRING DIAGRAM

EX3300S

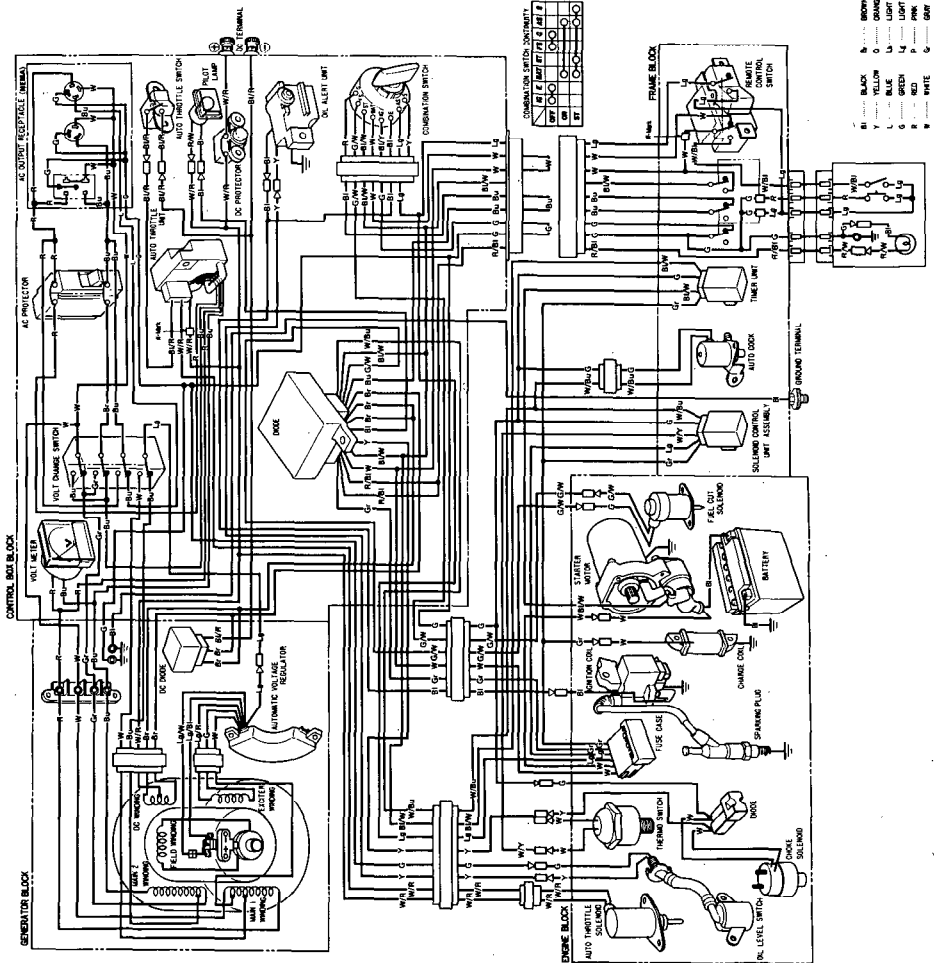

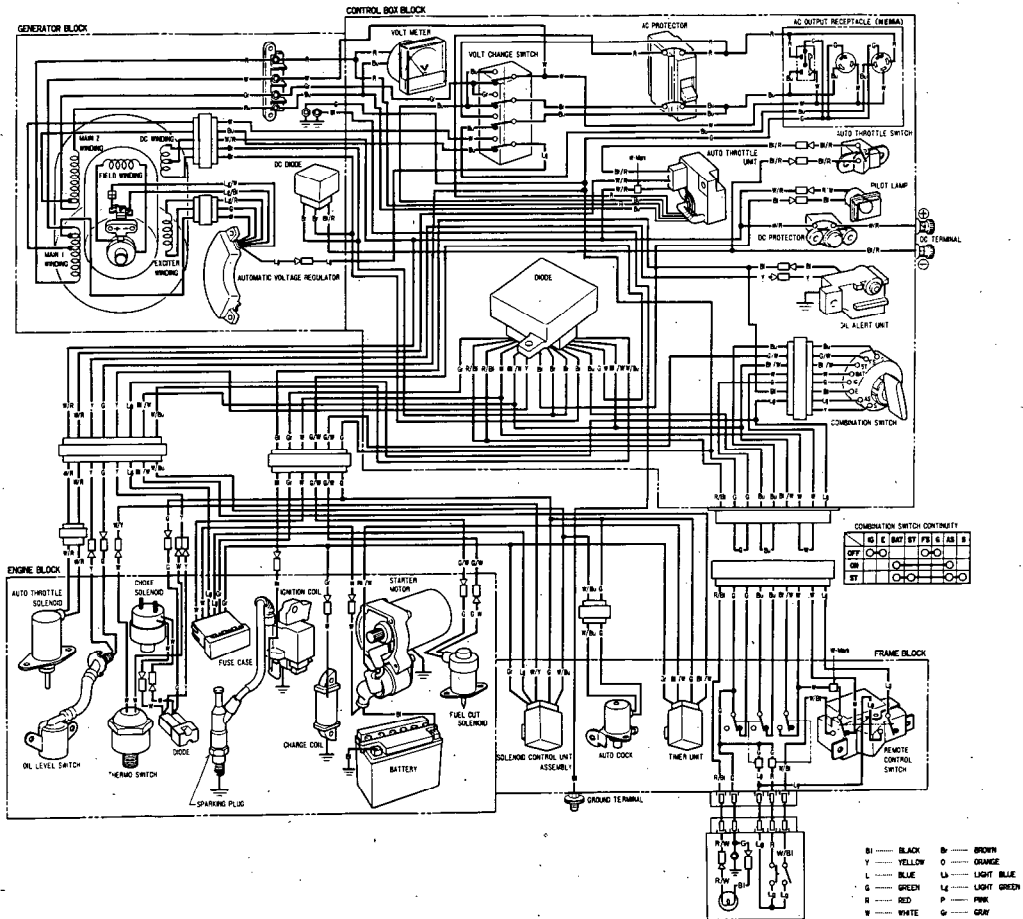

# 11. SPECIFICATIONS

## Dimensions

MODEL	EX3300S	EX4500S
Power product description code	EB2	EB3
Length x Width x Height	910 x 530 x 695 mm (35.8 x 20.9 x 27.4 in)	
Dry weight	109 kg (240.3 lb)	122 kg (268.9 lb)

## Engine

Engine type	GX240	GX340
Displacement [Bore x Stroke]	242 cc (14.8 cu in) [73 x 58 mm (1.9 x 2.3 in)]	337 cc (20.6 cu in) [82 x 64 mm (3.2 x 2.5 in)]
Compression Ratio	8.2 : 1	8.0 : 1
Engine Speed	3600 r.p.m	
Cooling System	Forced air	
Ignition System	Transistorized magneto	
Oil Capacity	1.1 ℓ (1.16 US qt)	
Fuel tank Capacity	19 ℓ (5.02 US gal)	
Spark Plug	BPR5ES (NGK) W16EPR-U (ND)	

## Generator

AC output	Rated Voltage Rated Frequency	120/240V 60Hz	
	Rated Ampere	25/12.5A	33.3/16.7A
	Rated Output	3.0kVA	4.0kVA
	Maximum Output	3.3kVA	4.5kVA
DC output		Only for charging 12V automotive batteries Maximum charging output = 8.3A	

## 12. INSTALLATION OF OPTIONAL PARTS

### Remote Control Kit

(Installation)

1. Remove the panel from the front cover.
2. Disconnect the jumper coupler from the 9-P coupler.
3. Connect the 9-P coupler of the remote control panel to the 9-P coupler disconnected in step 2.
4. Install the remote control panel with four screws.

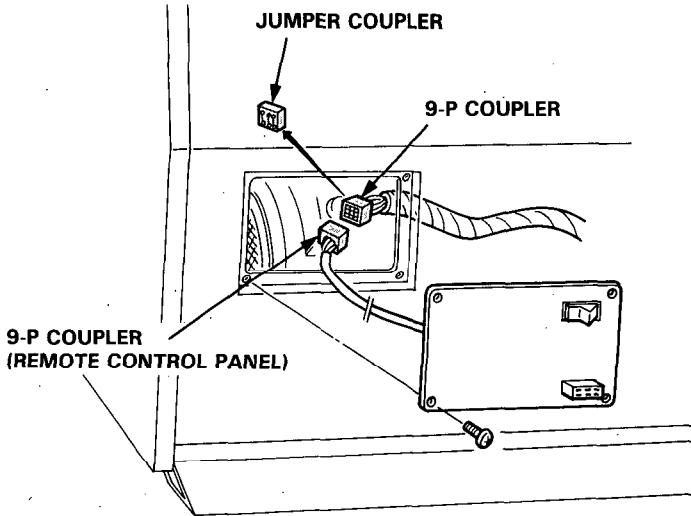

5. Connect the remote control cable coupler to the remote control panel coupler.

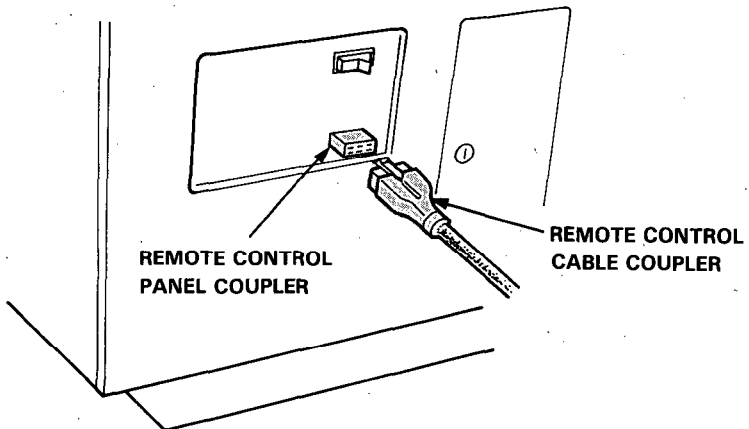

## STARTING WITH REMOTE CONTROL

1. Make sure the engine switch is OFF.
2. Turn the auto throttle switch to OFF.
3. Remove the ignition switch key from the generator.
4. Turn the remote control switch to ON.
5. Flip the remote control engine switch knob up to ON.
6. Depress the starter button until the pilot lamp comes on.

NOTE: Turn the remote control switch to the OFF position if you wish to start the generator by using the engine switch on the generator control panel.

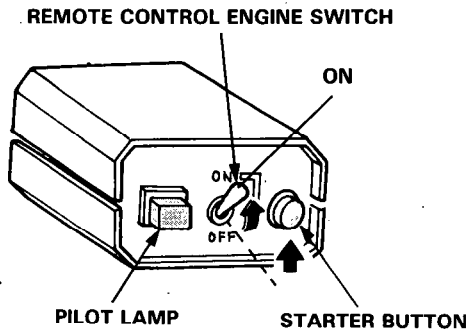
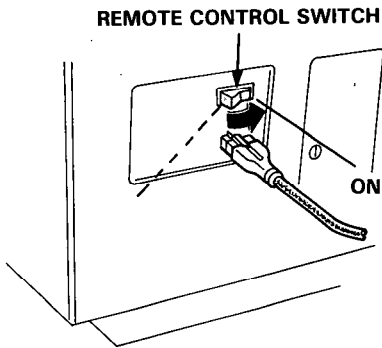

7. To stop the engine, flip the remote control engine switch to the OFF position.

## 13. WARRANTY SERVICE

---

### Owner Satisfaction

Your satisfaction and goodwill are important to your dealer and to us. All Honda warranty details are explained in the Distributor's Limited Warranty. Normally, any problems concerning the product will be handled by your dealer's service department. If you have a warranty problem that has not been handled to your satisfaction, we suggest you take the following action:

- Discuss your problem with a member of dealership management. Often complaints can be quickly resolved at that level. If the problem has already been reviewed with the Service Manager, contact the owner of the dealership or the General Manager.
- If your problem still has not been resolved to your satisfaction, contact the Power Equipment Customer Relations Department of American Honda Motor Co., Inc.

American Honda Motor Co., Inc.  
Power Equipment Customer Relations Department  
P.O. Box 50  
Gardena, California 90247-0805  
Telephone: (213) 604-2400

We will need the following information in order to assist you:

- Your name, address, and telephone number
- Product model and serial number
- Date of purchase
- Dealer name and address
- Nature of the problem

After reviewing all the facts involved, you will be advised of what action can be taken. Please bear in mind that your problem will likely be resolved at the dealership, using the dealer's facilities, equipment, and personnel, so it is very important that your initial contact be with the dealer.

Your purchase of a Honda product is greatly appreciated by both your dealer and American Honda Motor Co., Inc. We want to assist you in every way possible to assure your complete satisfaction with your purchase.



---

**MEMO**

---

**MEMO**

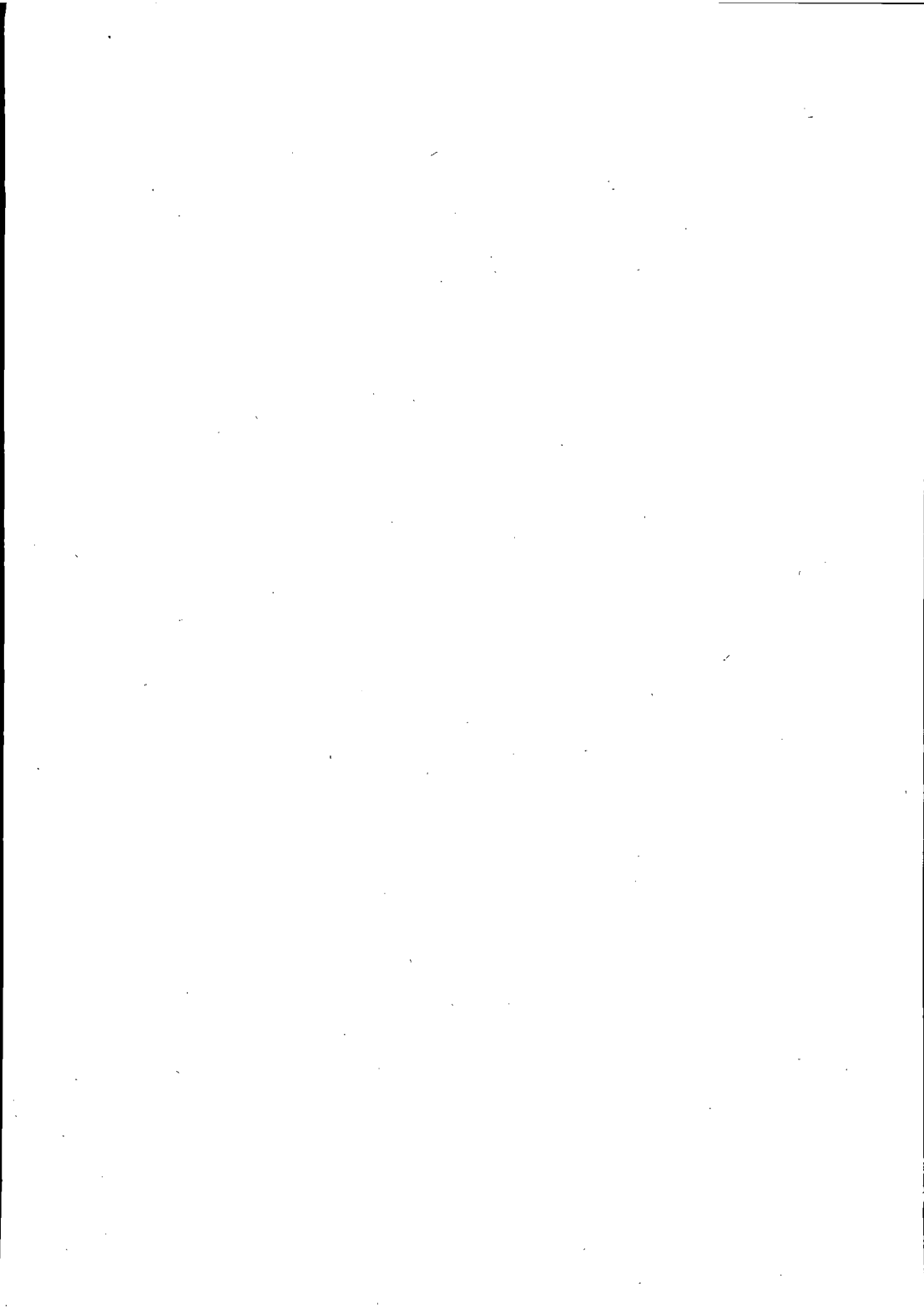

**HONDA**  
HONDA MOTOR CO., LTD. TOKYO, JAPAN

31ZB7603  
00X31-ZB7-6031

AM 10009010  
PRINTED IN JAPAN