

HONDA

Power

Equipment

Owner's Manual

EM3000•EM4000



Thank you for purchasing a Honda generator.

This manual covers operation and maintenance of the EM 3000 and EM4000 generators. All information in this publication is based on the latest product information available at the time of approval for printing.

Honda Motor Co., Ltd. reserves the right to make changes at any time without notice and without incurring any obligation.

No part of this publication may be reproduced without written permission.

This manual should be considered a permanent part of the generator and remain with the generator when sold.

Pay special attention to statements preceded by the following words:

WARNING Indicates a strong possibility of severe personal injury or loss of life if instructions are not followed.

CAUTION: Indicates a possibility of personal injury or equipment damage if instructions are not followed.

NOTE: Gives helpful information.

If a problem should arise, or if you have any questions about the generator, consult an authorized Honda dealer.

WARNING The Honda generator is designed to give safe and dependable service if operated according to instructions. Read and understand the Owner's Manual before operating the generator. Failure to do so could result in personal injury or equipment damage.

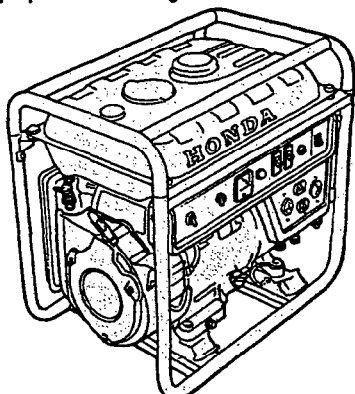

CONTENTS

CONTENTS

1. GENERATOR SAFETY	1
2. COMPONENT IDENTIFICATION	2
3. PRE-OPERATION CHECK	4
4. STARTING THE ENGINE	8
5. GENERATOR USE	11
6. STOPPING THE ENGINE	14
7. MAINTENANCE	16
8. TRANSPORTING/STORAGE	25
9. TROUBLESHOOTING	27
10. SPECIFICATIONS	30
11. WIRING DIAGRAM	31

1. GENERATOR SAFETY

WARNING

To ensure safe operation –

- Place the generator at least 1 m (3 ft) away from buildings or other equipment when operating the generator.
- Operate the generator on a level surface.
If the generator is tilted, fuel spillage may result.
- Exhaust gas contains poisonous carbon monoxide.
Never run the generator in an enclosed area.
Be sure to provide adequate ventilation.
- Know how to stop the generator quickly and understand operation of all the controls. Never permit anyone to operate the generator without proper instructions.
- Keep children and pets away from the generator when it is in operation.
- Keep away from rotating parts while the generator is running.
- The generator is a potential source of electrical shocks when misused; do not operate with wet hands.
Do not operate the generator in rain or snow and do not let it get wet.

2. COMPONENT IDENTIFICATION

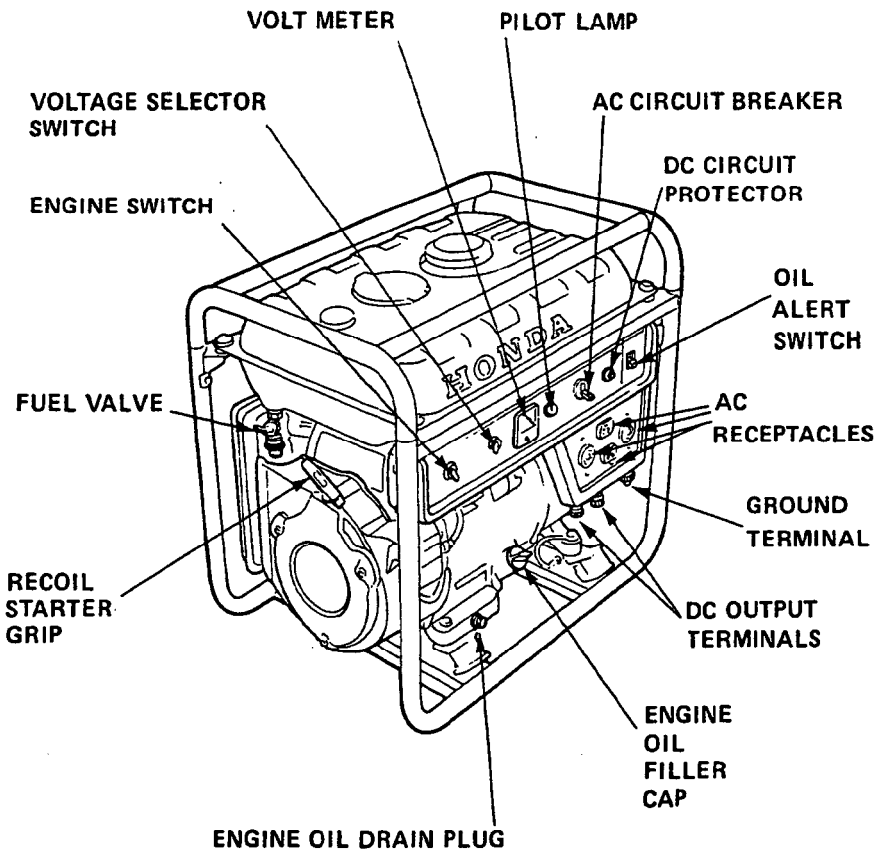

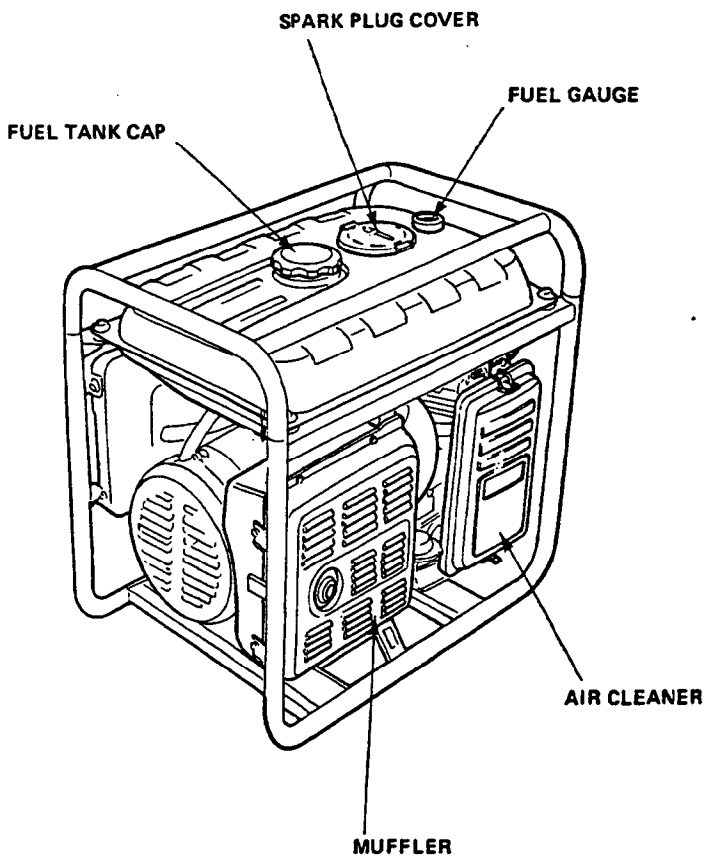

3. PRE-OPERATION CHECK

CAUTION: Be sure to check the generator on a level surface with the engine stopped.

1. Check the engine oil level.

CAUTION: Engine oil is a major factor affecting engine performance and service life. Non-detergent or vegetable oils are not recommended.

Use Honda 4-stroke oil, or an equivalent high detergent, premium quality motor oil certified to meet or exceed U.S. automobile manufacturer's requirements for Service Classification SE or SF. (Motor oils classified SE or SF will show this designation on the container.)

SAE 10W-40 is recommended for general, all-temperature use.

Remove the oil filler cap and check the oil level.

If the level is low, fill to the top of the oil filler neck with the recommended oil.

CAUTION: Running the engine with insufficient oil can cause serious engine damage.

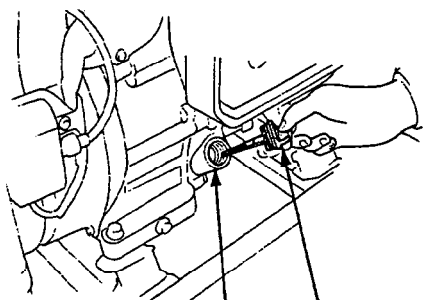

FILLER HOLE

OIL FILLER CAP

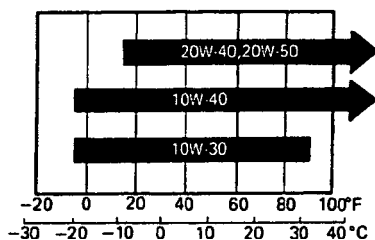

NOTE: When the oil runs lower than the specified level during operation, the oil alert switch automatically turns off to protect the engine from overheating.

If this occurs, add oil to the top of the filler hole neck, then turn the switch on and restart the engine according to the instructions.

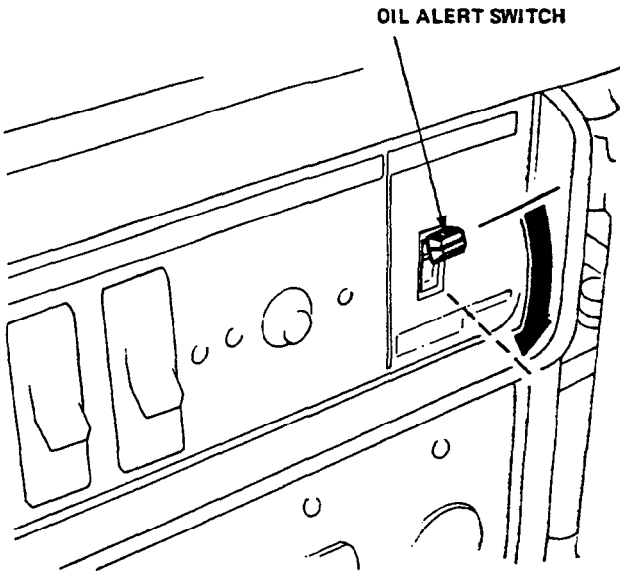

2. Check the fuel level.

Use any regular grade automotive gasoline (unleaded gasoline is preferred) with a pump octane rating of 86 or higher.

Never use an oil/gasoline mixture or dirty gasoline. Avoid getting dirt, dust or water in the fuel tank.

CAUTION: Gasoline substitutes are not recommended; they may be harmful to the fuel system components.

WARNING

- Gasoline is extremely flammable and explosive under certain conditions. Refuel in a well ventilated area with the engine stopped.
- Do not smoke or allow flames or sparks in the area where the generator is refueled or where gasoline is stored.
- Do not overfill the tank and make sure the filler cap is securely closed after refueling.
- Be careful not to spill fuel when refueling. Fuel vapor or spilled fuel may ignite. If any fuel is spilled, make sure the area is dry before starting the engine.

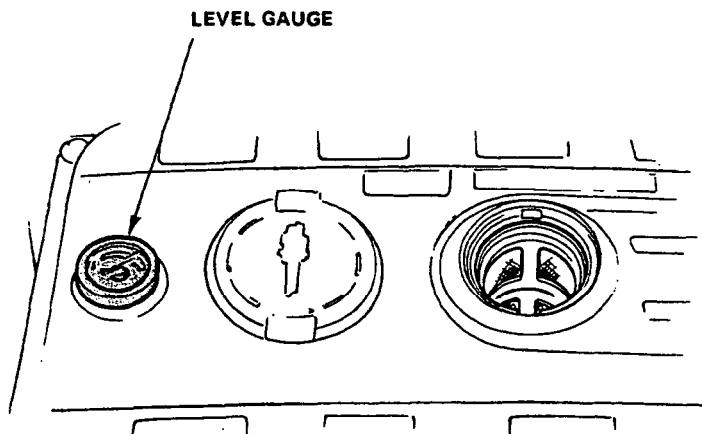

-
3. Make sure that the AC circuit breaker is OFF and that nothing is connected to the DC terminals.
The generator may be hard to start if a load is connected.

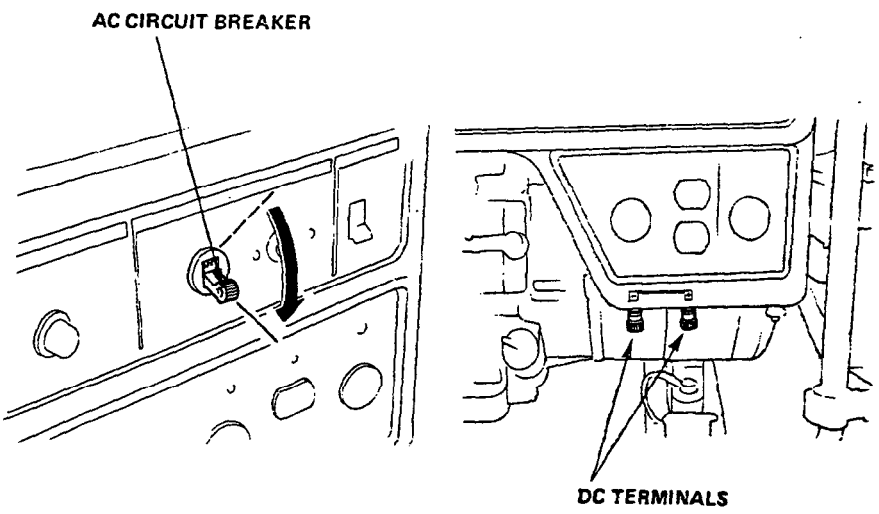

4. STARTING THE ENGINE

1. Turn the fuel valve on.

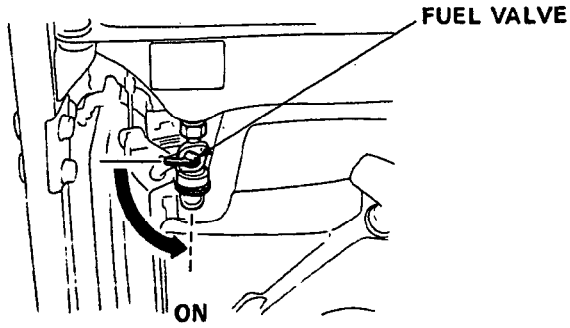

2. Pull the choke rod to CLOSE.

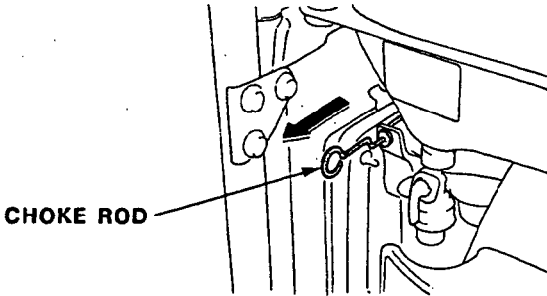

3. Turn the oil alert switch on.

OIL ALERT SWITCH

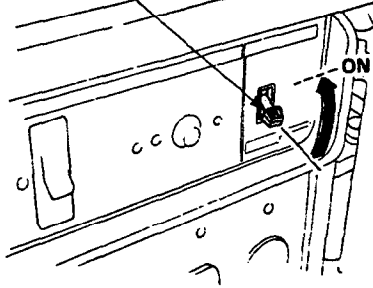

4. Turn the engine switch on.

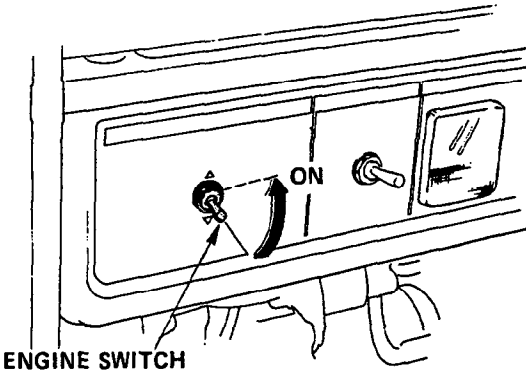

5. Pull the starter grip until compression is felt, then pull briskly.

NOTE: Do not allow the starter grip to snap back. Return it slowly by hand.

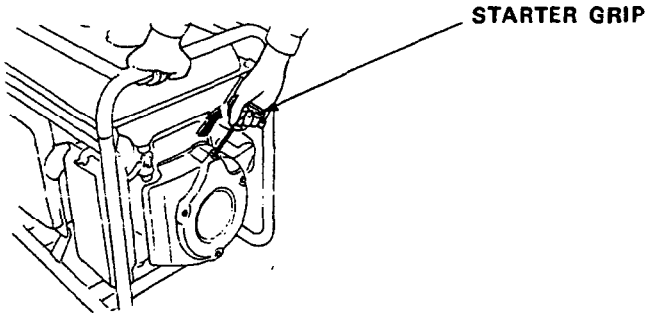

6. Push the choke rod to OPEN as the engine warms up.

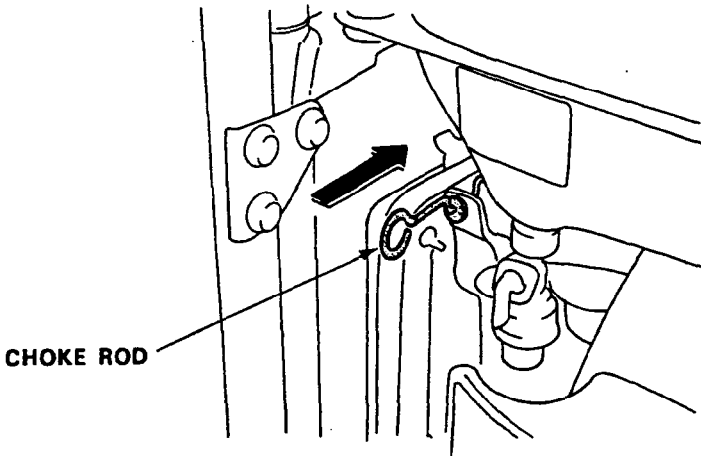

5. GENERATOR USE

WARNING To prevent electrical shock from faulty appliances, the generator should be grounded. Connect a length of heavy wire between the ground terminal and the ground source.

CAUTION:

- Limit operation requiring maximum power (EM3000: 3.0kVA, EM4000: 4.0kVA) to 30 minutes.
For continuous operation, do not exceed the rated power of 2.8 kVA (EM3000) and 3.8 kVA (EM4000).
In either case, the total wattage of all appliances connected must be considered.
- Do not exceed the current limit specified for any one receptacle.
- Connections for emergency power to household circuits must be made by a qualified electrician and must comply with all applicable laws and electrical codes. Improper installation may result in personal injury or damage to equipment or property.

AC applications

1. Start the engine and make sure the pilot lamp comes on. If not, the filament may be burnt out.
2. Turn the voltage selector switch to either position as required. When the switch is turned to "120V ONLY" position, you can use only 120V AC. At "120V/240V" position, you can use both 120V and 240V sources.
3. Switch on the AC Circuit Breaker.
4. Plug in the appliance.

CAUTION: Be sure that appliances do not exceed the rated load for more than 30 minutes, and never exceed the maximum load. Substantial overloading will switch off the circuit breaker. Lesser overloading will not switch off the circuit breaker and will shorten the service life of the generator.

NOTE: This generator is equipped with an AVR (Automatic Voltage Regulator) for stable voltage supply.

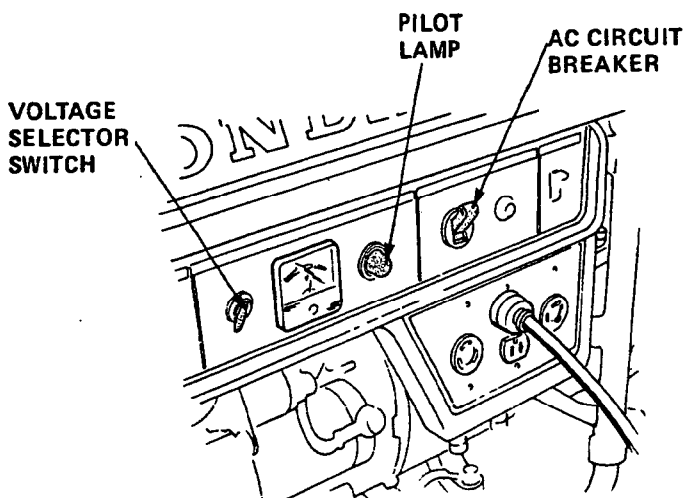

DC application

The DC terminals may be used for charging 12 volt automotive-type batteries only.

WARNING Batteries produce explosive gases. Keep sparks, flames, and cigarettes away. To prevent the possibility of creating a spark near the battery, connect charging cables first to the battery, then to the generator, and disconnect cables first at the generator.

CAUTION:

- Do not attempt to start an automobile engine with the generator still connected to the battery. The generator may be damaged.
- Connect the positive battery terminal to the positive generator terminal. Do not reverse the charging cables, or serious damage to the generator and/or battery may occur.

NOTE:

- The DC terminals may be used while the AC power is in use.
- An overloaded DC circuit will trip the DC circuit protector (push button comes out). If this happens, wait a few minutes before pushing the circuit protector to resume operation.

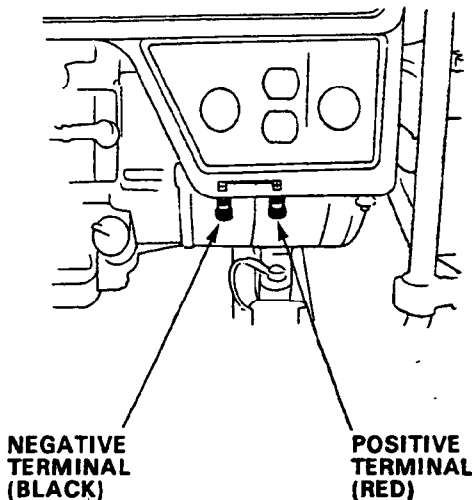

6. STOPPING THE ENGINE

To stop the engine in an emergency, turn the engine switch OFF.

In normal use:

1. Turn the AC circuit breakers OFF and or disconnect the charging leads at the DC terminals.

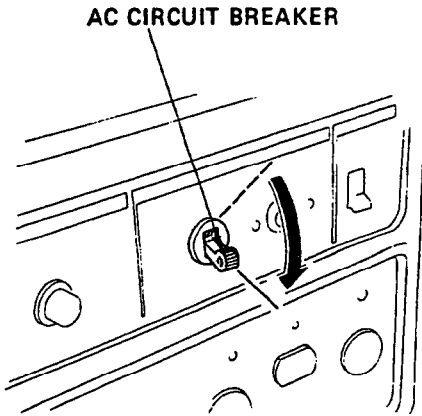

2. Turn the engine switch OFF.

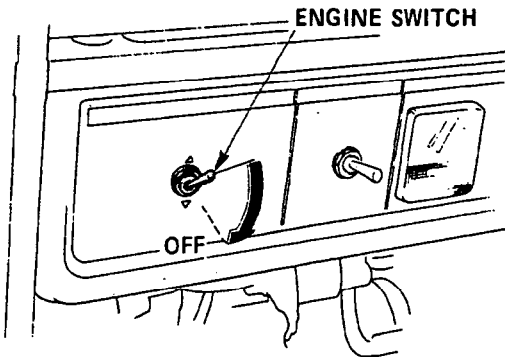

3. Turn the fuel valve OFF.

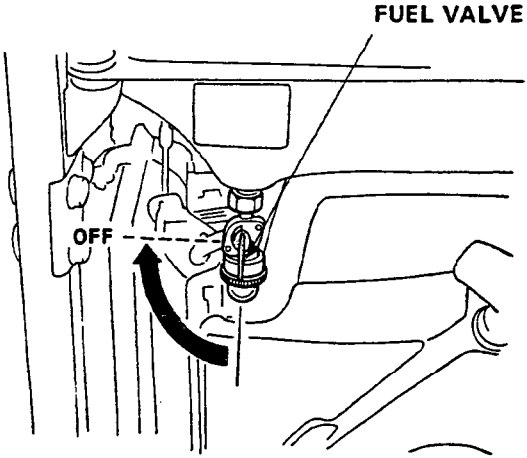

7. MAINTENANCE

The purpose of the maintenance schedule and adjustment is to keep the generator in the best operating condition.

Inspect or service as scheduled in the table on the next page.

 **WARNING** Shut off the engine before performing any maintenance. If the engine must be run, make sure the area is well ventilated. The exhaust contains poisonous carbon monoxide gas.

CAUTION: Use only genuine HONDA parts or their equivalent. The use of replacement parts which are not of equivalent quality may damage the generator.

Maintenance Schedule

REGULAR SERVICE PERIOD Perform at every indicated month or operating hour interval, whichever occurs first.		Daily	First month or 20 Hrs.	Every 3 months or 50 Hrs.	Every 6 months or 100 Hrs.	Every year or 300 Hrs.
ITEM						
Engine oil	Inspection	●				
	Change		●		●	
Air cleaner element	Inspection	●				
	Cleaning			● (1)		
Fuel filter cleaning					●	
Spark plug maintenance					●	
Valve clearance adjustment						● (2)
Combustion chamber and valve cleaning						● (2)
Fuel line inspection (Replace if necessary)						●
Spark arrester		Clean every 100 operating hours.				

NOTE (1) : Service more frequently when used in dusty areas.

(2) : These items should be serviced by an authorized Honda dealer, unless the owner has the proper tools and is mechanically proficient. See the Honda Shop Manual.

Tool kit

The tools supplied are necessary for performing some periodic maintenance, simple adjustments and repairs.

Always keep the kit with the generator.

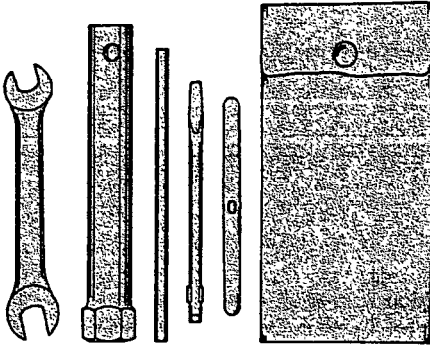

Changing oil

Drain the oil while the engine is still warm to assure rapid and complete draining.

1. Remove the drain plug and filler cap, and drain the oil. Retighten the plug securely.
2. Refill with the recommended oil (see page 4) and check the level.

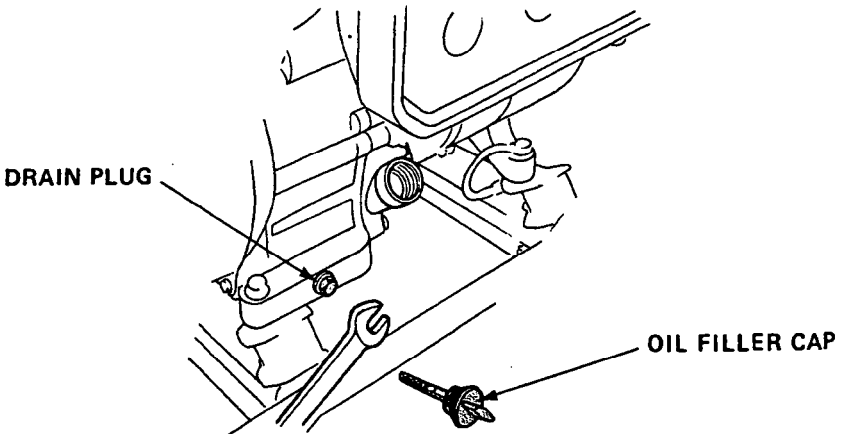

Air cleaner service

A dirty air cleaner will restrict air flow to the carburetor. To prevent carburetor malfunction, service the air cleaner regularly (page 20). Service more frequently when operating the generator in extremely dusty areas.

WARNING Never use gasoline or low flash point solvents for cleaning the air cleaner element. A fire or explosion could result.

CAUTION: Never run the generator without the air cleaner. Rapid engine wear may result.

1. Unsnap the clips, remove the air cleaner cover and remove the element.

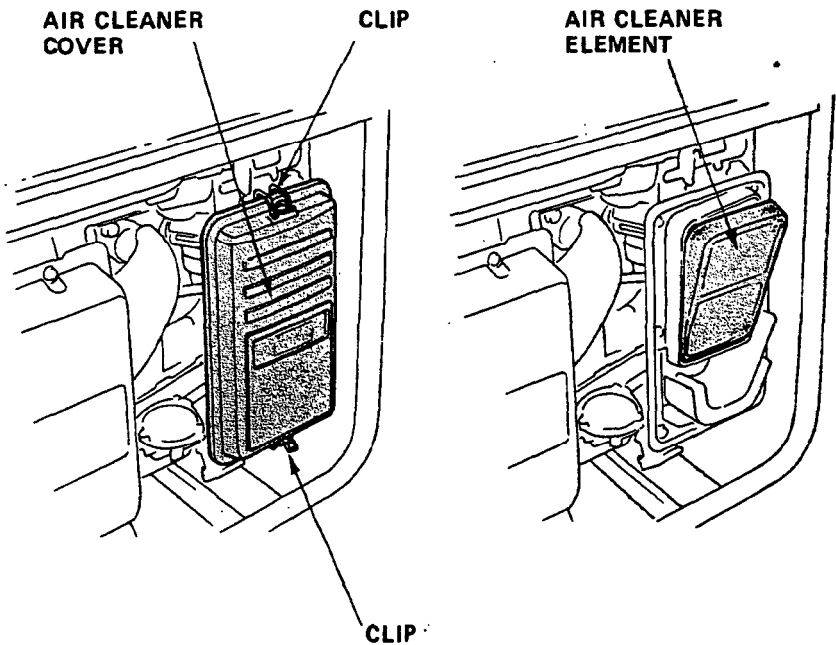

-
2. Wash the element in a non-flammable or high flash point solvent and dry it thoroughly.
 3. Soak the element in clean engine oil and squeeze out the excess oil.
 4. Reinstall the air cleaner element and the cover.

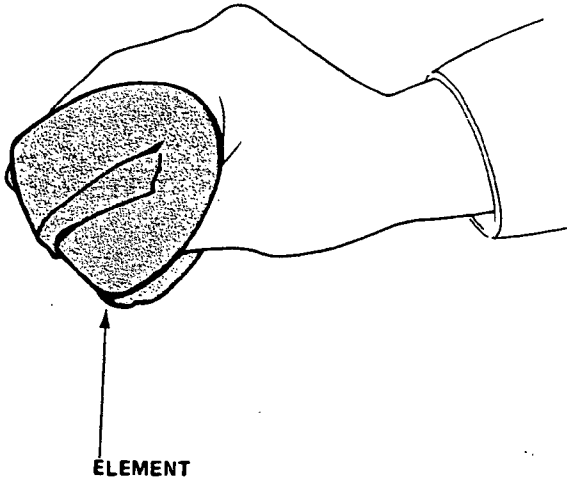

Fuel filter service

The filter prevents dirt or water which may be in the fuel tank from entering the carburetor. If the engine has not been run for a long time, the filter should be cleaned.

1. Turn the fuel valve OFF. Remove the filter cup.
2. Clean the cup thoroughly.
3. Reassemble. Do not damage the rubber gasket.

WARNING After installing the filter cup, check for fuel leaks and make sure the area is dry before starting the engine.

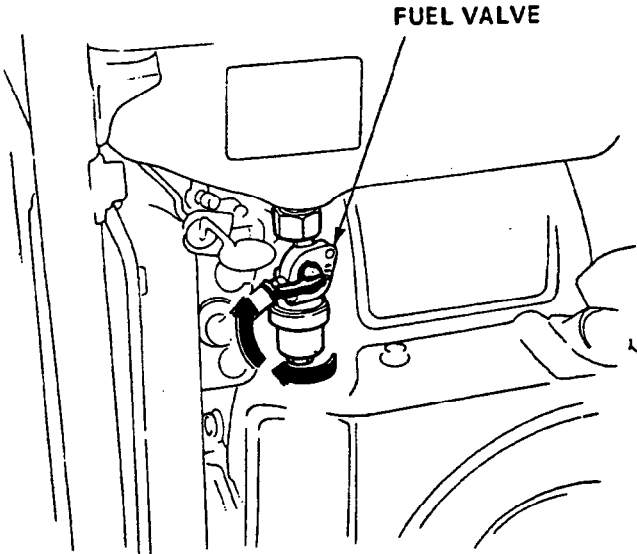

Spark plug service

Recommended spark plug: BPR4HS-10 (NGK)
W14FPR-UL10 (ND)

To ensure proper engine operation, the spark plug must be properly gapped and free of deposits.

1. Remove the spark plug cover.
2. Clean any dirt from around the spark plug base.
3. Remove the spark plug cap.

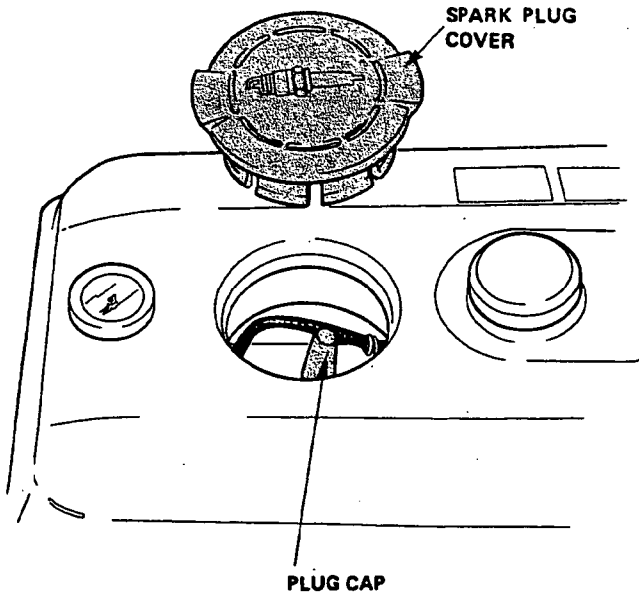

-
4. Use the wrench supplied in the tool kit to remove the spark plug.
 5. Visually inspect the spark plug. Discard it if the insulator is cracked or chipped.
 6. Measure the plug gap with a feeler gauge.
The gap should be 0.9–1.0 mm (0.035–0.039 in). Correct as necessary by bending the side electrode.
 7. Attach the plug washer. Thread the plug in by hand to prevent cross-threading.
 8. Tighten a new spark plug 1/2 turn with the wrench to compress the washer. If you are reusing a plug, it should only take 1/8–1/4 turn after the plug seats.

CAUTION:

- The spark plug must be securely tightened. An improperly tightened plug can become very hot and possibly damage the generator.
- Never use a spark plug with an improper heat range.

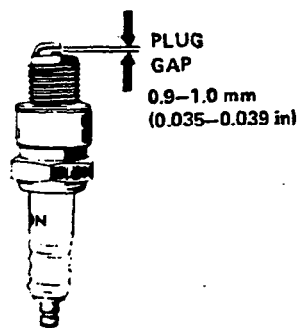
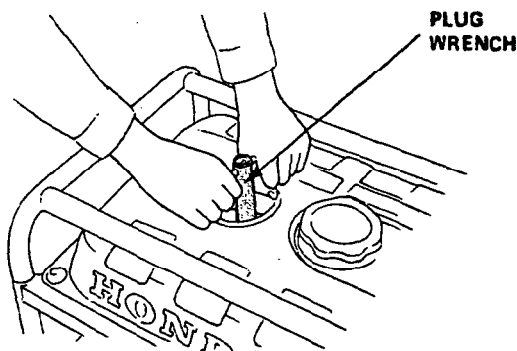

Spark arrester maintenance

WARNING If the generator has been running, the muffler will be very hot. Allow it to cool before proceeding.

CAUTION: The spark arrester must be serviced every 100 hours to maintain its efficiency.

1. Loosen the bolts and nuts and remove the muffler.
2. Loosen two 8mm bolts to remove the exhaust pipe.
3. Check the muffler exhaust port for carbon deposits; clean if necessary.
4. Remove the spark arrester from the muffler.
Clean the screen and inspect it for damage. Replace if necessary.
5. Install the spark arrester in the muffler.
Install the muffler and gasket and tighten the bolts and nuts securely.

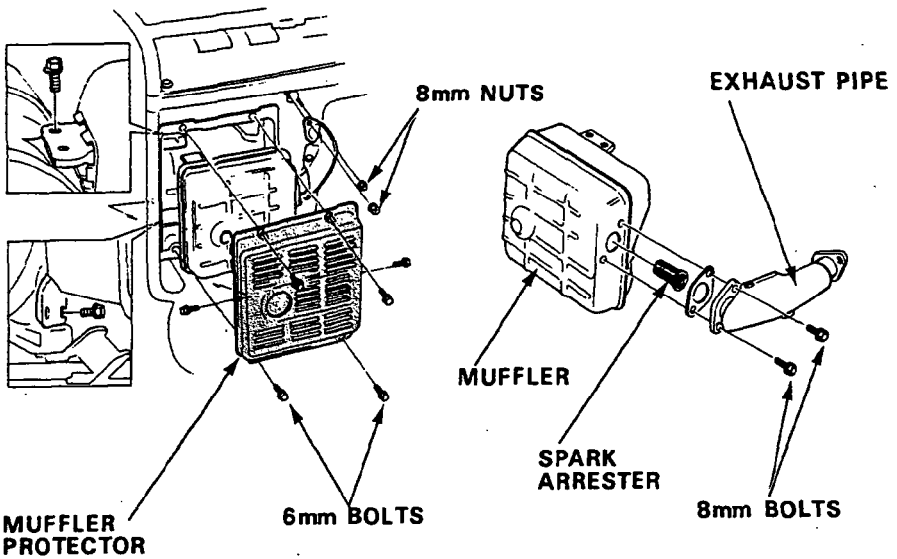

8. TRANSPORTING/STORAGE

WARNING When transporting the generator, turn the engine switch OFF and keep the generator level to prevent fuel spillage. Fuel vapor or spilled fuel may ignite.

Before storing the unit for an extended period:

1. Be sure the storage area is free of excessive humidity and dust.
2. Drain the fuel –
 - a. With the fuel valve OFF, remove and empty the filter cup.
 - b. Turn the fuel valve ON and drain the gasoline in the fuel tank into a suitable container.
 - c. Replace the filter cup and tighten securely.

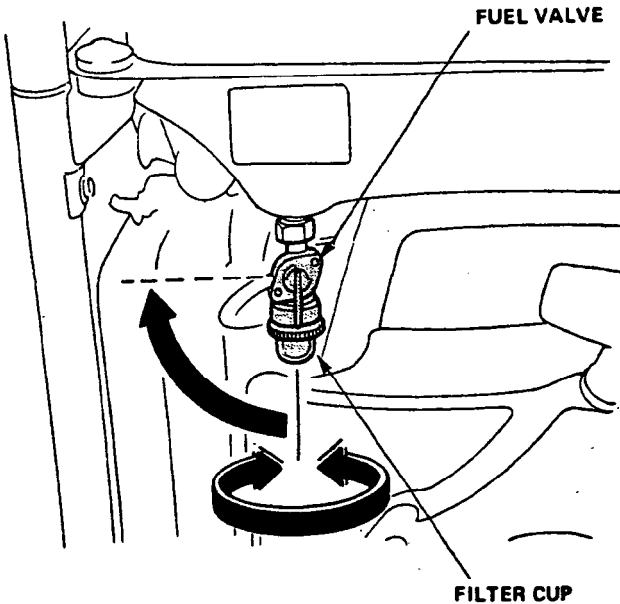

-
- d. Drain the carburetor by loosening the drain screw. Drain the gasoline into a suitable container.

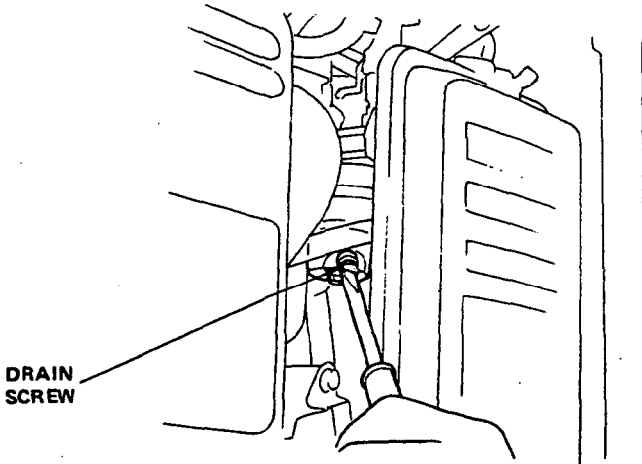

- e. Pull the starter grip until resistance is felt; the piston is coming up on its compression stroke. At this position, the exhaust and intake valves are closed, and this will help protect the engine from corrosion.

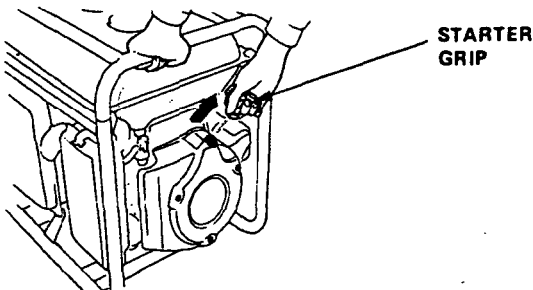

9. TROUBLESHOOTING

A. When the engine will not start:

1. Is there enough fuel?
2. Is the fuel valve on?
3. Is gasoline reaching the carburetor?

To check, loosen the drain screw with the fuel valve on.

⚠ WARNING If any fuel is spilled, make sure the area is dry before testing the spark plug or starting the engine. Fuel vapor or spilled fuel may ignite.

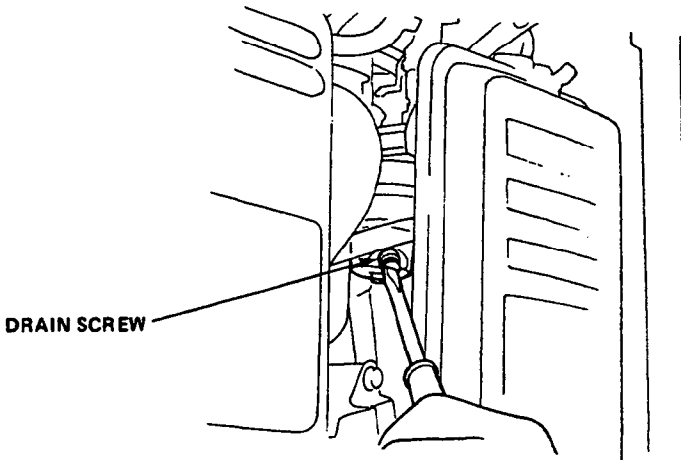

4. Is there enough oil in the crankcase? Is the oil alert switch on?
5. Is the AC circuit breaker off and nothing connected to the DC terminals?
6. Is the engine switch on?
7. Is there a spark at the spark plug (page 22)?

-
- a. Remove the spark plug cover and cap. Clean any dirt from around the spark plug base, then remove the spark plug.
 - b. Install the spark plug in the plug cap.
 - c. Turn the engine switch on.
 - d. Turn the oil alert switch on.
 - e. Grounding the side electrode to the stay, pull the recoil starter to see if sparks jump across the gap.

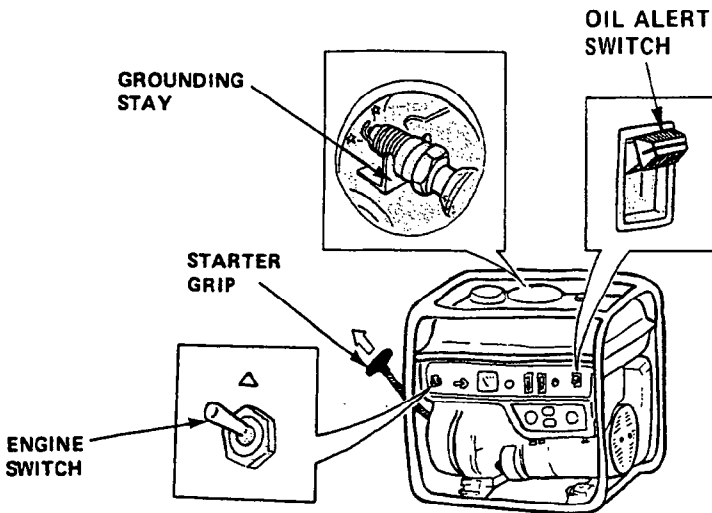

- f. If there are no sparks, replace the plug.
If OK, try to start the engine according to the instructions.
8. If the engine still does not start, take the generator to the dealer.

-
- B. When the engine starts but stops immediately:**
Is there enough oil in the crankcase?
If not, the oil alert switch will turn off after starting.
- C. No electricity at the AC receptacles:**
1. Are the AC circuit breakers on?
 2. Check the electrical appliance or equipment for any defects.
- D. No electricity at the DC terminals:**
1. Is the DC circuit protector on?
 2. Check the electrical appliance or equipment for any defects.

10. SPECIFICATIONS

Dimensions

Length x Width x Height	EM3000: 605 x 425 x 545mm (23.8 x 16.7 x 21.5 in) EM4000: 650 x 425 x 575mm (25.6 x 16.7 x 22.6 in)
Dry weight	EM3000: 64.0kg (141.1 lb) EM4000: 81.0kg (178.6 lb)

Engine

Model	Honda GE300	Honda GE400
Engine Type	4-stroke, side valve, 1 cylinder	
Displacement [Bore x Stroke]	272cm ³ (16.6 cu in) [76x60mm (3.0x2.4 in)]	406cm ³ (24.8 cu in) [86x70mm (3.4x2.8 in)]
Compression Ratio	6.5 : 1	6.8 : 1
Engine Speed	3,600 rpm	
Cooling System	Forced air cooling	
Ignition System	C.D.I.	
Oil Capacity	1.2ℓ (1.27 US qt)	
Fuel Tank Capacity	16.5ℓ (4.4 US gal)	
Spark Plug	BPR4HS-10 (NGK) W14FPR-UL10 (ND)	

Generator

AC output	Rated voltage	120V/240V
	Rated frequency	60Hz
	Rated ampere	EM3000: 23.5/12A EM4000: 32/16A
	Rated output	EM3000: 2.8kVA (2800W) EM4000: 3.8kVA (3800W)
	Maximum output	EM3000: 3.0kVA (3000W) EM4000: 4.0kVA (4000W)
DC output	Only for charging 12V automotive batteries. Maximum charging output = 8.3A	

11. WIRING DIAGRAM

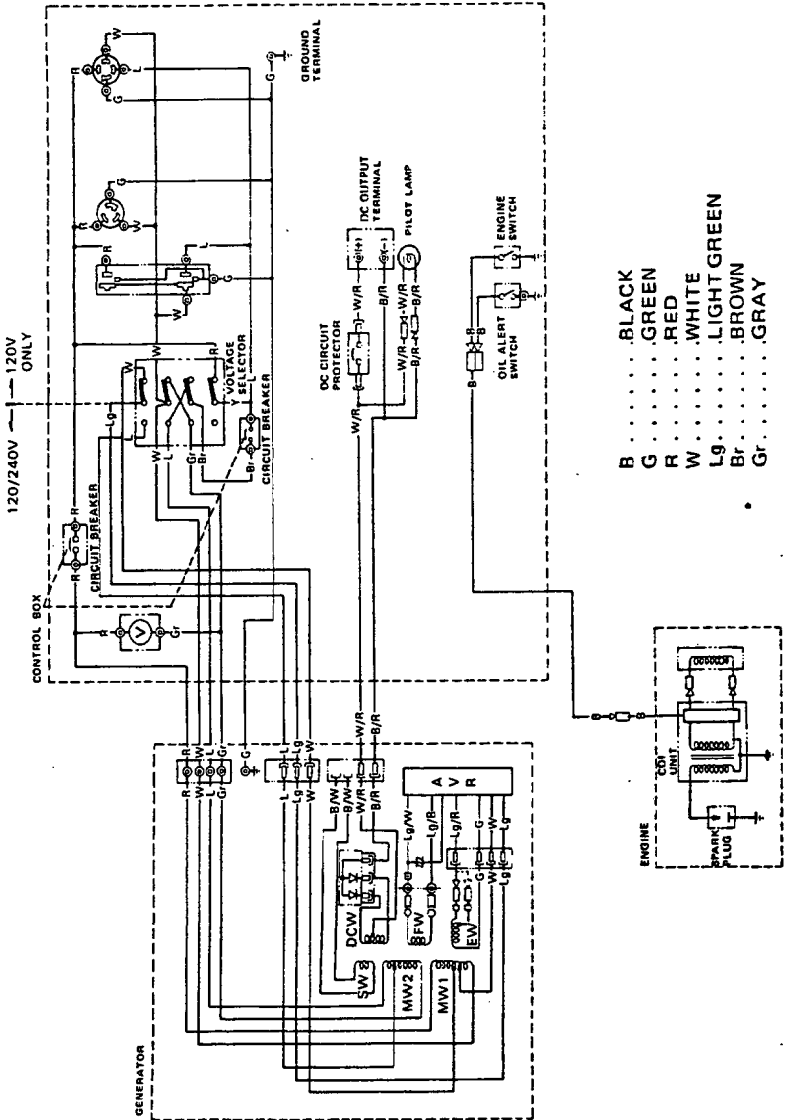

Warranty Service

Owner Satisfaction

Your satisfaction and goodwill are important to your dealer and to us. All Honda warranty details are explained in the Distributor's Limited Warranty. Normally, any problems concerning the product will be handled by your dealer's service department. If you have a warranty problem that has not been handled to your satisfaction, we suggest you take the following action:

- Discuss your problem with a member of dealership management. Often complaints can be quickly resolved at that level. If the problem has already been reviewed with the Service Manager, contact the owner of the dealership or the General Manager.
- If your problem still has not been resolved to your satisfaction, contact the Customer Relations Department at the regional office of American Honda Motor Co., Inc. in your area. Regional office locations are shown on the following page. We will need the following information in order to assist you:
 - Your name, address, and telephone number
 - Engine model and serial number
 - Date of purchase
 - Dealer name and address
 - Nature of the problem

After reviewing all the facts involved, you will be advised of what action can be taken. Please bear in mind that your problem will likely be resolved at the dealership, using the dealer's facilities, equipment, and personnel, so it is very important that your initial contact be with the dealer.

Your purchase of a Honda engine is greatly appreciated by both the dealer and American Honda Motor Co., Inc. We want to assist you in every way possible to assure your complete satisfaction with your purchase.

Regional Office Locations

NORTHWEST REGIONAL OFFICE
(includes Alaska)
American Honda Motor Co., Inc.
Customer Relations Department
P.O. Box 30285
Portland, Oregon 97220
Telephone: (503) 255-1186

MIDWEST REGIONAL OFFICE
American Honda Motor Co., Inc.
Customer Relations Department
P.O. Box 22
Greendale, Wisconsin 53129
Telephone: (414) 421-9300

NORTHEAST REGIONAL OFFICE
American Honda Motor Co., Inc.
Customer Relations Department
P.O. Box 749
Moorestown, New Jersey 08057
Telephone: (609) 778-1100

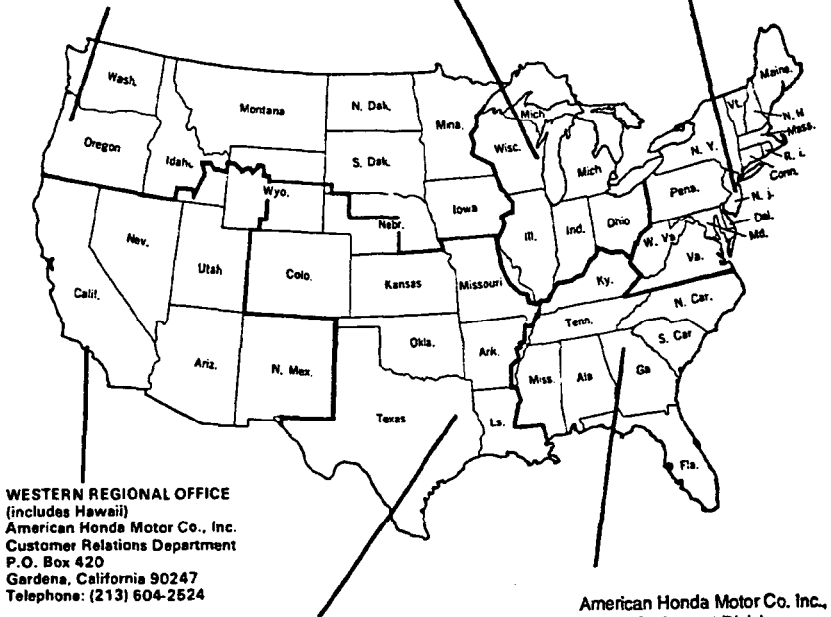

WESTERN REGIONAL OFFICE
(includes Hawaii)
American Honda Motor Co., Inc.
Customer Relations Department
P.O. Box 420
Gardena, California 90247
Telephone: (213) 604-2524

SOUTHWEST REGIONAL OFFICE
American Honda Motor Co., Inc.
Customer Relations Department
P.O. Box 5406
Irving, Texas 75062
Telephone: (214) 258-6883

American Honda Motor Co., Inc.
Power Equipment Division
Customer Relations Office
4900 Marconi Drive
Alpharetta, GA 30005-8847
Telephone: (770) 497-6400

NOTE

HONDA

31899010
00X31-899-0100



Printed on
Recycled Paper

POM 53161

AHM 00809909

PRINTED IN U.S.A.