

**Serial Number**

**QT**

**2.5L**

**25kW**

**Model: 005213-0**

**STANDBY GENERATOR  
OWNER'S MANUAL**

*A new standard of reliability*

<b>SECTION</b>	<b>PAGE</b>		<b>PAGE</b>
<b>SAFETY RULES</b> .....	<b>1-1</b>	<b>OPERATION</b> .....	<b>9-1</b>
<b>INTRODUCTION</b> .....	<b>1-3</b>	Generator Control and Operation .....	9-1
Read this Manual Thoroughly .....	1-3	Operating Unit with Manual Transfer Switch .....	9-1
Operation and Maintenance .....	1-3	Engine Start-up and Transfer .....	9-1
How to Obtain Service .....	1-3	Retransfer and Shutdown .....	9-1
<b>IDENTIFICATION RECORD</b> .....	<b>2-1</b>	Operating Unit with Automatic Transfer Switch .....	9-1
Data Label .....	2-1	<b>MAINTENANCE</b> .....	<b>10-1</b>
<b>EQUIPMENT DESCRIPTION</b> .....	<b>3-1</b>	Maintenance Performed by Authorized	
Equipment Description .....	3-1	Service Facilities .....	10-1
Engine Oil Recommendations .....	3-1	Every Three Months .....	10-1
Coolant Recommendations .....	3-1	Once Every Six Months .....	10-1
<b>ENGINE PROTECTIVE DEVICES</b> .....	<b>4-1</b>	Once Annually .....	10-1
High Coolant Temperature Switch .....	4-1	First 100 Operating Hours .....	10-1
Low Coolant Level Sensor .....	4-1	Every 500 Operating Hours .....	10-1
Low Oil Pressure Switch .....	4-1	Every 800 Operating Hours .....	10-1
Overcrank Shutdown .....	4-1	Exhaust Manifold Procedure .....	10-1
Overspeed Shutdown .....	4-1	Intake Manifold Procedure .....	10-1
RPM Sensor Loss Shutdown .....	4-1	Cylinder Head Procedure .....	10-1
DC Fuse .....	4-1	Cooling System .....	10-2
<b>FUEL SYSTEMS</b> .....	<b>5-1</b>	Overload Protection for Engine DC	
Fuel Requirements .....	5-1	Electrical System .....	10-2
Natural Gas Fuel System .....	5-1	Checking Fluid Levels .....	10-2
Propane Vapor Withdrawal Fuel System .....	5-1	Check Engine Oil .....	10-2
LP Fuel System .....	5-1	Battery Fluid .....	10-2
<b>SPECIFICATIONS</b> .....	<b>6-1</b>	Engine Coolant .....	10-2
Generator .....	6-1	Maintenance Owner/Operator Can Perform .....	10-3
Engine .....	6-1	Check Engine Oil Level .....	10-3
Cooling System .....	6-1	Check Battery .....	10-3
Fuel System .....	6-1	Exercise System .....	10-3
Electrical System .....	6-1	Inspect Cooling System .....	10-3
Cold Weather Kit .....	6-2	Check Engine Coolant Level .....	10-3
Reconfiguring the Fuel System .....	6-2	Perform Visual Inspection .....	10-3
<b>GENERAL INFORMATION</b> .....	<b>7-1</b>	Inspect Exhaust System .....	10-3
Generator AC Lead Connections .....	7-1	Check Fan Belt .....	10-3
Four-lead, Single-phase Stator .....	7-1	Inspect Engine Governor .....	10-3
Alternator Power Winding Connections .....	7-1	Changing Engine Oil .....	10-3
3-phase Alternators .....	7-1	Changing the Engine Air Cleaner .....	10-3
<b>INSTALLATION</b> .....	<b>8-1</b>	Spark Plugs .....	10-4
Installation .....	8-1	Coolant Change .....	10-4
Preparation Before Start-up .....	8-1	Miscellaneous Maintenance .....	10-4
Transfer Switch .....	8-1	Cleaning the Generator .....	10-4
Fuel System .....	8-1	Battery .....	10-4
Generator Set Lubrication .....	8-1	Battery Maintenance .....	10-4
Prior to Initial Start-up .....	8-1	Battery Replacement .....	10-5
Engine Coolant .....	8-1	<b>SERVICE SCHEDULE</b> .....	<b>11-1</b>
Belt Tension .....	8-1	<b>TROUBLESHOOTING</b> .....	<b>12-1</b>
Electrical System .....	8-1	Troubleshooting Guide .....	12-1
Initial Inspection for QT Genset Start-up .....	8-1	<b>NOTES</b>	
Start-up Checklist .....	8-2	<b>EXPLODED VIEWS &amp; PARTS LISTS</b>	
Preparation for Start-up .....	8-2	<b>WIRING DIAGRAMS &amp; SCHEMATICS</b>	
Start-up Inspection .....	8-2	<b>WARRANTY</b>	



## Standby Generator Sets Important Safety Instructions



**⚠ SAVE THESE INSTRUCTIONS** – *The manufacturer suggests that these rules for safe operation be copied and posted in potential hazard areas. Safety should be stressed to all operators, potential operators, and service and repair technicians for this equipment.* **⚠**



### WARNING:



**The engine exhaust from this product contains chemicals known to the state of California to cause cancer, birth defects or other reproductive harm.**



### WARNING:



**This product contains or emits chemicals known to the state of California to cause cancer, birth defects or other reproductive harm.**

Study these SAFETY RULES carefully before installing, operating or servicing this equipment. Become familiar with this Owner's Manual and with the unit. The generator can operate safely, efficiently and reliably only if it is properly installed, operated and maintained. Many accidents are caused by failing to follow simple and fundamental rules or precautions.

The manufacturer cannot anticipate every possible circumstance that might involve a hazard. The warnings in this manual, and on tags and decals affixed to the unit are, therefore, not all inclusive. If a procedure, work method or operating technique is used that the manufacturer does not specifically recommend, ensure that it is safe for others. Also make sure the procedure, work method or operating technique utilized does not render the generator unsafe.

### ⚠ DANGER ⚠

- ⚠** Despite the safe design of this generator, operating this equipment imprudently, neglecting its maintenance or being careless can cause possible injury or death. Permit only responsible and capable persons to install, operate or maintain this equipment.
- ⚠** Potentially lethal voltages are generated by these machines. Ensure all steps are taken to render the machine safe before attempting to work on the generator.
- ⚠** Parts of the generator are rotating and/or hot during operation. Exercise care near running generators.

### ⚠ GENERAL HAZARDS ⚠

- For safety reasons, the manufacturer recommends that this equipment be installed, serviced and repaired by an Authorized Service Dealer or other competent, qualified electrician or installation technician who is familiar with applicable codes, standards and regulations. The operator also must comply with all such codes, standards and regulations.
- Installation, operation, servicing and repair of this (and related) equipment must always comply with applicable codes, standards, laws and regulations. Adhere strictly to local, state and national electrical and building codes. Comply with regulations the Occupational Safety and Health Administration (OSHA) has established. Also, ensure that the generator is installed, operated and serviced in accordance with the manufacturer's instructions and recommendations. Following installation, do nothing that might render the unit unsafe or in noncompliance with the aforementioned codes, standards, laws and regulations.
- The engine exhaust fumes contain carbon monoxide gas, which can be DEADLY. This dangerous gas, if breathed in sufficient concentrations, can cause unconsciousness or even death. For that reason, adequate ventilation must be provided. Exhaust gases must be piped safely away from any building or enclosure that houses the generator to an area where people, animals, etc., will not be harmed. This exhaust system must be installed properly, in strict compliance with applicable codes and standards.
- Keep hands, feet, clothing, etc., away from drive belts, fans, and other moving or hot parts. Never remove any drive belt or fan guard while the unit is operating.
- Adequate, unobstructed flow of cooling and ventilating air is critical in any room or building housing the generator to prevent buildup of explosive gases and to ensure correct generator operation. Do not alter the installation or permit even partial blockage of ventilation provisions, as this can seriously affect safe operation of the generator.
- Keep the area around the generator clean and uncluttered. Remove any materials that could become hazardous.
- When working on this equipment, remain alert at all times. Never work on the equipment when physically or mentally fatigued.
- Inspect the generator regularly, and promptly repair or replace all worn, damaged or defective parts using only factory-approved parts.



## Standby Generator Sets Important Safety Instructions



- Before performing any maintenance on the generator, disconnect its battery cables to prevent accidental start-up. Disconnect the cable from the battery post indicated by a NEGATIVE, NEG or (-) first. Reconnect that cable last.
- Never use the generator or any of its parts as a step. Stepping on the unit can stress and break parts, and may result in dangerous operating conditions from leaking exhaust gases, fuel leakage, oil leakage, etc.

### **ELECTRICAL HAZARDS**

- All generators covered by this manual produce dangerous electrical voltages and can cause fatal electrical shock. Utility power delivers extremely high and dangerous voltages to the transfer switch as well as the standby generator. Avoid contact with bare wires, terminals, connections, etc., on the generator as well as the transfer switch, if applicable. Ensure all appropriate covers, guards and barriers are in place before operating the generator. If work must be done around an operating unit, stand on an insulated, dry surface to reduce shock hazard.
- Do not handle any kind of electrical device while standing in water, while barefoot, or while hands or feet are wet. DANGEROUS ELECTRICAL SHOCK MAY RESULT.
- If personnel must stand on metal or concrete while installing, operating, servicing, adjusting or repairing this equipment, place insulative mats over a dry wooden platform. Work on the equipment only while standing on such insulative mats.
- The National Electrical Code (NEC) requires the frame and external electrically conductive parts of the generator to be connected to an approved earth ground. This grounding will help prevent dangerous electrical shock that might be caused by a ground fault condition in the generator set or by static electricity. Never disconnect the ground wire.
- Wire gauge sizes of electrical wiring, cables and cord sets must be adequate to handle the maximum electrical current (ampacity) to which they will be subjected.
- Before installing or servicing this (and related) equipment, make sure that all power voltage supplies are positively turned off at their source. Failure to do so will result in hazardous and possibly fatal electrical shock.
- Connecting this unit to an electrical system normally supplied by an electric utility shall be by means of a transfer switch so as to isolate the generator electric system from the electric utility distribution system when the generator is operating. Failure to isolate the two electric system power sources from each other by such means will result in damage to the generator and may also result in injury or death to utility power workers due to backfeed of electrical energy.
- Generators installed with an automatic transfer switch will crank and start automatically when normal (utility) source voltage is removed or is below an acceptable preset level. To prevent such automatic start-up and possible injury to personnel, disable the generator's automatic start circuit (battery cables, etc.) before working on or around the unit. Then, place a "Do Not Operate" tag on the generator control panel and on the transfer switch.
- In case of accident caused by electric shock, immediately shut down the source of electrical power. If this is not possible, attempt to free the victim from the live conductor. AVOID DIRECT CONTACT WITH THE VICTIM. Use a nonconducting implement, such as a dry rope or board, to free the victim from the live conductor. If the victim is unconscious, apply first aid and get immediate medical help.
- Never wear jewelry when working on this equipment. Jewelry can conduct electricity resulting in electric shock, or may get caught in moving components causing injury.

### **FIRE HAZARDS**

- Keep a fire extinguisher near the generator at all times. Do NOT use any carbon tetra-chloride type extinguisher. Its fumes are toxic, and the liquid can deteriorate wiring insulation. Keep the extinguisher properly charged and be familiar with its use. If there are any questions pertaining to fire extinguishers, consult the local fire department.

### **EXPLOSION HAZARDS**

- Properly ventilate any room or building housing the generator to prevent build-up of explosive gas.
- Do not smoke around the generator. Wipe up any fuel or oil spills immediately. Ensure that no combustible materials are left in the generator compartment, or on or near the generator, as FIRE or EXPLOSION may result. Keep the area surrounding the generator clean and free from debris.
- These generator sets may operate using one of several types of fuels. All fuel types are potentially FLAMMABLE and/or EXPLOSIVE and should be handled with care. Comply with all laws regulating the storage and handling of fuels. Inspect the unit's fuel system frequently and correct any leaks immediately. Fuel supply lines must be properly installed, purged and leak tested according to applicable fuel-gas codes before placing this equipment into service.
- Diesel fuels are highly FLAMMABLE. Gaseous fluids such as natural gas and liquid propane (LP) gas are extremely EXPLOSIVE. Natural gas is lighter than air, and LP gas is heavier than air; install leak detectors accordingly.



## INTRODUCTION

Thank you for purchasing this model of the standby generator set product line.

Every effort was expended to make sure that the information and instructions in this manual were both accurate and current at the time the manual was written. However, the manufacturer reserves the right to change, alter or otherwise improve this product(s) at any time without prior notice.

### ◆ READ THIS MANUAL THOROUGHLY

If any portion of this manual is not understood, contact the nearest Authorized Service Dealer for starting, operating and servicing procedures.

Throughout this publication, and on tags and decals affixed to the generator, DANGER, WARNING, CAUTION and NOTE blocks are used to alert personnel to special instructions about a particular service or operation that may be hazardous if performed incorrectly or carelessly. Observe them carefully. Their definitions are as follows:



After this heading, read instructions that, if not strictly complied with, will result in personal injury or property damage.



After this heading, read instructions that, if not strictly complied with, may result in personal injury or property damage.



After this heading, read instructions that, if not strictly complied with, could result in damage to equipment and/or property.

#### NOTE:

After this heading, read explanatory statements that require special emphasis.

These safety warnings cannot eliminate the hazards that they indicate. Common sense and strict compliance with the special instructions while performing the service are essential to preventing accidents.

Four commonly used safety symbols accompany the DANGER, WARNING and CAUTION blocks. The type of information each indicates is as follows:

 This symbol points out important safety information that, if not followed, could endanger personal safety and/or property of others.

 This symbol points out potential explosion hazard.

 This symbol points out potential fire hazard.

 This symbol points out potential electrical shock hazard.

The operator is responsible for proper and safe use of the equipment. The manufacturer strongly recommends that the operator read this Owner's Manual and thoroughly understand all instructions before using this equipment. The manufacturer also strongly recommends instructing other users to properly start and operate the unit. This prepares them if they need to operate the equipment in an emergency.

### ◆ OPERATION AND MAINTENANCE

It is the operator's responsibility to perform all safety checks, to make sure that all maintenance for safe operation is performed promptly, and to have the equipment checked periodically by an Authorized Service Dealer. Normal maintenance service and replacement of parts are the responsibility of the owner/operator and, as such, are not considered defects in materials or workmanship within the terms of the warranty. Individual operating habits and usage contribute to the need for maintenance service.

Proper maintenance and care of the generator ensure a minimum number of problems and keep operating expenses at a minimum. See an Authorized Service Dealer for service aids and accessories.

Operating instructions presented in this manual assume that the standby electric system has been installed by an Authorized Service Dealer or other competent, qualified contractor. Installation of this equipment is not a "do-it-yourself" project.

### ◆ HOW TO OBTAIN SERVICE

When the generator requires servicing or repairs, simply contact an Authorized Service Dealer for assistance. Service technicians are factory-trained and are capable of handling all service needs.

When contacting an Authorized Service Dealer or the factory about parts and service, always supply the complete model number of the unit as given on the front cover of this manual or on the DATA LABEL affixed to the unit.

#### AUTHORIZED SERVICE DEALER LOCATION

To locate the nearest AUTHORIZED SERVICE DEALER, please call this number:

**1-800-333-1322**

or locate us on the web at:

**www.generac.com**

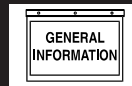
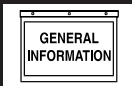

## IDENTIFICATION RECORD

### ◆ DATA LABEL

Every generator set has a DATA LABEL that contains important information pertinent to the generator. The data label, which can be found attached to the generator's lower connection box, lists the unit's serial number and its rated voltage, amps, wattage capacity, phase, frequency, rpm, power factor, etc.

### NOTE:

For actual information related to this particular model, please refer to the Manual Drawing Listing located at the end of this manual, or to the data label affixed to the unit.

#### ✦ Generator Model and Serial Number

This number is the key to numerous engineering and manufacturing details pertaining to your unit. Always supply this number when requesting service, ordering parts or seeking information.

### *Data Label*

<b>GENERATOR SET DATA</b>		<b>MADE IN USA</b>
MODEL	<input style="width: 150px;" type="text"/>	SERIAL <input style="width: 150px;" type="text"/>
RATED KW	<input style="width: 60px;" type="text"/>	RATED KVA <input style="width: 60px;" type="text"/> PHASE <input style="width: 60px;" type="text"/>
RATED VOLTAGE	<input style="width: 100px;" type="text"/>	RATED AMPS <input style="width: 100px;" type="text"/>
POWER FACTOR	<input style="width: 60px;" type="text"/>	HERTZ <input style="width: 60px;" type="text"/> ALT RPM <input style="width: 60px;" type="text"/>
ENGINE RPM	<input style="width: 100px;" type="text"/>	PRODUCTION DATE <input style="width: 100px;" type="text"/>
ALTERNATOR SUBTRANSIENT REACTANCE		<input style="width: 100px;" type="text"/>
ALTERNATOR TRANSIENT REACTANCE		<input style="width: 100px;" type="text"/>
CLASS <input type="checkbox"/>	ROTOR <input type="checkbox"/>	STATOR WINDING INSULATION AT 25°C AMBIENT
<b>GENERAC POWER SYSTEMS, INC.</b> <b>WAUKESHA, WI</b>		

## EQUIPMENT DESCRIPTION

This equipment is a revolving field, alternating current generator set. It is powered by a gaseous fueled engine operating at 1800 rpm for 4-pole direct drive units, 3600 rpm for 2-pole direct drive units and 2300 - 3000 rpm for quiet drive gear units. See the Specifications section for exact numbers. The unit comes complete with a sound attenuated enclosure, internally mounted muffler, control console, main-line circuit breaker, battery charger, and protective alarms as explained in the following paragraph.

All AC connections, including the power leads from the alternator, 120 volt battery charger input and control connections to the transfer switch are available in the main connection box.

The generator incorporates the following generator features:

- Rotor and Stator insulation is Class H rated as defined by NEMA MG1-32.6, NEMA MG1-1.66. The generator is self ventilated and drip-proof constructed.
- The voltage waveform deviation, total harmonic content of the AC waveform and telephone influence factor have been evaluated and are acceptable according to NEMA MG1-32.

## ENGINE OIL RECOMMENDATIONS

The unit has been filled with 15W-40 engine oil at the factory. Use a high-quality detergent oil classified "For Service CC, SD, SE, SF." Detergent oils keep the engine cleaner and reduce carbon deposits. Use oil having the following SAE viscosity rating, based on the ambient temperature range anticipated before the next oil change:

Temperature	Oil Grade (Recommended)
Above 80° F (27° C)	SAE 30W or 15W-40
32° to 80° F (0° to 27° C)	SAE 20W-20 or 15W-40
Below 32° F (0° C)	See Note

—  CAUTION  —

 Any attempt to crank or start the engine before it has been properly serviced with the recommended oil may result in an engine failure.

**NOTE:**

**For temperatures below 32° F, it is strongly recommended to use the optional Cold Weather Start Kit (part number listed in the Specification Section). The oil grade for temperatures below 32° F is 5W-30 synthetic oil.**

## COOLANT RECOMMENDATIONS

Use a mixture of half low silicate ethylene glycol base anti-freeze and deionized water. Cooling system capacity is listed in the specifications. Use only deionized water and only low silicate anti-freeze. If desired, add a high quality rust inhibitor to the recommended coolant mixture. When adding coolant, always add the recommended 50-50 mixture.

—  CAUTION  —

 Do not use any chromate base rust inhibitor with ethylene glycol base anti-freeze or chromium hydroxide ("green slime") forms and will cause overheating. Engines that have been operated with a chromate base rust inhibitor must be chemically cleaned before adding ethylene glycol base anti-freeze. Using any high silicate anti-freeze boosters or additives will also cause overheating. The manufacturer also recommends that any soluble oil inhibitor is NOT used for this equipment.

—  **DANGER**  —

 Do not remove the radiator pressure cap while the engine is hot or serious burns from boiling liquid or steam could result.

 Ethylene glycol base antifreeze is poisonous. Do not use mouth to siphon coolant from the radiator, recovery bottle or any container. Wash hands thoroughly after handling. Never store used antifreeze in an open container because animals are attracted to the smell and taste of antifreeze even though it is poisonous to them.

## ENGINE PROTECTIVE DEVICES

The standby generator may be required to operate for long periods of time without an operator on hand to monitor such engine conditions as coolant temperature, oil pressure or rpm. For that reason, the engine has several devices designed to protect it against potentially damaging conditions by automatically shutting down the unit when the oil pressure is too low, the coolant temperature is too high, the coolant level is too low, or the engine is running too fast.

### NOTE:

Protective switches and sensors are mentioned here for the reader's convenience. Also refer to the applicable control panel manual for additional automatic engine shutdown information.

### ◆ HIGH COOLANT TEMPERATURE SWITCH

This switch contacts close if the temperature should exceed approximately 140° C (284° F), initiating an engine shutdown. The generator will automatically restart and the LED will reset once the temperature has returned to a safe operating level.

### ◆ LOW COOLANT LEVEL SENSOR

Should the engine coolant level drop below the level of the high coolant temperature switch, it is possible for the engine to overheat without automatic shutdown. To prevent such overheating, the engine has a low coolant level sensor. If the level of engine coolant drops below the level of the low coolant level sensor, the engine automatically shuts down.

### ◆ LOW OIL PRESSURE SWITCH

This switch has normally closed contacts that are held open by engine oil pressure during cranking and operating. Should oil pressure drop below the 8 psi range, switch contacts close, and the engine shuts down. The unit should not be restarted until oil is added, and the AUTO/OFF/MANUAL switch must be turned to OFF and then back to AUTO.

### ◆ OVERCRANK SHUTDOWN

After a prespecified duration of cranking, this function ends the cranking if the engine has failed to start. The overcrank LED will turn ON. Turn OFF the AUTO/OFF/MANUAL switch, then turn switch back to AUTO to reset the generator control board.

### NOTE:

**If the fault is not corrected, the overcrank feature will continue to activate.**

### Approximate Crank Cycle Times

- 15 seconds ON
  - 7 seconds OFF
  - 7 seconds ON
  - 7 seconds OFF
  - Repeat for 45 seconds
- Approximately 90 seconds total.

### ◆ OVERSPEED SHUTDOWN

A speed circuit controls engine cranking, start-up, operation and shutdown. Engine speed signals are delivered to the circuit board whenever the unit is running. Should the engine overspeed above a safe, preset value, the circuit board initiates an automatic engine shutdown. Contact the nearest Authorized Dealer if this failure occurs.

### ◆ RPM SENSOR LOSS SHUTDOWN

If the speed signal to the control panel is lost, engine shutdown will occur.

### ◆ DC FUSE

This fuse is located inside of the control panel. It protects the panel wiring and components from damaging overload. **Always remove this fuse before commencing work on the generator.** The unit will not start or crank if the fuse is blown. Replace the fuse with one of the same size, type, and rating. (See the exploded views and parts lists at the end of this manual for replacement part number.)



## FUEL SYSTEM

### FUEL REQUIREMENTS

The standby generator may be equipped with one of the following fuel systems:

- Natural gas fuel system
- Propane vapor (PV) fuel system

The Manual Drawing Listing that is affixed to the unit includes the "Identification Code," which may be used to identify the type of fuel system installed on the unit.

Recommended fuels should have a Btu content of at least 1,000 Btus per cubic foot for natural gas; or at least 2,520 Btus per cubic foot for LP gas. Ask the fuel supplier for the Btu content of the fuel.

Required fuel pressure for **natural gas is 5 inches to 14 inches water column (0.18 to 0.5 psi); and for liquid propane, 5 inches to 14 inches of water column (0.18 to 0.5 psi).**

#### NOTE:

**Any piping used to connect the generator to the fuel supply should be of adequate size to ensure the fuel pressure NEVER drops below five inches water column for natural gas or 5 inches water column for propane vapor for all load ranges.**

#### NOTE:

**It is the responsibility of the installer to make sure that only the correct recommended fuel is supplied to the generator fuel system. Thereafter, the owner/operator must make certain that only the proper fuel is supplied.**

### NATURAL GAS FUEL SYSTEM

Natural gas is supplied in its vapor state. In most cases, the gas distribution company provides piping from the main gas distribution line to the standby generator site. The following information applies to natural gas fuel systems.

- Gas pressure in a building is usually regulated by national, state and local codes.
- To reduce gas pressure

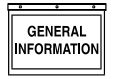

# Standby Generator Sets Specifications



## SPECIFICATIONS

### ◆ GENERATOR

Type ..... Synchronous  
 Rotor Insulation ..... Class H  
 Stator Insulation ..... Class H  
 Total Harmonic Distortion ..... < 3.5%  
 Telephone Interference Factor (TIF) ..... < 50  
 Alternator Output Leads 3-phase ..... 4-wire  
 Bearings ..... Sealed Ball  
 Coupling ..... Flexible Disc  
 Load Capacity (Standby Rating) ..... 25kW\*

\* NOTE: Generator rating and performance in accordance with ISO8528-5, BS5514, SAE J1349, ISO3046 and DIN 6271 Standards. KW rating is based on LPG fuel and may derate with natural gas.

Excitation System ..... Direct  
 Generator Output Voltage/kW - 60 Hz

	kW	Amp	CB Size
120/240V, 1-phase, 1.0 pf	25	104	125
120/208V, 3-phase, 0.8 pf	25	85	100

Generator Locked Rotor KVA Available @ Voltage Dip of 35%  
 Single-phase or 208 3-phase ..... 38 KVA

### ◆ ENGINE

Make ..... Generac  
 Model ..... In Line  
 Cylinders and Arrangement ..... 4  
 Displacement ..... 2.5 Liter  
 Bore ..... 3.78 in.  
 Stroke ..... 3.4 in.  
 Compression Ratio ..... 9.4-to-1  
 Air Intake System ..... Naturally Aspirated  
 Valve Seats ..... Replaceable  
 Lifter Type ..... Overhead Cam Rocker Arm/Hydraulic Lifter

#### Engine Parameters

Rated Synchronous RPM ..... 60 Hz, 1800  
 HP at rated kW ..... 60 Hz, 40

#### Exhaust System

Exhaust Flow at Rated Output 60 Hz ..... 227 cfm  
 Exhaust Temperature at Rated Output ..... 1000° F

#### Combustion Air Requirements (Natural Gas)

Flow at rated power, 60 Hz ..... 67.5 cfm

#### Governor

Type ..... Electronic  
 Frequency Regulation ..... Isochronous  
 Steady State Regulation ..... ± 0.25%

#### Engine Lubrication System

Type of Oil Pump ..... Gear  
 Oil Filter ..... Full Flow Spin-on, Cartridge  
 Crankcase Oil Capacity ..... 4 U.S. qts.

### ◆ COOLING SYSTEM

Type ..... Pressurized Closed Recovery  
 Water Pump ..... Belt Driven  
 Fan Speed ..... 2090 rpm  
 Fan Diameter ..... 16 inches  
 Fan Mode ..... Pusher  
 Air Flow (inlet air including alternator and combustion air) ..... 1438 ft<sup>3</sup>/min.  
 Coolant Capacity ..... (3.0 U.S. gal.)  
 Heat Rejection to Coolant ..... 95,000 Btu/h  
 Maximum Operating Air Temp. on Radiator ..... 60° C (150° F)  
 Maximum Ambient Temperature ..... 50° C (140° F)

### ◆ FUEL SYSTEM

Type of Fuel ..... Natural Gas, Propane Vapor  
 Carburetor ..... Down Draft  
 Secondary Fuel Regulator ..... Standard  
 Fuel Shut-off Solenoid ..... Standard  
 Operating Fuel Pressure ..... 5 in. - 14 in. Water Column

#### Fuel Consumption - ft<sup>3</sup>/hr (Natural Gas/LPV)

Exercise Cycle	25% Load	50% Load	75% Load	100% Load
60/24	140/56	220/87	300/119	380/151

### ◆ ELECTRICAL SYSTEM

Battery Charge Alternator ..... 12V, 30 Amp  
 Static Battery Charger ..... 2 Amp  
 Recommended Battery ..... Group 26, 525CCA  
 System Voltage ..... 12 Volts

#### Voltage Regulator

Type ..... Electronic  
 Sensing ..... Single-phase  
 Regulation ..... ± 1%  
 Features ..... V/F Adjustable, Adjustable Voltage and Gain LED Indicators

#### Power Adjustment for Ambient Conditions

Temperature Deration  
 3% for every 10° C above °C ..... 25  
 1.65% for every 10° above °F ..... 77  
 Altitude Deration  
 1% for every 100 m above m ..... 183  
 3% for every 1000 ft. above ft. .... 600

Controller ..... **R-100**

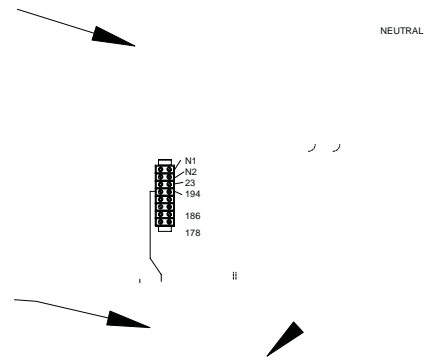
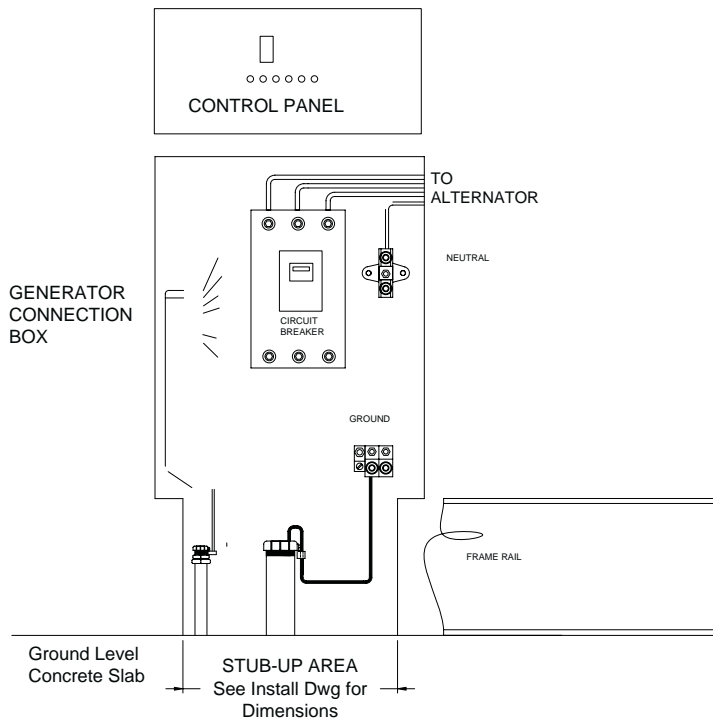

### ◆ COLD WEATHER KIT

For cold climates, optional cold weather kit (part number 0F6148) is recommended. The kit includes:

- Battery Warmer
- 4" Junction Box with hardware
- 6 qt. pack 5W-30 synthetic oil (engine)

### ◆ RECONFIGURING THE FUEL SYSTEM

**NOTE:**

**All models are configured for natural gas or LP vapor from the factory.**

To reconfigure the fuel system from NG to LP, follow these steps:

1. Turn the main gas supply off.
2. Remove the carburetor fuel hose from the outlet port (Port 1) of the demand regulator (Figure 6.2).
3. Remove the brass hose fitting from the outlet port (Port 1) of the demand regulator.
4. Remove pipe plug from Port 2.
5. Install brass hose fitting into Port 2.
6. Install pipe plug into Port 1.
7. Connect carburetor gas hose to brass fitting.
8. Tighten all clamps and plugs.
9. Make sure fuel supply is of the proper pressure and type for configuration.

10. Reverse the procedure to convert back to natural gas.

11. The Dip switch inside the control panel must be in the LP or NG position when switching to different fuels.

**Figure 6.2 — Reconfigure the Fuel System**

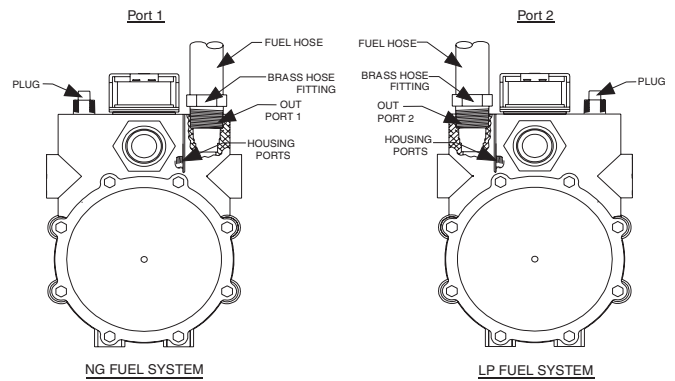

**NOTE:**

**Port 1 is for NG only and Port 2 is for LP vapor only. No provision for dual fuel has been made.**



⚠ **Serious injury or damage may occur if not configured properly. Please consult an Authorized Service Dealer with any questions.**

## GENERATOR AC LEAD CONNECTIONS

See "Voltage Codes". This generator may be rated at any one of three voltages, either single-phase or three-phase. The electrical wires in the unit's AC connection (lower) panel should be installed according to the number of leads and the voltage/phase required for the application. If there are any questions regarding lead connection, refer to the wiring diagrams at the back of this manual.

Voltage codes apply to the type of stator assembly installed on a particular generator.

### ◆ FOUR-LEAD, SINGLE-PHASE STATOR

Four-lead generators (see Figure 7.1) are designed to supply electrical loads with voltage code "A" (240V, 1-phase, 60 Hz). Electrical power is produced in the stator power windings. These windings were connected at the factory to the main circuit breaker as shown in Figure 7.1.

The rated voltage between each circuit breaker terminal is 240V. The rated voltage between each circuit breaker terminal and the neutral point 00 is 120V.

Figure 7.1 — Four-lead, Single-phase Stator

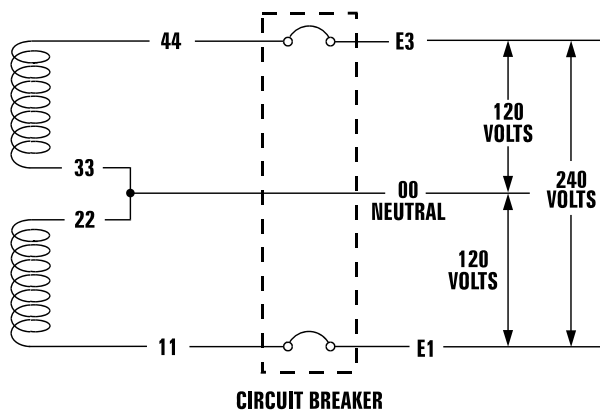

## ALTERNATOR POWER WINDING CONNECTIONS

### ◆ 3-PHASE ALTERNATORS

The generator is designed to supply 3-phase electrical loads. Electric power is produced in the alternator power windings. These windings were connected at the factory to the main circuit breaker with a "Y" configuration as shown in Figures 7.2 and 7.3.

The rated voltage between circuit breaker terminals E1-E2, E1-E3 and E2-E3 is either 480V or 208V depending on the model.

The rated voltage between each circuit breaker terminal and the neutral point 00 is either 277V or 120V depending on the model.

Figure 7.2 — Stator Power Winding Connections - 3-phase, 277/480V (6 Lead)

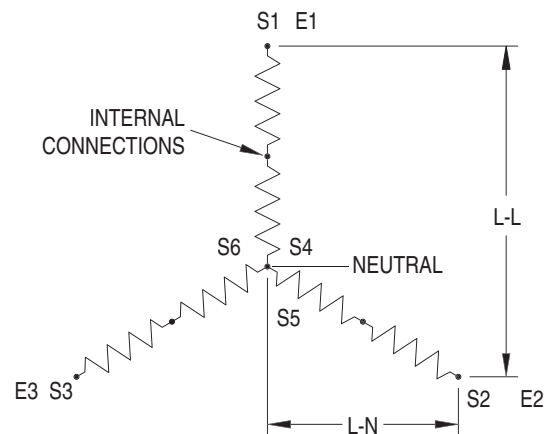
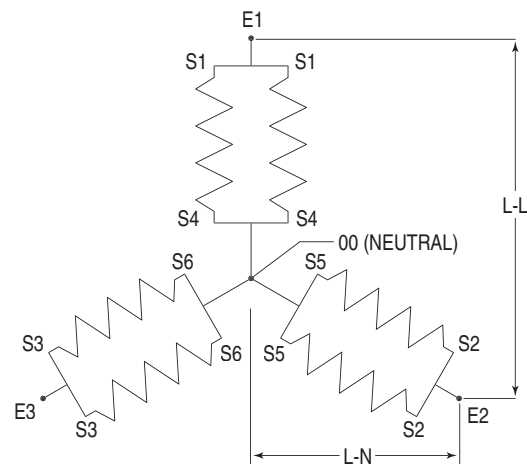

Figure 7.3 — Stator Power Winding Connections - 3-phase, 120/208V (6 Lead)





## INSTALLATION

Refer to the separate “Installation Guide QT Product Line” supplied with the unit.

## PREPARATION BEFORE START-UP

The instructions in this section assume that the standby generator has been properly installed, serviced, tested, adjusted and otherwise prepared for use by a competent, qualified installation contractor. Be sure to read the “Safety Rules”, as well as all other safety information in this manual, before attempting to operate this (and related) equipment.

Before starting the generator for the first time, the installer must complete the following procedures. For follow-up maintenance information and/or service intervals, please refer to the “Maintenance” section and the “Service Schedule”.

### ◆ TRANSFER SWITCH

If this generator is used to supply power to any electrical system normally powered by an electric utility, the National Electrical Code requires that a transfer switch be installed. The transfer switch prevents electrical backfeed between two different electrical systems. (For additional information, see the applicable transfer switch manual for this unit.) The transfer switch, as well as the generator and other standby components, must be properly located and mounted in strict compliance with applicable codes, standards and regulations.

### ◆ FUEL SYSTEM

Make sure the fuel supply system to the generator (a) delivers the correct fuel at the correct pressure and (b) is properly purged and leak tested according to code. No fuel leakage is permitted. See “Specifications” for more information.

### ◆ GENERATOR SET LUBRICATION

Check the engine crankcase oil level before operating and add oil to the proper level – the dipstick “FULL” mark. Never operate the engine with the oil level below the dipstick “ADD” mark. See “Specifications” and “Engine Oil Recommendations”.

#### NOTE:

**This engine is shipped from the manufacturer with “break-in” oil. This oil should be changed after 30 hours of operation.**

Check the oil level in the generator gearbox (if so equipped) prior to initial use and at the intervals indicated by the “Service Schedule.” The recommended oil is SAE 90 gear lubricant.

Also, if the engine is equipped with a mechanical governor, make sure the governor is properly lubricated with clean engine oil.

## ◆ PRIOR TO INITIAL START-UP



- ⚠ Prior to initially starting the generator, it must be properly prepared for use. Any attempt to crank or start the engine before it has been properly serviced with the recommended types and quantities of engine fluids (oil, coolant, fuel, etc.) may result in an engine failure.

### ◆ ENGINE COOLANT

Have the engine cooling system properly filled with the recommended coolant mixture. Check the system for leaks and other problems. See “Specifications” and “Coolant” sections.

### ◆ BELT TENSION

Check the engine-fan belt tension and condition prior to placing the unit into service and at recommended intervals. Belt tension is correct when a force of approximately 22 pounds (10 kg), applied midway between pulleys, deflects the belt about 3/8- to 5/8-inch (10 to 16 mm).

### ◆ ELECTRICAL SYSTEM

Make sure the generator is properly connected to an approved earth ground.

Make sure the generator battery is fully charged, properly installed and interconnected, and ready for use.

Check to ensure that there are no loose electrical connections. Restrain any loose wires to keep them clear of any moving generator set components.

## INITIAL INSPECTION FOR QT GENSET STARTUP

Inspect for the following.

- Freight Damage.
- Manuals present.
- Fluid Levels ( Oil, coolant, battery, Gear Drive).
- Correct fuel piping.
- Correct muffler installation for QT50, QT70, QT100 - QT150.
- Adequate air flow, clearances and ventilation per installation drawings and applicable codes.
- Correct AC and DC wire size, connections and grounding. Control and communication wiring to/from the transfer switch must be run in a separate conduit from the AC power leads.
- Battery charger connection to 120 VAC.
- Communication wires connected between transfer switch and generator (HTS only).
- Unit secured to pad.



## START-UP CHECKLIST



### WARNING

⚠ Before working on the generator, ensure the following:

- The **AUTO/OFF/MANUAL** switch is in the **OFF** position.
- The **120VAC** supply to the battery charger is switched **OFF**.

### ◆ PREPARATION FOR START-UP

- Ensure that the 120VAC circuit breaker to the battery charger is open.
- Remove the fuse from the the control panel. For the H-100 and R-100: Open the front door of the control box and remove the 15 Amp ATO fuse in the lower left-hand corner of the control box.
- Connect the battery cables to the battery. Attach negative battery cable last.
- Close the 120VAC circuit breaker to the battery charger.
- Measure the voltage at the battery before and after the charger is turned on.
- Verify all AC electrical connections are tight at the circuit breaker and transfer switch.
- Visually inspect entire area looking for loose paper, plastic wrappings, leaves, etc.
- Check all hoses clamps fittings for leaks or damage.
- Check all electrical plugs throughout the generator. Ensure each plug is seated correctly and fully inserted into its receptacle.
- Verify the **AUTO/OFF/MANUAL** switch is in **OFF** position.
- Open the valve to the engine fuel line.
- Bleed the fuel system of air. (necessary for long fuel lines).
- Open the generator main line circuit breaker.
- Connect a manometer to the gas line and record the static pressure. It must be as listed in the Specifications.
- Insert the fuse into the control panel.
- Move the **AUTO/OFF/MANUAL** switch to the **MANUAL** position. The engine should now crank and start.

- Check voltage at the generator terminals.
- For 3-phase units, check phase rotation at the transfer switch terminals. The generator phase rotation must match the utility phase rotation.
- Check for coolant, fuel, oil, and exhaust leaks.
- Close the generators main line circuit breaker.
- Turn the generator set off.
- Connect the **UTILITY** supply to the transfer switch.
- Set the **AUTO/OFF/MANUAL** switch to **AUTO**.
- Disconnect utility power before the transfer switch.

Engine should start, transfer to load.

Run at least 15 minutes on generator power. Make certain all 3-phase loads are functioning correctly (correct phase rotation).

- Reconnect Utility power  
Transfer switch will transfer back to Utility and engine will shut down within the given time parameters set up for the specific transfer switch and controller.
- Install all covers, access plates and door panels.
- Put the Owners Manual in a safe and accessible place.
- Make certain the **AUTO/OFF/MANUAL** switch is in the **AUTO** position.

### ◆ START-UP INSPECTION

When a start-up is performed by an Authorized Service Dealer, a standard three-part form titled "Start-up Inspection for Standby Power Systems" (part no. 067377), should be completed by the installation technician or engineer. See page 1-3 for information on locating the nearest Authorized Service Dealer. The installer should complete the form and disseminate copies as follows:

- White copy: Mail to Generac Warranty Department, P.O. Box 340, 211 Murphy Dr., Eagle, WI 53119-2062.
- Pink Copy: For service file of installing dealer.
- Yellow Copy: For the customer's records.

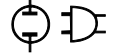
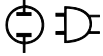

## GENERATOR CONTROL AND OPERATION

Refer to the appropriate control panel operator's manual for this unit.

## OPERATING UNIT WITH MANUAL TRANSFER SWITCH

If the generator was installed in conjunction with a transfer switch capable of manual operation only, the following procedure applies. A manually operated transfer switch is one that will not provide automatic start-up and does not include an intelligence circuit.

### ◆ ENGINE START-UP AND TRANSFER

For additional information, refer to the applicable control panel manual for this unit, as well as any literature pertaining to the specific transfer switch.



- ⚠ The Maintenance Disconnect Switch and the AUTO/OFF/MANUAL switches (if so equipped) must be set properly, or the generator will crank and start as soon as the utility power to the transfer switch is turned off. Refer to applicable control panel and transfer switch manuals for more information.
- ⚠ Do not proceed until certain that utility source voltage is available to the transfer switch and the transfer switch main contacts are set to UTILITY.
- ⚠ Do not attempt manual operation until all power supplies to the transfer switch have been positively turned off, or extremely dangerous - possibly lethal - electrical shock will result.
- ⚠ Transfer switch enclosure doors should be kept closed and locked. Only authorized personnel should be allowed access to the transfer switch interior. Extremely high and dangerous voltages are present in the transfer switch.

In order to transfer load from the utility source to the generator, follow these directions:

- Turn OFF or disconnect the utility power circuit to the transfer switch, using the means provided (such as the utility source main line circuit breaker).
- Set the transfer handle to its UTILITY (NORMAL) position with load circuits connected to the utility power supply.
- Set the standby generator's main line circuit breaker to its OFF (or OPEN) position.
- Start the generator.



### ◆ RETRANSFER AND SHUTDOWN

For additional information, refer to the applicable control panel manual for this unit, as well as any literature pertaining to the specific transfer switch.

To transfer the load back to the utility power source and shut down the generator, follow these directions:

- Set the standby generator's main line circuit breaker to its OFF (or OPEN) position.
- Manually move the transfer switch handle to its UTILITY (NORMAL) position, i.e., load circuits connected to the utility.
- Turn ON the utility power supply to the transfer switch, using the means provided (such as the utility power source main line circuit breaker).
- Let the generator run at no-load for a few minutes to stabilize internal temperatures.
- Shut down the generator.

## OPERATING UNIT WITH AUTOMATIC TRANSFER SWITCH

If the generator has been installed with an automatic transfer switch, such as an RTS, HTS, or GTS-type transfer switch, the engine may be started and stopped automatically or manually.

### NOTE:

**Refer to the applicable manual for your transfer switch and to "Transfer Switch Start Signal Connections". In addition, please note the dangers under "Engine Start-up and Transfer."**



## MAINTENANCE PERFORMED BY AUTHORIZED SERVICE FACILITIES

### ⚠ WARNING ⚠

⚠ Before working on the generator, ensure the following:

- The AUTO/OFF/MANUAL switch is in the OFF position.
- The 15A fuse has been removed from the control box.
- The 120VAC supply to the battery charger is switched OFF.

#### ◆ EVERY THREE MONTHS

1. Check battery condition.
2. Inspect and test fuel system.
3. Check transfer switch.
4. Inspect exhaust system.
5. Check engine ignition system.
6. Check fan belts.

#### ◆ ONCE EVERY SIX MONTHS

1. Test Engine Safety Devices (low oil pressure, low coolant level, high coolant temperature).

#### ◆ ONCE ANNUALLY

1. Test engine governor; adjust or repair, if needed.
2. Clean, inspect generator.
3. Flush cooling system.

#### ◆ FIRST 100 OPERATING HOURS

1. Change engine oil and oil filter. After initial change, service engine oil and filter at 150 operating hours or six months, whichever comes first.
2. Retorque cylinder head.
3. Retorque intake and exhaust manifold.

#### ◆ EVERY 500 OPERATING HOURS

1. Service air cleaner.
2. Check starter.
3. Check engine DC alternator.

#### ◆ EVERY 800 OPERATING HOURS

1. Retorque cylinder head.
2. Retorque intake and exhaust manifold.
3. Check engine compression.
4. Check valve clearance.

## EXHAUST MANIFOLD PROCEDURE

1. If necessary, clean gasket surfaces on exhaust manifold and cylinder head.
2. Install exhaust manifold and exhaust manifold gasket.
3. Install fasteners.

### NOTE:

Exhaust manifold fasteners must be tightened in two stages.

4. Tighten fasteners to 20-30 N-m (15-22 lb-ft) during the first stage.
5. Retighten fasteners to 60-80 N-m (44-59 lb-ft) during the second stage.

## INTAKE MANIFOLD PROCEDURE

1. Clean and inspect the mounting surfaces of the intake manifold and the cylinder head. Both surfaces must be clean and flat (Figure 10.1).
2. Clean and lightly oil the manifold bolt/stud threads.
3. Install a new lower intake manifold gasket.
4. Position the lower intake manifold to the cylinder head.
5. Install retaining bolts/studs finger tight.
6. Tighten all bolts/studs to specifications in the tightening sequence shown:
  - First pass = 7 = 10 N-m (5-7 lb-ft).
  - Final pass = 26-38 N-m (19-28 lb-ft).

Figure 10.1 — Intake Manifold Installation

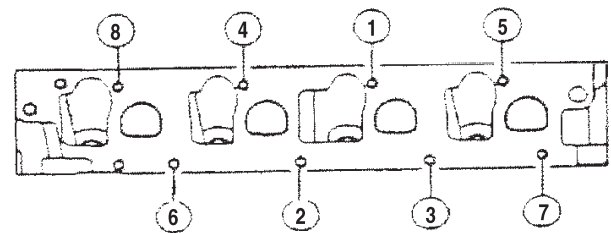

FASTENER TORQUE SEQUENCE

FPP00283

## CYLINDER HEAD PROCEDURE

1. Position head gasket on the block (Figure 10.2).
2. Position cylinder head to cylinder block.
3. Install 10 cylinder head bolts in numerical sequence. Tighten to 70 N-m (52 lb-ft) in sequence. Retighten to 70 N-m (52 lb-ft) in sequence. Then turn all head bolts an additional 90 - 100 degrees in sequence.



EV

...ille  
...or  
...with a  
...e again.  
...FUL and ADD  
...LAB

...the Maintenance S  
...is low add dis-  
...rs. DO NOT USE  
...COOLANT  
...coolant m  
...ure as neces  
...ing proper  
...adiator filler  
...sk.  
...sket in radiate  
...necessary. To ha  
...an Authorized Se  
...ce  
...system and coolant re



## MAINTENANCE OWNER/ OPERATOR CAN PERFORM

### ◆ CHECK ENGINE OIL LEVEL

Refer to “Checking Fluid Levels”.

### ◆ CHECK BATTERY

- See “Checking Fluid Levels”.
- Check battery cables for condition, tightness, corrosion or damage. Clean, tighten or replace as necessary.

### ◆ EXERCISE SYSTEM

Start the generator engine at least once every seven days and let it run at least 20 minutes. See “Weekly Exercise Cycle”.

### ◆ INSPECT COOLING SYSTEM

- Inspect engine cooling system. See “Maintenance Schedule”.
- Check hoses for damage, deterioration, leaks, etc. Correct any discrepancies found.
- Check hose clamps for tightness.

### ◆ CHECK ENGINE COOLANT LEVEL

See “Checking Fluid Levels”.

### ◆ PERFORM VISUAL INSPECTION

Complete a thorough visual inspection of the entire engine-generator monthly. Look for obvious damage, loose, missing or corroded nuts, bolts and other fasteners. Look for fuel, oil or coolant leaks.

### ◆ INSPECT EXHAUST SYSTEM

Inspect the exhaust system at least once every three months. Check all exhaust system pipes, mufflers, clamps, etc. for condition, tightness, leaks, security, damage.

### ◆ CHECK FAN BELT

- Inspect fan belts every three months. Replace any damaged, deteriorated, worn or otherwise defective belt.
- Check fan belt tension. Thumb pressure, exerted midway between pulleys, should deflect about 3/8 to 5/8 of an inch. Adjust belt tension as required.

### ◆ INSPECT ENGINE GOVERNOR

Visually inspect electronic governor.

## —▲ DANGER ▲—

- ▲ Do not attempt to adjust the governor. Only qualified service facilities should adjust the governor. Excessively high operating speeds are dangerous and increase the risk of personal injury. Low speeds impose a heavy load on the engine when adequate engine power is not available and may shorten engine life. Correct rated frequency and voltage are supplied only at the proper governed speed. Some connected electrical load devices may be damaged by incorrect frequency and/or voltage. Only qualified service technicians should adjust the governed speed.

### ◆ CHANGING ENGINE OIL

Refer to maintenance performed by authorized service facilities for engine oil and filter change frequencies.

Drain the oil while the engine is still warm from running. This means warm up the engine, shut it down and drain immediately as follows:

1. Remove OIL DRAIN HOSE from its retaining clip.
2. Loosen and remove OIL DRAIN HOSE CAP. Drain oil completely into suitable container.
3. When all oil has drained, install and tighten OIL DRAIN HOSE CAP, and re-install into its retaining clip.
4. Turn OIL FILTER (Figure 10.3) counterclockwise and remove. Properly dispose of old filter.
5. Apply light coating of new engine oil to seal of new oil filter. Install FILTER and tighten by hand only. DO NOT OVER TIGHTEN.
6. Remove OIL FILL CAP. Add recommended oil (see SPECIFICATIONS). DO NOT FILL ABOVE THE DIPSTICK “FULL” MARK. Crankcase oil capacity is 4.0 U.S. quarts (3.8 liters).

## —▲ CAUTION ▲—

- ▲ After refilling the crankcase with oil, always check oil level on dipstick. NEVER OPERATE ENGINE WITH OIL BELOW THE DIPSTICK “ADD” MARK.
7. Start engine and check for oil leaks.

### ◆ CHANGING THE ENGINE AIR CLEANER

To replace the engine air cleaner, (part number 059402), simply remove the air cleaner cover and replace the air filter making sure it is positioned properly before reattaching the cover (Figure 10.3).

See the “Service Schedule,” for air cleaner maintenance.



### ◆ SPARK PLUGS

Reset the spark plug gap or replace the spark plugs as necessary (Figure 10.4).

1. Clean the area around the base of the spark plugs to keep dirt and debris out of the engine. Clean by scraping or washing using a wire brush and commercial solvent. Do not blast the spark plugs to clean.
2. Remove the spark plugs and check the condition. Replace the spark plugs if worn or if reuse is questionable. See the "Service Schedule," Section 6, for recommended inspection.
3. Check the spark plug gap using a wire feeler gauge. Adjust the gap to 1.07-1.17 mm (0.042-0.046 inch) by carefully bending the ground electrode (Figure 10.4).

*Figure 10.4 – Setting the Spark Plug Gap*

SET PLUG GAP AT 1.07 - 1.17 mm  
(0.042 - 0.046 inch)

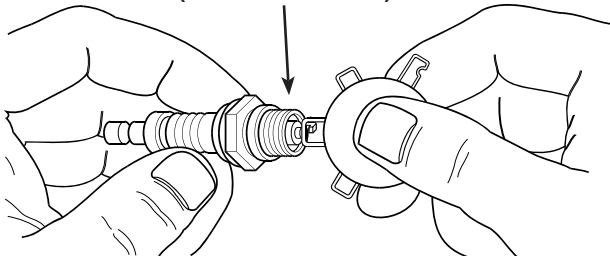

### ◆ COOLANT CHANGE

Every year, have an Authorized Service Facility drain, flush and refill the cooling system. See "Specifications" for cooling system recommendations.

## MISCELLANEOUS MAINTENANCE

### ◆ CLEANING THE GENERATOR

Keep the generator as clean and as dry as possible. Dirt and moisture that accumulates on internal generator windings have an adverse effect on insulation resistance.

Periodically clean generator exterior surfaces. A soft brush may be used to loosen caked on dirt. Use a vacuum system or dry, low pressure air to remove any accumulations of dirt. The generator is housed inside an all-weather enclosure, clean the enclosure with a soft, damp cloth or sponge and water.

Once each year have the generator cleaned and inspected by an Authorized Service Dealer. That dealer will use dry, low pressure air to clean internal windings. Parts inside the control console should be cleaned and inspected at this time as well.

Finally, have the insulation resistance of stator and rotor windings checked. If insulation resistances are excessively low, the generator may require drying.

### ◆ BATTERY

All lead-acid storage batteries discharge when not in use. Refer to specific instructions and warnings that accompany the battery. If such information is not available, observe the following precautions when handling a battery:

- DO NOT use jumper cables and a booster battery to crank or start the generator engine.
- DO NOT recharge a weak battery while it is installed in the generator. Remove battery from generator and recharge in a well-ventilated area, away from fuel vapors, sparks, heat or flames.
- Battery electrolyte fluid is an extremely caustic sulfuric solution that can cause severe burns. DO NOT permit fluid to contact eyes, skin, clothing, painted surfaces, wiring insulation, etc. If any battery fluid is spilled, flush the affected area with clear water immediately.
- Always wear safety glasses, rubber apron and gloves when handling a battery.
- Batteries give off explosive hydrogen gas while charging. The gas can form an explosive mixture around the battery for several hours after charging. Any spark, heat or flames can ignite the gas and cause an explosion which can shatter the battery, causing blindness or other serious injury.

### ◆ BATTERY MAINTENANCE

The battery should be inspected per Section 4.7, Scheduled Maintenance. The following procedure should be followed for inspection:

1. Inspect the battery posts and cables for tightness and corrosion. Tighten and clean as necessary.
2. Check the battery fluid level of unsealed batteries and, if necessary, fill with DISTILLED WATER ONLY. DO NOT USE TAP WATER IN BATTERIES.
3. Have the state of charge and condition checked. This should be done with an automotive-type battery hydrometer.

—▲ **DANGER** ▲—

- ▲ Storage batteries give off explosive hydrogen gas. This gas can form an explosive mixture around the battery for several hours after charging. The slightest spark can ignite the gas and cause an explosion. Such an explosion can shatter the battery and cause blindness or other injury. Any area that houses a storage battery must be properly ventilated. Do not allow smoking, open flame, sparks or any spark producing tools or equipment near the battery.

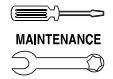

# Standby Generator Sets Maintenance



- ⚠ Battery electrolyte fluid is an extremely corrosive sulfuric acid solution that can cause severe burns. Do not permit fluid to contact eyes, skin, clothing, painted surfaces, etc. Wear protective goggles, protective clothing and gloves when handling a battery. If fluid is spilled, flush the affected area immediately with clear water.
- ⚠ Do not use any jumper cables or booster battery to crank and start the generator engine. If the battery has completely discharged, remove it from the generator for recharging.

## ⚠ WARNING ⚠

- ⚠ Be sure the AUTO/OFF/MANUAL switch is set to the OFF position, before connecting the battery cables. If the switch is set to AUTO or MANUAL, the generator can crank and start as soon as the battery cables are connected.
- ⚠ Be sure the 120VAC power supply to the battery is turned OFF, or sparking may occur at the battery posts as the cables are attached and cause an explosion.

### ◆ BATTERY REPLACEMENT

When replacing batteries, use the same number and the type of battery that follows:

BCI Group No.	CCA
26	525 @ 0 deg. F

#### NOTE:

**The BCI number should be located directly on the battery.**

### ◆ PERIODIC REPLACEMENT PARTS

Part Name	Part Number
Oil Filter	Motorcraft FL-400-S (supplied with engine)
Radiator Cap	# 046627
Air Cleaner	# 059402
Spark Plug	Motorcraft AWSF-52-C (supplied with engine)
Battery	# 077483



## Standby Generator Sets Service Schedule



### SERVICE SCHEDULE

The following is a recommended maintenance schedule for small standby and residential generator sets. The established intervals in the schedule are the *maximum* recommended when the unit is used in an average service application. They will need to be decreased (performed more frequently) if the unit is used in a severe application. Use calendar time or accumulated run time, from the previous maintenance interval to determine the next required maintenance interval.

#### Service Maintenance Interval Information:

The various service maintenance intervals are designated by interval numbers as follows:

- 1 An early inspection of the generator set to insure it is ready to operate when required and to identify any potential problem areas.

*Performed monthly this requires approximately .5 man-hours per unit to complete.*

*This inspection may be performed by the end user providing the following safety steps are taken to prevent the engine from starting automatically without warning:*

**To prevent injury, perform the following steps in the order indicated before starting any maintenance:**

- Disable the generator set from starting and/or connecting to the load by setting the control panel AUTO/OFF/MANUAL switch to the OFF position.
- Remove the 5 amp and 15 amp control panel fuses.
- Turn off the battery charger (turn OFF utility supply to ATS).
- Remove the negative battery cable.

**The battery charger must be turned off BEFORE removing the battery cable to prevent an over current condition from burning out sensitive control panel components and circuits.**

**Following all maintenance, reverse these steps to insure the unit is returned to standby setup for normal operation when required.**

- 2 A break-in service inspection of the generator set to insure it is ready to operate and carry the load when required, and to identify any potential problem areas.

*Performed **ONLY ONCE** following the first three months, or 30 run time hours of operation after purchase of the unit and requires approximately 2.5 man-hours per unit to complete.*

*This inspection contains some maintenance tasks which require special tools, equipment, and/or knowledge to accomplish and should be performed only by an Authorized Service Dealer.*

- 3 An operational inspection of the generator set to insure it is ready to operate and carry the load when required, and to identify any potential problem areas.

*Performed semi-annually this requires approximately 1.5 man-hours per unit to complete.*

*This inspection contains some maintenance tasks which require special tools, equipment, and/or knowledge to accomplish and should be performed only by an Authorized Service Dealer.*

- 4 A mid-level inspection of the generator set to insure it is ready to operate and carry the load when required, and to identify any potential problem areas.

*Performed annually this requires approximately 4.0 man-hours per unit to complete.*

*This inspection contains some maintenance tasks which require special tools, equipment, and/or knowledge to accomplish and should be performed only by an Authorized Service Dealer.*



## Standby Generator Sets Service Schedule



Maintenance Tasks	Level 1	Task Comp. (Date-Initials)	Level 2	Task Comp. (Date-Initials)	Level 3	Task Comp. (Date-Initials)	Level 4	Task Comp. (Date-Initials)
	Recommended to be done monthly 10 Hrs.		Required to be done 3 months/ Break-in 30 Hrs.		Required to be done Semi-annually 50 Hrs.		Required to be done Annually 100 Hrs.	
1. Disable the unit from operating per the first page warning.	○		○		○		○	
2. Check the engine oil level. Adjust as necessary.	○		○		○		○	
3. Check the engine coolant level. Adjust as necessary.	○		○		○		○	
4. Check the engine coolant thermal protection level. Correct as necessary.							○	
5. Check the natural gas delivery system on gas engine driven units. Tighten connections as necessary.			○		○		○	
6. Check the air inlets and outlets for debris. Clean as necessary.	○		○		○		○	
7. Check the battery electrolyte level if accessible. Adjust as necessary.	○		○		○		○	
8. Check the battery posts, cables, and charger for loose connections, corrosion, and proper operation. Correct as necessary.	○		○		○		○	
9. Check the unit wiring for loose connections, corrosion, and damage. Correct as necessary.							○	
10. Check the engine accessory drive belts for wear, weather cracking, and damage. Replace as necessary.							○	
11. Visually inspect the unit looking for leaks, wear or damage, loose connections or components, and corrosion. Correct as necessary.	○		○		○		○	
12. Test the engine and transfer switch safety devices. Correct and/or adjust as necessary.							○	

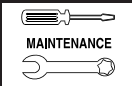

## Standby Generator Sets Service Schedule

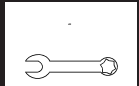

Maintenance Tasks	Level 1	Level 2	Level 3	Level 4
	Recommended to be done monthly 10 Hrs.	Task Comp. (Date-Initials) Required to be done 3 months/ Break-in 30 Hrs.	Task Comp. (Date-Initials) Required to be done Semi-annually 50 Hrs.	Task Comp. (Date-Initials) Required to be done Annually 100 Hrs.
13. Initiate an automatic start and transfer of the unit to site load and exercise it for at least 1 hour looking for leaks, loose connections or components, and abnormal operating conditions. Correct as necessary.				
14. Start and exercise the unit at full rated load (use a load bank if the site load is not enough) for at least 2 hours looking for leaks, loose connections or components, and abnormal operating conditions. Correct as necessary.				
15. Change the engine oil.				
16. Replace the engine oil filter(s).				
17. Replace the engine air filter(s).				
18. Replace the engine fuel filter(s) on diesel engine driven units and re-prime the fuel system.				
19. Check the engine spark plugs on gas engine driven units. Clean and re-gap or replace as necessary.				
20. Perform a 5 minute no-load operational run of the unit looking for any post service problems.				
21. Return the unit to standby setup for operation when required.				



## TROUBLESHOOTING GUIDE

PROBLEM	CAUSE	CORRECTION
Engine won't crank.	<ol style="list-style-type: none"> <li>15 amp fuse blown.</li> <li>Loose or corroded or defective battery cables.</li> <li>Defective starter contactor.</li> <li>Defective starter motor.</li> <li>Dead or Defective Battery.</li> <li>5 amp fuse blown.</li> </ol>	<ol style="list-style-type: none"> <li>Replace fuse.</li> <li>Tighten, clean or replace battery cables as necessary.</li> <li>Replace contactor.*</li> <li>Replace starter motor.*</li> <li>Remove, change or replace battery.</li> <li>Replace fuse.*</li> </ol>
Engine cranks but won't start	<ol style="list-style-type: none"> <li>Out of fuel.</li> <li>Fuel solenoid (FS) is defective</li> <li>Open Wire #14A from Engine Control circuit board.</li> <li>Spark plugs defective.</li> <li>Door on tank not closed.</li> </ol>	<ol style="list-style-type: none"> <li>Replenish fuel.</li> <li>Replace solenoid.*</li> <li>Reconnect wire.</li> <li>Clean, regap or replace plugs.</li> <li>Close door on tank.</li> </ol>
Engine starts hard, runs rough.	<ol style="list-style-type: none"> <li>Flame arrestor (air cleaner) plugged or damaged.</li> <li>Plugged fuel line.</li> <li>Defective spark plugs.</li> <li>Fuel pressure incorrect.</li> </ol>	<ol style="list-style-type: none"> <li>Clean or replace as needed.</li> <li>Unclog fuel line.</li> <li>Clean, regap or replace plugs.</li> <li>Confirm fuel pressure to regulator is as recommended in SPECIFICATIONS.</li> </ol>
Engine starts then shuts down.	<ol style="list-style-type: none"> <li>Engine oil level is low.</li> <li>Engine is overheated.</li> <li>Defective Low Oil Pressure Switch</li> <li>Defective Coolant Temperature Switch</li> <li>Defective Control Module circuit board.</li> <li>Coolant Level is Low.</li> <li>Defective Low Coolant Level Switch</li> </ol>	<ol style="list-style-type: none"> <li>Check oil and add oil as needed.</li> <li>Check cooling system for leaks.</li> <li>Replace switch.*</li> <li>Replace switch.*</li> <li>Replace board.*</li> <li>Repair leak - Add coolant.</li> <li>Replace Switch.*</li> </ol>
AUTO/OFF/MANUAL Switch at OFF, engine continues to run	<ol style="list-style-type: none"> <li>Defective AUTO/OFF/MANUAL switch</li> <li>Open/disconnected wire #15A between AUTO/OFF/MANUAL switch and Control Module circuit board.</li> <li>Defective Control Module circuit board</li> </ol>	<ol style="list-style-type: none"> <li>Replace switch.*</li> <li>Reconnect/close wire.</li> <li>Replace board.*</li> </ol>
No output from generator.	<ol style="list-style-type: none"> <li>Check main line circuit breaker.</li> <li>Check circuit breaker &amp; fuses.</li> <li>Transfer switch set to NORMAL position</li> <li>Generator internal failure.</li> <li>Thermal circuit breaker open.</li> </ol>	<ol style="list-style-type: none"> <li>Reset to ON or CLOSED.</li> <li>Reset and replace, if necessary.</li> <li>Set to GENERATOR position.</li> <li>*</li> <li>Auto-reset - Wait 5 min. and attempt restart.</li> </ol>

**\*Contact the nearest Authorized Dealer for assistance.**





11/2/05

DATE: 11/2/05

EXPLODED VIEW: CONNECTION BOX SPL PARTS  
 DRAWING #: 0F7352

GROUP A

APPLICABLE TO:

ITEM	PART #	QTY	DESCRIPTION
1	0F7135	1	BREAKER TRAY B
2	0F7022	1	SUPPORT CONTR
3	0F7021	1	SUPPORT CONTR
4	0F7260	1	COVER CIRCUIT B
	0F7136	1	COVER CIRCUIT B
5	0F6156	1	PLATE WIRE SNG
6	0F4464	1	DECAL CUST CO
7	0D4698	REF	BLOCK TERM 20A
8	0F3824	1	DECAL UTIL SENS
9	057701	REF	BLOCK TERM 20A
10	0F6146	1	HANG TAG 2 WIR
12	081008	1	GROMMET 1.25 X
13	0C2267	2	SCREW HHTT M5
14	049226	2	WASHER LOCK M
15	051713	2	WASHER FLAT M
16	0C2212	11	SCREW PHTT M4
17	022264	11	WASHER LOCK #
18	0F6366A	1	XFMR DUAL 104V (SE)
	0F6366B	1	XFMR DUAL 120V (SE)
19	022241	1	NUT HEX 3/8-16 S
20	022237	1	WASHER LOCK 3
21	057329	1	LUG SLDLSS 350
22	057073	1	JUNCTION BLOCK
23	023484J	1	BUSHING SNAP S
24	0E3257	15	SCREW HWHTF M
25	0E7890	REF	BRKT CB MTG BA
	0E6002	REF	MTG TRACK BQ S
26	0D5544	REF	CB 0100A 2P 240V
	062812	REF	CB 0080A 3P 240V
	0A2077	REF	CB 0125A 2P 240V
	040532	REF	CB 0100A 3P 240V
27	052619	REF	SCREW HHC M5-0
28	023897	REF	WASHER FLAT #1
29	049226	REF	WASHER LOCK M
30	051716	REF	NUT HEX M5-0.8
31	025433	1	LUG SLDLSS #6-1
32 *	0A1354A	REF	REGULATOR - DO
33 *	042568	REF	SCREW HHC M6-1
34 *	022473	REF	WASHER FLAT 1/
35 *	022097	REF	WASHER LOCK M
36 *	049813	REF	NUT HEX M6 X 1.0
37 *	0F7194	REF	BRACKET PANEL SUP
38	057593	1	CABLE TIE MOUNT B
39	0F1733	1	DECAL CUSTOMER C

\* USED ON 1.5L ONLY.

GROUP A

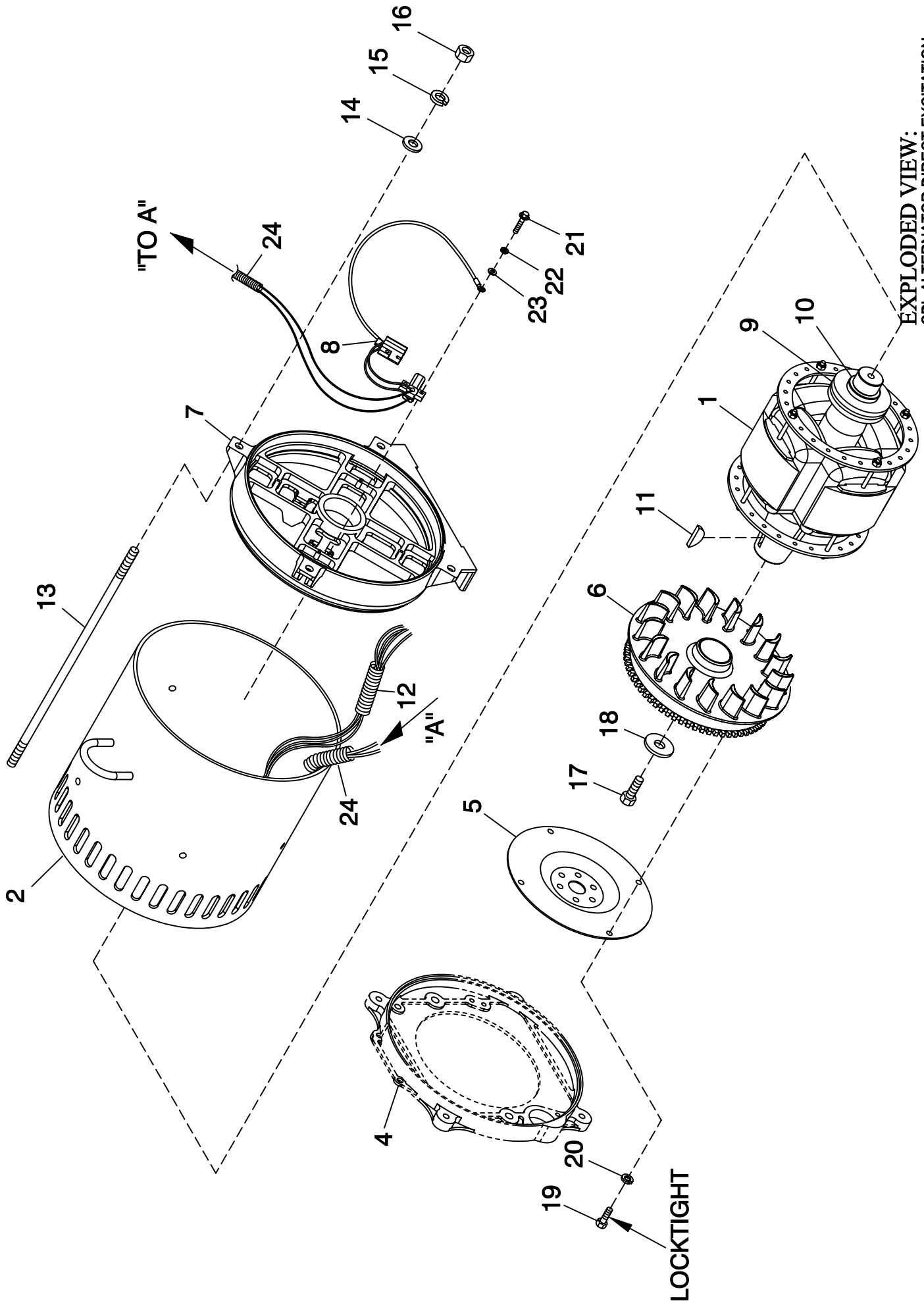



# GROUP C

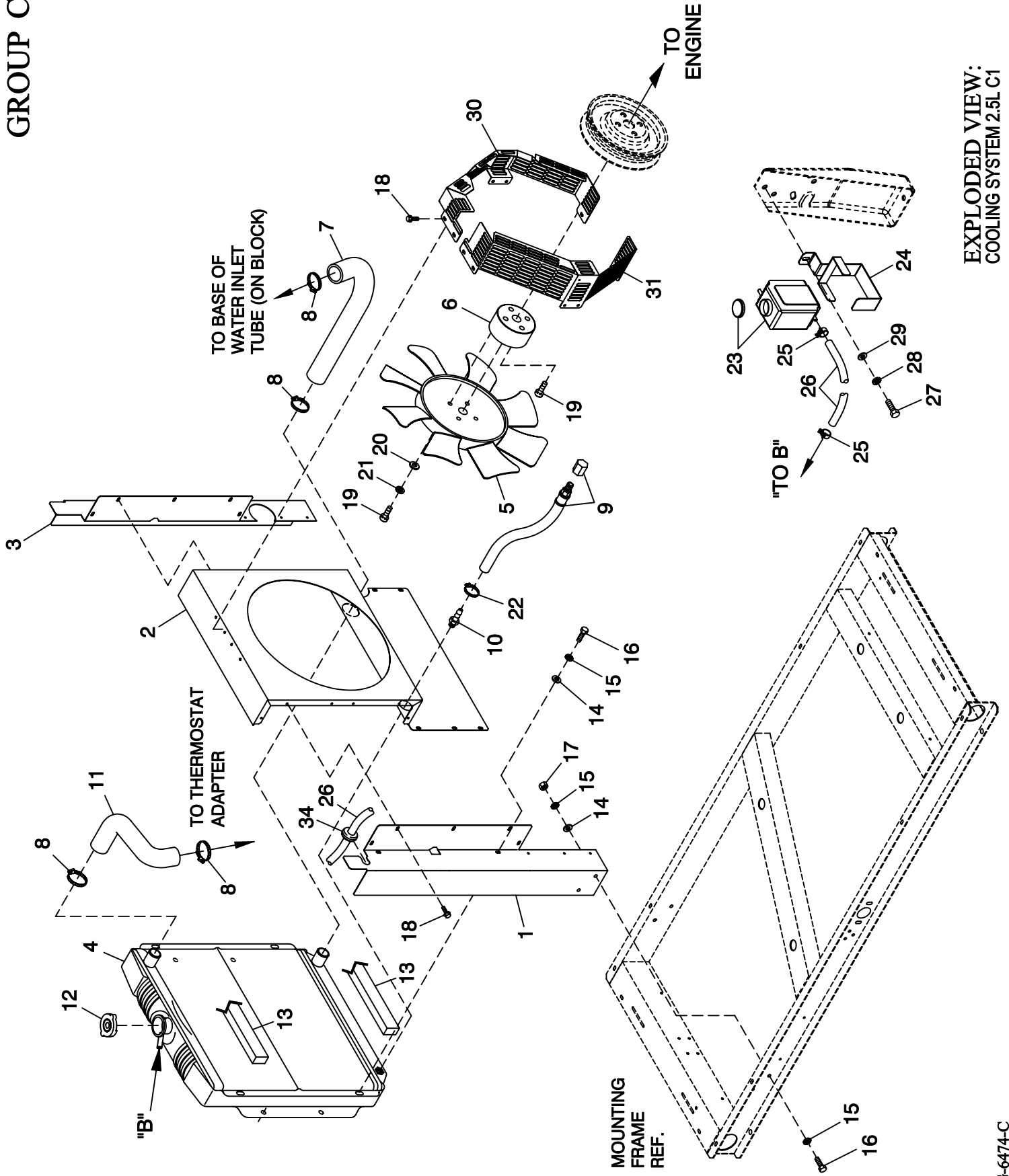

EXPLODED VIEW:  
 COOLING SYSTEM 2.5L C1  
 DRAWING #: 0F7363

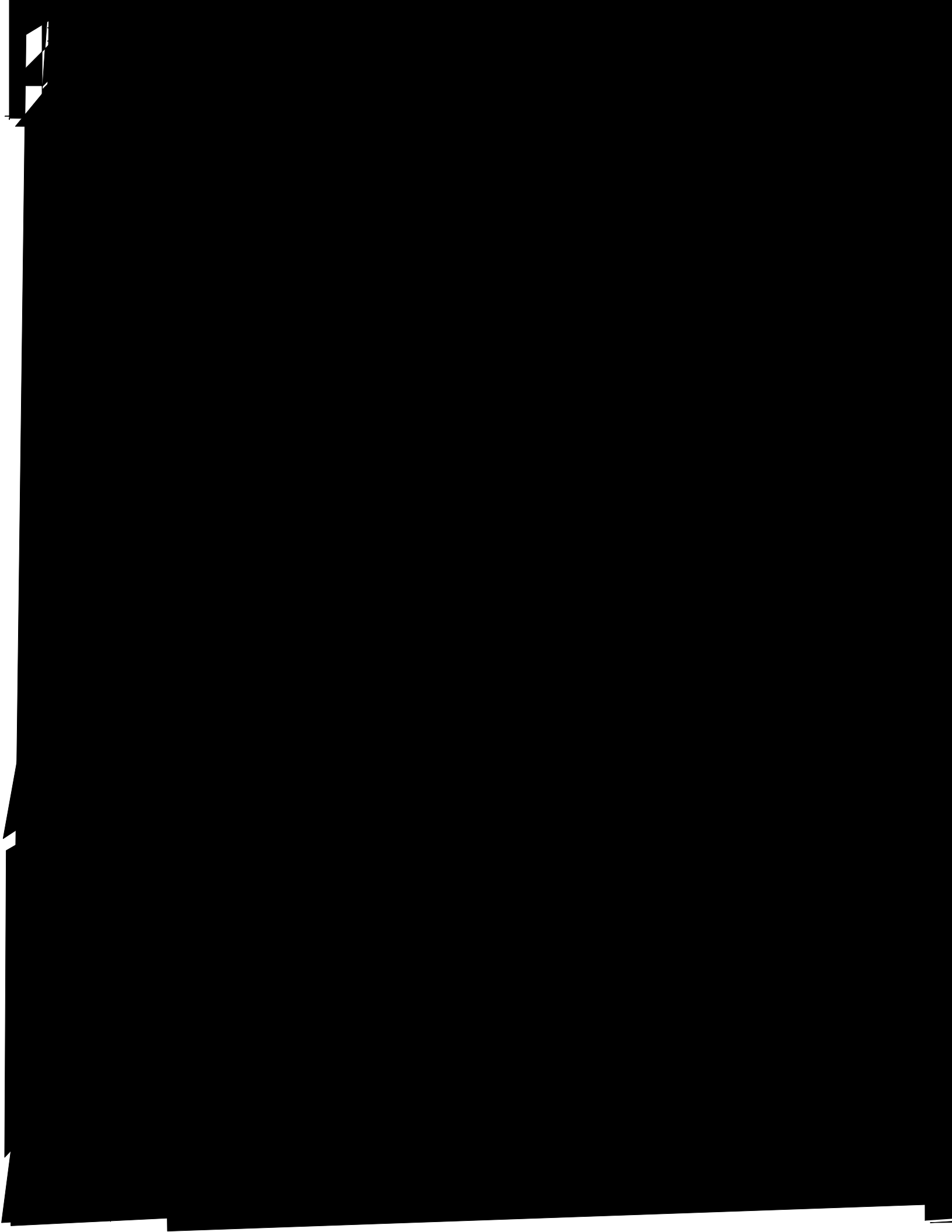

GROUP C

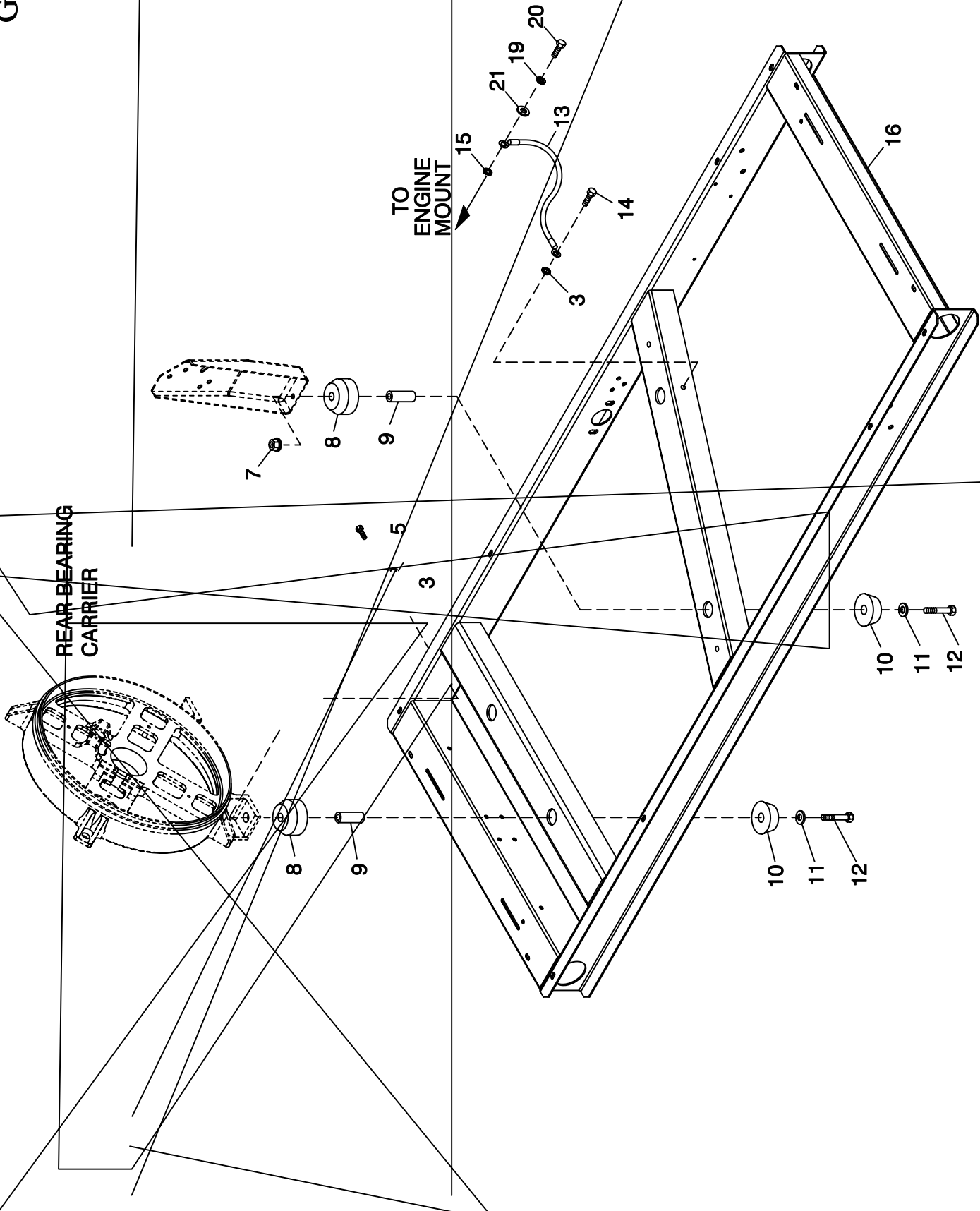

REAR BEARING  
CARRIER

TO ENGINE  
MOUNT

EXPLODED VIEW:  
MOUNTING BASE 2.5L FORD  
DRAWING #: 0F7416

REVISION: G-6148-A  
DATE: 8/10/05



**EXPLODED VIEW: MOUNTING BASE 2.5L FORD****DRAWING #: 0F7416****GROUP C****APPLICABLE TO:**

<b>ITEM</b>	<b>PART #</b>	<b>QTY.</b>	<b>DESCRIPTION</b>
1	049813	1	NUT HEX M6 X 1.0 G8 YEL CHR
2	022097	1	WASHER LOCK M6-1/4
3	026850	2	WASHER SHAKEPROOF EXT 1/4 STL
4	055414	1	LUG SLDLSS #2-#8 X 17/64 CU
5	022473	1	WASHER FLAT 1/4-M6 ZINC
6	047411	1	SCREW HHC M6-1.0 X 16 G8.8
7	052860	4	NUT FLANGED HEX M12-1.75
8	052251	4	DAMPENER VIBRATION 40 BLUE
9	052257	4	SPACER .49 X .62 X 1.87 PWDR/ZNC
10	052252	4	DAMPENER VIBRATION
11	052259	4	WASHER FLAT M12
12	052891	4	SCREW HHC M12-1.75 X 80 G8.8
13	0536210261	1	ASSY WIRE #0 12.00"
14	074906	1	SCREW HHTT M6-1.0 X 20 BP
15	025507	REF	WASHER SHAKEPROOF EXT 7/16 STL
16	0F6935	1	MTG BASE, 2.5L FORD C1 CPL
19	046526	REF	WASHER LOCK M10
20	049814	REF	SCREW HHC M10-1.5 X 25 G8.8
21	022131	REF	WASHER FLAT 3/8-M10 ZINC

GROUP C

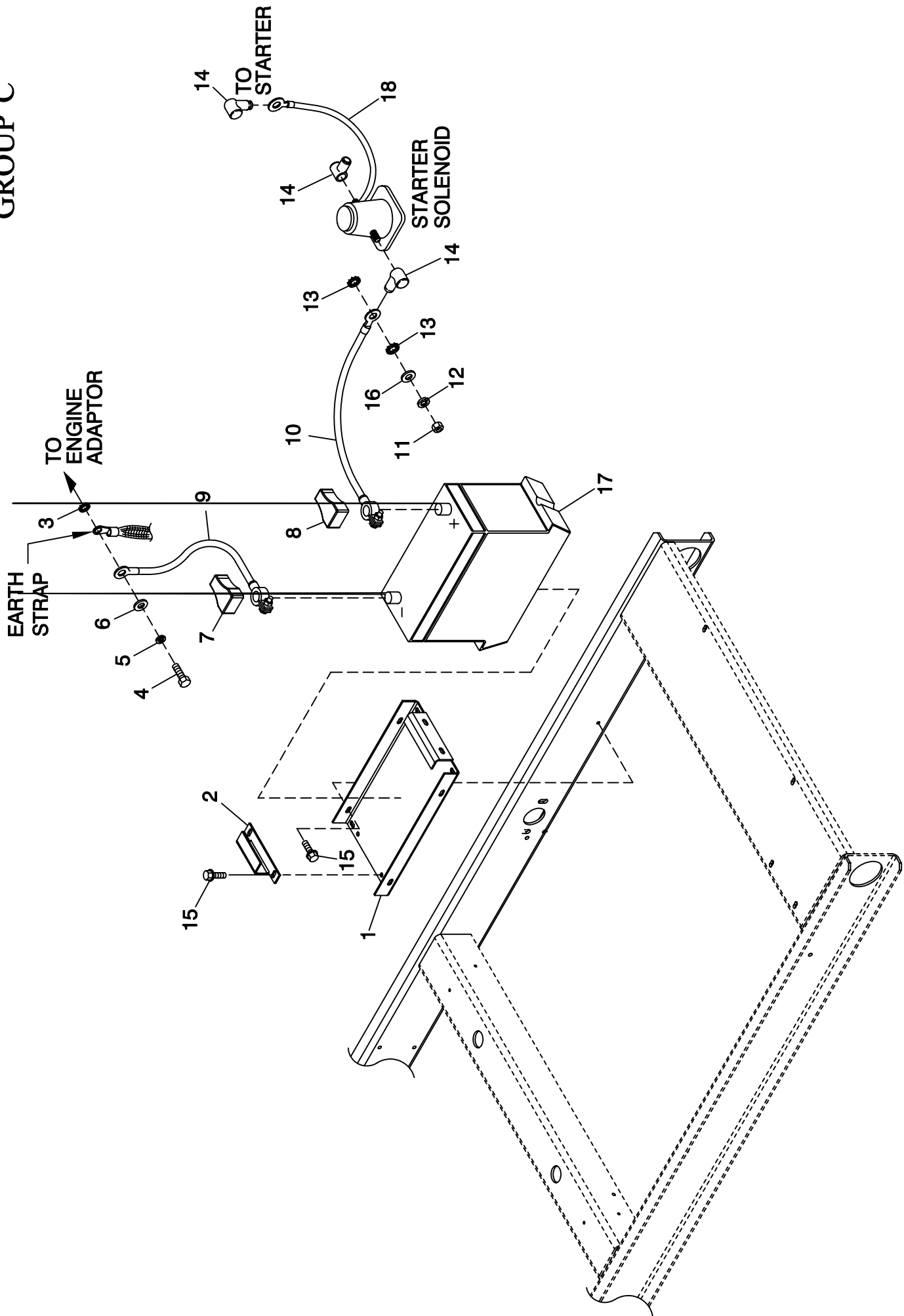

EXPLODED VIEW:  
BATTERY C1 CPL  
DRAWING #: 0F7422

REVISION: G-6517-D  
DATE: 9/23/05

**EXPLODED VIEW: BATTERY C1 CPL****DRAWING #: 0F7422****GROUP C****APPLICABLE TO:**

<b>ITEM</b>	<b>PART #</b>	<b>QTY.</b>	<b>DESCRIPTION</b>
1	0F3408B	1	BATTERY TRAY C1 CPL
2	0F3411	1	STRAP BATTERY RETAINMENT
3	025507	REF	WASHER SHAKEPROOF EXT 7/16 STL
4	052647	REF	SCREW SHC M10-1.5 X 25 G12.9
5	046526	REF	WASHER LOCK M10
6	022131	REF	WASHER FLAT 3/8-M10 ZINC
7	050331A	REF	BATT POST COVER RED +
8	050331	REF	BATT POST COVER BLK -
9	038805J	1	CABLE BATTERY BLK #1 X 30.00
10	038804U	1	CABLE BATTERY RED #1 X 28.00
11	045771	REF	NUT HEX M8-1.25 G8 YEL CHR
12	022129	REF	WASHER LOCK M8-5/16
13	027482	REF	WASHER SHAKEPROOF EXT 5/16 STL
14	0F3976	3	BOOT CONTACTOR CABLES
15	0C2454	4	SCREW THF M6-1 X 16 N WA ZJJS
16	022145	REF	WASHER FLAT 5/16-M8 ZINC
17	077483	REF	BATTERY 12VDC 75-AH 26
18	0742600131	1	ASSY WIRE #16 RED 1.6

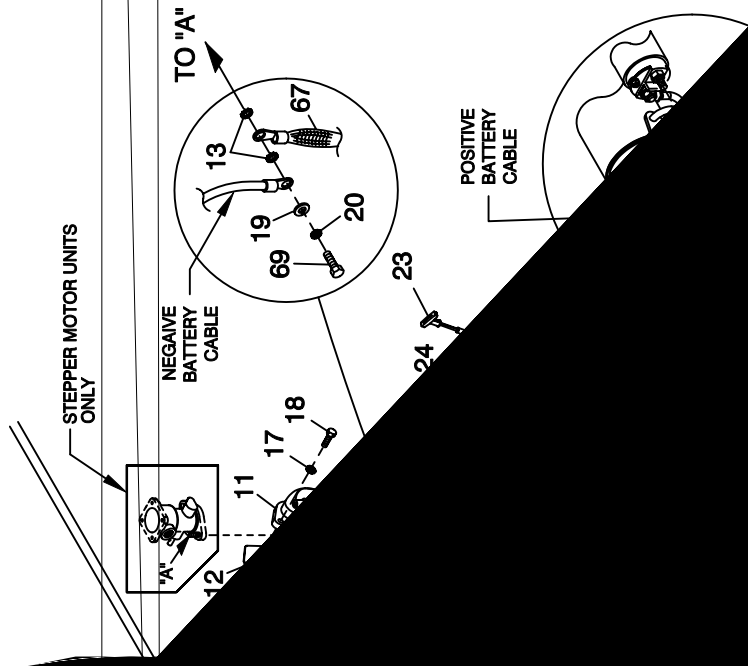

EXPLODED VIEW  
 DRAWING #: 0F  
 APPLICABLE TO:

ITEM	PART #	QTY.	DESCRIPTION	ITEM	PART #	QTY.	DESCRIPTION
1	0E9909	REF	ENGINE 2.5L FORD	16	022097	7	WASHER LOCK M6-1/4
2	0E9739	1	PULLEY 2.5L FORD WATER PUMP	17	022129	10	WASHER LOCK M8-5/16
3	049814	7	SCREW HHC M10-1.5 X 25 G8.8	18	043107	10	SCREW HHC M8-1.25 X 25 G8.8
5	0D3488B	1	SERPENTINE BELT - 40.85" LENGTH	19	022131	13	WASHER FLAT 3/8-M10 ZINC
6	0A8584	1	SWITCH OIL PRESSURE 10PSI 2POL	20	046526	23	WASHER LOCK M10
7	0E0561	1	ASSY WATER LEVEL SENSOR C/E PL	21	052625	2	SCREW SHC M10-1.5 X 35 G12.9
8	0A6751	1	SW-TMP 245 DEG 3/8 NPT	22	0E9708	2	ENGINE FOOT 2.5L FORD
9	035579	1	BUSHING REDUCER 1/4 TO 1/8	23	0E9738	1	DIPSTICK 2.5L FORD
10	026925	1	PLUG STD PIPE 3/8 STEEL SQ HD	24	0E9929	1	BRACKET DIPSTICK TUBE
11	0E9611	1	MANIFOLD INTAKE (MACHINED) (STEPPER MOTOR)	25	042568	1	SCREW HHC M6-1.0 X 20 G8.8
12	0E9681	1	GASKET 2.5L FORD INTAKE MAN.	26	0F7428	1	HARNNESS ENGINE 2.5L R-100 CPL (NOT SHOWN)
13	025507	3	WASHER SHAKEPROOF EXT 7/16 STL	27	0D5417	6	SCREW HHC M10-1.0 X 25 G10.9
14	077043A	1	CONDUIT FLEX .38" ID (6" LG)	28	0F3903B	1	FLEX PLATE 2 POLE 2.5L FORD
15	022145	2	WASHER FLAT 5/16-M8 ZINC	29	0E9655	1	ADAPT CASTING MACH 2.5L FORD
				30	057192	4	SCREW SHC M10-1.5 X 30 G12.9
				31	060619	2	SCREW SHC M10-1.50 X 40 G12.9
				32	0E8940	1	SPACER FLEXPLATE HSB
				33	0E9680	1	GASKET 2.5L FORD EXHAUST MAN.
				34	0E9609	1	MANIFOLD EXHAUST (MACHINED)
				35	0E9930	1	HEAT SHIELD EXHAUST MANIFOLD
				36	049821	3	SCREW SHC M8-1.25 X 30 G12.9
				37	0E9747	1	STARTER 12 VOLT
				38	047411	4	SCREW HHC M6-1.0 X 16 G8.8
				39	022473	8	WASHER FLAT 1/4-M6 ZINC
				40	045772	2	NUT HEX M10-1.5 G8 YEL CHR
				41	064416	2	SCREW HHC M10-1.5 X 45 G8.8
				42	0F0252	1	SPRING BUSHING
				43	0E9868	1	ALTERNATOR D.C
				44	0F0035	1	BRKT D.C. ALTERNATOR (MACHINED)
				45	026082	1	SCREW HHC 3/8-16 X 2-1/4 G5
				46	0E9928	1	TENSIONER D.C. ALTERNATOR
				47	0F0383	1	HOSE 2.5L FORD COOLANT BY-PASS
				48	035473	2	CLAMP HOSE #12 .50-1.25
				49	0E9737	1	LOWER HOSE ADAPTER 2.5L FORD
				50	0F0393	1	O-RING 1-3/16 X 1-7/16 X 1/8
				51	045757	2	SCREW HHC M6-1.0 X 25 G8.8
				52	069860C	1	HOSE OIL DRAIN ASSY 21"
				53	048031J	1	HOSE CLAMP BAND 5/8"
				54	043790	1	BARBED EL 90 3/8 NPT X 3/8
				55	077456	1	ADAPTER M12-1.75 3/8 NPT
				56	052677	1	WASHER NYLON .50 X .87 X .06
				57	049813	1	NUT HEX M6 X 1.0 G8 YEL CHR
				58	0E9738A	1	DIPSTICK TUBE 2.5L FORD
				59	0F1132	1	COVER R/H SIDE ENGINE ADAPTOR
				60	0F1133	1	COVER L/H SIDE ENGINE ADAPTOR
				61 *	059355	8	SCREW SHC M10-1.50 X 50 G12.9
				62	085296	3	SCREW HHC 1/4-20 X 1/2 SS
				63	083896	3	WASHER LOCK 1/4-M6 SS
				64	084929	3	WASHER FLAT 1/4 SS
				65	027482	1	WASHER SHAKEPROOF EXT 5/16 STL
				66	045771	REF	NUT HEX M8-1.25 G8 CLEAR ZINC
				67	021991	1	EARTH STRAP
				68	022129	REF	WASHER LOCK M8-5/16
				69	052647	1	SCREW SHC M10-1.5 X 25 G12.9
				70	0F4604	REF	FILTER 2.5L FORD OIL

\* NOTE: TORQUE TO 44 FT/LBS.

# GROUP D

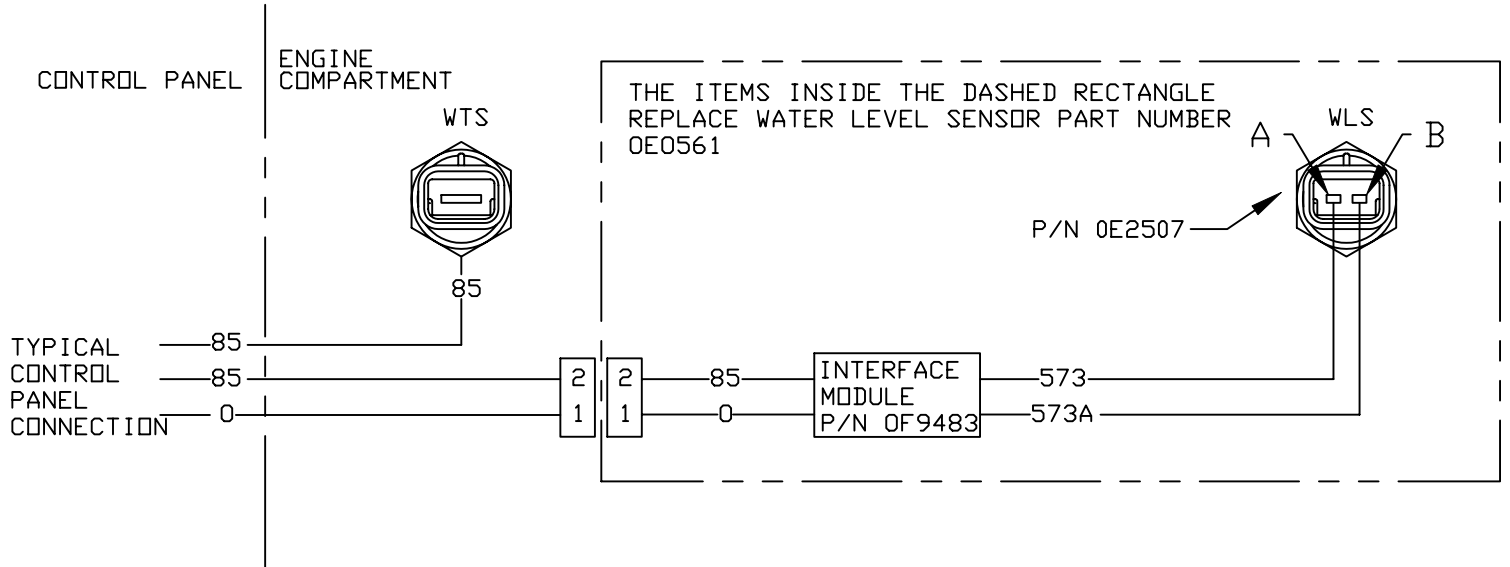

WIRING DIAGRAM FOR NEW COOLANT LEVEL SENSOR

## MECHANICAL DIAGRAM FOR NEW COOLANT LEVEL SENSOR INSTALATION

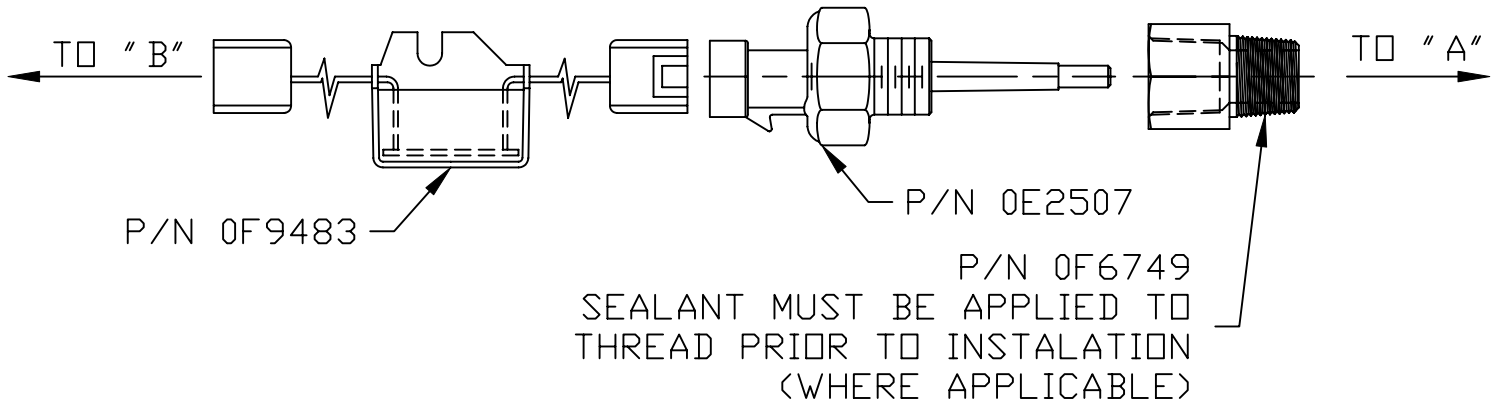

"A" = EXISTING COOLANT LEVEL SENSOR LOCATION ON UNIT  
 "B" = EXISTING COOLANT LEVEL SENSOR WIRE HARNESS CONNECTOR

# BLANK PAGE

**GROUP E**

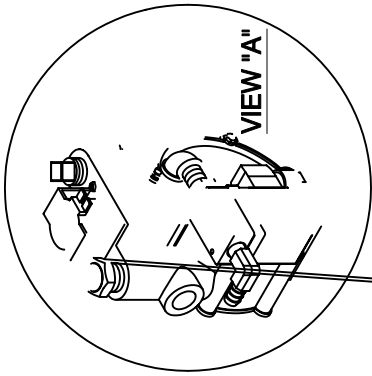

**IMPORTANT**

SOLENOID MUST BE  
INSTALLED WITH FLOW  
ARROW POINTING IN  
DIRECTION SHOWN IN  
ILLUSTRATION ABOVE.

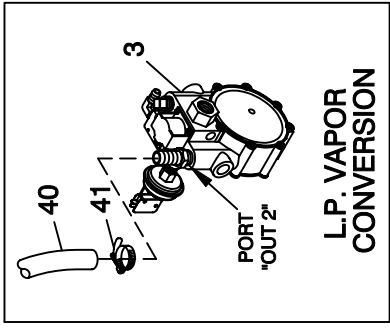

CARBURETOR ASSY.  
0E1028B (I/N 19)

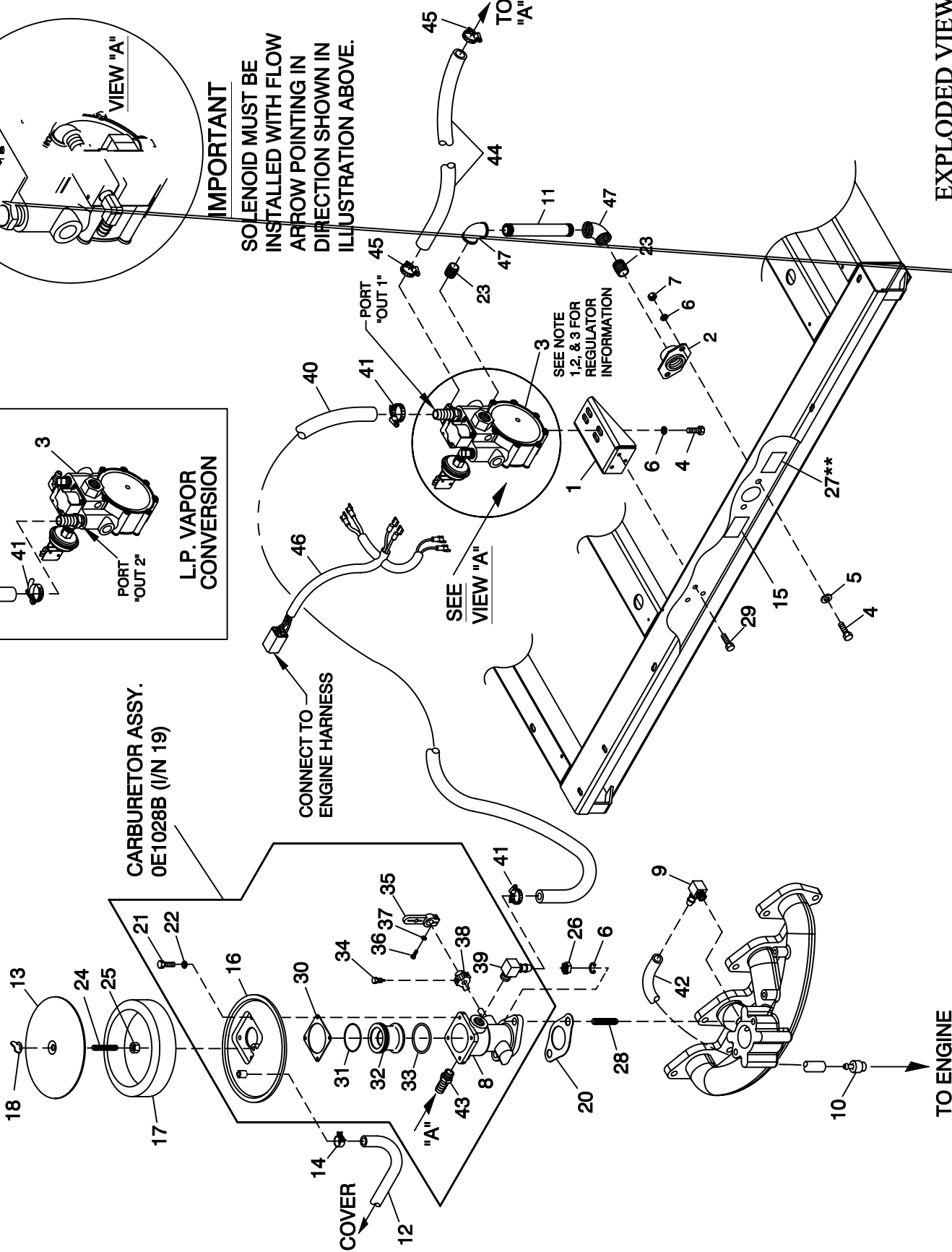

EXPLODED VIEW:  
NATURAL GAS FUEL OR LPV  
DRAWING #: 0F7440



EXPLODED VIEW:

DRAWING #:

APPLICABLE TO: 5L FORD

ITEM	PART
------	------



**EXPLODED VIEW: ENCLOSURE C1 CPL**

**DRAWING #: 0F7356**

**GROUP F**

**APPLICABLE TO:**

<b>ITEM</b>	<b>PART #</b>	<b>QTY.</b>	<b>DESCRIPTION</b>
1	0F7003 (XX)	1	ROOF C1 CPL
2	0F7004 (XX)	1	CORNER POST LH SIDE C1 CPL
3	0F7008 (XX)	1	DOOR REAR C1 CPL
4	0F7005 (XX)	1	CORNER POST RH SIDE C1 CPL
5	0F7007 (XX)	2	DOOR LH & RH SIDE C1 CPL
6	0F7006 (XX)	1	DUCT FRONT DISCHARGE C1 CPL
7	0C2634A	1	ASSEMBLY COVER ACCESS
8	0912970091	1	ASSY WIRE 14AWG 13.8" GRN/YEL
9	0912970090	2	ASSY WIRE 14AWG 33.5" GRN/YEL
10	0E5968	1	GASKET EXTRUDED TRIM (356" LG)
11	0E3257	6	SCREW HWHTF M6-1.0 X 16
12 **	077992	18	NUT HEX LOCK M6-1.0 SS NY INS
13	0F5049	3	TAB PULL
14	0F5048	3	LATCH VISE ACTION 5/16 HEX SKT
15	022473	1	WASHER FLAT 1/4-M6 ZINC
16	022097	1	WASHER LOCK M6-1/4
17	022127	1	NUT HEX 1/4-20 STEEL
18	0C2454	24	SCREW THF M6-1 X 16 N WA Z/JS
19	078115	20	WASHER SELF LOCKING DOME
20	0F3890B	2	RETAINER INSULATION (820)
21	0F3890	4	RETAINER INSULATION (450)
22	0F7365	2	INSULATION SIDE DOOR C1
23	0F7365B	1	INSULATION REAR DOOR C1 CPL
24	0F7365A	1	INSULATION ROOF C1 CPL

**OPTIONAL COMPARTMENT MATERIALS:**

ALL P/N'S WITH AN (XX) SUFFIX INDICATE A MULTIPLE MATERIAL AND COLOR OPTION.  
USE THE FOLLOWING LEGEND TO IDENTIFY THE CORRECT PART NUMBER:

<b>PART NO.</b>	<b>MATERIAL</b>	<b>COLOR</b>
0XXXXXSN	STEEL	TAN
0XXXXXAN	ALUMINUM	TAN
0XXXXXSG	STEEL	GRAY
0XXXXXAG	ALUMINUM	GRAY

\*\* ALUMINUM ENCLOSURE NOTE: ALL ENCLOSURE PANELS THAT FASTEN TO THE BASE FRAME MUST BE SECURED USING ITEM 18 & 11 THREAD FORMING FASTENER AND ITEM 12 LOCK NUT. LOCK NUT IS TO BE INSTALLED AFTER THREAD FORMING FASTENER HAS PENETRATED THROUGH EXTRUSIONS IN ENCLOSURE PANELS. ALL ROOF PANELS ARE TO BE SECURED IN THE SAME MANNER.

GROUP F

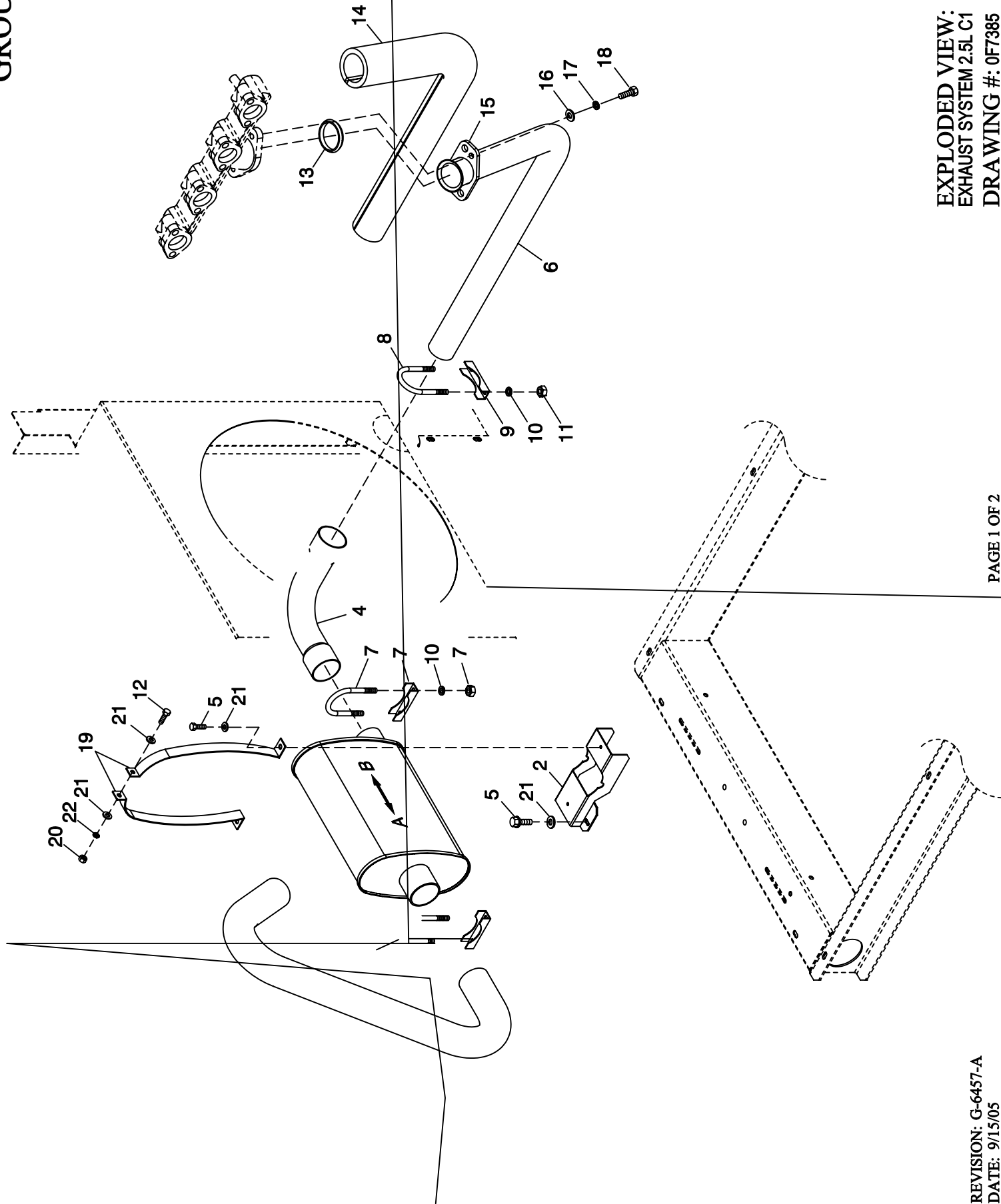

EXPLODED VIEW:  
EXHAUST SYSTEM 2.5L C1  
DRAWING #: 0F7385

REVISION: G-6457-A  
DATE: 9/15/05

**EXPLODED VIEW: EXHAUST SYSTEM 2.5L C1****DRAWING #: 0F7385****GROUP F****APPLICABLE TO:**

<b>ITEM</b>	<b>PART #</b>	<b>QTY.</b>	<b>DESCRIPTION</b>
1	0F7366	1	MUFFLER C1
2	0F7647	1	MUFFLER SADDLE
3	0F8095	1	PIPE EXHAUST OUTLET
4	0F7172	1	PIPE EXH INLET MFLR SIDE 2.5L
5	0E3257	4	SCREW HWHTF M6-1.0 X 16
6	0F7382	1	PIPE EXH INLET MANIFLD SIDE 2.5
7	0C6119	1	BOLT U 5/16-18 X 2-1/4
8	036434	2	BOLT U 5/16-18 X 2.09
9	036449	2	SADDLE 2 INCH
10	022129	6	WASHER LOCK M8-5/16
11	022259	4	NUT HEX 5/16-18 STEEL
12	038750	3	SCREW HHC M6-1.0 X 30 G8.8
13	044149	1	GASKET EXHAUST RING
14	0E0170A	1	EXHAUST BLANKET 988MM
15	0E8816	1	FLANGE EXHAUST 2" PIPE
16	022131	2	WASHER FLAT 3/8-M10 ZINC
17	085917	2	WASHER LOCK 3/8 SS
18	0D2611	2	SCREW HHC 3/8-16 X 1-3/4 SS
19	0F7644	2	MUFFLER STRAP
20	049813	1	NUT HEX M6 X 1.0 G8 YEL CHR
21	022473	6	WASHER FLAT 1/4-M6 ZINC
22	022097	1	WASHER LOCK M6-1/4

MODEL LE  
MATIC  
ERY CH  
(FIELD  
UIT BR  
, BAT.  
NECTOR  
NECTOR  
LD BOO  
AY 1 (S  
LAY 2  
TO/OFF  
T EXER  
RMINAL  
ANSFOR

NOT USED  
NOT USED  
BLACK-W  
RED-W  
WHITE-W  
GREEN-W

AN INP R  
RT REL  
FUB UNO REL  
2 E START  
MENT. OF  
2 V E START  
MA AUTO IN  
16 AC SENS  
LARM RE  
KFER RE  
MAN. IN  
16 AC SENS  
ANALOG  
G



# GROUP G

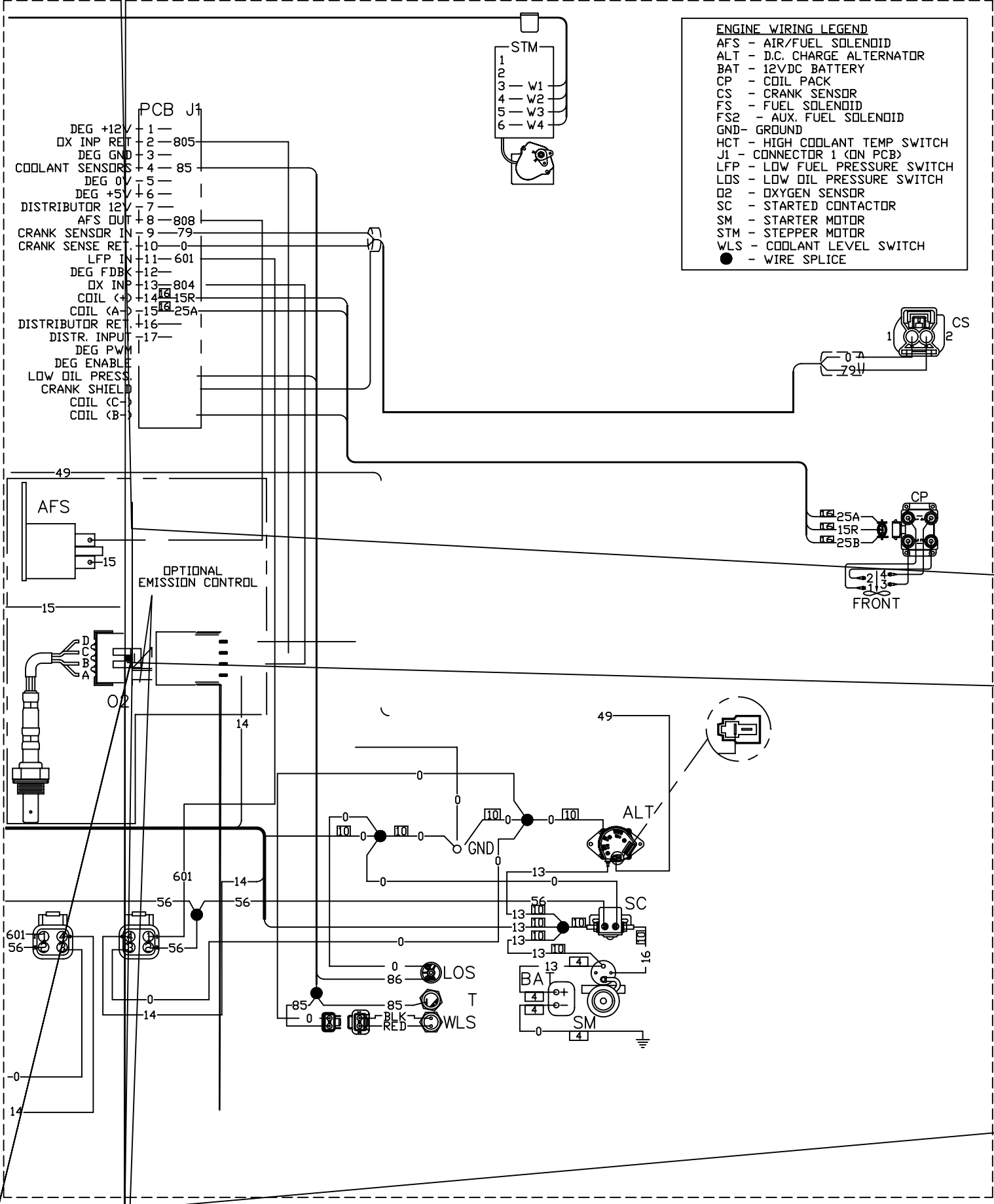

- ENGINE WIRING LEGEND**
- AFS - AIR/FUEL SOLENOID
  - ALT - D.C. CHARGE ALTERNATOR
  - BAT - 12VDC BATTERY
  - CP - COIL PACK
  - CS - CRANK SENSOR
  - FS - FUEL SOLENOID
  - FS2 - AUX. FUEL SOLENOID
  - GND- GROUND
  - HCT - HIGH COOLANT TEMP SWITCH
  - J1 - CONNECTOR 1 (ON PCB)
  - LFP - LOW FUEL PRESSURE SWITCH
  - LOS - LOW OIL PRESSURE SWITCH
  - O2 - OXYGEN SENSOR
  - SC - STARTED CONTACTOR
  - SM - STARTER MOTOR
  - STM - STEPPER MOTOR
  - WLS - COOLANT LEVEL SWITCH
  - - WIRE SPLICE

**WIRING - DIAGRAM**  
**2.5L COMMERCIAL PROD LINE**  
**DRAWING #: 0F7104**

REVISION: \*  
 DATE: 05/23/05

## CONTROL PANEL LEGEND

- AVR - AUTOMATIC VOLTAGE REGULATOR
- BCH - BATTERY CHARGER
- BR1 - BRIDGE RECTIFIER
- CB2 - CIRCUIT BREAKER (EXCITATION)
- F1 - FUSE, BAT POWER (15A ATD TYPE)
- J2 - CONNECTOR 2 (ON PCB)
- J3 - CONNECTOR 3 (ON PCB)
- R4 - FIELD BOOST RESISTOR
- RL1 - RELAY 1 (START RELAY)
- RL2 - RELAY 2 (ENGINE RUN)
- SW1 - AUTO/OFF/MANUAL SWITCH
- SW2 - SET EXERCISER SWITCH
- TR1 - TRANSFORMER 1 (6VA 240/16 VAC)

- PCB J3
- 1 - NOT USED
  - 2 - NOT USED
  - 3 - BLACK-W1
  - 4 - RED-W2
  - 5 - WHITE-W3
  - 6 - GREEN-W4

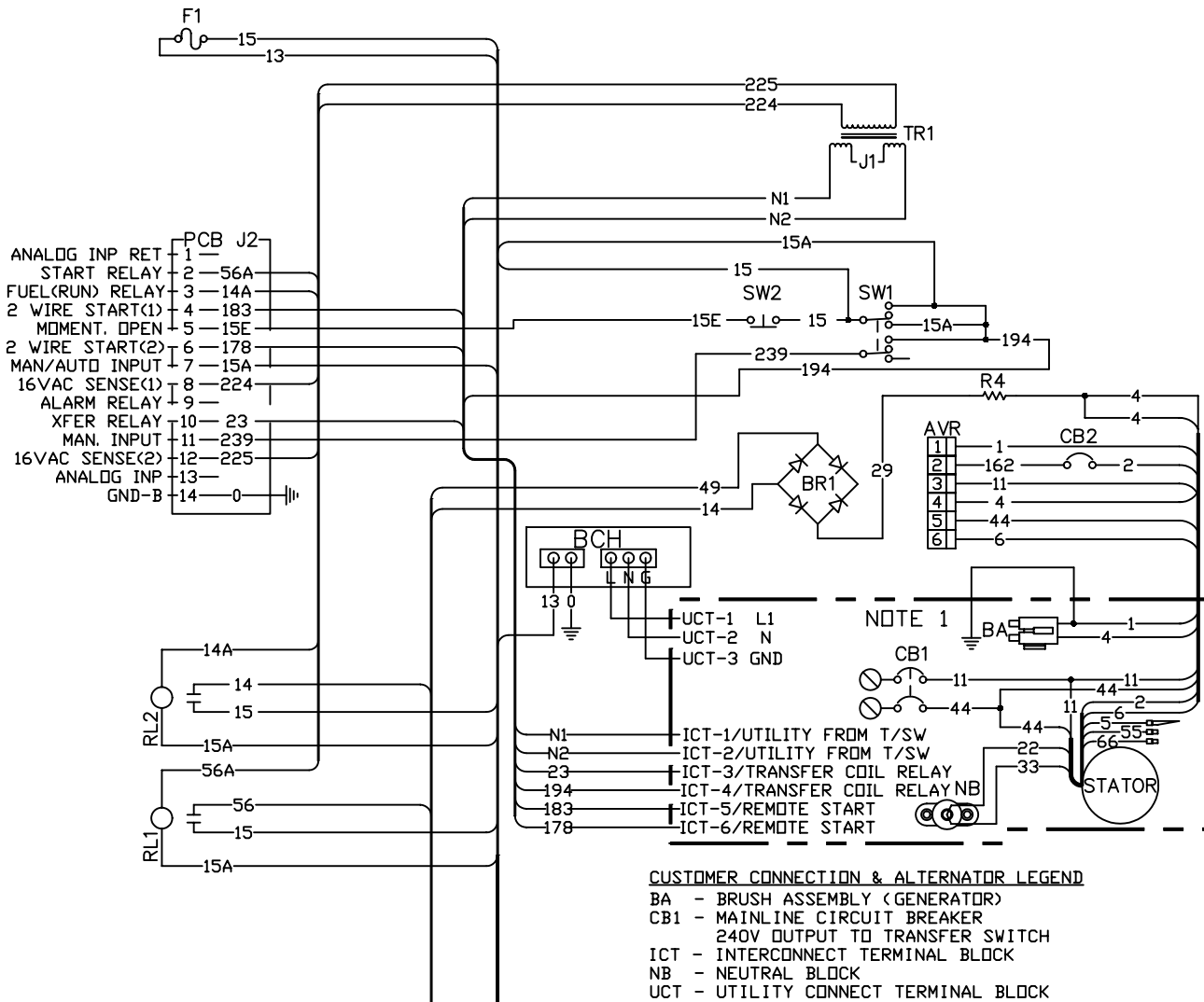

SCHMATIC - DIAGRAM

2.5L COMM PROD LINE

DRAWING #: 0F7420

REVISION: \*

DATE: 08/04/05



LFP INP  
DEG FDBK  
OX INP  
COIL (A-)  
COIL (A-)  
DISTRIBUTOR RET.  
DISTR. INPUT  
DEG PWM  
n  
COIL (C-)  
COIL (B-)

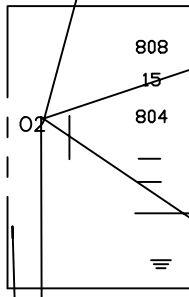

**EXPLODED VIEW: INSTALL DWG 1.5L 20KW AND 2.5L 25KW**

**DRAWING #: 0F7555**

**GROUP G**

**APPLICABLE TO:**

WEIGHT DATA	
1. 5L 20KW -	289KG [774.5lb]
2. 5L 25KW -	389KG [1043lb]
WOODEN SHIPPING SKIDS INCREASE OVERALL WEIGHT - T. B. D.	

NOTES:

- 1) MINIMUM RECOMMENDED CONCRETE PAD SIZE: 1346 (53.0') WIDE X 2413 (95.0') LONG. REFERENCE INSTALLATION GUIDE P/N OF5298 FOR CONCRETE PAD REINFORCEMENT AND PAD DEPTH GUIDELINES.
- 2) GENERATOR MUST BE LOCATED A MINIMUM DISTANCE OF 5 FEET FROM A WALL OR FENCE. ALLOW A 5 FOOT MINIMUM PERIMETER OF OPEN SPACE AROUND THE ENTIRE GENERATOR. REFERENCE INSTALLATION GUIDE P/N OF5298 FOR OUTDOOR ROOF MOUNTED APPLICATIONS.
- 3) CIRCUIT BREAKER INFORMATION:  
SEE SPECIFICATION SHEET WITHIN OWNERS MANUAL
- 4) INSIDE STUB-UP AREA FOR AC LOAD LEAD CONDUIT CONNECTION, NEUTRAL CONNECTION, BATTERY CHARGER 120 VOLT AC (.5 AMP MAX.) CONNECTION, AND ACCESS TO TRANSFER SWITCH CONTROL WIRES. REMOVE FRONT COVER FOR ACCESS.
- 4A) FIELD CUT HOLE IS ONLY REQUIRED FOR MOUNTING OF GENERATOR ON AN EXISTING PAD.
- 5) REFERENCE OWNERS MANUAL FOR LIFTING WARNINGS.
- 6) REMOVE LIFT-OFF ENCLOSURE TO ACCESS EXHAUST MUFFLER.

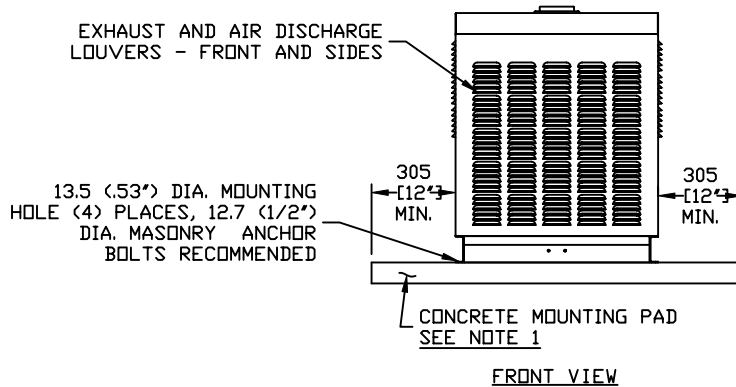

APPLICABLE TO:

SERVICE ITEM ACCESSIBILITY CHART

SERVICE ITEM	1. 5L 20KW	2. 5L 25KW
OIL FILL CAP	EITHER DOOR	EITHER DOOR
OIL DIP STICK	THRU LEFT DOOR	THRU LEFT DOOR
OIL FILTER	THRU RIGHT DOOR	THRU LEFT DOOR
OIL DRAIN HOSE	THRU RIGHT DOOR	THRU RIGHT DOOR
RADIATOR DRAIN HOSE	THRU LEFT DOOR	THRU LEFT DOOR
AIR CLEANER ELEMENT	THRU RIGHT DOOR	THRU LEFT DOOR
SPARK PLUGS	THRU LEFT DOOR	THRU LEFT DOOR
MUFFLERS	SEE NOTE 6	SEE NOTE 6
FAN BELT	EITHER DOOR	EITHER DOOR
BATTERY	THRU RIGHT DOOR	THRU LEFT DOOR

REFERENCE OWNERS MANUAL FOR PERIODIC REPLACEMENT PART LISTINGS

REMOVE COVER FOR ACCESS TO RADIATOR FILL CAP

708 [27.87'] TYP

90 [3.54']

STUB-UP AREA SEE NOTE 4

388.5 [15.3']

173.25 [6.82']

100 [3.94'] TYP

13.5 (.53") DIA. MOUNTING HOLE (4) PLACES LOCATED ON BOTTOM OF GENERATOR MOUNTING FRAME

VIEW

WISE ACTION LATCH, ONE PER DOOR, ONE LIFT-OFF DOOR PER SIDE OF GENERATOR

CONTROL PANEL R

EXHAUST MUFFLERS ENCLOSED WITHIN, SEE NOTE 6

305 [12'] MIN.

30.5 [1.2'] TYP

FUEL LINE CONNECTION 3/4" NPT FEMALE COUPLING

LEFT SIDE VIEW

AIR INLET LOUVERS

FRONT COVER SEE NOTE 4

CIRCUIT BREAKER SEE NOTE 3

736 [28.98']

REAR VIEW

FIELD CUT HOLE FOR OUTSIDE CONDUIT CONNECTION ONLY, SEE NOTE 4A



## Standby Generator Sets Warranty



### GENERAC POWER SYSTEMS STANDARD LIMITED WARRANTY FOR HOME STANDBY/LIGHT COMMERCIAL PRODUCT 45kW AND BELOW

For a period of two (2) years from the date of sale, or start-up by Authorized/Certified Generac Power Systems Dealer, or branch thereof, Generac Power Systems, Inc. will, at its option, repair or replace any part(s) which, upon examination, inspection, and testing by Generac Power Systems or an Authorized/Certified Generac Power Systems Dealer, or branch thereof, is found to be defective under normal use and service, in accordance with the warranty schedule set forth below. Any equipment that the purchaser/owner claims to be defective must be examined by the nearest Authorized/Certified Generac Power Systems Dealer, or branch thereof. This warranty applies only to Generac Power Systems Generators used in "Standby" applications, as Generac Power Systems, Inc. has defined Standby, provided said generator has been properly installed and inspected on-site by appropriate personnel. Scheduled maintenance, as outlined by the generator owner's manual, is highly recommended. This should be performed by an Authorized/Certified Generac Power Systems Dealer, or branch thereof. This will verify service has been performed on the unit throughout the warranty period.

#### WARRANTY SCHEDULE

**YEARS ONE and TWO** — Limited comprehensive coverage on mileage, labor, and parts listed.

• - ALL COMPONENTS

\*Start-up and/or On-line Registration, or Registration Card, along with Proof of Purchase, must be performed and/or sent in.

#### Guidelines:

- Any and all warranty repairs and/or concerns, must be performed and/or addressed by an Authorized/Certified Generac Power Systems Dealer, or branch thereof.
- A Generac Power Systems, Inc. Transfer Switch is highly recommended to be used in conjunction with the genset. If a Non - Generac Power Systems, Inc. Transfer Switch is substituted for use and directly causes damage to the genset, no warranty coverage shall apply.
- All warranty expense allowances are subject to the conditions defined in Generac Power Systems Warranty, Policies, and Procedures Flat Rate Manual.
- Units that have been resold are not covered under the Generac Power Systems Warranty, as this Warranty is not transferable.
- Unit enclosure is only covered against rust or corrosion the first year of the warranty provision.
- Use of Non-Generac replacement part(s) will void the warranty in its entirety.
- Engine coolant heaters (block-heaters), heater controls and circulating pumps are only covered during the first year of the warranty provision (if applicable).

#### THIS WARRANTY SHALL NOT APPLY TO THE FOLLOWING:

1. Any unit built/manufactured prior to January 1, 2005.
2. Costs of normal maintenance (i.e. tune-ups, associated part(s), adjustments, loose/leaking clamps, installation and start-up).
3. Any failure caused by contaminated fuels, oils, coolants/antifreeze or lack of proper fuels, oils or coolants/antifreeze.
4. Units sold, rated or used for "Prime Power", "Trailer Mounted" or "Rental Unit" applications as Generac Power Systems have defined Prime Power, Trailer Mounted or Rental Unit. Contact a Generac Power Systems Distributor for Prime Power, Trailer Mounted or Rental Unit definition and warranty.
5. Units used for prime power in place of existing utility power where utility is present or in place of utility power where utility power service does not normally exist.
6. Failures caused by any external cause or act of God such as, but not limited to, collision, fire, theft, freezing, vandalism, riot or wars, lightning, earthquake, windstorm, hail, volcanic eruption, water or flood, tornado, hurricane, terrorist acts or nuclear holocaust.
7. Products that are modified or altered in a manner not authorized by Generac Power Systems in writing.
8. Failures due, but not limited to, normal wear and tear, accident, misuse, abuse, negligence, or improper installation or sizing.
9. Any incidental, consequential or indirect damages caused by defects in materials or workmanship, or any delay in repair or replacement of the defective part(s).
10. Failure due to misapplication, misrepresentation, or bi-fuel conversion.
11. Telephone, facsimile, cell phone, satellite, internet, or any other communication expenses.
12. Rental equipment used while warranty repairs are being performed (i.e. rental generators, cranes, etc.).
13. Overtime, holiday, or emergency labor.
14. Planes, ferries, railroad, busses, helicopters, snowmobiles, snow-cats, off-road vehicle or any other mode of transportation deemed abnormal.
15. Any and all expenses incurred investigating performance complaints unless defective Generac materials and/or workmanship were the direct cause of the problem.
16. Starting batteries, fuses, light bulbs, engine fluids, and overnight freight cost for replacement part(s).

THIS WARRANTY IS IN PLACE OF ALL OTHER WARRANTIES, EXPRESSED OR IMPLIED, SPECIFICALLY, GENERAC POWER SYSTEMS MAKES NO OTHER WARRANTIES AS TO THE MERCHANTABILITY OR FITNESS FOR A PARTICULAR PURPOSE. Some states do not allow limitations on how long an implied warranty lasts, so the above limitation may not apply to purchaser/owner.

GENERAC POWER SYSTEMS ONLY LIABILITY SHALL BE THE REPAIR OR REPLACEMENT OF PART(S) AS STATED ABOVE. IN NO EVENT SHALL GENERAC POWER SYSTEMS BE LIABLE FOR ANY INCIDENTAL, OR CONSEQUENTIAL DAMAGES, EVEN IF SUCH DAMAGES ARE A DIRECT RESULT OF GENERAC POWER SYSTEMS, INC. NEGLIGENCE.

Some states do not allow the exclusion or limitation of incidental or consequential damages, so the above limitations may not apply to purchaser/owner. Purchaser/owner agrees to make no claims against Generac Power Systems, Inc. based on negligence. This warranty gives purchaser/owner specific legal rights. Purchaser/owner also may have other rights that vary from state to state.

**Generac Power Systems, Inc. · P.O. Box 8 · Waukesha, WI 53187**  
**Ph: (262) 544-4811 · Fax: (262) 544-4851**

Bulletin 0171360SVE / Printed in U.S.A. 7.05

Printed in U.S.A.