

GENERAC®

POWER SYSTEMS, INC.

PowerMaster Technical Manual

This manual should remain with the unit.

—▲ **DANGER** ▲—

**ONLY QUALIFIED ELECTRICIANS OR CONTRACTORS
SHOULD ATTEMPT INSTALLATION!**

INTRODUCTION

Thank you for purchasing the PowerMaster Assembly by Generac Power Systems, Inc.

Every effort was expended to make sure that the information and instructions in this manual were both accurate and current at the time the manual was written. However, the manufacturer reserves the right to change, alter or otherwise improve this product(s) at any time without prior notice.

◆ READ THIS MANUAL THOROUGHLY

If any portion of this manual is not understood, contact the nearest Authorized Service Dealer for starting, operating and servicing procedures.

Throughout this publication, and on tags and decals affixed to the generator, DANGER, WARNING, CAUTION and NOTE blocks are used to alert personnel to special instructions about a particular service or operation that may be hazardous if performed incorrectly or carelessly. Observe them carefully. Their definitions are as follows:



After this heading, read instructions that, if not strictly complied with, will result in personal injury or property damage.



After this heading, read instructions that, if not strictly complied with, may result in personal injury or property damage.



After this heading, read instructions that, if not strictly complied with, could result in damage to equipment and/or property.

NOTE:

After this heading, read explanatory statements that require special emphasis.

These safety warnings cannot eliminate the hazards that they indicate. Common sense and strict compliance with the special instructions while performing the service are essential to preventing accidents.

Four commonly used safety symbols accompany the DANGER, WARNING and CAUTION blocks. The type of information each indicates is as follows:

 This symbol points out important safety information that, if not followed, could endanger personal safety and/or property of others.

 This symbol points out potential explosion hazard.

 This symbol points out potential fire hazard.

 This symbol points out potential electrical shock hazard.

The operator is responsible for proper and safe use of the equipment. The manufacturer strongly recommends that the operator read this Owner's Manual and thoroughly understand all instructions before using this equipment. The manufacturer also strongly recommends instructing other users to properly start and operate the unit. This prepares them if they need to operate the equipment in an emergency.

◆ OPERATION AND MAINTENANCE

It is the operator's responsibility to perform all safety checks, to make sure that all maintenance for safe operation is performed promptly, and to have the equipment checked periodically by an Authorized Service Dealer. Normal maintenance service and replacement of parts are the responsibility of the owner/operator and, as such, are not considered defects in materials or workmanship within the terms of the warranty. Individual operating habits and usage contribute to the need for maintenance service.

Proper maintenance and care of the generator ensures a minimum number of problems and keep operating expenses at a minimum. See an Authorized Service Dealer for service aids and accessories.

Operating instructions presented in this manual assume that the standby electric system has been installed by an Authorized Service Dealer or other competent, qualified contractor. Installation of this equipment is not a "do-it-yourself" project.

◆ HOW TO OBTAIN SERVICE

When the generator requires servicing or repairs, contact an Authorized Service Dealer for assistance. Service technicians are factory-trained and are capable of handling all service needs.

When contacting an Authorized Service Dealer about parts and service, always supply the complete model number of the unit as given on the front cover of this manual or on the DATA LABEL affixed to the unit.

AUTHORIZED DEALER LOCATION

To locate the nearest AUTHORIZED SERVICE DEALER, please call:

1-800-333-1322

or visit the website at:
www.generac.com

IntroductionInside Front Cover

Read This Manual Thoroughly IFC
Operation and Maintenance IFC
How to Obtain Service..... IFC
Authorized Dealer Locator Number IFC

Safety Rules2

Section 1 – General Information4

1.1 Introduction4
1.2 Equipment Description4
1.3 Unpacking the Box4
1.4 Enclosure Details4

Section 2 – Installation4

2.1 Introduction to Installation..... 4
2.2 Mounting the Enclosure 4
2.3 Connecting the Source Voltage(s)
and Load(s) 5
2.3.1 Load #1 Connection Instructions 5
2.3.2 Load #2 Connection Instructions 5
2.4 Connecting the Control Circuits 5
2.4.1 Control Circuit #1 Connections..... 5
2.4.2 Control Circuit #2 Connections..... 5
2.5 Installing the Auxiliary Switches
to the Transfer Switch..... 6
2.6 Connecting the Auxiliary Switches..... 6
2.6.1 Generator Side Auxiliary Switch 6
2.6.2 Utility Side Auxiliary Switch..... 6
2.7 Restoring All Power Supplies 6

Section 3 – Operation7

3.1 Testing the PowerMaster Operation..... 7

Section 4 – Electrical Data8

**Section 5 – Exploded Views &
Parts Lists 10**

Section 6 – Notes 12

Section 7 – Warranty Back Cover



⚠ SAVE THESE INSTRUCTIONS – This manual contains important instructions that should be followed during installation and maintenance of the generator and batteries. The manufacturer suggests that these rules for safe operation be copied and posted in potential hazard areas. Safety should be stressed to all operators and potential operators of this equipment. ⚠



• WARNING:



- The engine exhaust from this product contains chemicals known to the state of California to cause cancer, birth defects or other reproductive harm.



• WARNING:



- This product contains or emits chemicals known to the state of California to cause cancer, birth defects or other reproductive harm.

Study these SAFETY RULES carefully before installing, operating or servicing this equipment. Become familiar with this Owner's Manual and with the unit. The generator(s) can operate safely, efficiently and reliably only if it is properly installed, operated and maintained. Many accidents are caused by failing to follow simple and fundamental rules or precautions.

The manufacturer cannot anticipate every possible circumstance that might involve a hazard. The warnings in this manual, and on tags and decals affixed to the unit are, therefore, not all-inclusive. If using a procedure, work method or operating technique the manufacturer does not specifically recommend, ensure that it is safe for others. Also make sure the procedure, work method or operating technique utilized does not render the generator(s) unsafe.

— ⚠ DANGER ⚠ —

- ⚠ Despite the safe design of the generator(s), operating this equipment imprudently, neglecting its maintenance or being careless can cause possible injury or death. Permit only responsible and capable persons to operate or maintain this equipment.
- ⚠ Potentially lethal voltages are generated by these machines. Ensure all steps are taken to render the machine safe before attempting to work on the generator(s).
- ⚠ Parts of the generator(s) are rotating and/or hot during operation. Exercise care near running generators.

⚠ GENERAL HAZARDS ⚠

- For safety reasons, the manufacturer requires that the installation, initial start-up and maintenance of this equipment is carried out by an Authorized Dealer.
- The engine exhaust fumes contain carbon monoxide, which can be DEADLY. This dangerous gas, if breathed in sufficient concentrations, can cause unconsciousness or even death. This exhaust system must be installed properly, in strict compliance with applicable codes and standards. Following installation, do nothing that might render the system unsafe or in noncompliance with such codes and standards.
- Keep hands, feet, clothing, etc., away from drive belts, fans, and other moving or hot parts. Never operate the unit with any drive belt or fan guard removed.
- Adequate, unobstructed flow of cooling and ventilating air is critical to correct generator(s) operation. Do not alter the installation or permit even partial blockage of ventilation provisions, as this can seriously affect safe operation of the generator(s).
- When working on this equipment, remain alert at all times. Never work on the equipment when physically or mentally fatigued.
- Inspect the generator(s) regularly, and repair or replace all damaged or defective parts immediately. Always use factory-authorized parts.
- Turn off the AC power to the battery charger before disconnecting the battery to minimize the chance of equipment damage.
- Before performing any maintenance on the generator(s), disconnect its battery cables to prevent accidental start-up. Remove control panel fuse, then disconnect the cable from the battery post indicated by a NEGATIVE, NEG or (–) first. Reconnect that cable last, then reinstall control panel fuse.
- Never use the generator(s) or any of its parts as a step. Stepping on the unit can stress and break parts, and may result in dangerous operating conditions from leaking exhaust gases, fuel leakage, oil leakage, etc.



 ELECTRICAL HAZARDS 

- All generators covered by this manual produce dangerous electrical voltages and can cause fatal electrical shock. Utility power delivers extremely high and dangerous voltages to the transfer switch as does the standby generator when it is in operation. Avoid contact with bare wires, terminals, connections, etc., while the unit is running. Ensure all appropriate covers, guards and barriers are in place before operating the generator(s). If working around an operating unit, stand on an insulated, dry surface to reduce shock hazard.
- Do not handle any kind of electrical device while standing in water, while barefoot, or while hands or feet are wet. DANGEROUS ELECTRICAL SHOCK MAY RESULT.
- The National Electrical Code (NEC) requires the frame and external electrically conductive parts of the generator to be connected to an approved earth ground and/or grounding rods. Local electrical codes also may require proper grounding of the generator electrical system.
- After installing this standby electrical system, the generator(s) may crank and start at any time without warning. When this occurs, load circuits are transferred to the STANDBY (generator) power source. To prevent possible injury if such a start and transfer occur, always set the generator's AUTO/OFF/MANUAL switch to its OFF position before working on equipment and remove the negative battery lead.
- In case of accident caused by electric shock, immediately shut down the source of electrical power. If this is not possible, attempt to free the victim from the live conductor. AVOID DIRECT CONTACT WITH THE VICTIM. Use a nonconducting implement, such as a rope or board, to free the victim from the live conductor. If the victim is unconscious, apply first aid and get immediate medical help.
- Never wear jewelry when working on this equipment. Jewelry can conduct electricity resulting in electric shock, or may get caught in moving components causing injury.
- The enclosure door on this unit is grounded to the chassis with a wire. The grounding wire must be reconnected when the door is replaced to reduce the risk of electric shock.

 FIRE HAZARDS 

- For fire safety, the generator(s) must be installed and maintained properly. Installation always must comply with applicable codes, standards, laws and regulations. Adhere strictly to local, state and national electrical and building codes. Comply with regulations the Occupational Safety and Health Administration (OSHA) has established. Also, ensure that the generator(s) is installed in accordance with the manufacturer's instructions and recommendations. Following proper installation, do nothing that might alter a safe installation and render the unit in noncompliance with the aforementioned codes, standards, laws and regulations.
- Keep a fire extinguisher near the generator(s) at all times. Extinguishers rated "ABC" by the National Fire Protection Association are appropriate for use on the standby electric system. Keep the extinguisher properly charged and be familiar with its use. If there are any questions pertaining to fire extinguishers, consult the local fire department.

 EXPLOSION HAZARDS 

- Do not smoke around the generator(s). Wipe up any fuel or oil spills immediately. Ensure that no combustible materials are left in the generator(s) compartment, or on or near the generator(s), as FIRE or EXPLOSION may result. Keep the area surrounding the generator(s) clean and free from debris.

1.1 INTRODUCTION

This manual has been prepared especially for the purpose of familiarizing personnel with the design, application, installation, and operation of the applicable equipment. Read the manual carefully and comply with all instructions. This will help to prevent accidents or damage to equipment that might otherwise be caused by carelessness, incorrect application, or improper procedures.

Every effort has been expended to make sure that the contents of this manual are both accurate and current. The manufacturer, however, reserves the right to change, alter or otherwise improve the product at anytime without prior notice.

1.2 EQUIPMENT DESCRIPTION

The PowerMaster assembly is used to automatically disconnect selected loads from the generator output when a high demand appliance, such as a central air conditioning system, is started, easing the burden on the generator. The selected loads will then be automatically reconnected to the generator output once the high demand appliance is turned off. The selected loads will only be disconnected if the transfer switch is in the generator position when the high demand appliance is started.

A total of up to two 240V, 30Amp loads can be connected to the system, and be controlled by a total of up to two 24Vac control signals from various high demand appliances.

Once installation is completed, the PowerMaster assembly will operate automatically without any need for user intervention or routine maintenance.

1.3 UNPACKING THE BOX

Carefully unpack the box and check for any damage that may have occurred during shipping. Check to make certain all the following items are included:

Qty.	Part No.	Description
1	0F9110	PowerMaster assembly
1	0G0734	Manual, installation and operating instructions
2	084464	Auxiliary contact switches
4	027770	Screws for mounting the auxiliary contact switches
4	043182	Washers for mounting the auxiliary contact switches
4	059051	Lug, Ring, #8 screw, 10-12AWG
4	079679	Lug, Fast-on, 3/16 inch, 18-22AWG

1.4 ENCLOSURE DETAILS

The enclosure is a National Electrical Manufacturer's Association (NEMA) 1 type. NEMA 1 type enclosures are suitable only for indoor mounting.

2.1 INTRODUCTION TO INSTALLATION

This equipment has been wired and tested at the factory.

Installing this assembly includes the following procedures:

- Mounting the enclosure
- Connecting the source voltage(s) and load(s)
- Connecting the control circuit(s)
- Installing the Auxiliary switches to the transfer switch
- Connecting the Auxiliary switches
- Restoring all power supplies
- Testing the PowerMaster operation

2.2 MOUNTING THE ENCLOSURE

Mounting dimensions for the enclosure are shown in figure 1.

The enclosure should be wall mounted in an indoor location only, preferably near the circuit breaker load center. Mount the assembly vertically to a rigid supporting structure. To prevent distortion, level all mounting points. If necessary, use washers behind the mounting holes to level the assembly.

Figure 1 — Mounting Dimensions

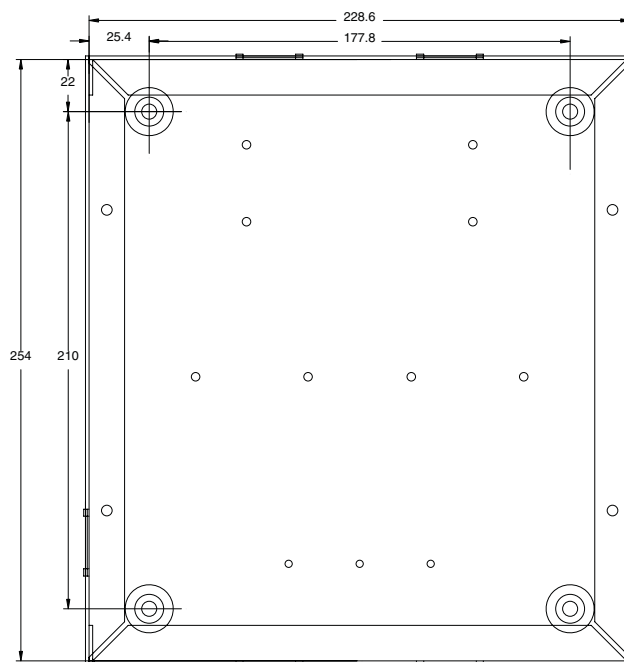

2.3 CONNECTING THE SOURCE VOLTAGE(S) AND LOAD(S)

The source voltage(s) are taken from the load center and connected to the PowerMaster assembly as follows:

- Refer to the system diagram and the wiring diagram located in this manual.
- Refer to the field wiring decal on the inside of the enclosure cover for the contactor connection points and required tightening torque.



▲ **Make sure to turn OFF both the UTILITY (NORMAL) and EMERGENCY (STANDBY) power supplies before trying to connect the source voltages and the loads. Supply voltages are high and dangerous. Contact with such high power supply lines will result in extremely hazardous, possibly lethal, electrical shock.**

Do not turn these supplies back on until the PowerMaster installation has been completed in its entirety.

◆ 2.3.1 LOAD #1 CONNECTION INSTRUCTIONS

1. Select a 240V load to be automatically disconnected by the PowerMaster assembly.
2. Remove the load connections from the 240V 2-Pole circuit breaker in the load center controlling the selected load.
3. Using a suitable wiring method, sized as 10AWG stranded wire, route the wiring between the load center and the load disconnect box. Using the ring lugs provided, connect the 2-Pole circuit breaker to the “Line 1A” and “Line 1B” connections on contactor K1 in the PowerMaster assembly.

When making the connections to the contactor, strip the 10AWG wire 0.312 inch (5/16”) and use an appropriate crimping tool to crimp the ring lugs.

4. Using the ring lugs provided, connect the load connections removed in step #2 above to the “Load 1A” and “Load 1B” connections on contactor K1.

Strip the wire 0.312 inch (5/16”) and use an appropriate crimping tool to crimp the ring lugs. Tighten the terminal screws to 20-22 inch/pounds.

◆ 2.3.2 LOAD #2 CONNECTION INSTRUCTIONS

If desired, a second load can be connected to contactor K2 in the same manner.

2.4 CONNECTING THE CONTROL CIRCUITS

The PowerMaster Load center is controlled by a 24Vac control voltage. The most common application is to use the 24Vac control signal from a furnace or central air conditioning system, but any 24Vac control signal may be used.

A total of two 24Vac control signals may be connected to the PowerMaster load center. Any time either of the two 24Vac control signals is active, both contactors will be energized disconnecting both of the selected loads.

The 24Vac control signals should be connected as follows:

- Refer to the system diagram and the wiring diagram located in this manual.
- Refer to the field wiring decal on the inside of the enclosure cover for the control signal connection points.

◆ 2.4.1 CONTROL CIRCUIT #1 CONNECTIONS



▲ **To prevent damage to the appliance control circuitry, or possible electrical shock, be sure to disconnect all power sources to the appliance before making these connections.**

Do not restore power to the appliance until the PowerMaster installation has been completed in its entirety.

Using a minimum of 18AWG wire, connect the 24Vac control signal from the Air conditioner (or other high demand appliance) to the two 24Vac control circuit 1 connections on the terminal strip inside the PowerMaster assembly.

The 18AWG wire should be stripped to ¼ inch length before inserting into the terminal strip. Tighten the terminal strip clamping screws to 7 inch pounds.

◆ 2.4.2 CONTROL CIRCUIT #2 CONNECTIONS

If desired, a second 24Vac control signal can be connected to the PowerMaster assembly. The second control signal should be connected to the two 24Vac control circuit 2 connections on the terminal strip inside the PowerMaster assembly.

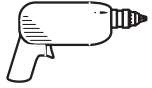

2.5 INSTALLING THE AUXILIARY SWITCHES TO THE TRANSFER SWITCH

The included auxiliary switches need to be added to the transfer switch to provide switch position sensing to the PowerMaster assembly. This allows the PowerMaster assembly to disconnect the selected loads only when the transfer switch is in the generator position. These switches should be installed as follows: Refer to figure 2.

Figure 2 — Auxiliary Switch Installation

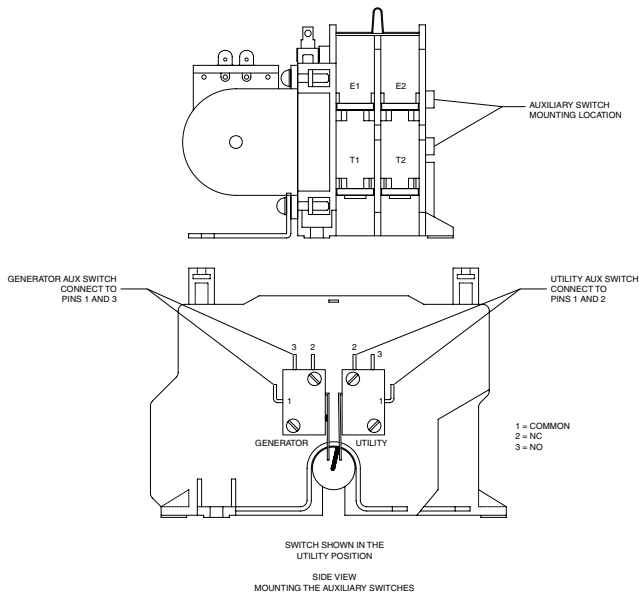

⚠ WARNING ⚠

⚠ There are multiple voltage sources present inside the transfer switch enclosure. Make sure to turn OFF both the UTILITY (NORMAL) and the EMERGENCY (STANDBY) power sources before installing the auxiliary switches. Failure to do so could result in an extremely hazardous, possibly lethal, electrical shock.

Do not turn these supplies back on until the PowerMaster installation has been completed in it's entirety.

Mount the two auxiliary switches (provided) to the transfer switch using the four screws and four washers (provided) as shown in figure 2.

2.6 CONNECTING THE AUXILIARY SWITCHES

The auxiliary switches need to be connected to the PowerMaster assembly using a minimum of 18AWG wire as follows: Refer to figure 2.

◆ 2.6.1 GENERATOR SIDE AUXILIARY SWITCH

1. Connect one end of each of the two 18AWG wires to the generator auxiliary switch.
 - Strip the 18AWG wire 0.234 inch (15/64") and use an appropriate crimping tool to crimp the 3/16" fast on lugs (provided).
 - The two wires should be connected to pins 1 and 3 on the generator auxiliary switch.
2. Connect the other end of the two wires to the Control Circuit 1 COM and N.O. positions on the terminal strip inside the PowerMaster assembly.
 - These wires are not polarity sensitive.
 - These wires should be stripped 0.25 inch (1/4") before being inserted into the terminal strip.
 - The terminal strip clamping screws should be tightened to 7 inch pounds.

◆ 2.6.2 UTILITY SIDE AUXILIARY SWITCH

1. Connect one end of each of the two 18AWG wires to the utility auxiliary switch.
 - Strip the 18AWG wire 0.234 inch (15/64") and use an appropriate crimping tool to crimp the 3/16" fast on lugs (provided).
 - The two wires should be connected to pins 1 and 2 on the utility auxiliary switch.
2. Connect the other end of the two wires to the Control Circuit 2 COM and N.O. positions on the terminal strip inside the PowerMaster assembly.
 - These wires are not polarity sensitive.
 - These wires should be stripped 0.25 inch (1/4") before being inserted into the terminal strip.
 - The terminal strip clamping screws should be tightened to 7 inch pounds.

2.7 RESTORING ALL POWER SUPPLIES

Now that the PowerMaster installation is completed:

1. Restore power to the appliance(s) disconnected in section 2.4.
2. Turn the UTILITY (NORMAL) and EMERGENCY (STANDBY) power supplies back ON.

3.1 TESTING THE POWERMASTER OPERATION

The PowerMaster assembly can be functionally tested using the following steps:

Note: the following steps will reference a central air conditioner being used as the high demand appliance controlling the PowerMaster assembly.

1. Ensure the Utility supply is available and the transfer switch is in the utility position.
 - Ensure the Central air conditioner is not running.
 - Check for proper operation of the load(s) connected to the PowerMaster assembly.
2. Run the Central air conditioner.
 - Check for proper operation of the load(s) connected to the PowerMaster assembly.
3. Stop the central air conditioner.
 - Check for proper operation of the load(s) connected to the PowerMaster assembly.
4. Simulate a utility loss.
 - Wait for the generator to start and run.
 - Wait for the transfer switch to transfer to the Standby position.
 - Ensure the Central air conditioner is still not running.
 - Check for proper operation of the load(s) connected to the PowerMaster assembly.
5. Run the central air conditioner.
 - Contactors K1 and K2 should both energize disconnecting the load(s) connected to the PowerMaster assembly.
 - Verify the load(s) connected to the PowerMaster assembly no longer operate.
6. Stop the central air conditioner.
 - Contactors K1 and K2 should both de-energize reconnecting the load(s) connected to the PowerMaster assembly.
 - Check for proper operation of the load(s) connected to the PowerMaster assembly.
7. Return the utility supply.
 - Wait for the transfer switch to return to the utility position.
 - Wait for the generator to go through it's cool down period and shut off.
 - Check for proper operation of the load(s) connected to the PowerMaster assembly.

Testing completed.

Figure 3 — System Diagram

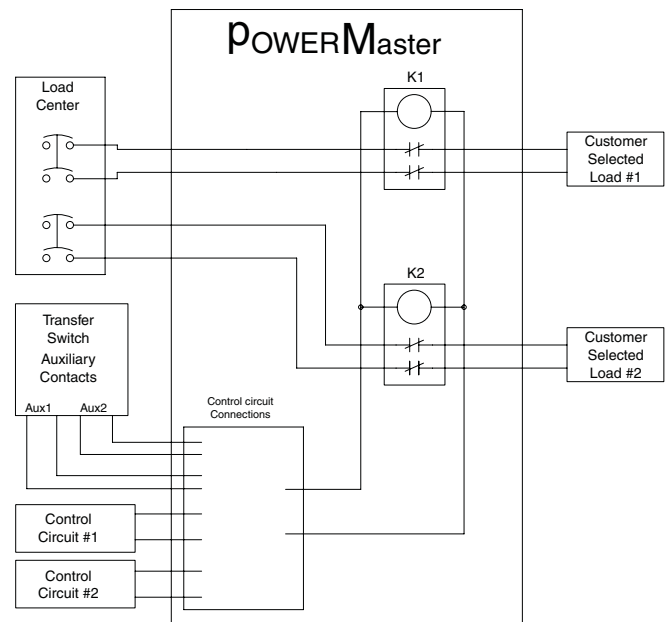

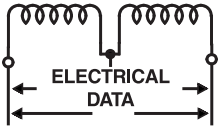

Section 4 – Electrical Data
Electrical Schematic - Drawing No. 0F8146-A

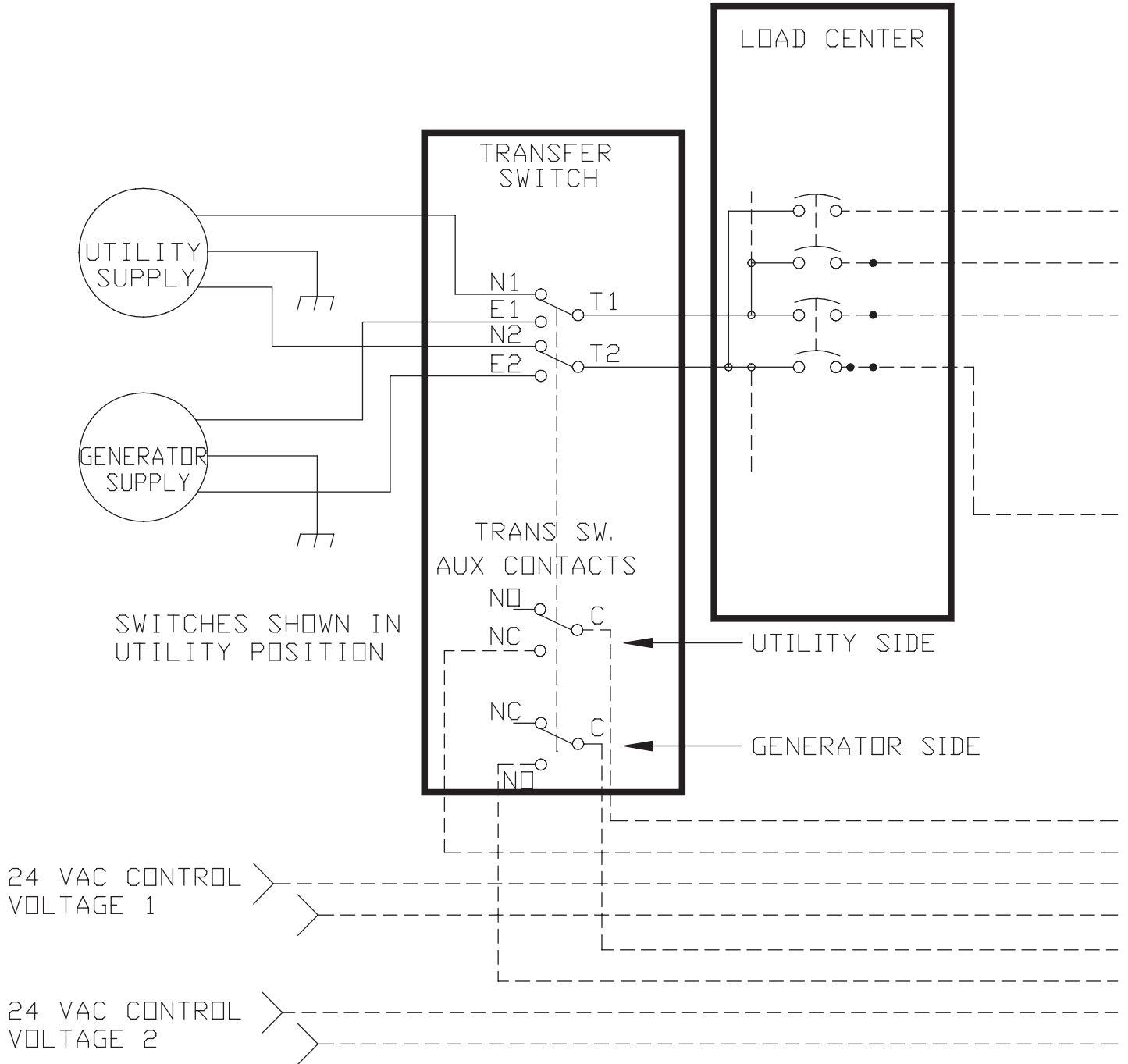

Section 4 – Electrical Data
 Electrical Schematic - Drawing No. 0F8146-A

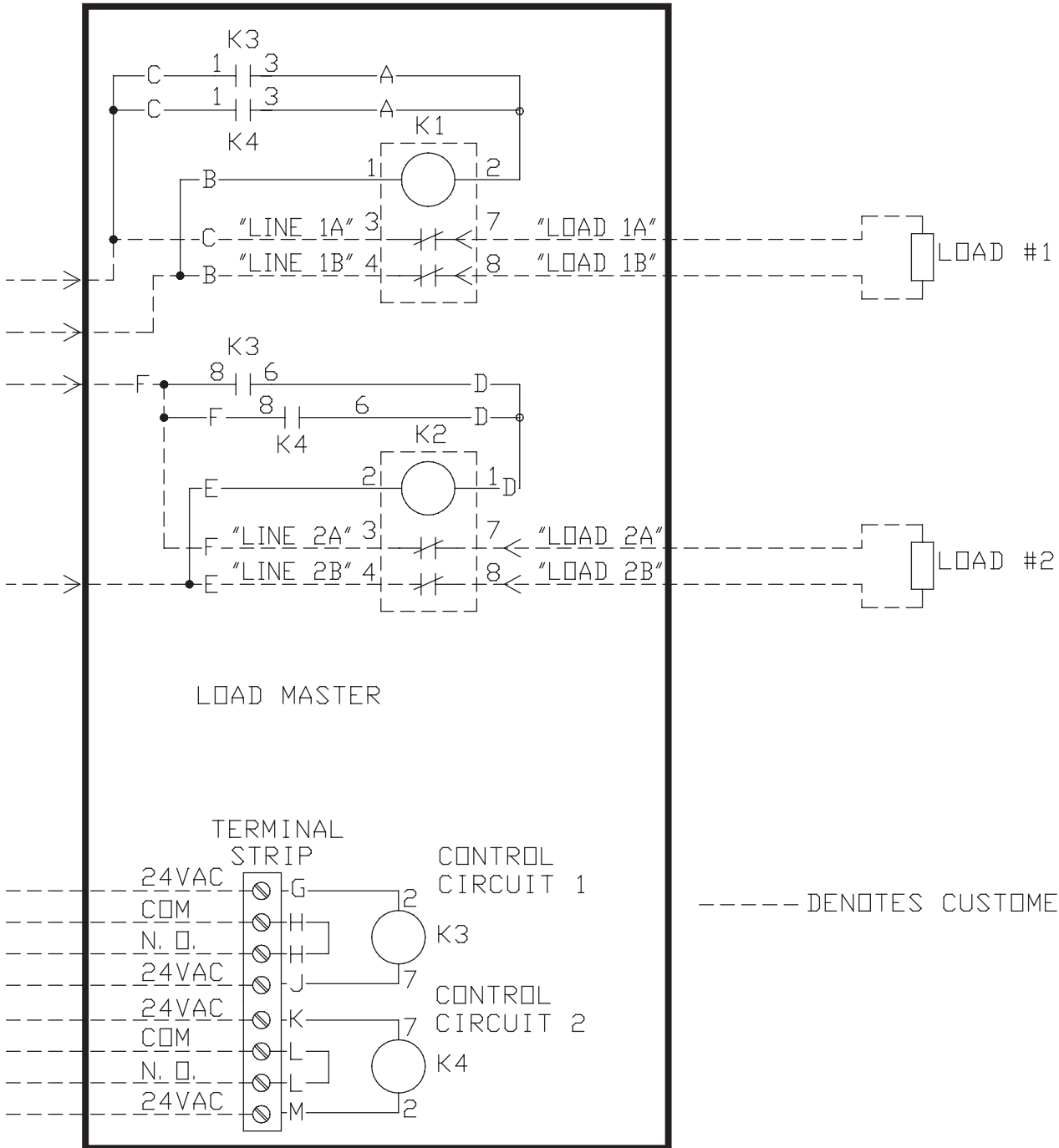
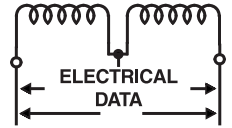

Section 5 – Exploded Views & Parts Lists

Assembly - Drawing No. 0F9110-A

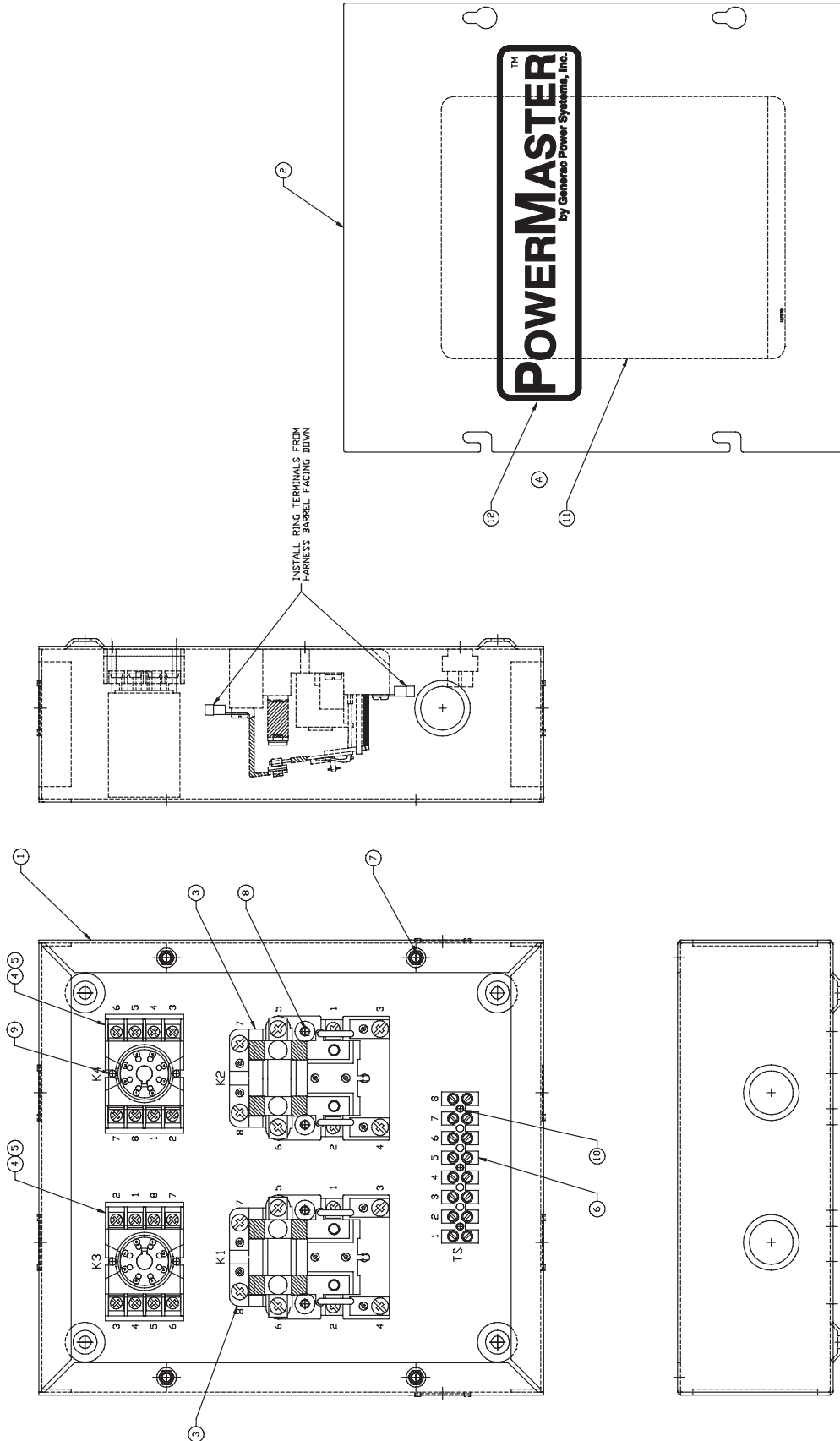

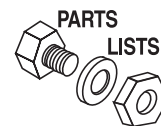
Section 5 – Exploded Views & Parts Lists**Assembly - Drawing No. 0F9110-A**

ITEM	PART NO.	QTY.	DESCRIPTION
1	0F9080	1	LOAD DISCONNECT ENCLOSURE
2	0F9081	1	LOAD DISCONNECT ENCLOSURE COVER
3	0C3211T	2	RELAY 40A @ 300VAC DPDT
4	0C3211U	2	RELAY DPDT 24VAC 5A 8 PIN
5*	0C3211G	2	SOCKET RELAY 8 PIN
6*	0F9072	1	BLOCK TERM 10MM 8 POS MOLEX
7	074908	4	SCREW HHTT M5-0.8 X 10BP
8	0C2265	4	SCREW PHTT M5-0.7 X 12 ZYC
9	0C2695	4	SCREW PHTT M4-0.7 X 20 ZYC
10	0C2323	3	SCREW PHTT #6-32 X 5/8 ZYC
11	0F9151	1	DECAL, FIELD WIRING
12	0F9152	1	DECAL, FRONT COVER
13	0F9148	1	HARNESS, POWERMASTER (NOT SHOWN)

* STRUCTURED ON HARNESS



Section 7 – Warranty
PowerMaster Technical Manual

**GENERAC POWER SYSTEMS STANDARD TWO-YEAR LIMITED WARRANTY
FOR GENERAC TRANSFER SWITCH SYSTEMS**

NOTE: ALL UNITS MUST HAVE A START-UP INSPECTION PERFORMED BY AN AUTHORIZED GENERAC DEALER.

For a period of two (2) years or two thousand (2,000) hours of operation from the date of sale, which ever occurs first, Generac Power Systems, Inc. will, at its option, repair or replace any part(s) which, upon examination, inspection, and testing by Generac Power Systems or an Authorized/Certified Generac Power Systems Dealer, or branch thereof, is found to be defective under normal use and service, in accordance with the warranty schedule set forth below. Any equipment that the purchaser/owner claims to be defective must be examined by the nearest Authorized/Certified Generac Power Systems Dealer, or branch thereof. This warranty applies only to Generac Power Systems Transfer Switch used in "Standby" applications, as Generac Power Systems, Inc. has defined Transfer Switch applications, provided said generator has been initially installed and/or inspected on-site by an Authorized/Certified Generac Power Systems Dealer, or branch thereof. Scheduled maintenance, as outlined by the generator owner's manual, must be performed by an Authorized/Certified Generac Power Systems Dealer, or branch thereof. This will verify service has been performed on the unit throughout the warranty period. This warranty is limited to and available only on Liquid-cooled units.

WARRANTY SCHEDULE

YEAR ONE — One hundred percent (100%) coverage on mileage, labor, and parts listed.

- ALL COMPONENTS

YEAR TWO — One hundred percent (100%) coverage on parts listed.

- ALL COMPONENTS — PARTS ONLY

Guidelines:

Travel allowance is limited to 300 miles maximum, and 7.5 hours maximum (per occurrence), round trip, to the nearest authorized Generac Service Facility, and only applies to permanently wired and mounted units.

- Any and all warranty repairs and/or concerns, must be performed and/or addressed by an Authorized/Certified Generac Power Systems Dealer, or branch thereof.
- A Generac Power Systems, Inc. Transfer Switch is highly recommended to be used in conjunction with the generator set. If a Non-Generac Power Systems, Inc. Transfer Switch is substituted for use and directly causes damage to the generator set, no warranty coverage shall apply.
- All warranty expense allowances are subject to the conditions defined in Generac Power Systems Warranty, Policies, Procedures and Flat Rate Manual.
- Units that have been resold are not covered under the Generac Power Systems Warranty, as this Warranty is not transferable.
- Unit enclosure is only covered during the first year of the warranty provision.
- Use of Non-Generac replacement part(s) will void the warranty in its entirety.
- Engine coolant heaters (block-heaters), heater controls and circulating pumps are only covered during the first year of the warranty provision.

THIS WARRANTY SHALL NOT APPLY TO THE FOLLOWING:

1. Any unit built/manufactured prior to July 1, 2004.
2. Costs of normal maintenance (i.e. tune-ups, associated part(s), adjustments, loose/leaking clamps, installation and start-up).
3. Any failure caused by contaminated fuels, oils, coolants/antifreeze or lack of proper fuels, oils or coolants/antifreeze.
4. Units sold, rated or used for "Prime Power", "Trailer Mounted" or "Rental Unit" applications as Generac Power Systems has defined Prime Power, Trailer Mounted or Rental Unit. Contact a Generac Power Systems Distributor for Prime Power, Trailer Mounted or Rental Unit definition and warranty.
5. Failures caused by any external cause or act of God such as, but not limited to, collision, fire, theft, freezing, vandalism, riot or wars, lightning, earthquake, windstorm, hail, volcanic eruption, water or flood, tornado, hurricane, terrorist acts or nuclear holocaust.
6. Products that are modified or altered in a manner not authorized by Generac Power Systems in writing.
7. Failures due, but not limited to, normal wear and tear, accident, misuse, abuse, negligence, or improper installation or sizing.
8. Any incidental, consequential or indirect damages caused by defects in materials or workmanship, or any delay in repair or replacement of the defective part(s).
9. Damage related to rodent and/or insect infestation.
10. Failure due to misapplication, misrepresentation, or bi-fuel conversion.
11. Telephone, facsimile, cellular phone, satellite, Internet, or any other communication expenses.
12. Rental equipment used while warranty repairs are being performed (i.e. rental generators, cranes, etc.).
13. Overtime, holiday, or emergency labor.
14. Modes of transportation deemed abnormal (refer to Generac Power Systems Warranty, Policies, Procedures and Flat Rate Manual).
15. Steel enclosures that are rusting due to improper installation, location in a harsh or saltwater environment or scratched where integrity of paint applied is compromised.
16. Any and all expenses incurred investigating performance complaints unless defective Generac materials and/or workmanship were the direct cause of the problem.
17. Starting batteries, fuses, light bulbs, engine fluids, and overnight freight cost for replacement part(s).

THIS WARRANTY IS IN PLACE OF ALL OTHER WARRANTIES, EXPRESSED OR IMPLIED, SPECIFICALLY, GENERAC POWER SYSTEMS MAKES NO OTHER WARRANTIES AS TO THE MERCHANTABILITY OR FITNESS FOR A PARTICULAR PURPOSE. Some states do not allow limitations on how long an implied warranty lasts, so the above limitation may not apply to purchaser/owner.

GENERAC POWER SYSTEMS ONLY LIABILITY SHALL BE THE REPAIR OR REPLACEMENT OF PART(S) AS STATED ABOVE. IN NO EVENT SHALL GENERAC POWER SYSTEMS BE LIABLE FOR ANY INCIDENTAL, OR CONSEQUENTIAL DAMAGES, EVEN IF SUCH DAMAGES ARE A DIRECT RESULT OF GENERAC POWER SYSTEMS, INC. NEGLIGENCE.

Some states do not allow the exclusion or limitation of incidental or consequential damages, so the above limitations may not apply to purchaser/owner. Purchaser/owner agrees to make no claims against Generac Power Systems, Inc. based on negligence. This warranty gives purchaser/owner specific legal rights. Purchaser/owner also may have other rights that vary from state to state.

Generac Power Systems, Inc. · P.O. Box 8 · Waukesha, WI 53187
Ph: (262) 544-4811 · Fax: (262) 544-4851

Bulletin 0166260SBY / Printed in U.S.A. 6.04