

# OWNER'S Manual

---

Series NP-66G

## AIR-COOLED RECREATIONAL VEHICLE GENERATOR

Model No. 9600-3

**GENERAC**  

---

**C O R P O R A T I O N**  

---

# GENERAL SAFETY RULES

THE MANUFACTURER SUGGESTS THAT THESE "RULES" FOR SAFE OPERATION BE COPIED AND POSTED IN POTENTIAL HAZARD AREAS OF THE INDUSTRIAL VEHICLE. SAFETY SHOULD BE STRESSED TO ALL OPERATORS AND POTENTIAL OPERATORS OF THIS EQUIPMENT.

*Study these SAFETY RULES carefully before operating or servicing applicable equipment. Become familiar with this Owner's Manual and with your generator. Safe, efficient and reliable operation can only be achieved if generator is properly installed, operated and maintained. Many accidents are caused by failing to follow simple and fundamental rules or precautions. The manufacturer suggests that these GENERAL SAFETY RULES be copied and posted in potential hazard areas of the industrial vehicle. Safety should be stressed to all operators and potential operators of equipment.*

The manufacturer cannot possibly anticipate every possible circumstance that might involve a hazard. The warnings in this Manual and on tags and decals affixed to the unit are, therefore, not all-inclusive. If you use a procedure, work method or operating technique Generac does not specifically recommend, you must satisfy yourself that it is safe for you and others. You must also make sure the procedure, work method or operating technique that you chose does not render the generator to be unsafe.

- For fire safety, the industrial mobile generator must be properly installed and maintained. Installation must always remain in compliance with applicable codes and standards. In addition, the generator must be installed in conformance to the manufacturer's detailed installation instructions. Following installation, nothing must be done that might render the generator in noncompliance with such codes, standards and instructions.
- The RV generator produces extremely high and dangerous electrical voltages and can cause dangerous, and possibly fatal, electrical shock. Avoid contact with bare wires, terminals, etc. while the unit is running. If you must work around an operating generator, stand on an insulated, dry surface to reduce shock hazard.
- Never work on this equipment or handle any electrical device while standing in water, while barefoot, or while hands or feet are wet. Dangerous electrical shock will result.
- Have the generator properly grounded (bonded) during installation onto the vehicle, either by solid mounting to the vehicle frame or chassis or by means of an approved bonding conductor. DO NOT disconnect the bonding conductor, if so equipped. DO NOT reconnect the bonding conductor to any generator part that might be removed or disassembled during routine maintenance. If the grounding conductor must be replaced, use only a flexible conductor that is of No. 8 AWG copper wire minimum.
- Inspect the generator periodically. Repair or replace all damaged or defective parts immediately.
- In case of accident caused by electric shock, shut down the source of electrical power down at once. If this cannot be done, free victim from live conductor. AVOID DIRECT CONTACT WITH THE VICTIM. Use a dry board, dry rope, or other non-con-

ducting implement to free the victim from live conductor. If victim is unconscious, apply CPR (cardiopulmonary resuscitation) and get medical help.

- Inspect fuel system frequently for leaks or damage. Repair or replace any damaged or leaking component immediately. Never attempt to change, alter or modify the generator fuel system in any way that might affect safety or compliance with applicable codes and standards.
- The generator engine gives off DEADLY carbon monoxide gas through its exhaust system. This dangerous gas, if breathed in sufficient concentrations, can cause unconsciousness or even death. This exhaust system must have been properly installed, in strict compliance with applicable codes and standards. Following installation, you must do nothing that might render the system unsafe or in non-compliance with such codes and standards. The generator compartment must be completely vapor sealed from vehicle interior. There must be no possibility of exhaust fumes entering the vehicle interior. Never operate this equipment with a leaking or defective exhaust system.
- Never use the generator or any of its parts as a step. Stepping on the unit can stress and break parts and may result in dangerous operating conditions from leaking exhaust gases, fuel leakage, oil leakage, coolant leakage, etc.
- Do not smoke around the generator. Wipe up any fuel, oil and coolant spills immediately. Never leave oily or fuel soaked rags in the generator compartment or on the generator itself. Keep the area around the generator clean and free of debris.
- Adequate ventilation is required to expel toxic fumes and gasoline vapors from the generator compartment. Do not alter the installation of this equipment in any manner that might obstruct air and ventilation openings. Such openings must be kept clear and unobstructed.
- Keep hands, feet, clothing, etc., away from drive belts, fans and other moving parts of this equipment. Never remove any drive belt or fan guards while the unit is operating.
- Some generators may use LP gas (propane) as a fuel. LP gas is highly EXPLOSIVE. The gas is heavier than air and tends to settle in low areas where even the slightest spark can ignite the gas and cause an explosion.
- Before performing any maintenance on the generator set, disconnect its battery cables to prevent accidental start up. Disconnect the cable from the battery post indicated by a NEGATIVE, NEG or (-) first. Reconnect that cable last.



## WARNING:



The engine exhaust from this product contains chemicals known to the State of California to cause cancer, birth defects, or other reproductive harm.

# IDENTIFICATION RECORD

Please record the following information, from the generator DATA PLATE or information decal:

1. Model Number \_\_\_\_\_
2. Serial Number \_\_\_\_\_
3. kW Rating \_\_\_\_\_
4. Rated Voltage \_\_\_\_\_
5. Phase \_\_\_\_\_
6. Hertz \_\_\_\_\_

MODEL	<input type="text"/>	VOLTS	<input type="text"/>
SERIES	<input type="text"/>	AMPS	<input type="text"/>
SERIAL	<input type="text"/>	VATTS	<input type="text"/>

PHASE-1 HERTZ-60 RPM-VARIABLE  
CLASS F INSULATION AT 40°C CONTINUOUS DUTY  
FOR SERVICE CENTER LOCATIONS  
CALL 800-333-1322 — 24 HOURS A DAY  
GENERAC CORPORATION  
WAUKESHA, WIS  
MADE IN U.S.A.  
U.S. AND FOREIGN PATENTS PENDING

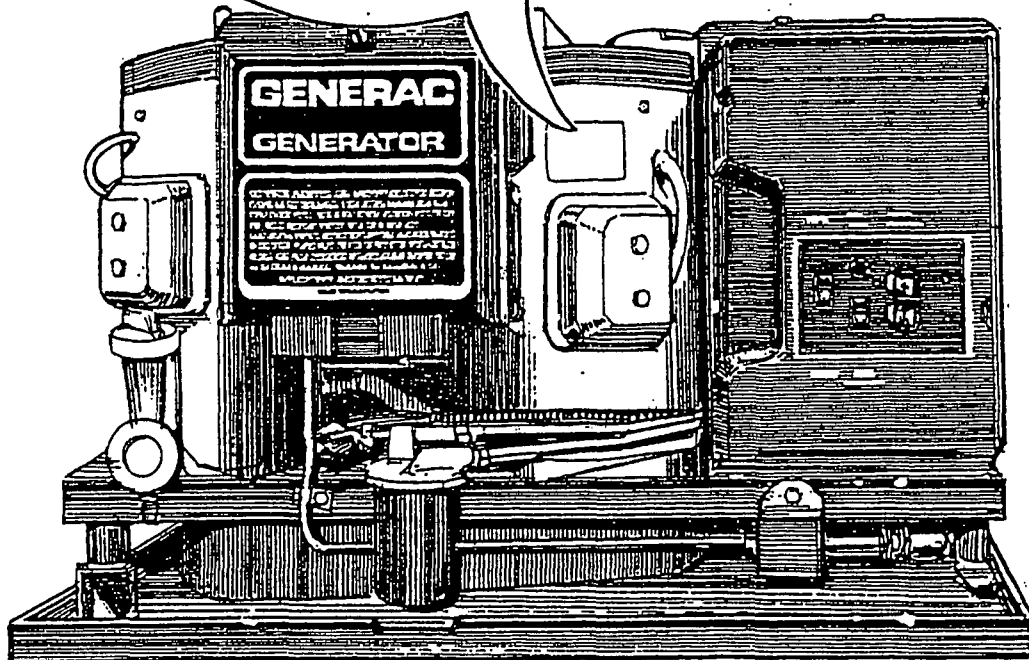

# TABLE OF CONTENTS

<b>GENERAL SAFETY RULES.....inside cover</b>		<b>SPECIFICATIONS</b>	
<b>IDENTIFICATION RECORD..... 1</b>		Fuel Requirements .....10	
<b>READ THIS MANUAL THOROUGHLY ..... 3</b>		Engine Oil Requirements.....10	
Operation and Maintenance ..... 3		Generator Specifications .....10	
How to Obtain Service..... 3		Engine Specifications .....10	
<b>GENERATOR FEATURES ..... 4</b>		<b>MAINTENANCE</b>	
<b>GENERATOR FAMILIARIZATION</b>		Checking Engine Oil Level .....11	
Generator Applicability ..... 5		Change Engine Oil.....11	
Installation ..... 5		Change Oil Filter.....11	
Safety 5		Engine Air Cleaner.....12	
Generator AC Connection System..... 5		Spark Arrestor Muffler.....12	
<b>OPERATING INSTRUCTIONS</b>		Engine Spark Plugs .....12	
Generator Control Panel ..... 6		Fuel Filter.....12	
Automatic Choke ..... 6		<b>MISCELLANEOUS MAINTENANCE</b>	
Before Starting the Engine ..... 6		Cleaning the Generator .....13	
Starting ..... 7		Battery 13	
Stopping the Generator ..... 7		Service and Adjustments .....13	
Applying Loads to Generator..... 7		Throttle Linkage Adjustment.....13	
Operation in High Grass or Brush ..... 7		Adjusting the Carburetor.....14	
Don't Overload the Generator ..... 8		Major Service Manual .....14	
Wattage Reference Guide..... 8		Exercising the Generator .....15	
<b>ENGINE PROTECTIVE DEVICES</b>		Out of Service Protection.....15	
Automatic Low Oil Pressure Shutdown..... 9		Return the Unit to Service after Storage.....15	
High Temperature Shutdown ..... 9		<b>TROUBLESHOOTING.....16</b>	
Overspeed..... 9		<b>ELECTRICAL DATA .....17</b>	
Low Voltage..... 9		<b>REPAIR PARTS ..... 18 to 25</b>	
		<b>WARRANTY ..... back page</b>	

# READ THIS MANUAL THOROUGHLY

If you don't understand any portion of this manual, contact Generac for a demonstration of actual starting, operating and servicing procedures.

Throughout this publication and on tags and decals affixed to the generator, DANGER and CAUTION blocks are used to alert you to special instructions about a particular operation that may be hazardous if performed incorrectly or carelessly. Observe them carefully.

These safety warnings cannot eliminate the hazards that they indicate. Strict compliance with the special instructions while performing the service plus "common sense" are major measures to prevent accidents.

The following definitions apply to DANGER, CAUTION and NOTE blocks found throughout the manual.

 **DANGER: AFTER THIS HEADING YOU CAN READ HANDLING, INSTALLING, OPERATING OR SERVICING INSTRUCTIONS THAT, IF NOT STRICTLY COMPLIED WITH, MAY RESULT IN PERSONAL INJURY.**

**CAUTION:** After this heading you can read instructions for handling, installing, operating or servicing the generator that, if not strictly complied with, may result in damage to equipment and/or property.

**NOTE:** After this heading you can read explanatory statements that require special emphasis.

These symbols indicate the following:

 Points out important safety information and, if not followed, could endanger personal safety and/or property of yourself and others.

 Potential explosion hazard

 Potential fire hazard

 Potential electrical shock hazard

The operator (driver) is responsible for proper and safe use of the vehicle, equipment on the vehicle, and the safety of all vehicle occupants. We strongly recommend that the operator read this Owner's Manual and thoroughly understand all instructions before using this equipment. We also strongly recommend instructing other occupants in the vehicle to properly start and operate the generator. This prepares them if they need to operate the equipment in an emergency.

## OPERATION AND MAINTENANCE

It is the operator's responsibility to perform all safety checks; to make sure that all maintenance for safe operation is performed promptly; and to have the equipment checked by an Authorized Dealer periodically. Normal maintenance service and replacement of parts are the responsibility of the Owner/Operator and, as such, are not considered defects in materials or workmanship within the terms of the warranty. Individual operating habits and usage contribute to the need for maintenance service.

Proper maintenance and care of your industrial mobile generator assures a minimum number of problems and keeps your operating expenses at a minimum. See your authorized Dealer/Distributor for service aids and accessories.

## HOW TO OBTAIN SERVICE

When your industrial mobile generator set requires servicing or repairs, simply contact an Authorized Service Station for assistance. Service technicians are factory-trained and are capable of handling all of your service needs.

When contacting an Authorized Service Facility or the factory about parts and service, always supply the complete model number and serial number of your unit as given on its data plate.

The warranty on your generator is included in this Owner's Manual, as well as listings for repair parts.

# GENERATOR FEATURES

---

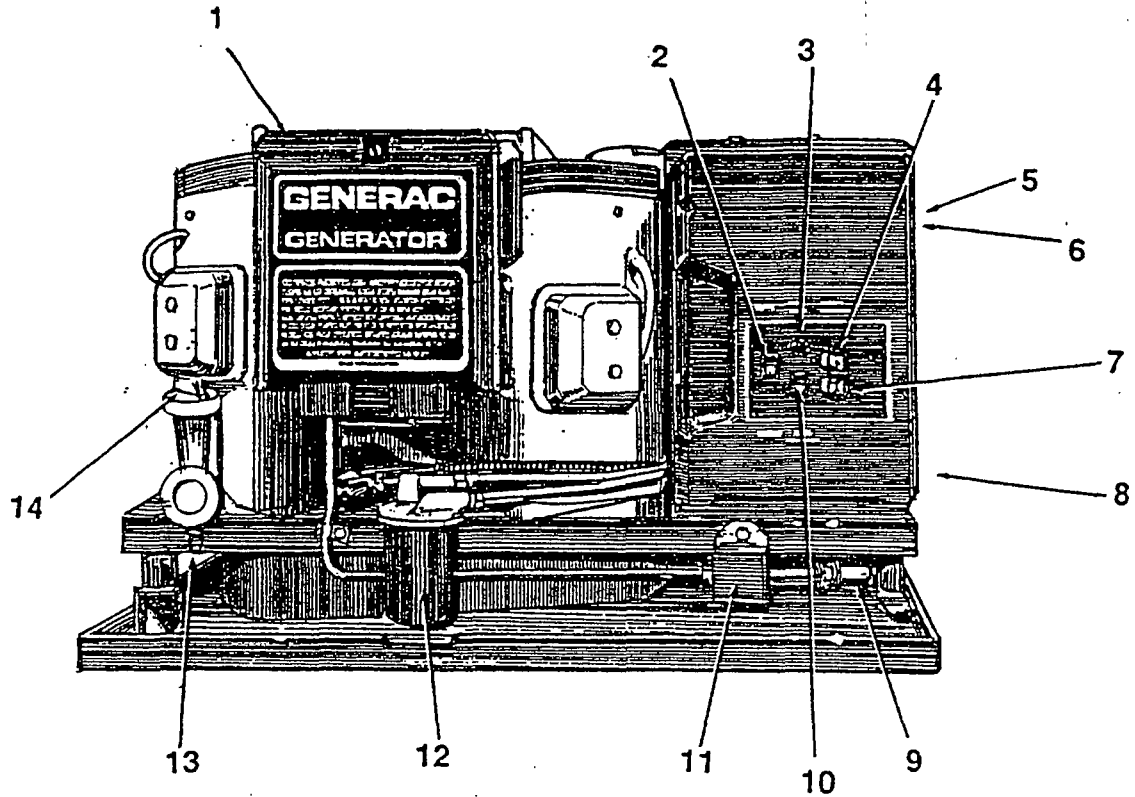

## REFERENCE NUMBER IDENTIFICATION

- |                                     |                                  |
|-------------------------------------|----------------------------------|
| 1. Generator Air Intake Screen      | 8. Starter Contactor             |
| 2. Engine Start/Stop Switch         | 9. Fuel Inlet                    |
| 3. 15 amp Fuse                      | 10. Fuel Pump Primer Switch      |
| 4. 30 amp Circuit Breaker           | 11. Fuel Pump                    |
| 5. Optional Remote Panel Receptacle | 12. Oil Filter                   |
| 6. Generator AC Output Leads        | 13. Oil Drain Plug               |
| 7. 30 amp Circuit Breaker           | 14. Oil Dipstick and Filler Tube |

# GENERATOR FAMILIARIZATION

## GENERATOR APPLICABILITY

The NP-66G generator has been designed and manufactured for supplying electrical power for recreational vehicles. You should not modify the generator or use it for any application other than for what it was designed. If there are any questions pertaining to its application, write or call the factory. Do not use the unit until you have been advised by competent authority.

**⚠ DANGER: FOR FIRE SAFETY, THE GENERATOR MUST HAVE BEEN PROPERLY INSTALLED IN COMPLIANCE WITH (1) ANSI 119.2-1975/NFPA 501C-1974 "STANDARD FOR RECREATIONAL VEHICLES", PART III, "INSTALLATION OF ELECTRICAL SYSTEMS." THE GENERATOR ALSO MUST HAVE BEEN INSTALLED IN STRICT COMPLIANCE WITH THE MANUFACTURER'S DETAILED INSTALLATION INSTRUCTIONS. AFTER INSTALLATION, DO NOTHING THAT MIGHT RENDER THE UNIT IN NON-COMPLIANCE WITH SUCH CODES, STANDARDS AND INSTRUCTIONS.**

You can use your generator set to supply electrical power for operating 120 and/or 240 volts, single phase, 60 Hz electrical loads. These loads can require up to 6600 watts (6.6 kW) of power, but cannot exceed 55 AC amperes of current at 120 volts or exceed 27.5 AC amperes at 240 volts.

**CAUTION:** Do not overload the generator. Some installations may require that electrical loads be alternated to avoid overloading. Applying excessively high electrical loads may damage the generator and may shorten its life. Add up the rated watts of all electrical lighting, appliance, tool and motor loads the generator will power at one time. This total should not be greater than the wattage capacity of the generator. If an electrical device nameplate gives only volts and amps, multiply volts times amps to obtain watts (volts x amps = watts). Some electric motors require more watts of power (or amps of current) for starting than for continuous operation.

## INSTALLATION

This Owner's Manual has been prepared under the assumption that a competent, qualified technician installed the generator into an industrial vehicle. We also assume the installer complied with all applicable codes, standards and regulations pertaining to installation.

An INSTALLATION MANUAL was shipped with the generator. That Manual contains manufacturer's instructions and recommendations for installing the unit into an industrial vehicle. After installation, installers should forward the Installation Manual to Owners/Operators for their information.

Owners/Operators have the responsibility to make sure that nothing is done that might render the installation unsafe or in non-compliance with applicable codes, standards and instructions.

## SAFETY

Before using the generator set, carefully read GENERAL SAFETY RULES inside the cover. Comply with these RULES to prevent accidents and damage to equipment and/or property. Generac suggests copying and posting the GENERAL SAFETY RULES to potential operators of this equipment.

## GENERATOR AC CONNECTION SYSTEM

These air-cooled NP Series generator sets are equipped with dual stator AC power windings. These two stator windings supply electrical power to customer electrical loads by means of a dual 2-wire connection system.

The generator may have been installed so that units only power 120 volts AC loads (Figure 1); or you can wire them to connect both 120 and/or 240 volts AC electrical loads. Be sure to remove the jumper between the circuit breakers when connecting for 120/240 volts.

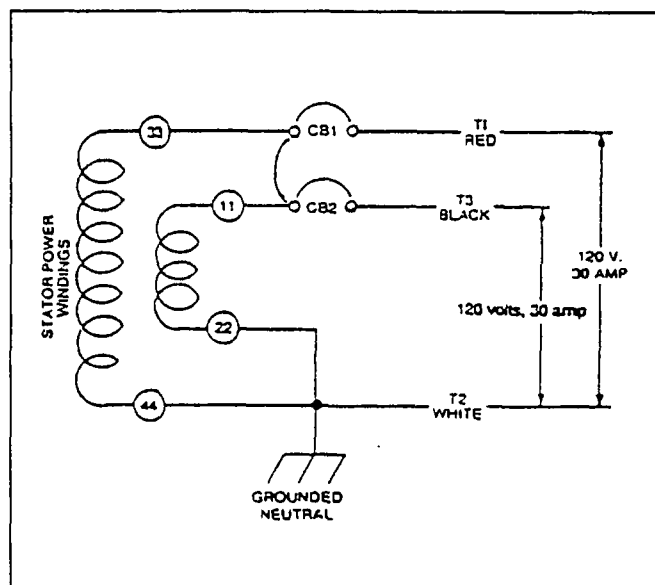

Figure 1 — Connection for 120 Volts Only

# OPERATING INSTRUCTIONS

## GENERATOR CONTROL PANEL

Mounted on the generator control panel (Figure 2) are the following features:

- **Fuel Pump Primer:** Before starting a cold engine (it has not been started in more than two weeks), you must press this switch to bring fuel from the tank to the fuel pump. This rocker type switch springs back into its original position when you release it.
- **Start/Stop Switch:** To crank and start the engine, hold this switch at its START position. Release the switch when the engine starts. To stop an operating engine, place the switch in its STOP position. The switch center position is the RUN position.
- **15 amp Fuse:** Protects the engine DC control circuit against electrical overload. If the fuse element has melted open due to overloading, the engine cannot be cranked. If you must replace it, use only an identical 15-amp replacement fuse.
- **Line Breakers:** Protects generator's AC output circuit against overload, i.e., prevents unit from exceeding wattage/ampere capacity. NP-66G has one 20-amp and one 30-amp breaker.

**NOTE:** If the SeriesQ-66G has been reconnected for dual voltage AC output (120/240 volts), you can install line breakers having an amperage rating that is different than stated above. The replacement line breakers consist of two separate breakers with a connecting piece between the breaker handles (so that both breakers will operate at the same time). If the unit is reconnected for dual voltage, it is no longer RVIA listed.

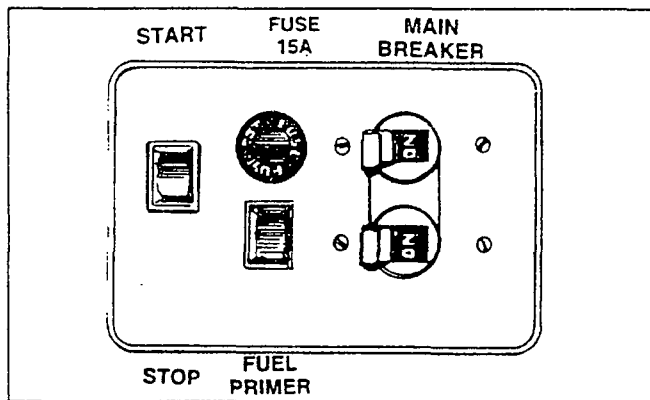

Figure 2 — Typical Control Panel

## OPTIONAL REMOTE START/STOP PANEL

Optional remote mounted panels are available which permit you to crank and start the generator from any convenient location in the recreational vehicle. Figure 3 shows the Model 9042 remote panel which includes (a) start/stop switch and (b) a generator run lamp.

You can also order Model 9043, a remote panel which includes the (a) start/stop switch, (b) the generator run lamp and (c) an hourmeter. The hourmeter provides a continuous indication of engine-generator operating time. Use the hourmeter for checking off periodic maintenance requirements on the unit.

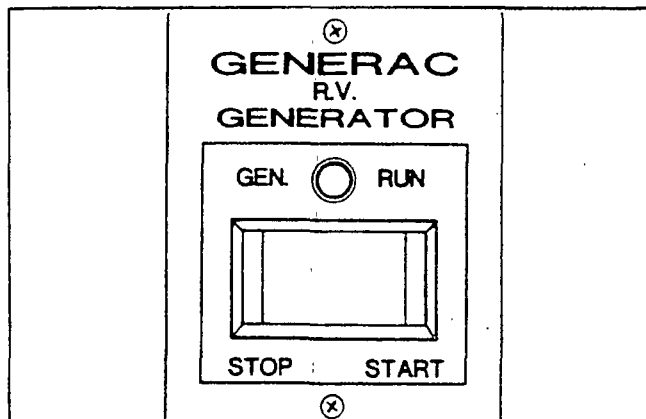

Figure 1 — Optional Remote Panel (Model 9042)

## AUTOMATIC CHOKE

The engine is equipped with an automatic choke that consists of two main components — choke solenoid and prechoke.

**Choke Solenoid:** During engine cranking (start/stop switch at START), a solid state choke module signals the choke solenoid to actuate and cycle (choke on/choke off) until engine starts. The choke solenoid thus opens and closes the carburetor choke valve only when the engine is cranking. When the engine starts, the choke cycling stops.

**Prechoke:** The choke system also has a temperature sensitive metal strip that adjusts the choke valve angle according to ambient temperatures (i.e. in cold ambient temperatures the choke valve closes more). Once the engine starts, an element heats the temperature-sensitive strip to a normal operating condition, opening the choke valve. This may take about 3 minutes in cooler weather.

## BEFORE STARTING THE ENGINE

**IMPORTANT:** INSTRUCTIONS AND INFORMATION IN THIS MANUAL ASSUME THE GENERATOR HAS BEEN PROPERLY INSTALLED, CONNECTED, SERVICED, TESTED AND ADJUSTED BY A QUALIFIED INSTALLATION TECHNICIAN OR INSTALLATION CONTRACTOR.

- **Installation:** Generator installation must have been properly completed so it complies with all applicable codes, standards and regulations and with the manufacturer's recommendations.
- **Engine Lubrication:** Have engine crankcase properly serviced with recommended oil before starting. Refer to "Maintenance" and "Specifications" sections for oil servicing procedures and recommendations.

**CAUTION:** Any attempt to crank or start the engine before you have properly serviced it with the recommended oil will result in an engine failure.



- **Fuel Supply:** The engine must have adequate supply of proper fuel to operate. Before starting, check that sufficient fuel is available.
- **NOTE:** On some installations, the generator engine may "share" the vehicle's gasoline fuel tank with vehicle engine. Some installations may provide separate fuel tanks for generator and vehicle engine.
- **Cooling and Ventilating Air:** Air inlet and outlet openings in the generator compartment must be open and unobstructed for continued proper operation. Without sufficient cooling and ventilating air flow, the engine-generator quickly overheats which causes it to quickly shutdown. Overheating could also damage the unit or your vehicle.
- **Engine Exhaust Gases:** Before starting the generator engine, you should be sure there is no way for exhaust gases to enter the vehicle interior and endangering people or animals. Close windows, doors and other openings in the vehicle that, if open, might permit exhaust gases to enter the vehicle.

**⚠ DANGER: THE GENERATOR ENGINE GIVES OFF DEADLY CARBON MONOXIDE GAS THROUGH ITS EXHAUST SYSTEM. THIS DANGEROUS GAS, IF BREATHED IN SUFFICIENT CONCENTRATIONS, CAN CAUSE UNCONSCIOUSNESS OR EVEN DEATH. DO NOT OPERATE THE GENERATOR IF ITS EXHAUST SYSTEM IS LEAKING OR HAS BEEN DAMAGED. SYMPTOMS OF CARBON MONOXIDE POISONING ARE (A) INABILITY TO THINK COHERENTLY, (B) VOMITTING, (C) TWITCHING MUSCLES, (D) THROBING TEMPLES, (E) DIZZINESS, (F) HEADACHE, (G) WEAKNESS AND SLEEPINESS. IF YOU FEEL ANY OF THESE SYMPTOMS, MOVE INTO FRESH AIR IMMEDIATELY. IF SYMPTOMS PERSIST, GET MEDICAL HELP.**

## STARTING

**IMPORTANT:** Read the vehicle manufacturer's instructions. The owner/operator should become familiar with the vehicle in which this generator is installed. Differences exist between vehicles. For example, some vehicles may use a transfer switch to isolate dockside power from the generator, while other vehicles may use an isolating receptacle. Some vehicles may be equipped with a DC converter which allows the generator to power certain DC lighting and other DC loads.

To crank and start the generator engine, proceed as follows:

1. Turn OFF electrical loads, using whatever means provided in your vehicle (such as a main line circuit breaker or transfer switch).

**NOTE:** If you start the engine with start/stop switch on the generator control panel, turn OFF loads by setting the panel's main breakers to their "OFF" or "OPEN" positions. Electrical load circuits will be turned ON after the generator has started, stabilized and warmed up.

2. If you have not started the engine in more than two weeks, press the Fuel Pump Primer switch and hold it for about 30 seconds to activate the automatic shut-off function. However, if the engine is warm, skip Step 2.
3. To crank and start the engine, hold the start/stop switch at START. Release the switch when the engine starts.

**CAUTION:** If the engine does not start after it has been cranking for 15 seconds, release the start/stop switch and try again. Holding the switch for longer than 15 seconds can damage the starter motor.

4. Let the engine run at no-load for a few minutes to stabilize and warm up the engine.
5. Turn ON electrical loads, using whatever means provided (such as a main circuit breaker or transfer switch).

**NOTE:** If you start a warm generator engine, you may only press the start switch slightly to engage the ignition system. However, you should press and hold the starter switch for a minimum of two seconds to energize the field boost system. If you start the engine without energizing the field boost system, the generator produces no AC output.

## STOPPING THE GENERATOR

1. Turn OFF all electrical loads, using whatever means provided (such as a main circuit breaker or transfer switch).
2. Let the generator run at no-load for a few minutes, to stabilize internal engine-generator temperatures.
3. Press STOP on the start/stop switch. The engine will come to complete stop.

## APPLYING LOADS TO GENERATOR

When applying electrical loads to the generator, observe these guidelines:

- Before applying electrical loads, let the generator stabilize and warm up for a minute or two.
- DO NOT overload the generator.

**Letting Engine Stabilize:** The generator supplies correct rated frequency and voltage only at the proper governed speed. Some electrical appliances may be extremely sensitive to voltage and frequency. Incorrect frequencies and/or voltages can damage those appliances.

If electrical loads are applied at reduced operating speeds, such loads imposed on the engine when sufficient power is not available may shorten engine life. Never turn ON electrical loads until after the generator engine has started and stabilized ON-speed.

**Do Not Overload the Generator:** You can read the rated wattage/amperage capacity of your generator on the generator data plate (see "Identification Record" on Page 1).

Applying electrical loads in excess of the unit's rated capacity can burn out the unit and anything connected to it. Also, overloading trips main circuit breakers.

To avoid overloading, add up the wattage of all connected electrical lighting, appliance, tool and motor loads. This total should not be greater than the generator's rated wattage capacity.

- Most lighting, appliance, tool and motor loads indicate their required watts on their nameplate or data plate. For light bulbs, simply note the wattage rating of the bulb.

- If a load does not show its rated wattage, multiply that load's rated VOLTS times AMPS to obtain WATTS.
- Induction type motors (such as those that run the vehicle's furnace fan, refrigerator, air conditioner, etc.) need about 2-1/2 times more watts of power for starting than for running (for a few seconds during motor starting). Be sure to allow for this when connecting electrical loads to the generator. First, figure the watts needed to start electric motors in the system. To that figure, add the running wattages of other items that will be operated by the generator.
- Do not apply heavy electrical loads for the first two or three hours of operation.

### WATTAGE REFERENCE GUIDE

	RUNNING WATTS		RUNNING WATTS
*Air Conditioner (12,000 Btu).....	1700	Lawn Mower.....	1200
Battery Charger (20 amp).....	500	Light Bulb.....	100
Belt Sander (3").....	1000	Microwave Oven.....	700
Chain Saw.....	1200	*Milk Cooler.....	1100
Circular Saw (6-12").....	800 to 1000	Oil Burner on Furnace.....	300
Coffee Maker.....	1000	Oil Fired Space Heater (140,000 Btu).....	400
*Compressor (1 HP).....	2000	Oil Fired Space Heater (85,000 Btu).....	225
*Compressor (3/4 HP).....	1800	Oil Fired Space Heater (30,000 Btu).....	150
*Compressor (1/2 HP).....	1400	*Paint Sprayer, Airless (1/3 HP).....	600
Curling Iron.....	700	Paint Sprayer, Airless (handheld).....	150
*Deep Freeze.....	500	Radio.....	50 to 200
Disc Sander (9").....	1200	*Refrigerator.....	600
Edge Trimmer.....	500	Slow Cooker.....	200
Electric Nail Gun.....	1200	*Submersible Pump (1-1/2 HP).....	2800
Electric Range (one element).....	1500	*Submersible Pump (1 HP).....	2000
Electric Skillet.....	1250	*Submersible Pump (1/2 HP).....	1500
*Furnace Fan (1/3 HP).....	1200	Sump Pump.....	600
Hair Dryer.....	1200	*Table Saw (10").....	1750 to 2000
Hand Drill (1").....	1100	Television.....	200 to 500
Hand Drill (1/2").....	750 to 1000	Weed Trimmer.....	500
Hand Drill (3/8").....	500		
Hand Drill (1/4").....	250		
Hedge Trimmer.....	450		
Impact Wrench.....	500		
*Jet Pump.....	800		

\* Allow 2-1/2 times the listed watts for starting these devices.

## ADDITIONAL INFORMATION

This section discusses some of the engine protective devices, overload protection and breaking in a new generator.

### AUTOMATIC LOW OIL PRESSURE SHUTDOWN

The engine is equipped with a normally-open (N.O.) oil pressure switch (Figure 4). Engine oil pressure holds the switch open during cranking and operation. Should oil pressure drop below about 2-6 PSI, the switch contacts close and the engine automatically shuts down.

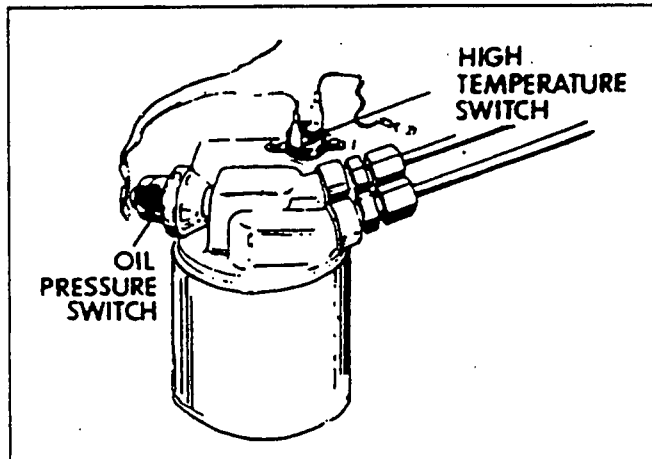

Figure 4 — Switches for Engine Safety Shutdown

### HIGH TEMPERATURE SHUTDOWN

An oil temperature switch (Figure 4) with normally-open (N.O.) contacts is mounted near the oil filter. If oil temperature were to exceed about 284°F (140°C), the switch contacts close and the engine shuts down.

### FIELD BOOST

The Controller Circuit Board houses a field boost diode and resistor which are not part of the automatic choke circuit. These two components are part of a "field boost" circuit (Figure 5). During engine cranking only, a positive DC (battery) voltage is delivered through the diode, resistor, brushes and slip rings, and to the generator rotor. Application of this voltage to the rotor "flashes the field" whenever it is started. Flashing of the field each time the generator starts makes sure that a sufficiently strong magnetic field is available to produce the required "pick up" voltage in the stator windings.

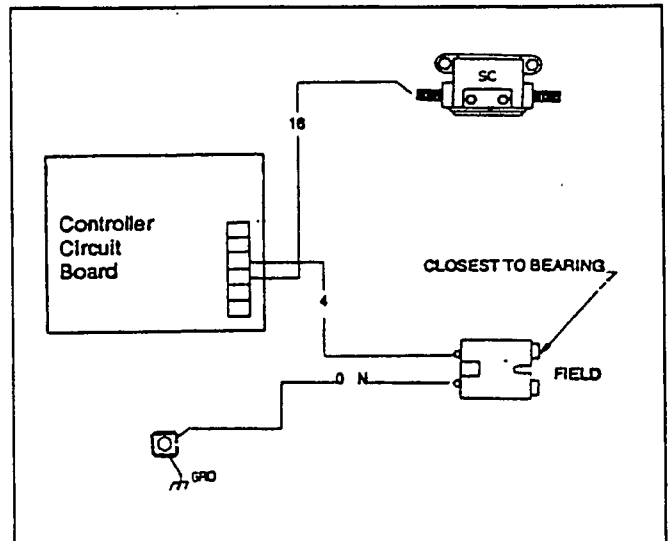

Figure 5 — Field Boost Circuit

### OVER VOLTAGE PROTECTION

A solid state voltage regulator (Figure 6) controls the generator's AC output voltage. This regulator supplies an excitation current to the rotor. By regulating the rotor's excitation current, the strength of its magnetic field is regulated and, in turn, the voltage delivered to connected electrical loads is controlled. When the AC frequency is 50 Hz, voltage is regulated at 120 volts (voltage-to-frequency ratio is 2-to-1).

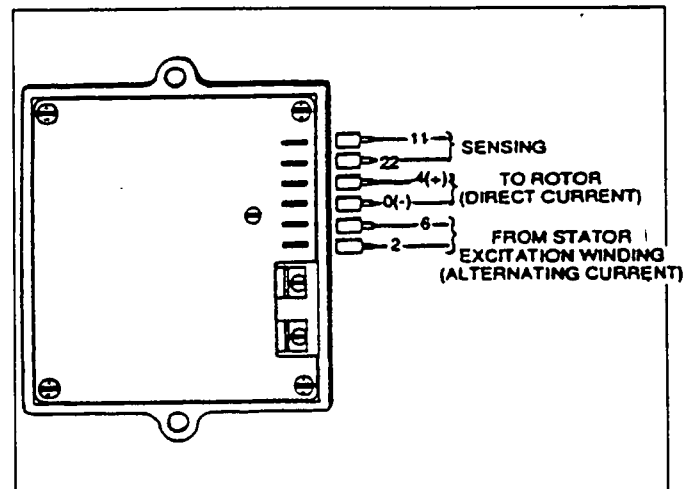

Figure 6 — Solid State Voltage Regulator

The voltage regulator also incorporates a "voltage surge protection circuit." This circuit prevents troublesome surges in the generator AC output voltage. Voltage surge is a common cause of damage to electronic equipment.

## **25-HOUR BREAK IN PERIOD**

The first 25 hours of operation are for "breaking in" the new generator. Correctly breaking in the generator is essential to minimize fuel consumption and provide maximum engine performance. During this 25-hour break in period, comply with the following:

- Run the unit at varying electrical loads, to help seat engine piston rings properly.
- For the 75 hours of operation after the "break in" period, avoid light electrical loads. Load the generator at 50% (or more) of its rated wattage capacity. Repeated light loads during the break in period can cause improper seating of engine piston rings, which could cause blowby and high oil consumption.
- During the break in period, check engine oil level frequently. It is normal for oil consumption to be high during the breaking in period.
- After the 25-hour break-in period, complete the tasks recommended under "25-Hour Check Up."

## **25-HOUR CHECK UP**

After the 25-hour break-in period, contact an authorized service facility for the following maintenance. The vehicle owner is responsible for any charges:

- Change engine crankcase oil and oil filter.
- Check all fluid levels.
- Inspect cooling and ventilation openings on the vehicle.
- Check engine carburetor adjustments.
- Check engine ignition system.
- Inspect entire electrical system.
- Inspect the engine exhaust system.

## **OPERATION IN HIGH GRASS OR BRUSH**

Never operate the generator while the vehicle is parked in high grass, weeds, brush or leaves. Such materials can ignite and burn from the heat of the exhaust system. The generator exhaust system becomes extremely hot during operation and remains hot for a long time after it has shut down.

# SPECIFICATIONS

## GENERATOR SPECIFICATIONS

Rated Maximum Continuous  
AC Output ..... 6600 watts (6.6 kW)  
Rated Voltage ..... 120 Volts AC\*  
Rated Maximum Continuous  
AC Current at 120 volts ..... 55 AC amperes $\Delta$   
Phase ..... 1  
Rated AC Frequency ..... 60 Hertz  
Driven Speed of Rotor ..... 3600 RPM  
Rotor Poles ..... 2  
\* All units are reconnectable to 120/240 volts (dual voltage) output. Units are not listed per RVIA/ANSI when reconnected for dual voltage output.  
 $\Delta$  Rated maximum continuous current at 240 volts is 27.5 amperes.

## ENGINE SPECIFICATIONS

Type of Engine ..... Twin Cylinder  
Cooling Method ..... Air-cooled  
Rated Horsepower ..... 16 at 3600 rpm  
Displacement ..... 480cc  
Compression Ratio ..... 8.6 to 1  
Cylinder Block ..... Aluminum with cast iron sleeve  
Type of Governor ..... Mechanical, fixed speed  
Engine Governed Speed ..... 2571 rpm  
Air Cleaner ..... Paper element with foam pre-cleaner  
Starter ..... 12 volts DC electric  
Ignition System ..... Solid state with flywheel magneto  
Recommended Spark Plugs  
Champion ..... RC12YC  
AC ..... R45S  
Fram Autolite ..... 65  
Spark Plug Gap ..... 0.030 inch (0.8mm)

## FUEL REQUIREMENTS

The NP-66G generator is equipped with a gasoline fuel system as standard equipment. Specific installations may provide either a separate fuel tank for the generator, or the generator may "share" the vehicle engine's fuel tank.

**NOTE:** Some installations using a "shared" fuel tank may have a generator fuel pickup tube that is shorter than the vehicle engine's pickup tube. Such an arrangement causes the generator engine to "run out of gas" while adequate fuel in the vehicle remains in the tank.

To reduce lead and carbon deposits use high quality UNLEADED gasoline with the generator. Leaded REGULAR grade gasoline is an acceptable substitute.

**NOTE:** Using "Unleaded" gasoline contributes to longer engine valve life by reducing lead and carbon deposits.

**CAUTION:** Generac does not recommend using any gasoline containing alcohol (such as "gasohol"). If you use any gasoline containing alcohol, it must not contain more than 10 percent ethanol and it must be removed from the tank during storage. Do NOT use any gasoline containing methanol. If you use gasoline with alcohol, inspect more frequently for fuel leaks and other abnormalities.

## ENGINE OIL REQUIREMENTS

Use a high quality detergent oil classified "For Service SF" and with an oil viscosity rating of SAE 10W-30 oil. Do not pour in any additives to the recommended oil. Engine crankcase capacity is 1.5 U.S. quarts. See MAINTENANCE section for oil level check and filling procedures.

# MAINTENANCE

This section includes information about simple maintenance which includes the following tasks:

- Checking engine oil level.
- Changing engine oil.
- Changing oil filter.
- Changing the air cleaner.
- Cleaning the air intake screen.
- Cleaning spark plugs.

## CHECKING ENGINE OIL LEVEL

Check engine crankcase oil level at least every eight hours of operation, or before you use it (Figure 7).

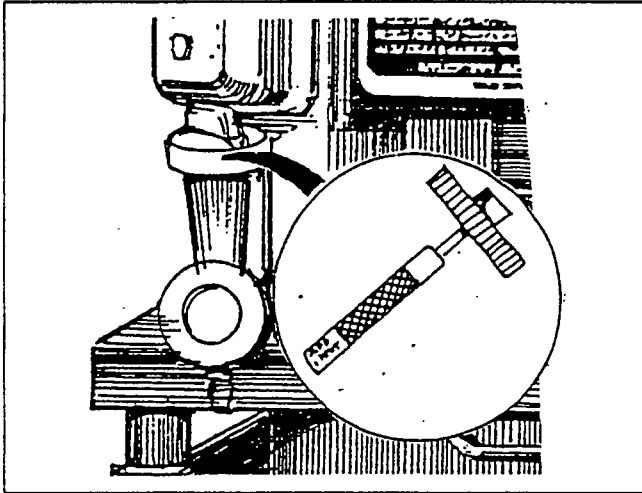

Figure 7 — Oil Dipstick and Fill Tube

- Be sure the generator is as level as possible.
- Remove oil dipstick and wipe dry with clean, lint-free cloth.
- Install and tighten oil dipstick, then remove again.
- Oil should be at dipstick FULL mark. If necessary, add the recommended oil to the FULL mark only. DO NOT OVERFILL ABOVE "FULL" MARK.
- Install and tighten oil dipstick cap before operating the engine.

**NOTE:** See "Engine Oil Requirements" on Page 11 for recommended oils.

## CHANGE ENGINE OIL

Change engine oil after the first 25 hours of operation (after the 25-hour break-in period, Page 10). Thereafter, change oil every 50 operating hours. Change oil more frequently if operating consistently under heavy load or at high ambient temperatures.

- Warm up engine for at least five minutes, then shut down.
- With engine still warm from running, remove oil drain plug (Figure 8). Drain oil completely into a suitable container.

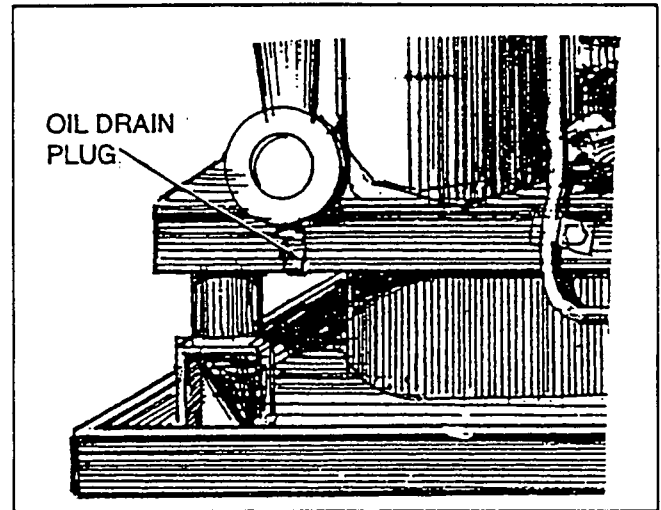

Figure 8 — Location of Oil Drain Plug

- When oil has drained, install and tighten oil drain plug.
- Remove oil dipstick and fill crankcase with the recommended oil (See Page 11). The engine crankcase can hold about 1.7 liters. DO NOT OVERFILL ABOVE "FULL" MARK.
- Install and tighten dipstick cap before operating engine.

## CHANGE OIL FILTER

Replace the engine oil filter after the first 25 hours of operation, every 100 operating hours thereafter.

- Turn oil filter counterclockwise to remove (Figure 9).
- Coat gasket of new filter with engine oil.
- Turn new filter clockwise until its gasket contacts tightly with the filter adapter. Then tighten with an additional 3/4 to one turn by hand.
- Run engine and check for leaks.

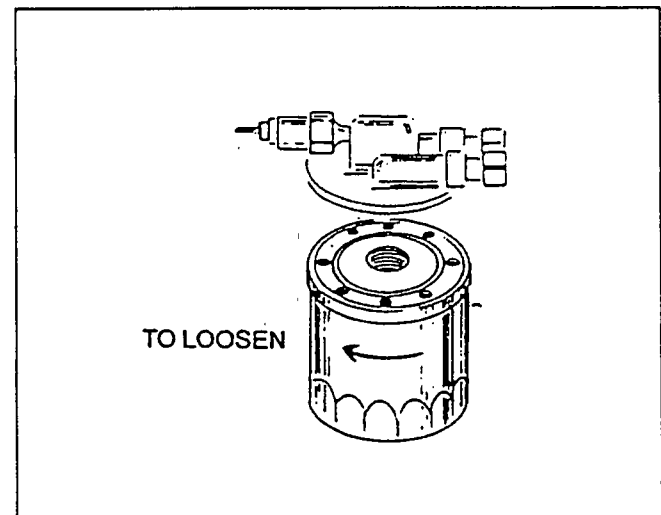

Figure 9 — Replacing Engine Oil Filter

## ENGINE AIR CLEANER

Clean and re-oil the foam pre-cleaner every three months or every 25 hours of operation, whichever occurs first. Service the foam pre-cleaner more frequently if you operate the generator in extremely dusty or dirty conditions (Figure 10):

- Turn KNOB counterclockwise to loosen.
- Remove COVER, FOAM PRE-CLEANER and PAPER FILTER.
- Remove foam pre-cleaner from cover.
- Wash foam pre-cleaner in liquid detergent and water.
- Wrap foam pre-cleaner in a cloth and squeeze dry.
- Saturate foam pre-cleaner in engine oil. Squeeze to remove excess oil and to distribute oil.
- Install foam pre-cleaner into cover, followed by paper filter. Tabs at edges of paper filter must lock into slots on cover.
- Insert bottom locking tag of cover into slot. Install cover, foam pre-cleaner and paper filter.

Once each year or every 100 operating hours (whichever comes first), replace the paper filter. The new replacement filter must be a flame retardant type.

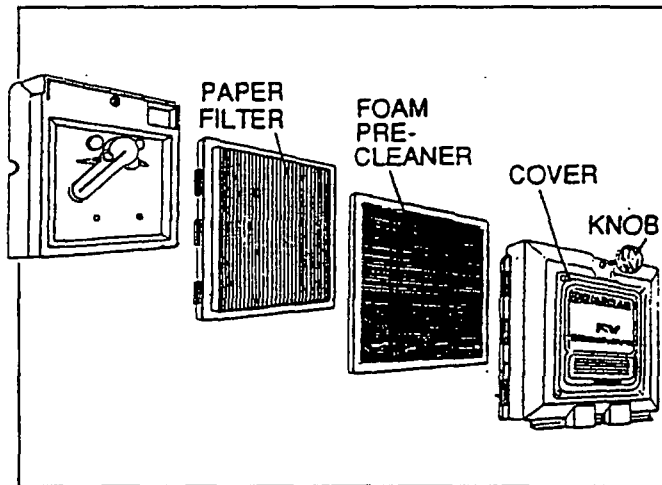

Figure 10 — Engine Air Cleaner

## CLEAN AIR INTAKE SCREEN

Clean all foreign material from the air intake screen (Figure 11) at least once every 100 hours of operation. Clean more often, if necessary.

Inspect the area around the generator exhaust muffler periodically and remove all grass, leaves, dirt, etc. from this area.

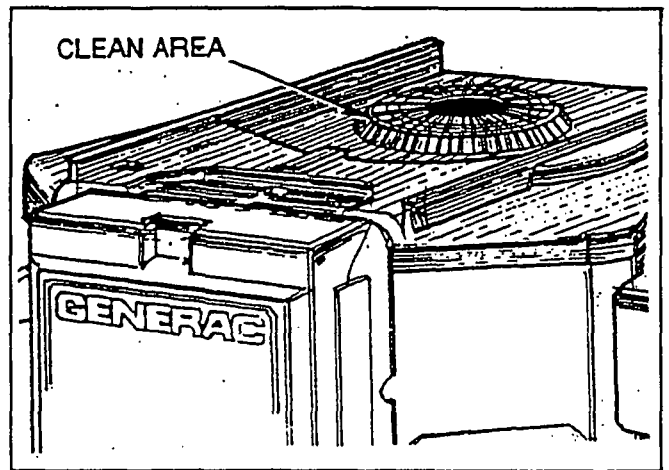

Figure 11 — Areas to Clean on Air Intake Screen

## ENGINE SPARK PLUGS

Clean engine spark plugs and reset gap to 0.030 inch (0.8mm) every 100 hours of operation (Figure 12). Clean by scraping or wire brushing and washing with commercial solvent. DO NOT BLAST CLEAN SPARK PLUGS.

**CAUTION:** Sparking can occur if wire terminals do not fit firmly over spark plug terminal ends. If necessary, reform wire terminals to obtain a tight fit.

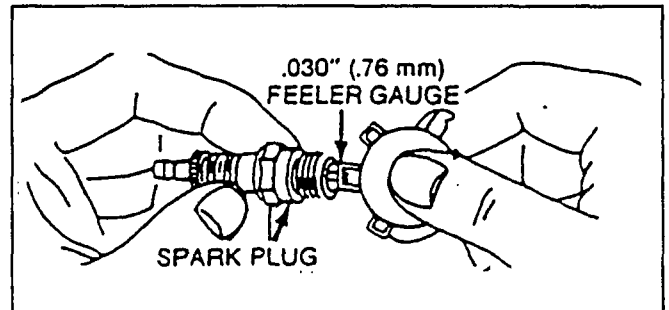
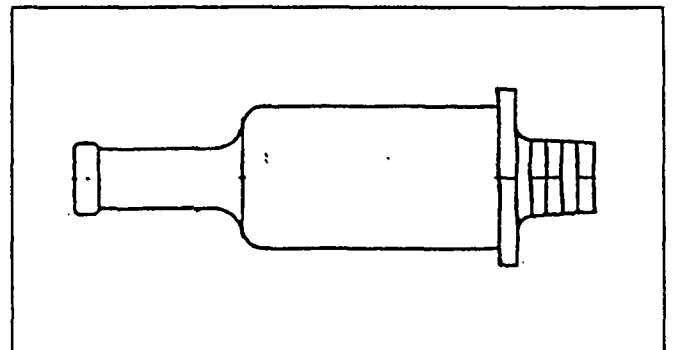

Figure 12 — Setting Spark Plug Gap

## FUEL FILTER

Remove and replace fuel filter (Figure 13) every 100 hours of operation or once each year, whichever comes



first.

Figure 13 — Fuel Filter

# MISCELLANEOUS MAINTENANCE

## SPARK ARRESTOR MUFFLERS

If the generator is not equipped with a spark arrestor exhaust muffler and is to be used on any forest covered, brush covered or grass covered unimproved land, you may have to install a spark arrestor. The spark arrestor must be maintained in effective working order by the vehicle owner/operator.

For assistance in ordering, installing and maintaining spark arrestor exhaust mufflers, contact your nearest authorized service facility.

Exhaust mufflers supplied by Generac are spark arrestor types. Generac exhaust mufflers for RV generators do not have a spark arrestor screen, but are of the more efficient "toroid" or "swirl" type. To remove carbon and combustion deposits from such mufflers, remove the PLUG from muffler and run engine for about 15 minutes. Shut engine down, let the muffler cool and install the plug.

 **WARNING: BE SURE TO RE-INSTALL THE PLUG FROM THE MUFFLER TIGHTLY. ENGINE VIBRATION COULD CAUSE A LOOSE PLUG TO FALL OUT. WITHOUT THE PLUG IN PLACE, HOT ENGINE EXHAUST IS DIRECTED OUT THE OPENING. THIS HOT EXHAUST, DEPENDING ON THE INSTALLATION, COULD BE DIRECTED TO AREAS NOT ABLE TO WITHSTAND THE EXTREME HEAT SUCH AS WOODEN FLOOR BOARDS OR OTHER FLAMMABLE MATERIALS. THIS COULD RESULT IN A FIRE.**

## CLEANING THE GENERATOR

Keep your generator set as clean and dry as possible. Dirt and moisture that are permitted to accumulate on electrical windings have an adverse affect on the insulation resistance of those windings.

Moisture that is allowed to remain in contact with windings will be retained in voids and cracks of the windings. Dirt makes the problem worse, since it tends to hold the moisture into contact with the windings. Salt, as from sea air, worsens the problem since it tends to absorb moisture from the air. The combination of salt and moisture makes a good electrical conductor.

**CAUTION!** Do NOT use a forceful spray of water to clean the generator. Water will enter the generator interior and cause problems, and may also contaminate the generator fuel system.

## BATTERY

All lead-acid storage batteries will discharge when not in use. The generator battery should be inspected as follows:

**Once Weekly:** Inspect battery posts and cables for tightness, corrosion. Clean and/or tighten as needed.

Also check battery fluid level, and, if necessary, fill with **DISTILLED WATER ONLY. DO NOT USE TAP WATER IN BATTERY.**

**Every Six Months:** Have battery state of charge and condition checked by automotive service facility. This should be done with automotive type battery hydrometer.

 **DANGER: STORAGE BATTERIES GIVE OFF EXPLOSIVE HYDROGEN GAS. THIS GAS CAN FORM AN EXPLOSIVE MIXTURE AROUND THE BATTERY FOR SEVERAL HOURS AFTER CHARGING. THE SLIGHTEST SPARK CAN IGNITE THE GAS AND CAUSE AN EXPLOSION. SUCH AN EXPLOSION CAN SHATTER THE BATTERY AND CAUSE BLINDNESS OR OTHER INJURY. ANY AREA THAT HOUSES A STORAGE BATTERY MUST BE PROPERLY VENTILATED. DO NOT ALLOW SMOKING, OPEN FLAME, SPARKS OR ANY SPARK PRODUCING TOOLS OR EQUIPMENT NEAR THE BATTERY.**

 **DANGER: BATTERY ELECTROLYTE FLUID IS AN EXTREMELY CAUSTIC SULFURIC ACID SOLUTION THAT CAN CAUSE SEVERE BURNS. DO NOT PERMIT FLUID TO CONTACT EYES, SKIN, CLOTHING, PAINTED SURFACES, ETC. WEAR PROTECTIVE GOGGLES, PROTECTIVE CLOTHING AND GLOVES WHEN HANDLING A BATTERY. IF YOU SPILL THE FLUID, FLUSH THE AFFECTED AREA IMMEDIATELY WITH CLEAR WATER.**

 **DANGER: DO NOT USE ANY JUMPER CABLES OR BOOSTER BATTERY TO CRANK AND START THE GENERATOR ENGINE. IF ANY BATTERY HAS DISCHARGED, REMOVE IT FROM THE VEHICLE FOR RECHARGING.**

## MAJOR SERVICE MANUAL

To obtain a service manual for your generator, order it from your dealer/distributor or contact the factory. Be sure to identify your MODEL NUMBER and SERIES.



## DRIVE BELTS

The engine drives the generator rotor by means of a pulley and drive belt arrangement. The drive train, drive belt and pulleys are warranted for the life of the generator. Drive belt tension was properly adjusted before the unit was shipped from the factory. If you suspect that drive belt tension is incorrect, contact an authorized service facility.

## EXERCISING THE GENERATOR

Generac recommends that you start and operate the generator at least once every seven days. Let the unit run for at least 30 minutes to "exercise" the engine.

## OUT OF SERVICE PROTECTION

If you cannot exercise the generator every seven days and it is to be out of service longer than 30 days, prepare the generator for storage as follows:

- Start the engine and let it warm up.
- Close the fuel shutoff valve in the fuel supply line and let the engine "run out of gas."
- While the engine is still warm from running, drain the oil completely. Refill crankcase with SAE 10W-30 oil having API classification "For Service SF."
- Attach a tag to the engine indicating the viscosity and classification of the oil in the crankcase.

- Remove spark plugs and pour about two or three tablespoons of clean, fresh engine oil into spark plug threaded openings. Crank engine several times to distribute oil, then install and tighten spark plugs.
- Remove the battery and store in a cool, dry room on a wooden board. Never store the battery on any concrete or wooden floor.
- Clean and wipe the entire generator.

## RETURN THE UNIT TO SERVICE AFTER STORAGE

To return the unit to service after storage, proceed as follows:

- Check tag on engine for oil viscosity and classification. Verify that the correct recommended oil is used in engine. If necessary, drain and refill with proper oil.
- Check battery. Fill all cells to the proper level with distilled water. DO NOT USE TAP WATER IN THE BATTERY. Recharge battery to 100% state of charge, or, if defective, replace the battery.
- Turn OFF all electrical loads, add gasoline if necessary, then start the engine.
- Let engine warm up.
- Apply electrical loads to at least 50% of the unit's rated wattage capacity.
- When engine is thoroughly warmed up, shut it down.

THE GENERATOR IS NOW READY FOR SERVICE.

# TROUBLESHOOTING

PROBLEM	POSSIBLE CAUSE(S)	REMEDY
Engine won't crank	<ol style="list-style-type: none"> <li>1. 15 amp fuse blown.</li> <li>2. Loose, corroded or defective battery cable(s).</li> <li>3. Battery is discharged or defective.</li> <li>4. Defective starter contactor.</li> <li>5. Defective starter motor.</li> <li>6. Defective control relay (CR1).</li> </ol>	<ol style="list-style-type: none"> <li>1. Replace blown fuse.</li> <li>2. Tighten, clean or replace, as necessary.</li> <li>3. Recharge or replace battery.</li> <li>4. Replace starter contactor.</li> <li>5. Replace starter motor.</li> <li>6. Replace control relay.</li> </ol>
Engine cranks, won't start	<ol style="list-style-type: none"> <li>1. Out of fuel.</li> <li>2. Fuel shutoff valve is closed.</li> <li>3. Fuel pump not operating.</li> <li>4. Automatic choke not operating properly.</li> <li>5. Engine is flooded.</li> <li>6. Fuel filter is clogged.</li> <li>7. Defective Controller Circuit Board</li> <li>8. Engine spark plugs defective.</li> <li>9. Bad ignition magneto on engine.</li> <li>10. Bad carburetor.</li> <li>11. Dirty air cleaner.</li> </ol>	<ol style="list-style-type: none"> <li>1. Refill fuel tank.</li> <li>2. Open fuel shutoff valve(s).</li> <li>3. Repair or replace pump.</li> <li>4. Repair, replace or adjust.</li> <li>5. Wait 5-10 minutes; try again.</li> <li>6. Replace filter if clogged.</li> <li>7. Replace bad circuit board.</li> <li>8. Clean, regap or replace as needed.</li> <li>9. Replace if defective.</li> <li>10. Adjust, repair or replace.</li> <li>11. Clean or replace as needed.</li> </ol>
Engine starts hard, run rough.	<ol style="list-style-type: none"> <li>1. Dirty engine air cleaner.</li> <li>2. Automatic choke is sticking.</li> <li>3. Defective spark plugs.</li> <li>4. Defective ignition magneto,</li> </ol>	<ol style="list-style-type: none"> <li>1. Clean or replace as needed.</li> <li>2. Free choke linkage as needed.</li> <li>3. Clean, regap or replace.</li> <li>4. Replace it if defective.</li> </ol>
Engine starts, then shuts down.	<ol style="list-style-type: none"> <li>1. Engine oil level is low</li> <li>2. Bad control relay (CR1).</li> <li>3. Bad low oil pressure switch.</li> <li>4. Bad control relay (CR2).</li> </ol>	<ol style="list-style-type: none"> <li>1. Add oil as needed.</li> <li>2. Replace if bad (CR1).</li> <li>3. Replace, if bad.</li> <li>4. Replace bad relay (CR2).</li> </ol>
No AC output voltage	<ol style="list-style-type: none"> <li>1. Main breakers open.</li> <li>2. Transfer switch (if so equipped) is set to wrong position.</li> <li>3. Failure in vehicle electrical system.</li> <li>4. Generator component failure.</li> </ol>	<ol style="list-style-type: none"> <li>1. Close main breakers.</li> <li>2. Reset transfer switch.</li> <li>3. See vehicle manual.</li> <li>4. Contact an authorized service facility.</li> </ol>

# ELECTRICAL DATA

Drawing No. 92116

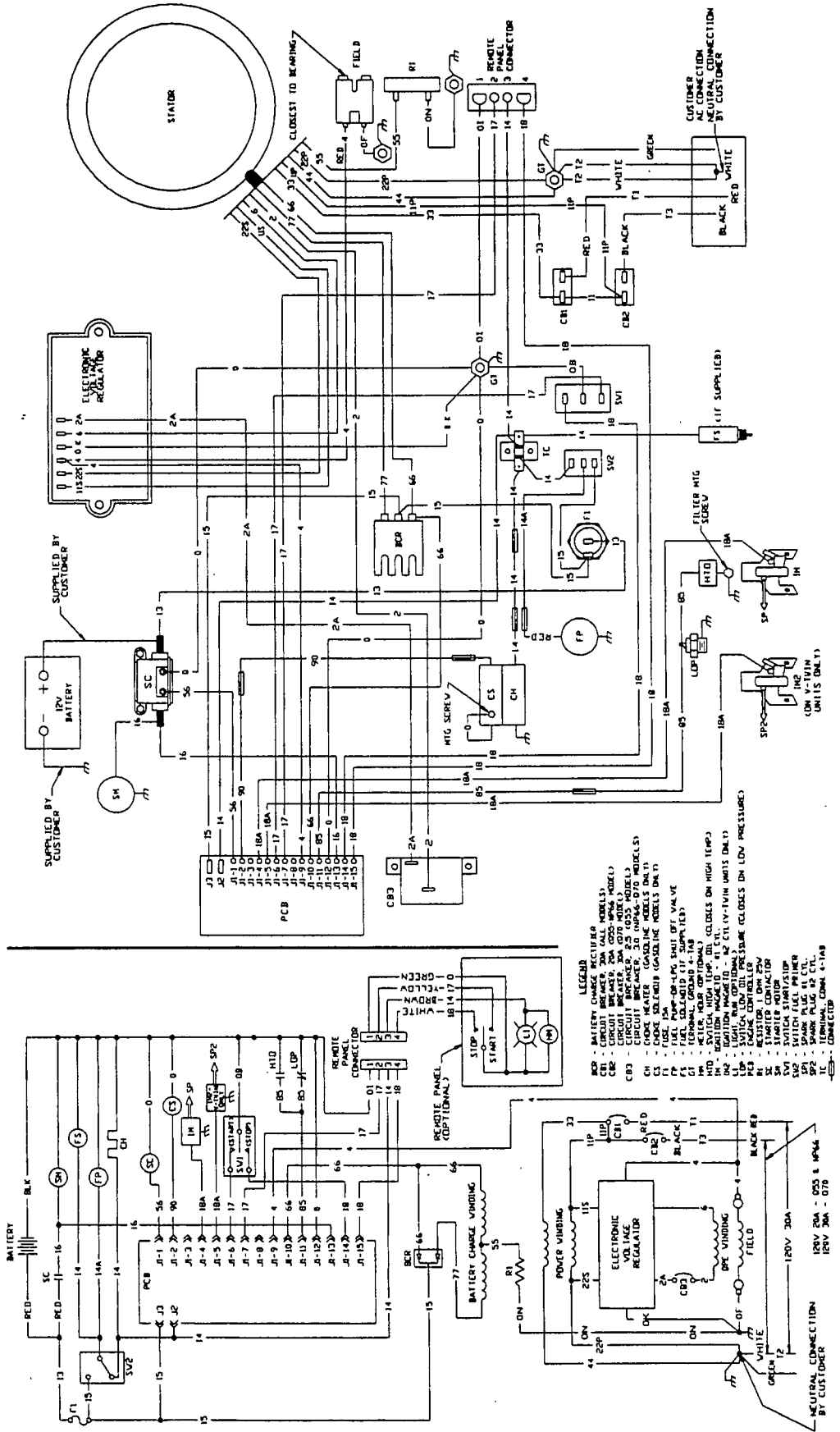

# EXPLODED VIEW — BASE AND PULLEYS

Drawing No. 91356

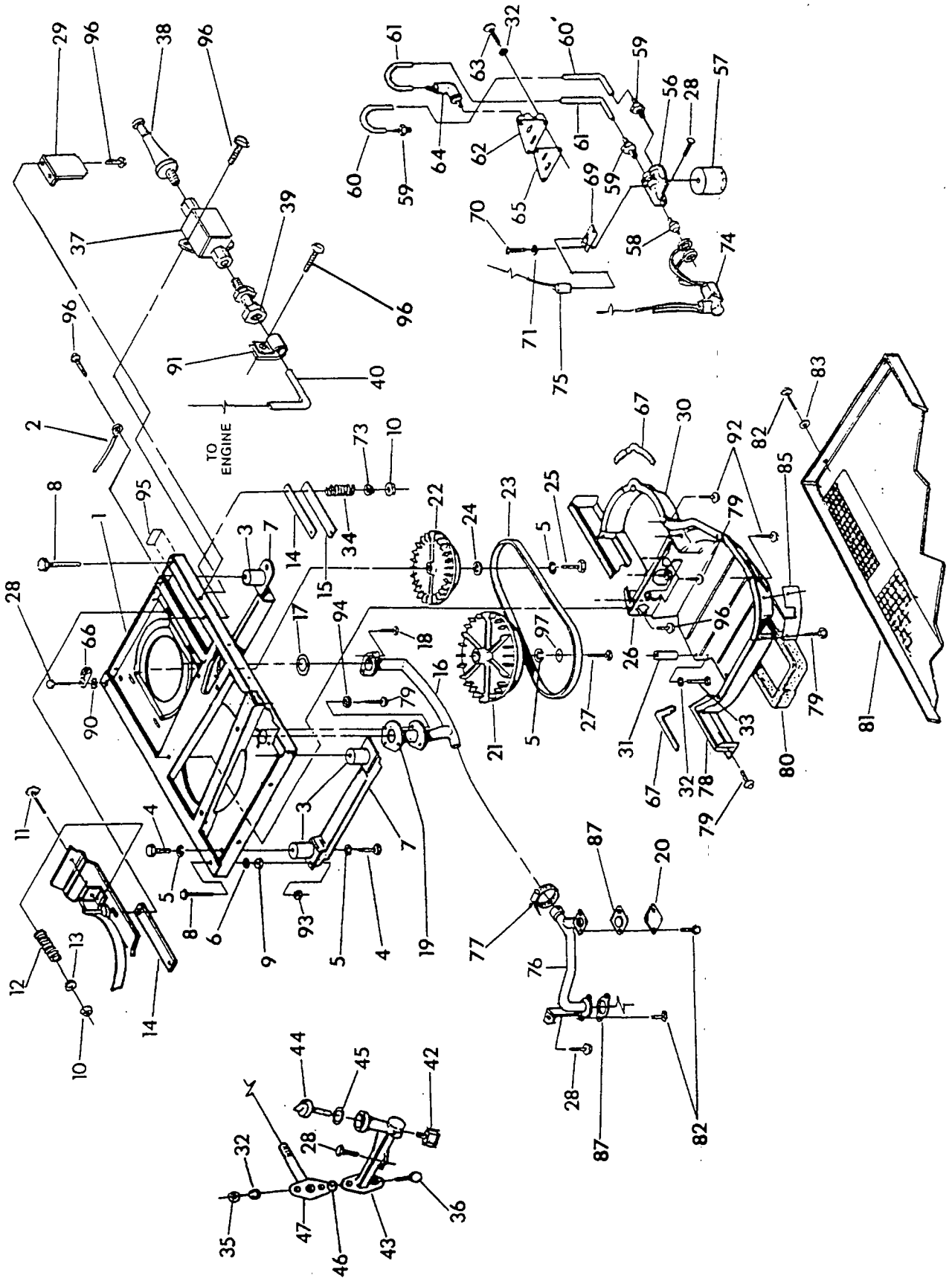

# REPAIR PARTS — BASE AND PULLEYS

Drawing No. 91356

ITEM	PART NO.	QTY.	DESCRIPTION	ITEM	PART NO.	QTY.	DESCRIPTION
1	86318	1	Mounting Base	43	75710-A	1	Oil Fill and Drain Tube
2	90141	1	Ground Cable	44	74958	1	Cap and Dipstick Assembly
3	46911	4	Rubber Mount	45	67871	1	O-ring Cap
4	25017	8	3/8"-16 x 1/2" Capscrew	46	75712	1	O-ring Drain
5	46526	10	M10 Lock Washer	47	75711	1	O-ring Adaptor
6	22129	2	M8 Lock Washer	56	73179	1	Oil Filter Support
7	72391	2	Rubber Mount Skid	57	70185	1	Oil Filter (FRAM PH #3614)
8	77603	2	5/16"-18 x 3-1/2" Bolt	58	77667	1	Oil Pressure Switch
9	22259	2	5/16-18 Hex Nut	59	74948	3	5/16" Fitting
10	52858	6	M8-1.25 Flanged Lock Nut	60	74950	1	Outer Oil Tube
11	51730	2	M8-1.25 x 60mm Capscrew	61	74951	1	Inner Oil Tube
12	29459	2	Belt Tension Spring	62	73134	1	Oil Pad Adaptor
13	75215	2	Spring Center Washer	63	38750	3	M6-1.00 x 30mm Capscrew
14	73146	4	Nylon Slide	64	74949	1	5/16" 90-degree Fitting
15	75209	2	Nylon Slide Support	65	68548	1	Oil Pad Gasket
16	73174	1	Exhaust Manifold	66	62684	1	Grounding Lug
17	79678	2	Exhaust Manifold Gasket	67	29289	—	1/16" x 8' Foam Tape
18	55173	4	M8-1.25 x 20mm Capscrew	69	75281	1	High Temperature Switch
19	72383	2	Collector Pan Gasket	70	74027	2	M3-0.5 Pan Head Screw
20	90859	1	Cover Plate - External	71	43182	2	M3 Lock Washer
21	75224-F	1	Engine Pulley	73	75237	4	Spring Retainer Washer
22	73106-F	1	Alternator Pulley	74	77681	1	LOS 2-wire Vinyl Cap
23	75216	1	40" Poly Vinyl 4L Belt	75	75474	1	17" x 42" x 2" Vinyl Cap
24	49451	1	Pulley Retainer Washer	76	90800	1	Exhaust Elbow
25	42633	1	3/8"-24 x 1" Capscrew	77	74907	1	1-1/8" Exhaust Clamp
26	77017	1	Blower Housing Guide	78	75226	1	Air Cover
27	73118	1	3/8"-24 x 2-1/2" Capscrew	79	56893	14	#10-24 x 1/2" Screw
28	74906	5	M6-1.00 x 20mm Screw	80	75229	1	Slide Pan Gasket
29	91123	1	Fuel Pump Bracket	81	75227	1	Slide Pan
30	72375	1	Blower Housing	82	79246	8	M6-1.0 x 16mm Capscrew with lock washer
31	73185	1	Blower Housing Spacer	83	22473	4	M6 Flat Washer
32	22097	6	M6 Lock Washer	85	72384-C	1	Exhaust Outlet Cover
33	77682	1	M5-0.8 x 80mm Capscrew	87	77643	2	Exhaust Outlet Gasket
34	75242	4	Generator Mounting Spring	90	22447	1	M8 Toothed Lock Washer
35	49813	2	M6-1.00 Hex Nut	91	90088	1	Vinyl Coated Clamp
36	45757	2	M6-1.0 x 25mm Capscrew	92	74908	10	M5-0.8 x 10mm Screw
37	90475	1	Fuel Pump	93	81105	2	5/16"-18 Flange Nut (special)
38	87769	1	Fuel Filter	94	23897	6	M5 Flat Washer
39	87768	1	1/8" Pipe to 1/4" Tube Fitting	95	67210	1	Decal — Ground
40	87770	1	Fuel Line	96	45756	9	M6 x 10mm Taptite Screw
42	26925	1	3/8" NPT Oil Drain	97	22131	1	M10 Flat Washer

# EXPLODED VIEW — ALTERNATOR & PANEL

Drawing No. 92118

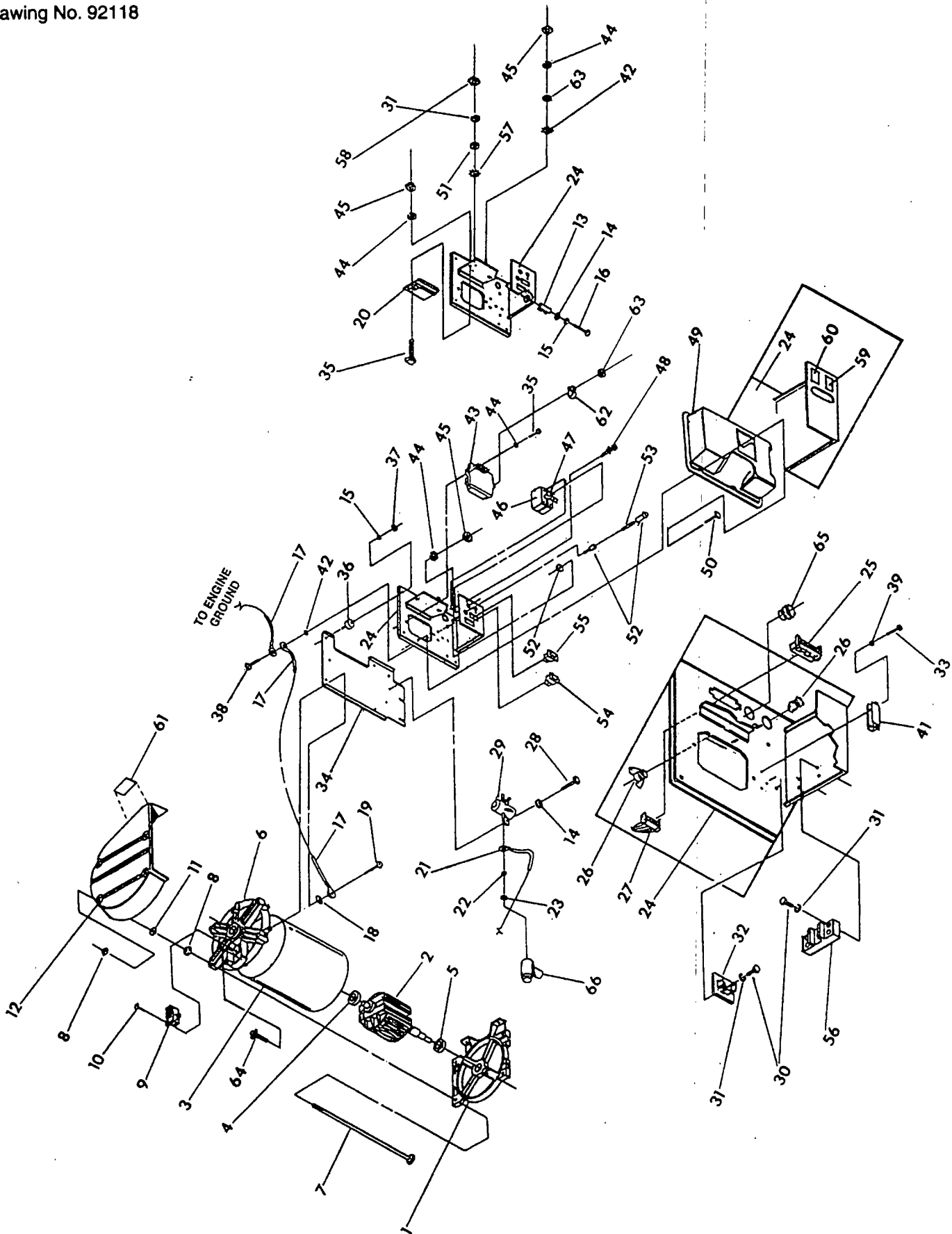

# REPAIR PARTS — ALTERNATOR & PANEL

Drawing No. 92118

ITEM	PART NO.	QTY.	DESCRIPTION	ITEM	PART NO.	QTY.	DESCRIPTION
1	75995	1	Lower Bearing Carrier	34	86317	1	Panel Support Bracket
2	77004-G	1	Rotor Assembly	35	75235	4	M5-0.8 x 30mm Capscrew
3	87845-G	1	Stator Assembly	36	82737	4	Vibration Mount
4	73159	1	Ball Bearing	37	49813	4	M6 Hex Nut
5	31971	1	Ball Bearing	38	49815	1	M5-0.8 x 16mm Capscrew
6	72379	1	Upper Bearing Carrier	39	43182	2	M3 Lock Washer
7	77006	4	Stator Stud	41	54502	1	3A Circuit Breaker
8	52858	8	M8-1.25 Flange Lock Nut	42	67444	1	M5 Shakeproof Washer
9	66386	1	Brush Holder	43	83049	1	Voltage Regulator
10	66849	2	M5-0.80 x 15mm	44	49226	6	M5 Lock Washer
11	27756	4	Nylon Washer	45	51716	4	M5-0.80 Hex Nut
12	86314	1	Generator Top Housing	46	90145	1	30A Circuit Breaker
13	75234	1	Resistor	47	90145	1	30A Circuit Breaker
14	22473	3	Flat Washer	48	25105	4	No. 6-32 Screw with lock washer
15	22097	5	M6 Lock washer	49	86315	1	Panel Cover
16	74095	1	M6-1.00 x 60mm Capscrew	50	90734	4	M4-0.7 x 16mm Capscrew and Flat Washer
17	90141	2	Ground Cable	51	22985	1	M4 Flat Washer
18	22447	1	Shakeproof Lock Washer	52	32300	1	Fuse Holder
19	74906	4	M6-1.00 x 20mm Screw	53	22676	1	15 Amp Fuse
20	92234	1	Controller Circuit Board	54	87798	1	Start/Stop Switch
21	10-74260	1	Starter Cable	55	92113	1	Fuel Pump Switch
22	22129	2	5/16" Lock Washer	56	75210-A	1	Terminal Block
23	22259	2	5/16"-18 Hex Nut	57	23365	1	M4 Shakeproof Washer
24	86316	1	Panel Sheet Metal	58	51715	1	M4-0.7 Hex Nut
25	53650	1	4-pin Connector	59			NOT USED ON THIS UNIT
26	91915	1	Connector	60	90157	1	Decal — C.B. Rating 30 Amp
27	75244	1	Remote Harness	60			NOT USED ON THIS UNIT
28	66476	2	M6-1.0 x 12mm Capscrew with lock washer	61	89438-B	1	Customer Connection Decal
29	56739	1	Starter Contactor	62	31791	1	Hose Clamp
30	75476	3	M4-0.7 x 16mm Capscrew	63	23897	1	M5 Flat Washer
31	22264	4	M4 Lock Washer	64	74908	1	M5 x 10mm Taptite Screw
32	97939	1	Battery Charge Rectifier	65	23484-S	1	Bushing
33	90987	2	M3-0.5 x 15mm Capscrew	66	75763	1	Battery Cable Boot

# EXPLODED VIEW — CARBURETOR AND AIR CLEANER

Drawing No. 93753

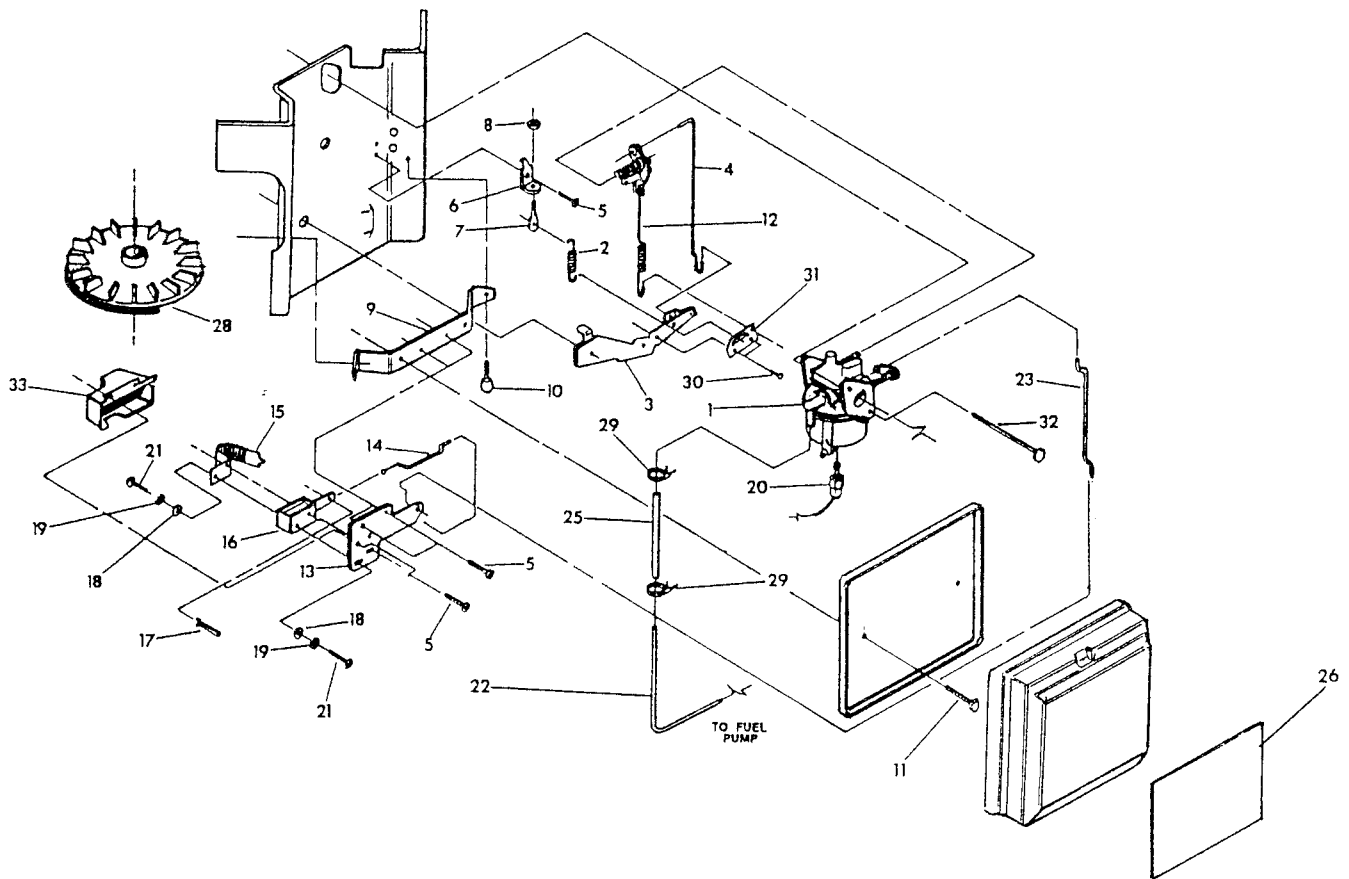

ITEM	PART NO.	QTY.	DESCRIPTION	ITEM	PART NO.	QTY.	DESCRIPTION
1	73112B	1	Carburetor Assembly	18	31879	4	No. 4 Flat Washer
2	74962-C	1	Governor Spring	19	22159	4	No. 4 Lock Washer
3	70155	1	Governor Lever	20			NOT USED WITH THIS UNIT
4	70108	1	Governor-to-Carburetor Rod	21	72536	2	No. 4-40 x 1/4" Screw
5	56893	5	No. 10-24 x 1/2" Screw	22	87770	1	5/16" dia. Fuel Line
6	74961	1	Governor Adjuster Bracket	23	74946	1	Choke Link
7	47227	1	Governor Adjuster Screw	25	47662-T	1	4-1/2" long Fuel Hose
8	37398	1	Hex Lock Nut (nylon)	26	91351	1	Air Cleaner Decal
9	73131	1	Air Cleaner Support Bracket	27	75252	1	Carburetor Overhaul Kit
10	66476	2	M6-1.0 x 12mm Hex Screw	28	73130	1	Flywheel Assembly
11	70575	2	M6-1.0 x 25mm Hex Screw	29	40173	2	Hose Clamp (screw type)
12	70125	1	Anti-Lash Spring	30	66829	2	1/8" dia. x 1/8" long Rivet
13	73374	1	Choke Support Bracket	31	75944	1	Governor Spring Bracket
14	74947	1	Choke Control Rod	32	70594	2	M6-1.0 x 93mm Capscrew with washer
15	89473	1	Bimetal Choke Assembly	33	77075	1	Choke Coil Cover
16	91306	1	Choke Solenoid				
17	77091	1	Cotter Pin				



# EXPLODED VIEW — ENGINE SHEET METAL

Drawing No. 89403

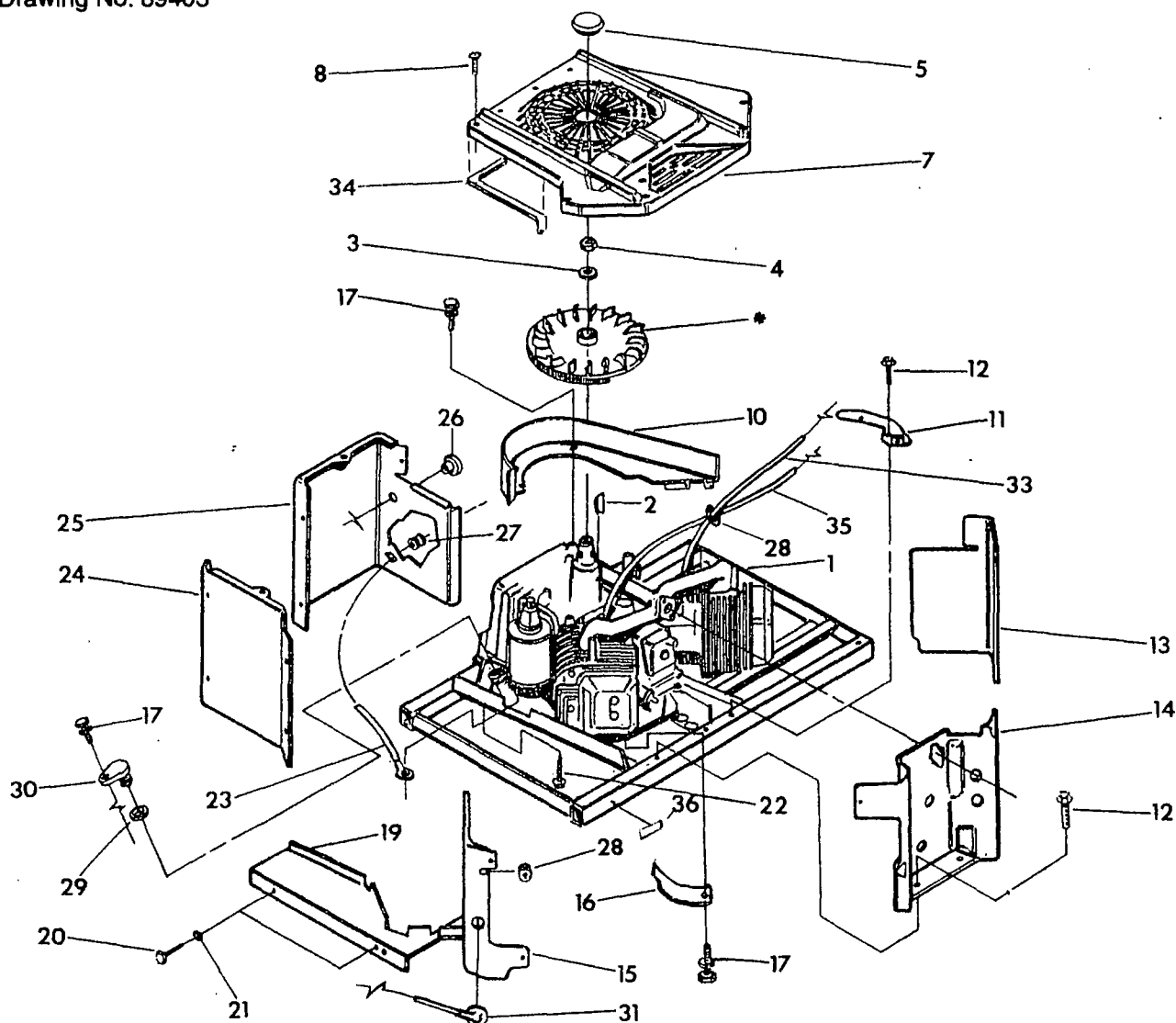

ITEM	PART NO.	QTY.	DESCRIPTION	ITEM	PART NO.	QTY.	DESCRIPTION
1	---	---	1	21	22129	2	M8 Lockwasher
2	67877	1	6 x 25 Woodruff Key	22	75246	4	3/8"-16 x 1-1/4" Screw
3	67198-N	1	Belleville Washer	23	10-74260	1	No. 16 Wire Assembly
4	67890	1	M20-1.50 Hex Nut	24	74900	1	Starter Cover
5	87865	1	Flywheel Access Plug	25	73186	1	Crankcase Wrapper
7	86313	1	Engine Housing Top	26	81108	1	Snap Bushing
8	56893	23	No. 10-24 x 3/8" Screw	27	22717-B	1	Rubber Grommet
10	87750	1	Flywheel Scroll	28	22717-A	2	Rubber Grommet
11	74916	1	No. 2 Base Cover	29	67866	1	O-ring
12	74908	9	M5 x 10mm Taptite Screw	30	77001	1	Oil Fill Plug
13	73190	1	No. 2 Cylinder Wrapper	31	73132	2	Spark Plug Boot
14	78858	1	Valley Cover	33	87858A	1	Ground Wire Assembly #2 cylinder
15	78859	1	No. 1 Cylinder Wrapper	34	29289	2 ft.	Foam Tape
16	74902	2	Wrapper — Barrel	35	87858B	1	Ground Wire Assembly #1 cylinder
17	66476	2	M6-1.00 x 12mm Capscrew with lock washer	36	50277	1	Oil Drain Decal
19	73191	1	No. 1 Base Cylinder Cover				
20	42907	2	M8-1.25 x 16mm Capscrew				

# EXPLODED VIEW — GN ENGINE PARTS

Drawing No. 79216

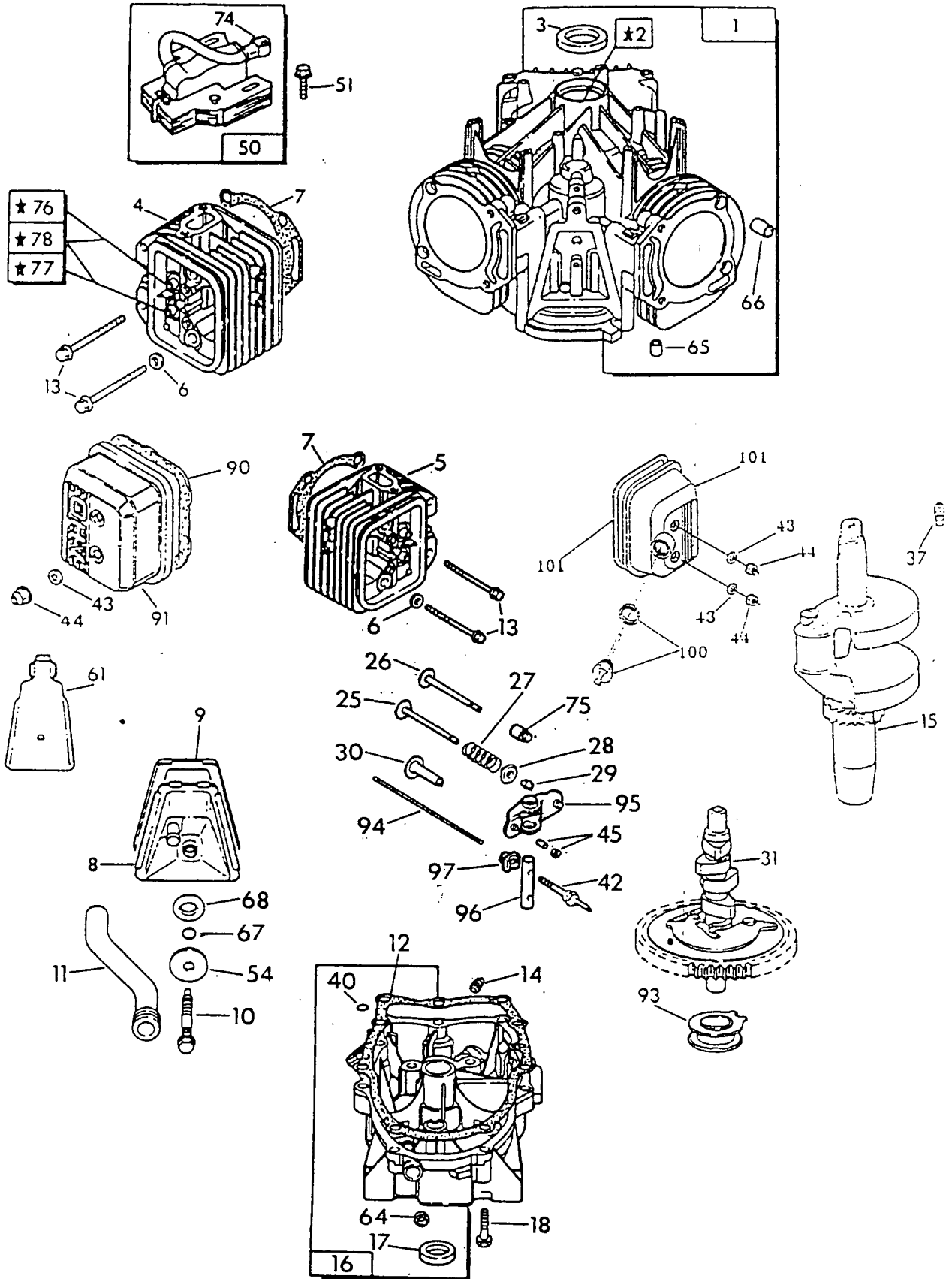

# EXPLODED VIEW — GN ENGINE PARTS

Drawing No. 79216

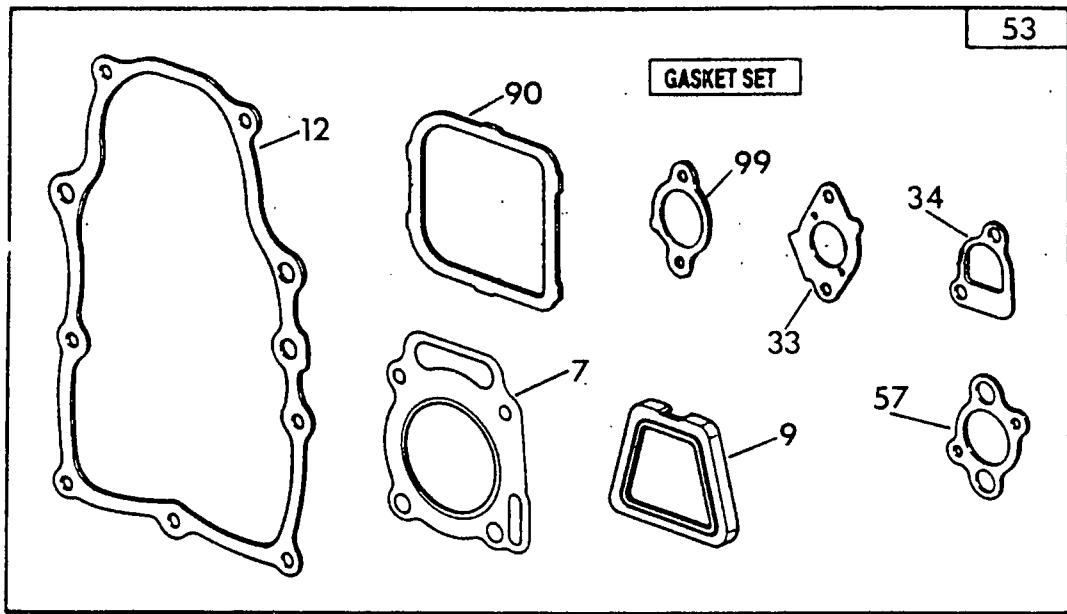
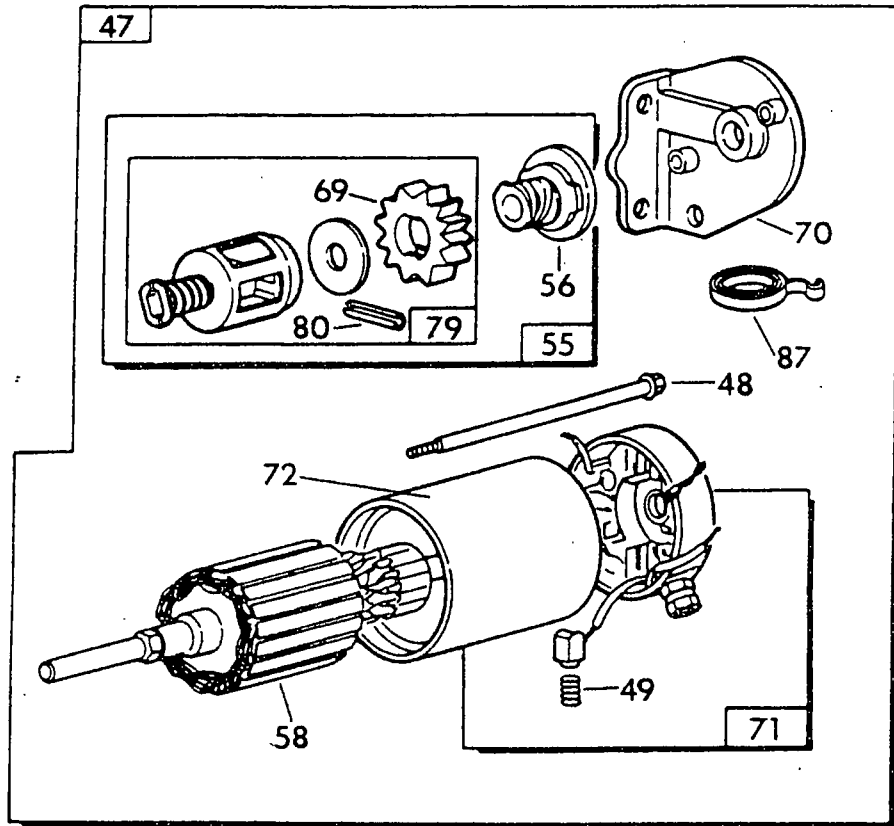

# EXPLODED VIEW — GN ENGINE PARTS

Drawing No. 79216

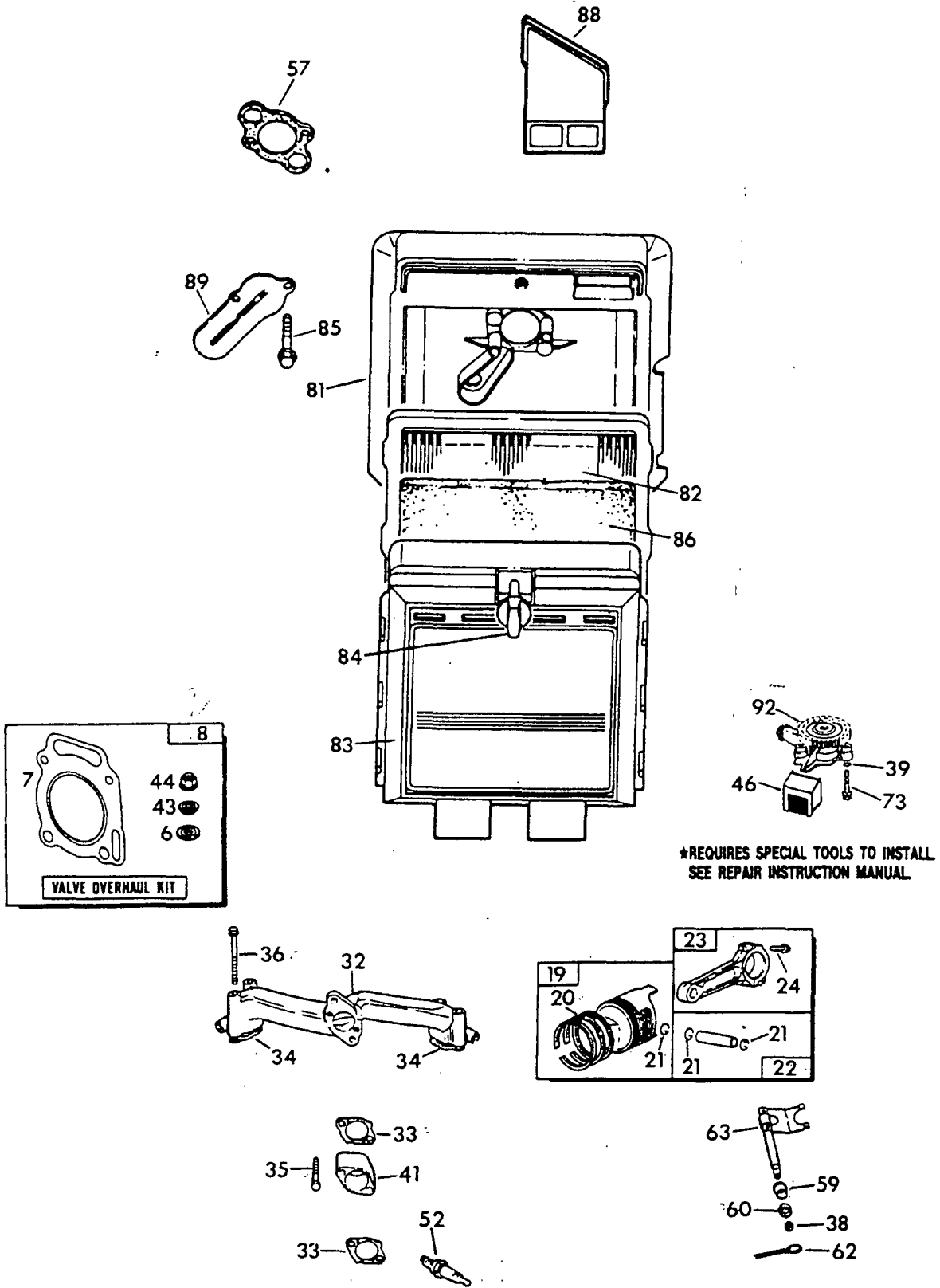

# REPAIR PARTS LIST — GN-480 ENGINE

Drawing No. 79216

ITEM	PART NO.	QTY.	DESCRIPTION	ITEM	PART NO.	QTY.	DESCRIPTION
1	69331	1	Cylinder Assembly	51	72536	2	Ignition Armature Screw
2	69333	1	Sleeve Bearing	52	72347	2	R12YC Champion Spark Plug
3	67805	1	Oil Seal	53	75258	1	Engine Gasket Kit
4	79234	1	No. 1 Cylinder Head Assem.	54	75259	1	Breather Screw Washer
5	79235	1	No. 2 Cylinder Head Assem.	55	75260	1	Starter Drive Assembly
6	70169	4	Sealing Washer	56	75261	1	Clutch Assembly
7	69332	2	Cylinder Head Gasket	57	66480	1	Air Cleaner Gasket
8	72301	1	Breather Assembly	58	75269	1	Armature Assembly
9	72315	1	Breather Gasket	59	72361	1	Governor Shaft Bushing
10	70190	2	Breather Screw	60	72362	1	Governor Shaft Bushing
11	70596	1	Breather Tube	61	70199	1	Breather Baffle
12	69336	1	Oil Sump Gasket	62	72366	1	Cotter Pin
13	69325	8	Cylinder Head Bolt	63	72367	1	Governor Fork
14	67888	2	3/8" NPT Oil Drain Plug	64	72365	1	Governor Shaft Washer
15	72334	1	Crank Shaft Assembly	65	68555	2	Crankcase Dowel
16	75247	1	Oil Sump Assembly	66	67806	4	Cylinder Head Dowel
17	67924	1	Oil Seal Assembly	67	75262	1	Breather Seal Screw
18	67878	9	Oil Sump Bolt	68	75263	1	Breather Seal Screw
19	75248	2	Standard Piston Assembly	69	75264	1	Starter Gear
20	75249	2	Standard Piston Ring Set	70	75265	1	Starter End Cap Assembly
21	69327	4	Piston Locking Ring	71	75266	1	Commutator Cap Assembly
22	75250	2	Standard Piston Ring	72	75267	1	Starter Housing Assembly
23	75251	2	Connecting Rod Assembly	73	68572	2	Oil Pump Screw
24	72346	4	Connecting Rod Bolt	74	75272	2	Spark Plug Terminal
25	69316	2	Exhaust Valve	75	70122	2	Valve Stem Seal
26	69317	2	Intake Valve	76	67910	2	Intake Valve Seat
27	67816	4	Valve Spring	77	67911	2	Exhaust Valve Seat
28	69320	4	Valve Spring Retainer	78	67813	4	Valve Guide
29	70513	4	Valve Keeper	79	75268	1	Retainer and Pin
30	70584	4	Valve Tappet	80	75270	1	Roll Pin
31	70530	1	Camshaft Assembly	81	70592	1	Air Cleaner Base
32	72358	1	Intake Manifold	82	73123	1	Air Filter
33	69379	2	Carburetor Mounting Gasket	83	70593	1	Air Cleaner Cover
34	67895	2	Intake Manifold Gasket	84	72300	1	Air Cleaner Cover Screw
35	70594	2	Carburetor Mounting Bolt	85	67156	2	Air Cleaner Base Screw
36	67158	4	Intake Manifold Mounting Bolt	86	69341	1	Foam Pre-cleaner
37	68574	1	1/8" NPT Plug Pipe	87	80011	1	Brush Set Spring
38	68554	1	Governor Shaft Seal	88	70597	1	Air Inlet Tube
39	68573	1	Oil Pump O-ring	89	69358	1	Breather Deflector
40	70506	1	Oil Galley O-ring	90	67920	2	Valve Cover Gasket
41	70554	1	Carburetor Spacer	91	69328	2	Valve Cover
42	70568	4	Rocker Arm Stud	92	70547	1	Oil Pump Assembly
43	75253	4	Washer Valve Cover Seal	93	70536	1	Governor Slider
44	67885	4	M6 Nylon Nut	94	70577	4	Push Rod
45	75254	4	Valve Adjust Screw	95	70599	4	Rocker Arm Assembly
46	70535	1	Oil Screen	96	70567	2	Rocker Arm Shaft
47	75255	1	Starter Motor	97	70566	4	Rocker Arm Support
48	75256	2	Starter Motor Bolt	98	75271	1	Valve Overhaul Kit
49	75257	4	Brush Assembly	99	67897	2	Exhaust Gasket
50	67891	1	Ignition Armature Assembly	100	91481	1	Gasket and Cap Assembly
				101	91480	1	Rocker Arm Cover

## **CALIFORNIA EMISSION CONTROL WARRANTY STATEMENT**

### **YOUR WARRANTY RIGHTS AND OBLIGATIONS**

The California Air Resources Board ("CARB") and Generac Corporation are pleased to explain the Emission Control System Warranty on your new recreational vehicle generator engine. In California, new utility and lawn and garden equipment engines must be designed, built and equipped to meet the State's stringent anti-smog standards. Generac Corporation will warrant the emission control system on your recreational vehicle for the periods of time listed below provided there has been no abuse, neglect, unapproved modification, or improper maintenance of your recreational vehicle generator engine.

Your emission control system may include parts such as the carburetor, ignition system and exhaust system. Also included may be the compression release system and other emission-related assemblies.

Where a warrantable condition exists, Generac Corporation will repair your recreational vehicle generator engine at no cost to you for diagnosis, parts and labor.

### **MANUFACTURER'S EMISSION CONTROL SYSTEM WARRANTY COVERAGE:**

Emissions control systems on 1995 and later model year recreational vehicle generator engines are warranted for two years as hereinafter noted. If, during such warranty period, any emission-related part on your engine is defective in materials or workmanship, the part will be repaired or replaced by Generac Corporation.

### **OWNER'S WARRANTY RESPONSIBILITIES:**

As the recreational vehicle generator engine owner, you are responsible for the performance of the required maintenance listed in your owners manual. Generac Corporation recommends that you retain all receipts covering maintenance on your recreational vehicle generator engine, but Generac Corporation will not deny warranty solely due to the lack of receipts or for your failure to provide written evidence of the performance of all scheduled maintenance.

As the recreational vehicle generator engine owner, you should, however, be aware that Generac Corporation may deny you warranty coverage if your recreational vehicle generator engine or a part thereof has failed due to abuse, neglect, improper maintenance or unapproved modifications.

You are responsible for presenting your recreational vehicle engine to a Generac Corporation Authorized Service Outlet as soon as a problem exists. The warranty repairs should be completed in a reasonable amount of time, not to exceed 30 days.

Warranty service can be arranged by contacting either a Generac Corporation Authorized Service Outlet or by contacting Generac Corporation at:

**GENERAC CORPORATION PH: (414) 544-4811**  
**P.O. BOX 8 FX: (414) 544-0179**  
**WAUKESHA, WI 53187**

**IMPORTANT NOTE:** This warranty statement explains your rights and obligations under the Emission Control System Warranty ("ECS Warranty") which is provided to you by Generac Corporation pursuant to California law. See also the Generac Corporation Limited Warranties for Generac Corporation which is enclosed herewith on a separate sheet and also is provided to you by Generac Corporation. The ECS Warranty applies only to the emission control system of your new engine. To the extent that there is any conflict in terms between the ECS Warranty and the Generac Corporation Warranty, the ECS Warranty shall apply except in any circumstances in which the Generac Corporation Warranty may provide a longer warranty period. Both the ECS Warranty and the Generac Corporation Warranty describe important rights and obligations with respect to your new engine.

Warranty service can only be performed by a Generac Corporation Authorized Service Outlet. At the time of requesting warranty service, evidence must be presented of the date of the sale to the original purchaser. The purchaser shall pay any charges for making service calls and/or for transporting the products to and from the place where the inspection and/or warranty work is performed. The purchaser shall be responsible for any damage or loss incurred in connection with the transportation of any engine or any part(s) thereof submitted for inspection and/or warranty work.

**IF YOU HAVE ANY QUESTIONS REGARDING YOUR WARRANTY RIGHTS AND RESPONSIBILITIES, YOU SHOULD CONTACT GENERAC CORPORATION AT 1-800-222-3136**

## EMISSION CONTROL SYSTEM WARRANTY

Emission Control System Warranty ("ECS Warranty") for 1995 and Later Model Year recreational vehicle generator Engines:

**Applicability:** This warranty shall apply to 1995 and later model year recreational vehicle generator engines. The ECS Warranty Period ("ECS Warranty Period") shall begin on the date the new engine or equipment is delivered to its original, end-use purchaser and shall continue for 24 consecutive months thereafter.

**B. General Emissions Warranty Coverage:** Generac Corporation warrants to the original, end-use purchaser of the new engine or equipment and to each subsequent purchaser that each of its recreational vehicle generator engines is:

1. Designed, built and equipped so as to conform with all applicable regulations adopted by the Air Resources Board pursuant to its authority, and
2. Free from defects in materials and workmanship which, at any time during the ECS Warranty Period, will cause a warranted emissions - related part to fail to be identical in all material respects to the part as described in the engine manufacturer's application for certification.

**C. The ECS Warranty only pertains to emissions-related parts on your engine, as follows:**

1. Any warranted, emissions-related parts which are not scheduled for replacement as required maintenance in the Owner's Manual shall be warranted for the ECS Warranty Period. If any such part fails during the ECS Warranty Period, it shall be repaired or replaced by Generac Corporation according to Subsection (4) below. Any such part repaired or replaced under the ECS Warranty shall be warranted for any remainder of the ECS Warranty Period.
2. Any warranted, emissions-related part which is scheduled only for regular inspection as specified in the Owner's Manual shall be warranted for the ECS Warranty Period. A statement in such written instructions to the effect of "repair or replace as necessary" shall not reduce the ECS Warranty Period. Any such part repaired or replaced under the ECS Warranty shall be warranted for any remainder of the ECS Warranty Period.
3. Any warranted, emissions-related part which is scheduled for replacement as required maintenance in the Owner's Manual shall be warranted for the period of time prior to first scheduled replacement point for that part. If the part fails prior to the first scheduled replacement, the part shall be repaired or replaced by Generac Corporation according to Subsection (4) below. Any such emissions-related part repaired or replaced under the ECS Warranty shall be warranted for the remainder of the ECS Warranty Period prior to the first scheduled replacement point for such emissions-related part.
4. Repair or Replacement of any warranted, emissions-related part under this ECS Warranty shall be performed at no charge to the owner at a Generac Corporation Authorized Service Outlet.
5. The owner shall not be charged for diagnostic labor which leads to the determination that a part covered by the ECS Warranty is in fact defective, provided that such diagnostic work is performed at a Generac Corporation Authorized Service Outlet.
6. Generac Corporation shall be liable for damages to other original engine components or approved modifications proximately caused by a failure under warranty of any emission-related part covered by the ECS Warranty.
7. Throughout the ECS Warranty Period, Generac shall maintain a supply of warranted emission-related parts sufficient to meet the expected demand for such emission-related parts.
8. Any Generac Corporation authorized and approved emission-related replacement part may be used in the performance of any ECS warranty maintenance or repairs and will be provided without charge to the owner. Such use shall not reduce Generac Corporation ECS warranty obligations.
9. Unapproved add-on modified parts may not be used to modify or repair a Generac Corporation engine. Such use voids this ECS Warranty and shall be sufficient grounds for disallowing an ECS Warranty claim. Generac Corporation shall not be liable hereunder for failures of any warranted parts of a Generac Corporation engine caused by the use of such an unapproved add-on or modified part.

### EMISSION RELATED PARTS INCLUDE THE FOLLOWING:

1. Fuel Metering System.
  - a. Gasoline carburetor assembly (if so equipped)
    - 1) Fuel filter (if so equipped)
    - 2) Carburetor gaskets
    - 3) Fuel pump
  - a. LP/Natural gas carburetion assembly
    - 1) Fuel controller
    - 2) Mixer and its gaskets (if so equipped)
    - 3) Carburetor and its gaskets (if so equipped)
    - 4) Primary gas regulator (if so equipped)
    - 5) LP liquid vaporizer (if so equipped)
2. Air cleaner assembly
  - a. Air filter element
  - b. Intake pipe
3. Ignition system including:
  - a. Spark plug
  - b. Ignition module
4. Catalytic muffler (if so equipped)
  - a. Muffler gasket (if so equipped)
  - b. Exhaust manifold (if so equipped)
5. Crankcase breather assembly and its components.
  - a. Breather connection tube

## **GENERAC'S THREE-YEAR LIMITED WARRANTY FOR RECREATIONAL VEHICLE NP GENERATORS**

Generac warrants to the original purchaser that its generators will be free from defects in materials or workmanship for the period set forth below from date of original purchase. During said warranty period, Generac will, at its option, repair or replace any part which, upon examination by Generac or Generac Authorized Distributors and/or Dealers, is found to be defective under normal use and service.

### **THREE-YEAR WARRANTY SCHEDULE**

1. All NP Series generators used in a recreational vehicle shall be warranted for a period of three (3) years or 2,000 hours of operation, whichever occurs first. All parts, labor, removal and reinstallation shall be covered for the first two years. Parts and labor on selected generator and engine parts shall be covered during the third year or 2,000 hours, whichever occurs first. These selected parts are limited to: the main Rotor and Stator with regard to the generator; the Cylinder Block, Cylinder Head, Crankshaft, Piston, Valve, Valve Lifter, and Manifolds with regard to the engine.
2. The drive train belt and pulleys (if so equipped) on NP air-cooled generators used in recreational vehicles shall be warranted against failure due to defective materials or normal usage for the life of the generator. For the original owner, this drive train warranty shall include parts and labor plus \$50.00 payment upon return of the failed belt or pulley by the original owner. For succeeding owners, this power train warranty shall cover belt or pulley parts only.
3. Rental units, demonstrators, prime power, or commercial applications, such as construction or utility, are warranted for (1) one year or 2,000 hours, whichever comes first.

All warranty expense allowances are subject to the conditions defined in the published "GENERAC POLICIES AND PROCEDURES" manual.

#### **THIS WARRANTY DOES NOT COVER:**

- Costs of maintenance, installation and startup.
- Failures due to (a) normal wear and tear from GN engine, or (b) accident, misuse, abuse, negligence or improper installation.
- Products which are modified or altered in a manner not authorized by Generac in writing.
- Any incidental, consequential or indirect damages caused by defects in materials or workmanship, or any delay in repair or replacement of defective parts.
- Failure due to misapplication.
- Telephone, telegraph, teletype or other communication expenses.
- Living or travel expenses of persons performing service.
- Any and all transportation/travel expenses.
- Rental equipment used while warranty repairs are being performed.
- Overtime labor.
- Starting batteries, fuses, light bulbs, and engine fluids.

THIS WARRANTY IS IN PLACE OF ALL OTHER WARRANTIES, EXPRESS OR IMPLIED. SPECIFICALLY, GENERAC MAKES NO OTHER WARRANTIES AS TO MERCHANTABILITY OR FITNESS FOR A PARTICULAR PURPOSE. Some states do not allow limitations on how long an implied warranty lasts, so the above limitation may not apply to you. GENERAC'S ONLY LIABILITY SHALL BE THE REPAIR OR REPLACEMENT OF PARTS AS STATED ABOVE. IN NO EVENT SHALL GENERAC BE LIABLE FOR ANY INCIDENTAL OR CONSEQUENTIAL DAMAGES, EVEN IF SUCH DAMAGES ARE A RESULT OF GENERAC'S NEGLIGENCE. Some states do not allow the exclusion or limitation of incidental or consequential damages, so the above limitation may not apply to you. Buyer agrees to make no claims against generac based on negligence.

This warranty gives you specific legal rights, and you may also have other rights, which vary from state to state.

**GENERAC CORPORATION, P.O. Box 8, Hwy 59 and Hillside Road, Waukesha, WI 53187**