

# Orion® StarMax™ 127mm EQ

#9826 Equatorial Maksutov-Cassegrain Telescope



 **ORION®**  
**TELESCOPES & BINOCULARS**  
*Providing Exceptional Consumer Optical Products Since 1975*

**Customer Support (800) 676-1343**  
**E-mail: [support@telescope.com](mailto:support@telescope.com)**  
**Corporate Offices (831) 763-7000**  
**89 Hangar Way, Watsonville, CA 95076**

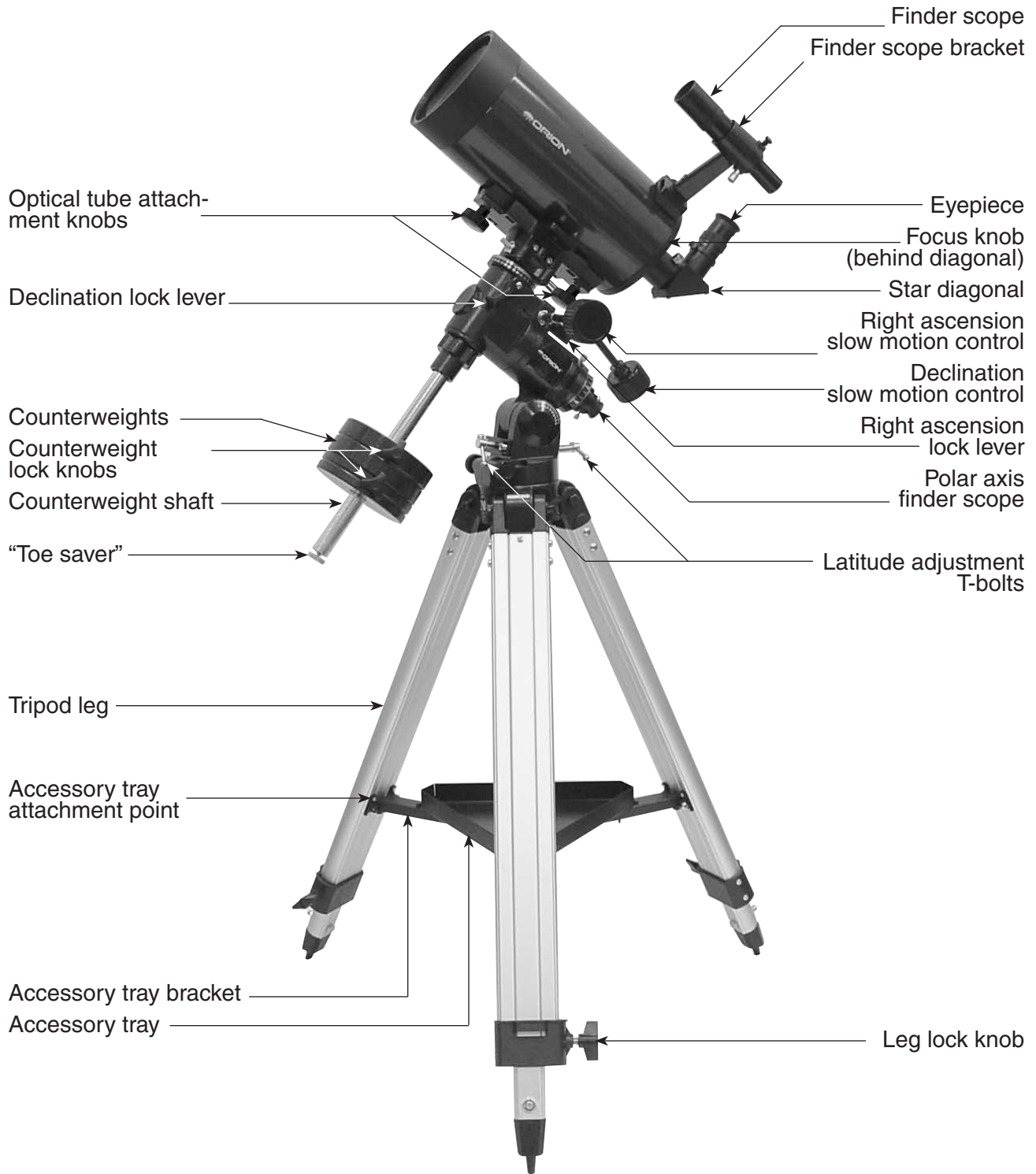

**Figure 1.** StarMax 127mm EQ Parts Diagram

*Welcome to a new world of adventure.* Your new StarMax 127mm EQ is designed for high-resolution observing of astronomical objects, and can also be used for terrestrial exploration. With its precision optics and equatorial mount, you'll be able to locate and enjoy hundreds of fascinating celestial objects, including the planets, Moon, and a variety of deep-sky galaxies, nebulas, and star clusters.

If you have never owned a telescope before, we would like to welcome you to amateur astronomy. Take some time to familiarize yourself with the night sky. Learn to recognize the patterns of stars in the major constellations. With a little practice, a little patience, and a reasonably dark sky away from city lights, you'll find your telescope to be a never-ending source of wonder, exploration, and relaxation.

These instructions will help you set up, properly use and care for your telescope. Please read them over thoroughly before getting started.

## Table of Contents

1. Unpacking . . . . .	3
2. Parts List . . . . .	3
3. Assembly . . . . .	3
4. Getting Started . . . . .	5
5. Setting Up and Using the Equatorial Mount. . . . .	6
6. Using Your Telescope— Astronomical Observing . . . . .	11
7. Terrestrial Viewing. . . . .	14
8. Photography . . . . .	14
9. Care and Maintenance . . . . .	14
10. Specifications . . . . .	15

## 1. Unpacking

The entire telescope system will arrive in one box. Be careful unpacking the box. We recommend keeping the original shipping container. In the event that the telescope needs to be shipped to another location, or returned to Orion for warranty repair, having the proper shipping container will help ensure that your telescope will survive the journey intact.

Make sure all the parts in the Parts List are present. Be sure to check box carefully, as some parts are small. If anything appears to be missing or broken, immediately call Orion Customer Support (800-676-1343) or email support@telescope.com for assistance.

**WARNING:** *Never look directly at the Sun through your telescope or its finder scope—even for an instant—without a professionally made solar filter that completely covers the front of the instrument, or permanent eye damage could result. Young children should use this telescope only with adult supervision.*

## 2. Parts List

Qty.	Description
1	Optical tube assembly
1	Optical tube dust cover
1	25mm (62x) Sirius Plössl eyepiece (1.25")
1	Mirror star diagonal
1	6x26 correct-image finder scope
1	Polar axis finder scope
1	Dovetail finder scope bracket with O-ring
1	Equatorial mount
3	Tripod legs
1	Counterweight shaft
1	Large Counterweight
1	Small Counterweight
1	Tripod accessory tray
1	Accessory tray bracket
2	Slow-motion control cables
1	Soft carry case
3	Assembly tools (large and small wrench, Phillips head screwdriver)
2	Optical tube attachment knobs with lock washers and flat washers
1	Polar axis finder scope cover

## 3. Assembly

Assembling the telescope for the first time should take about 30 minutes. No tools are needed other than the ones provided. All screws should be tightened securely to eliminate flexing and wobbling, but be careful not to over-tighten or the threads may strip. Refer to Figure 1 during the assembly process.

During assembly (and anytime, for that matter), do not touch the surface of the telescope's meniscus lens or the lenses of the finder scopes or eyepiece with your fingers. The optical surfaces have delicate coatings on them that can easily be damaged if touched inappropriately. Never remove any lens



**Figure 2.** To adjust the latitude angle of the equatorial mount, loosen one of the two latitude adjustment T-bolts, then tighten the other.

assembly from its housing for any reason, or the product warranty and return policy will be voided.

1. Lay the equatorial mount on its side. Attach the tripod legs one at a time to the mount using the screws installed in the tops of the tripod legs. Remove the screw from the leg, line up the holes in the top of the leg with the holes in the base of the mount, and reinstall the screw so it passes through the leg and the mount. Tighten the wingnuts only finger-tight, for now. Note that the accessory tray bracket attachment point on each leg should face inward.

2. Tighten the leg lock knobs at the base of the tripod legs. For now, keep the legs at their shortest (fully retracted) length; you can extend them to a more desirable length later, after the scope is completely assembled.

3. With the tripod legs now attached to the equatorial mount, stand the tripod upright (be careful!) and spread the legs apart enough to connect each end of the accessory tray bracket to the attachment point on each leg. Use the screw that comes installed in each attachment point to do this. First remove the screw using the supplied screwdriver, then line up one of the ends of the bracket with the attachment point and reinstall the screw. Make sure the accessory tray bracket is oriented so that the ribs in its plastic molding face downward.

4. Now, with the accessory tray bracket attached, spread the tripod legs apart as far as they will go, until the bracket is taut. Attach the accessory tray to the bracket with the three wingnut-head screws already installed in the tray. Push the screws up through the holes in the bracket, then thread them into the holes in the tray.

5. Next, tighten the wingnuts at the top of the tripod legs, so the legs are securely fastened to the equatorial mount. Use the larger wrench and your fingers to do this.

6. Orient the equatorial mount as it appears in Figure 1, at a latitude of about  $40^\circ$ , i.e., so the pointer next to the latitude scale is pointing to the line at "40". To do this, loosen one of the latitude adjusting T-bolts and then tighten the other latitude

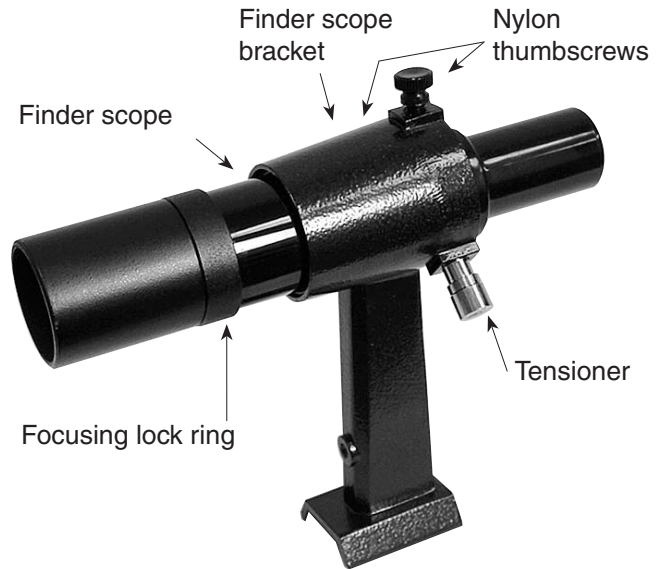

**Figure 3a.** The 6x26 Correct-Image finder scope



**Figure 3b.**

Pull back on the tensioner and slide the finder scope into its bracket until the O-ring is seated in the bracket ring

adjusting T-bolt until the pointer and the "40" line up (Figure 2). The declination (Dec.) and right ascension (R.A.) axes may need re-positioning (rotation) as well. Be sure to loosen the R.A. and Dec. lock levers before doing this. Retighten them once the equatorial mount is properly oriented.

7. Thread the counterweight shaft into the equatorial mount at the base of the declination axis until tight. Make sure the casting at the top of the bar is threaded clockwise as far as it will go before attaching the shaft.

8. Remove the knurled "toe saver" retaining screw on the bottom of the counterweight shaft and slide both counterweights onto the shaft. Make sure the counterweight lock knobs are adequately loosened to allow the counterweight shaft to pass through the hole. Position the counterweights about halfway up the shaft and tighten the lock knobs. Replace the toe saver on the end of the bar. It prevents the counterweights from falling on your foot if the lock knobs happen to come loose.

9. Connect the optical tube to the top of the mount with the optical tube attachment knobs. Place a lock washer on the shaft of each of the knobs, followed by a flat washer. Align the holes in the top of the mount with the holes in the mounting plate. Push

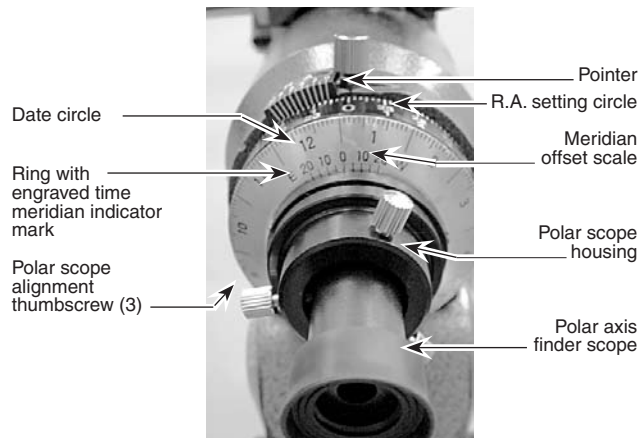

**Figure 4.** The polar axis finder scope installed in the right ascension (R.A.) axis of the mount.

the knobs, with washers attached, up through the holes in the mount and thread them into the plate until finger tight.

10. Attach the two slow-motion cables to the R.A. and Dec. worm gear shafts of the equatorial mount by positioning the small screw on the end of the cable over the indented slot on the worm gear shaft. Then tighten the screw.

11. To place the finder scope in the finder scope bracket, first unthread the two black nylon thumbscrews until the screw ends are flush with the inside diameter of the bracket. Place the O-ring that comes on the base of the bracket over the body of the finder scope until it seats into the groove on the middle of the finder scope. Slide the eyepiece end (narrow end) of the finder scope into the end of the bracket's cylinder opposite the alignment thumbscrews while pulling the chrome, spring-loaded tensioner on the bracket with your fingers (Figure 3b). Push the finder scope through the bracket until the O-ring seats just inside the front opening of the brackets cylinder. Now, release the tensioner and tighten the two black nylon thumbscrews a couple of turns each to secure the finder scope in place.

12. Insert the "foot" of the finder scope bracket into its mounting base on top of the optical tube. Lock the bracket into position by tightening the knurled thumbscrew on the base.

13. Insert the chrome barrel of the star diagonal into the eyepiece adapter and secure it with the thumbscrews.

14. Then insert the 25mm Plössl eyepiece into the star diagonal and secure it in place with the thumbscrews on the diagonal. (Always loosen the thumbscrews before rotating or removing the diagonal or an eyepiece.)

15. Install the polar axis finder scope into its housing inside the R.A. axis of the equatorial mount (Figure 4). First loosen the three thumbscrews on the housing, which is located at the rear of the R.A. axis. Insert the front end of the polar finder (the end without the eyeguard) into the housing so only about 1" of the polar finder extends from the back of the housing. Do this slowly and with a twisting motion to prevent the internal O-ring from becoming unseated. If it does become unseated, you can remove the entire housing from the mount to locate



**Figure 5a and 5b.** Proper operation of the equatorial mount requires balancing the telescope tube on the R.A. axis. (a) With the R.A. lock knob released, slide the counterweight along the counterweight shaft until it just counterbalances the tube. (b) When you let go with both hands, the tube should not drift up or down.

the O-ring and reseal it. This is done by rotating the entire housing counterclockwise. Once the polar axis finder scope is in the housing, tighten the three thumbscrews. These thumbscrews will be used later to align the finder with the mount's R.A. axis.

The telescope system is now fully assembled. Keep the dust cover over the front end of the telescope when it is not in use.

## 4. Getting Started

### Balancing the Telescope

To insure smooth movement of the telescope on both axes of motion (R.A. and Dec.) of the equatorial mount, it is imperative that the optical tube be properly balanced.

Keeping one hand on the telescope optical tube, loosen the R.A. lock lever. Make sure the Dec. lock lever is locked. The telescope should now be able to rotate freely about the R.A. axis. Rotate it until the counterweight shaft is parallel to the ground (i.e., horizontal).

Now loosen the counterweight lock knobs and slide the weights along the shaft until it exactly counterbalances the telescope (Figure 5a). That's the point at which the shaft remains horizontal even when you let go of the telescope with both hands (Figure 5b).

Retighten the counterweight lock knob.

---

The telescope is now balanced on the R.A. axis. It is not necessary to balance the telescope on the Dec. axis, since the optical tube's mounting plate is positioned so that the telescope will automatically be balanced on that axis. When you loosen the lock lever on one or both axes of motion and manually point the telescope, it should move without resistance and should not drift from where you point it.

### **Focusing the Telescope**

Point the telescope so the front end is aimed in the general direction of an object at least 1/4-mile away. With your fingers, slowly rotate the focusing knob until the object comes into sharp focus. Go a little bit beyond sharp focus until the image just starts to blur again, then reverse the rotation of the knob, just to make sure you've hit the exact focus point.

If you have trouble focusing, rotate the focus knob counter-clockwise as far as it will go. Look through the eyepiece while slowly rotating the focus knob clockwise. You should soon see the point at which focus is reached.

### **Do You Wear Eyeglasses?**

If you wear eyeglasses, you may be able to keep them on while you observe. In order to do this, your eyepiece must have enough "eye relief" to allow you to see the entire field of view with glasses on. You can try this by looking through the eyepiece first with your glasses on and then with them off, and see if the glasses restrict the view to only a portion of the full field. If the glasses do restrict the field of view, you may be able to observe with your glasses off by just refocusing the telescope the needed amount.

If your eyes are astigmatic, images will probably appear the best with glasses on. This is because a telescope's focuser can accommodate for nearsightedness or farsightedness, but not astigmatism. If you have to wear your glasses while observing and cannot see the entire field of view, you may want to purchase additional eyepieces that have longer eye relief.

### **Aligning the Finder Scope**

The finder scope must be aligned accurately with the telescope for proper use. To align it, aim the main telescope in the general direction of an object at least 1/4-mile away, such as the top of a telephone pole, a chimney, etc. Do this by first loosening the R.A. and Dec. lock levers. Position the telescope so the object appears in the eyepiece's field of view and then retighten the R.A. and Dec. lock levers. Use the slow-motion control cables to center the object in the eyepiece.

Now, look in the finder scope. Is the object visible? Ideally, it will be somewhere in the finder's field of view. If it is not, some coarse adjustments of the two black nylon finder scope alignment thumb screws will be needed to get the finder scope roughly parallel to the main tube.

**Note:** *The image in the telescope's eyepiece will appear inverted from left-to-right (mirror reversed), which is normal for telescopes that utilize a star diagonal. The image in the finder scope is oriented the same as the naked eye.*

By loosening or tightening the alignment thumbscrews, you change the line of sight of the finder scope. Continue making adjustments to the alignment thumbscrews until the image in both the finder scope and the telescope's eyepiece is exactly centered. Check the alignment by moving the telescope to another object and fixing the finder scope's crosshairs on the exact point you want to look at. Then look through the telescope's eyepiece to see if that point is centered in the field of view. If it is, the job is done. If not, make the necessary adjustments until the two images are centered simultaneously.

The finder scope alignment needs to be checked before every observing session. This can easily be done at night, before viewing through the telescope. Choose any bright star or planet, center the object in the telescope eyepiece, and then adjust the finder scope's alignment thumbscrews until the star or planet is also centered on the finder's crosshairs. The finder scope is an invaluable tool for locating objects in the night sky; its usage for this purpose will be discussed later, in detail.

### **Focusing the Finder Scope**

If, when looking through the finder scope, the images appear somewhat out of focus, you will need to refocus the finder scope for your eyes. Loosen the lock ring located behind the objective lens cell on the body of the finder scope (see Figure 3a). Back the lock ring off by a few turns, for now. Refocus the finder scope on a distant object by threading the objective lens cell in or out on the finder scope body. Precise focusing will be achieved by focusing the finder scope on a bright star. Once the image appears sharp, retighten the lock ring behind the objective lens cell. The finder scope's focus should not need to be adjusted again.

## **5. Setting Up and Using the Equatorial Mount**

When you look at the night sky, you no doubt have noticed that the stars appear to move slowly from east to west over time. That apparent motion is caused by the Earth's rotation (from west to east). An equatorial mount (Figure 6) is designed to compensate for that motion, allowing you to easily "track" the movement of astronomical objects, thereby keeping them from drifting out of the telescope's field of view while you're observing.

This is accomplished by slowly rotating the telescope on its right ascension (R.A.) axis, using only the R.A. slow-motion cable. But first the R.A. axis of the mount must be aligned with the Earth's rotational (polar) axis—a process called polar alignment.

### **Polar Alignment**

For Northern Hemisphere observers, approximate polar alignment is achieved by pointing the mount's R.A. axis at the North Star, or Polaris. It lies within 1° of the north celestial pole (NCP), which is an extension of the Earth's rotational axis out into space. Stars in the Northern Hemisphere appear to revolve around the NCP.

**Figure 6.** The equatorial mount of the StarMax 127mm EQ

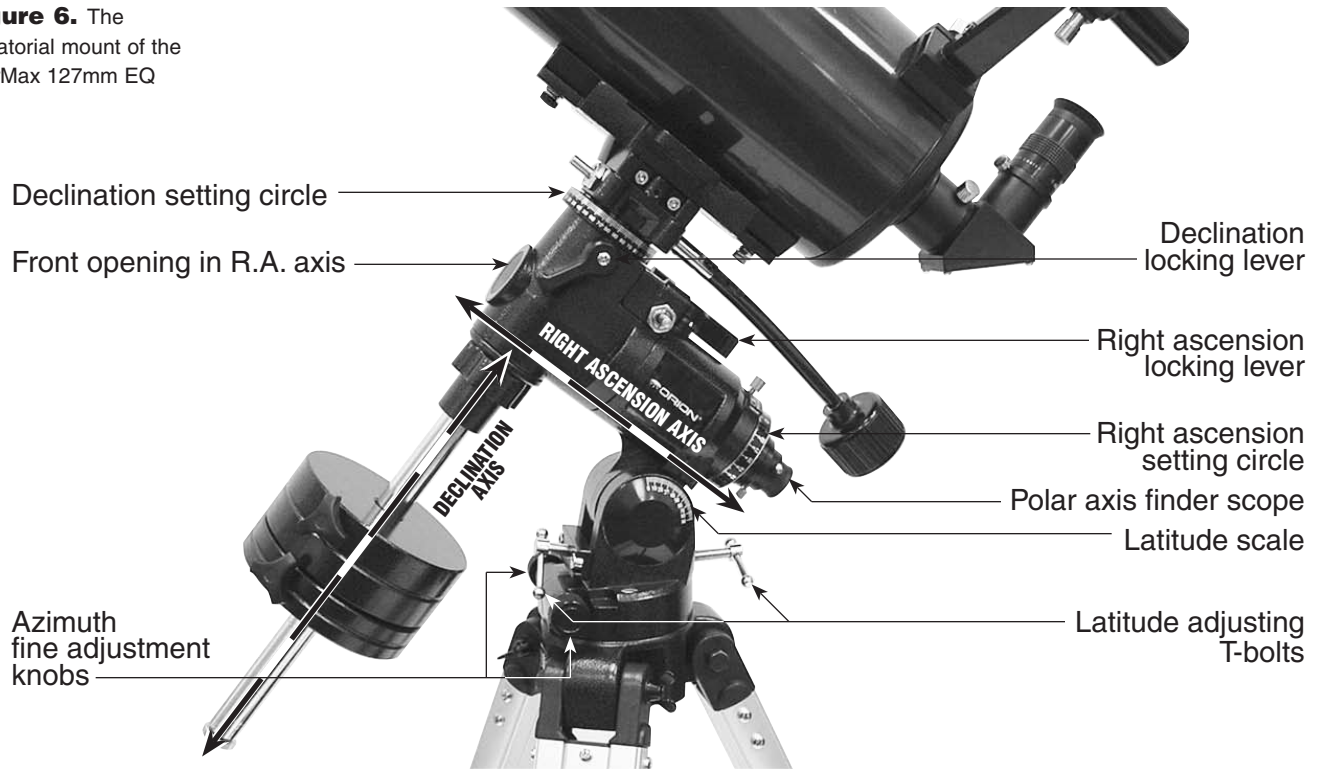

To find Polaris in the sky, look north and locate the pattern of the Big Dipper (Figure 7). The two stars at the end of the “bowl” of the Big Dipper point right to Polaris.

Observers in the Southern Hemisphere aren’t so fortunate to have a bright star so near the south celestial pole (SCP). The star Sigma Octantis lies about 1° from the SCP, but it is barely visible with the naked eye (magnitude 5.5).

For general visual observation, an approximate polar alignment is sufficient.

1. Level the equatorial mount by adjusting the length of the three tripod legs.
2. There are two altitude adjusting T-bolts (see Figure 6); loosen one bolt while tightening the other. By doing this you will adjust the latitude of the mount. Continue adjusting the mount until the pointer on the latitude scale is set at the latitude of your observing site. If you don’t know your latitude, consult a geographical atlas to find it. For example, if your latitude is 35° North, set the pointer to 35. The latitude setting should not have to be adjusted again unless you move to a different viewing location some distance away.
3. Loosen the Dec. lock lever and rotate the telescope optical tube until it is parallel with the R.A. axis, as it is in Figure 1. The pointer on the Dec. setting circle should read 90°. Retighten the Dec. lock lever.
4. Move the tripod so the telescope tube (and R.A. axis) points roughly at Polaris. If you cannot see Polaris directly from your observing site, consult a compass and rotate the tripod so the telescope points north. There is a label bearing a large “N” at

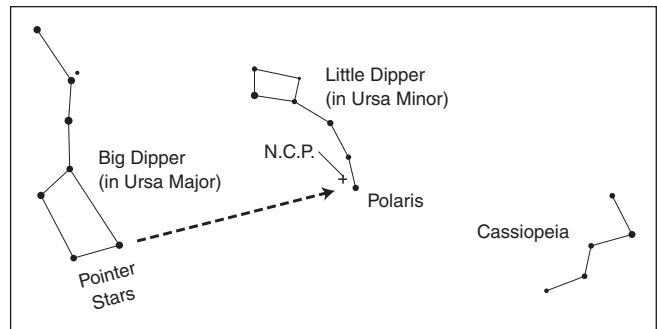
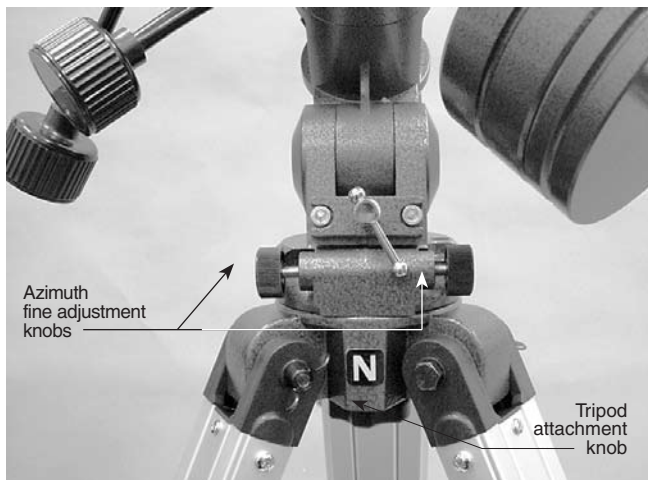

**Figure 7.** To find Polaris in the night sky, look north and find the Big Dipper. Extend an imaginary line from the two “Pointer Stars” in the bowl of the Big Dipper. Go about five times the distance between those stars and you’ll reach Polaris, which lies within 1° of the north celestial pole (NCP).

the base of the equatorial mount (Figure 8). It should be facing north.

The equatorial mount is now polar aligned for casual observing. More precise polar alignment is recommended for astrophotography.

From this point on in your observing session, you should not make any further adjustments in the azimuth or the latitude of the mount, nor should you move the tripod. Doing so will undo the polar alignment. The telescope should be moved only about its R.A. and Dec. axes.



**Figure 8.** For polar alignment, position the tripod so that the “N” label at the base of the mount faces north. The two azimuth fine adjustment knobs above it are used to make small adjustments to the mount’s azimuth position.

### The Polar Axis Finder Scope

A nice feature of the StarMax 127 EQ is the polar axis finder scope housed inside the R.A. axis of the equatorial mount (see Figure 4). When properly aligned and used, it makes accurate polar alignment quick and easy to do. Alignment of the polar finder need only be done once, unless it gets bumped or otherwise shifts its position.

Remove the round cover cap from the front opening in the R.A. axis of the mount (see Figure 6). Look through the polar finder at a distant object during the day. Focus the polar finder so that the images and reticle are sharp by rotating the eyepiece end of the finder. Notice that the reticle pattern consists of a crosshair with a circle around the middle. On the circumference of this circle is a tiny circle; this is where Polaris will be placed for accurate polar alignment once the finder is properly aligned. Alignment of the polar finder is best done during the day, before going out into the field at night.

### Aligning the Polar Axis Finder Scope

Aligning the polar axis finder scope so that it will accurately point at the true north pole is a two-step procedure. First, the polar finder must be rotated in its housing so that the small circle in which Polaris will be placed is in the proper initial position. Next, the polar axis finder must be adjusted so that it points directly along the mount’s R.A. axis.

We will start by aligning the polar finder rotationally. Refer to Figure 4.

1. Loosen the large thumbscrew just above the R.A. setting circle. Rotate the R.A. setting circle until the line above the “0” on the setting circle lines up with the pointed indicator that is cast into the mount (located directly below the large thumbscrew; see Figure 4). Retighten the thumbscrew.
2. Rotate the date circle until the “0” line on the meridian offset scale lines up with the time meridian indicator mark. The meridian offset scale is printed on the inner circumference of

the date circle, and is labeled “E20” to “W20”. The time meridian indicator mark is an engraved line on the exterior of the polar finder’s housing. It is on the “ring” of the housing that is closest to the date circle.

3. The R.A. setting circle is labeled in hours, from “0” to “23” (military time). For Northern Hemisphere observers, refer to the top numbers on the setting circle. Each small line represents 10 minutes of R.A. The date circle is labeled from “1” to “12”, with each number representing a month of the year (“1” is January, “2” is February, etc.). Each small line represents a two-day increment.

4. Loosen the R.A. lock lever and rotate the mount about the R.A. axis until the March 1 indicating mark (the long line between the “2” and the “3”) on the date circle lines up with the 4 PM mark (the long line above the “16”) on the R.A. setting circle. You may find it convenient to remove both the counterweights and the telescope optical tube to do this.

5. Now, loosen the three thumbscrews on the polar finder housing and rotate the polar finder so the small circle where Polaris will be centered is located straight down from the intersection of the crosshairs. Retighten the thumbscrews.

The polar axis finder scope is now properly set in its initial position. Next, we must align it so that it is exactly parallel to the mount’s R.A. axis:

6. Look through the polar finder at a distant object (during the day) and center it on the crosshairs. You may need to adjust the latitude adjustment T-bolts and the tripod position to do this.

7. Rotate the mount 180° about the R.A. axis. Again, it may be convenient to remove the counterweights and optical tube first.

8. Look through the polar finder again. Is the object being viewed still centered on the crosshairs? If it is, then no further adjustment is necessary. If not, then look through the polar finder while rotating the mount about the R.A. axis. You will notice that the object you have previously centered moves in a circular path. Use the three thumbscrews on the housing to redirect the crosshairs of the polar finder to the apparent center of this circular path. Repeat this procedure until the position that the crosshairs point to does not rotate off-center when the mount is rotated in R.A. Once this is accomplished, retighten the thumbscrews.

The polar axis finder scope is now ready to be used. When not in use, replace the plastic protective cover to prevent the polar finder from getting bumped, which could knock it out of alignment.

### Using the Polar Axis Finder

When using the polar finder in the field at night, you will need a red flashlight to illuminate the finder’s reticle. Shine the flashlight at an angle into the front opening in the R.A. axis. Do not shine it directly into the opening, or the light will be too bright, and you will also obstruct the view of the polar finder. It may be helpful to have a friend hold the flashlight while you look through the polar finder.



---

For most accurate polar alignment, you will need to know the approximate longitude of your observing site. This information can be obtained by looking at a local map. Now, you must figure the difference between the longitude of your observing site and the closest standard time meridian. The standard time meridians are 75°, 90°, 105°, and 120° for the 48 continental states (150° and 165° for Hawaii and Alaska). Choose the standard time meridian that is closest in value to your local longitude, and then calculate the difference.

If your local longitude has a value less than the closest standard time meridian, then you are east of the standard time meridian by the calculated amount. If your local longitude has a value greater than the closest standard time meridian, then you are west of the standard time meridian by the calculated amount. For example, if you are in Las Vegas, which has a longitude of 115°, then the closest standard time meridian is 120°. The difference between these two numbers is 5°. Since Las Vegas' longitude value is less than the standard time meridian value, you are 5° east of the closest time meridian.

Take your calculated difference from the closest standard time meridian and rotate the date circle so that the meridian offset scale line that corresponds to your calculated difference lines up with the engraved time meridian indicator mark on the polar finder housing. Each line of the meridian offset scale represents 5° of longitude. Lines to the left of the "0" on the meridian offset scale indicate east of the closest standard time meridian, while lines to the right of the "0" indicate west of the closest standard time meridian.

Continuing with the prior example of observing in Las Vegas, you would rotate the date circle so that the first line to the left of the "0" on the meridian offset scale lines up with the time meridian indicator mark.

Make sure that the "0" mark on the R.A. setting circle lines up with the pointed indicator cast into the mount, and that the large thumbscrew just above it is tightened. Now, rotate the mount about the R.A. axis until the line on the R.A. setting circle that corresponds to your current local time lines up with the line on the date circle that indicates the current date. If you are on daylight savings time, subtract one hour from your current local time.

For example, if it was November 1 at 9 PM, standard time, you would rotate the telescope in R.A. until the line above the "21" (9 P.M.) on the R.A. setting circle lines up with the long line between the "10" and "11" on the date circle. The long line indicates the first day of the higher numbered month, i.e. the line between "10" and "11" marks November 1st.

Finally, look through the polar alignment finder scope while shining a red flashlight at an angle down the front opening of the R.A. axis, and center Polaris in the small circle. Adjust the tilt of the altitude up-or-down with the latitude adjustment T-bolts and use the azimuth fine adjustment knobs (Figure 8) for final positioning. To do this, you will first need to loosen the big tripod attachment knob directly underneath the base of the equatorial mount. The fine adjustment knobs work by loosening one and then tightening the other. When done, retighten the tripod attachment knob to firmly secure the mount and tripod. If the fine adjustment knobs do not allow the mount to move far

enough to center Polaris, you will need to rotate the entire tripod left or right to get it within the fine adjustment's range.

Once Polaris is centered in the small circle, you are done. The telescope is now accurately polar aligned, and can be used for advanced observational applications, such as astrophotography or precise use of the manual setting circles. As mentioned before, only move the telescope along the R.A. and Dec. axes; if you move the tripod, or change the tilt of the equatorial mount, you will need to polar align again.

Remember, accurate polar alignment is not needed for casual visual observing. Most of the time, approximate polar alignment, as outlined previously, will suffice.

### **Use of the R.A. and Dec. Slow-Motion Control Cables**

The R.A. and Dec. slow-motion control cables allow fine adjustment of the telescope's position to center objects within the field of view. Before you can use the cables, you must manually "slew" the mount to point the telescope in the vicinity of the desired target. Do this by loosening the R.A. and Dec. lock levers and moving the telescope about the mount's R.A. and Dec. axes. Once the telescope is pointed somewhere close to the object to be viewed, retighten the mount's R.A. and Dec. lock levers.

The object should now be visible somewhere in the telescope's finder scope. If it isn't, use the slow-motion controls to scan the surrounding area of sky. When the object is visible in the finder scope, use the slow-motion controls to center it. Now, look in the telescope's eyepiece. If the finder scope is properly aligned, the object should be visible somewhere in the field of view. Once the object is visible in the eyepiece, use the slow-motion controls to center it in the field of view.

### **Tracking Celestial Objects**

When you observe a celestial object through the telescope, you'll see it drift slowly across the field of view. To keep it in the field, if your equatorial mount is polar aligned, just turn the R.A. slow-motion control cable clockwise. The Dec. slow-motion control cable is not needed for tracking. Objects will appear to move faster at higher magnifications, because the field of view is narrower.

### **Optional Motor Drives for Automatic Tracking**

An optional DC motor drive can be mounted on the R.A. axis of the equatorial mount to provide hands-free tracking. Objects will then remain stationary in the field of view without any manual adjustment of the R.A. slow-motion control cable.

### **Understanding the Setting Circles**

The setting circles on an equatorial mount enable you to locate celestial objects by their "celestial coordinates". Every object resides in a specific location on the "celestial sphere". That location is denoted by two numbers: its right ascension (R.A.) and declination (Dec.). In the same way, every location on Earth can be described by its longitude and latitude. R.A. is similar to longitude on Earth, and Dec. is similar to latitude.

---

The R.A. and Dec. values for celestial objects can be found in any star atlas or star catalog.

The R.A. setting circle is scaled in hours, from 1 through 24, with small marks in between representing 10 minute increments (there are 60 minutes in 1 hour of R.A.). The upper set of numbers apply to viewing in the Northern Hemisphere, while the numbers below them apply to viewing in the Southern Hemisphere. The location of the R.A. coordinate indicator arrow is shown in Figure 4.

The Dec. setting circle is scaled in degrees, with each mark representing 2° increments. Values of Dec. coordinates range from +90° to -90°. The 0° mark indicates the celestial equator. When the telescope is pointed north of the celestial equator, values of the Dec. setting circle are positive; when the telescope is pointed south of the celestial equator, values of the Dec. setting circle are negative.

So, the coordinates for the Orion Nebula listed in a star atlas will look like this:

**R.A. 5h 35.4m Dec.—5° 27'**

That's 5 hours and 35.4 minutes in right ascension, and -5 degrees and 27 arc-minutes in declination (there are 60 arc-minutes in 1 degree of declination).

Before you can use the setting circles to locate objects, the mount must be well polar aligned, and the R.A. setting circle must be calibrated. The Dec. setting circle has been calibrated at the factory, and should read 90° whenever the telescope optical tube is parallel with the R.A. axis.

### **Calibrating the Right Ascension Setting Circle**

1. Identify a bright star in the sky near the celestial equator (Dec. = 0°) and look up its coordinates in a star atlas.
2. Loosen the R.A. and Dec. lock levers on the equatorial mount, so the telescope optical tube can move freely.
3. Point the telescope at the bright star whose coordinates you know. Lock the R.A. and Dec. lock levers. Center the star in the telescope's field of view with the slow-motion control cables.
4. Loosen the R.A. setting circle lock thumbscrew (see Figure 4); this will allow the setting circle to rotate freely. Rotate the setting circle until the arrow under the thumbscrew indicates the R.A. coordinate listed in the star atlas for the object. Do not retighten the thumbscrew when using the R.A. setting circles for finding objects; the thumbscrew is only needed for polar alignment using the polar axis finder scope.

### **Finding Objects With the Setting Circles**

Now that both setting circles are calibrated, look up in a star atlas the coordinates of an object you wish to view.

1. Loosen the Dec. lock lever and rotate the telescope until the Dec. value from the star atlas matches the reading on the Dec. setting circle. Remember that values of the Dec. setting circle are positive when the telescope is pointing north of the celestial equator (Dec. = 0°), and negative when the telescope

is pointing south of the celestial equator. Retighten the lock lever.

2. Loosen the R.A. lock lever and rotate the telescope until the R.A. value from the star atlas matches the reading on the R.A. setting circle. Remember to use the upper set of numbers on the R.A. setting circle. Retighten the lock lever.

Most setting circles are not accurate enough to put an object dead-center in the telescope's eyepiece, but they should place the object somewhere within the field of view of the finder scope, assuming the equatorial mount is accurately polar aligned. Use the slow-motion controls to center the object in the finder scope, and it should appear in the telescope's field of view.

The R.A. setting circle must be re-calibrated every time you wish to locate a new object. Do so by calibrating the setting circle for the centered object before moving on to the next one.

### **Confused About Pointing the Telescope?**

Beginners occasionally experience some confusion about how to point the telescope overhead or in other directions. In Figure 1 the telescope is pointed north, as it would be during polar alignment. The counterweight shaft is oriented downward. But it will not look like that when the telescope is pointed in other directions. Let's say you want to view an object that is directly overhead, at the zenith. How do you do it?

One thing you DO NOT do is make any adjustment to the latitude adjustment T-bolts. That will nullify the mount's polar alignment. Remember, once the mount is polar aligned, the telescope should be moved only on the R.A. and Dec. axes. To point the scope overhead, first loosen the R.A. lock lever and rotate the telescope on the R.A. axis until the counterweight shaft is horizontal (parallel to the ground). Then loosen the Dec. lock lever and rotate the telescope until it is pointing straight overhead. The counterweight shaft is still horizontal. Then retighten both lock levers.

Similarly, to point the telescope directly south, the counterweight shaft should again be horizontal. Then you simply rotate the scope on the Dec. axis until it points in the south direction.

What if you need to aim the telescope directly north, but at an object that is nearer to the horizon than Polaris? You can't do it with the counterweight down as pictured in Figure

Again, you have to rotate the scope in R.A. so the counterweight shaft is positioned horizontally. Then rotate the scope in Dec. so it points to where you want it near the horizon.

To point the telescope to the east or west, or in other directions, you rotate the telescope on its R.A. and Dec. axes. Depending on the altitude of the object you want to observe, the counterweight shaft will be oriented somewhere between vertical and horizontal.

Figure 9 illustrates how the telescope will look pointed at the four cardinal directions—north, south, east, and west.

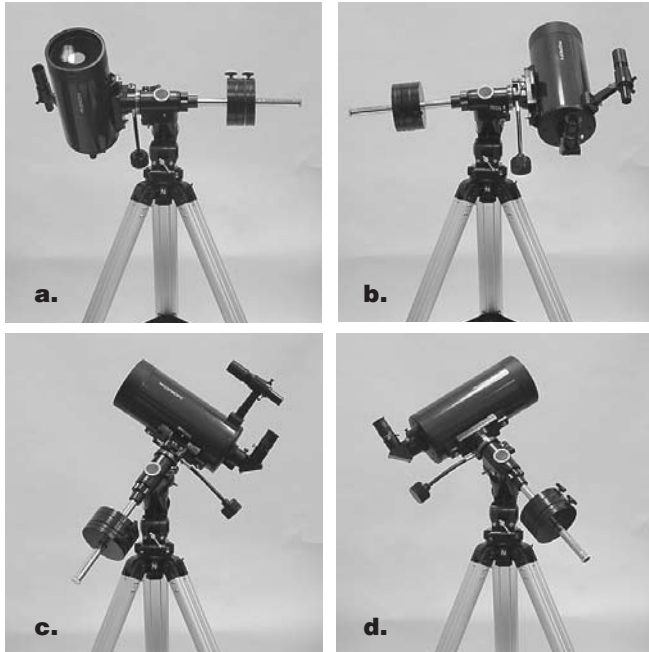

**Figure 9.** This illustration shows the telescope pointed in the four cardinal directions: (a) north, (b) south, (c) east, (d) west. Note that the tripod and mount have not been moved; only the telescope tube has been moved on the R.A. and Dec. axes.

The key things to remember when pointing the telescope are, first that you only move it in R.A. and Dec., not in azimuth or latitude (altitude), and second, the counterweight and shaft will not always appear as it does in Figure 1. In fact, it almost never will!

## 6. Using Your Telescope—Astronomical Observing

### Choosing an Observing Site

When selecting a location for observing, get as far away as possible from direct artificial light such as street lights, porch lights, and automobile headlights. The glare from these lights will greatly impair your dark-adapted night vision. Set up on a grass or dirt surface, not asphalt, because asphalt radiates more heat. Heat disturbs the surrounding air and degrades the images seen through the telescope. Avoid viewing over rooftops and chimneys, as they often have warm air currents rising from them. Similarly, avoid observing from indoors through an open (or closed) window, because the temperature difference between the indoor and outdoor air will cause image blurring and distortion.

If at all possible, escape the light-polluted city sky and head for darker country skies. You'll be amazed at how many more stars and deep-sky objects are visible in a dark sky!

### “Seeing” and Transparency

Atmospheric conditions vary significantly from night to night. “Seeing” refers to the steadiness of the Earth’s atmosphere at a given time. In conditions of poor seeing, atmospheric turbulence causes objects viewed through the telescope to “boil”. If, when you look up at the sky with just your eyes, the stars are twinkling noticeably, the seeing is bad and you will be limited to viewing with low powers (bad seeing affects images at high powers more severely). Planetary observing may also be poor.

In conditions of good seeing, star twinkling is minimal and images appear steady in the eyepiece. Seeing is best overhead, worst at the horizon. Also, seeing generally gets better after midnight, when much of the heat absorbed by the Earth during the day has radiated off into space.

Especially important for observing faint objects is good “transparency”—air free of moisture, smoke, and dust. All tend to scatter light, which reduces an object’s brightness. Transparency is judged by the magnitude of the faintest stars you can see with the unaided eye (6th magnitude or fainter is desirable).

### Cooling the Telescope

All optical instruments need time to reach “thermal equilibrium”. The bigger the instrument and the larger the temperature change, the more time is needed. Allow at least 30 minutes for your telescope to cool to the temperature outdoors. In very cold climates (below freezing), it is essential to store the telescope as cold as possible. If it has to adjust to more than a 40° temperature change, allow at least one hour.

### Let Your Eyes Dark-Adapt

Don’t expect to go from a lighted house into the darkness of the outdoors at night and immediately see faint nebulae, galaxies, and star clusters—or even very many stars, for that matter. Your eyes take about 30 minutes to reach perhaps 80% of their full dark-adapted sensitivity. As your eyes become dark-adapted, more stars will glimmer into view and you’ll be able to see fainter details in objects you view in your telescope.

To see what you’re doing in the darkness, use a red-filtered flashlight rather than a white light. Red light does not spoil your eyes’ dark adaptation like white light does. A flashlight with a red LED light is ideal, or you can cover the front of a regular incandescent flashlight with red cellophane or paper. Beware, too, that nearby porch and streetlights and car headlights will ruin your night vision.

### Eyepiece Selection

By using eyepieces of varying focal lengths, it is possible to attain many magnifications with the StarMax 127mm EQ. The telescope comes with one high-quality 25mm Sirius Plössl, which gives a magnification of 62x. Other eyepieces can be used to achieve higher or lower powers. It is quite common for an observer to own five or more eyepieces to access a wide range of magnifications. This allows the observer to choose

---

the best eyepiece to use depending on the object being viewed.

To calculate the magnification, or power, of a telescope and eyepiece combination, simply divide the focal length of the telescope by the focal length of the eyepiece:

$$\text{Magnification} = \frac{\text{focal length of telescope}}{\text{focal length of eyepiece}}$$

For example, the StarMax 127mm EQ, which has a focal length of 1540mm, used in combination with the 25mm eyepiece, yields a power of

$$1540\text{mm} \div 25\text{mm} = 62\text{x}$$

Every telescope has a useful limit of power of about 2x per mm of aperture (about 254x for the StarMax 127mm EQ). Claims of higher power by some telescope manufacturers are a misleading advertising gimmick and should be dismissed. Keep in mind that at higher powers, an image will always be dimmer and less sharp (this is a fundamental law of optics). The steadiness of the air (the “seeing”) will also limit how much magnification an image can tolerate.

Whatever you choose to view, always start by inserting your lowest-power (longest focal length) eyepiece to locate and center the object. Low magnification yields a wide field of view, which shows a larger area of sky in the eyepiece. This makes acquiring and centering an object much easier. If you try to find and center objects with high power (narrow field of view), it’s like trying to find a needle in a haystack!

Once you’ve centered the object in the eyepiece, you can switch to higher magnification (shorter focal length eyepiece), if you wish. This is especially recommended for small and bright objects, like planets and double stars. The Moon also takes higher magnifications well.

Deep-sky objects, however, typically look better at medium or low magnifications. This is because many of them are quite faint, yet have some extent (apparent width). Deep-sky objects will often disappear at higher magnifications, since greater magnification inherently yields dimmer images. This is not the case for all deep-sky objects, however. Many galaxies are quite small, yet are somewhat bright, so higher power may show more detail.

The best rule of thumb with eyepiece selection is to start with a low power, wide field, and then work your way up in magnification. If the object looks better, try an even higher magnification. If the object looks worse, then back off the magnification a little by using a lower-power eyepiece.

### Rotating the Diagonal

When looking at objects in different areas of the night sky, the eyepiece may become positioned so that is uncomfortable or impossible to look through. If the eyepiece is in an undesirable position, the diagonal can be rotated in order to provide a more comfortable viewing angle. First, loosen the thumbscrews on the eyepiece adapter, but make sure to hold the diagonal in place so that it won’t fall to the ground. Also, secure the eyepiece in the diagonal so that it won’t fall out when rotating the diagonal. Retighten the thumbscrews on

the eyepiece adapter once the diagonal has been rotated to an appropriate position.

## Objects to Observe

Now that you are all set up and ready to go, one critical decision must be made: what to look at?

### A. The Moon

With its rocky surface, the Moon is one of the easiest and most interesting targets to view with your telescope. Lunar craters, marias, and even mountain ranges can all be clearly seen from a distance of 238,000 miles away! With its ever-changing phases, you’ll get a new view of the Moon every night. The best time to observe our one and only natural satellite is during a partial phase, that is, when the Moon is NOT full. During partial phases, shadows are cast on the surface, which reveal more detail, especially right along the border between the dark and light portions of the disk (called the “terminator”). A full Moon is too bright and devoid of surface shadows to yield a pleasing view. Make sure to observe the Moon when it is well above the horizon to get the sharpest images.

Use an optional Moon filter to dim the Moon when it is very bright. It simply threads onto the bottom of the eyepieces (you must first remove the eyepiece from the focuser to attach a filter). You’ll find that the Moon filter improves viewing comfort, and also helps to bring out subtle features on the lunar surface.

### B. The Sun

You can change your nighttime telescope into a daytime Sun viewer by installing an optional full-aperture solar filter over the front opening of the StarMax 127mm EQ. Leave the cover caps on the finder scope or, better yet, completely remove the finder scope when solar viewing. The primary attraction is sunspots, which change shape, appearance, and location daily. Sunspots are directly related to magnetic activity in the Sun. Many observers like to make drawings of sunspots to monitor how the Sun is changing from day to day.

**Important Note: Do not look at the Sun with any optical instrument without a professionally made solar filter, or permanent eye damage could result.**

### C. The Planets

The planets don’t stay put like the stars, so to find them you should refer to Sky Calendar at our website (telescope.com), or to charts published monthly in Astronomy, Sky & Telescope, or other astronomy magazines. Venus, Mars, Jupiter, and Saturn are the brightest objects in the sky after the Sun and the Moon. Your StarMax 127mm EQ is capable of showing you these planets in some detail. Other planets may be visible but will likely appear star-like. Because planets are quite small in apparent size, optional higher-power eyepieces are recommended and often needed for detailed observations. Not all the planets are generally visible at any one time.

**JUPITER** The largest planet, Jupiter, is a great subject for observation. You can see the disk of the giant planet and watch the ever-changing positions of its four largest moons—

Io, Callisto, Europa, and Ganymede. Higher-power eyepieces should bring out the cloud bands on the planet's disk.

**SATURN** The ringed planet is a breathtaking sight when it is well positioned. The tilt angle of the rings varies over a period of many years; sometimes they are seen edge-on, while at other times they are broadside and look like giant “ears” on each side of Saturn’s disk. A steady atmosphere (good seeing) is necessary for a good view. You will probably see a bright “star” close by, which is Saturn’s brightest moon, Titan.

**VENUS** At its brightest, Venus is the most luminous object in the sky, excluding the Sun and the Moon. It is so bright that sometimes it is visible to the naked eye during full daylight! Ironically, Venus appears as a thin crescent, not a full disk, when at its peak brightness. Because it is so close to the Sun, it never wanders too far from the morning or evening horizon. No surface markings can be seen on Venus, which is always shrouded in dense clouds.

**MARS** The Red Planet makes its closest approach to Earth every two years. During close approaches you’ll see a red disk, and may be able to see the polar ice cap. To see surface detail on Mars, you will need a high-power eyepiece and very steady air!

#### D. The Stars

Stars will appear like twinkling points of light. Even powerful telescopes cannot magnify stars to appear as more than a point of light. You can, however, enjoy the different colors of the stars and locate many pretty double and multiple stars. The famous “Double-Double” in the constellation Lyra and the gorgeous two-color double star Albireo in Cygnus are favorites. Defocusing a star slightly can help bring out its color.

#### E. Deep-Sky Objects

Under dark skies, you can observe a wealth of fascinating deep-sky objects, including gaseous nebulas, open and globular star clusters, and a variety of different types of galaxies. Most deep-sky objects are very faint, so it is important that you find an observing site well away from light pollution. Take plenty of time to let your eyes adjust to the darkness. Do not expect these subjects to appear like the photographs you see in books and magazines; most will look like dim gray smudges. Our eyes are not sensitive enough to see color in deep-sky objects except in a few of the brightest ones. But as you become more experienced and your observing skills get sharper, you will be able to ferret out more and more subtle details and structure.

#### How to Find Deep-Sky Objects: Star Hopping

Star hopping, as it is called by astronomers, is perhaps the simplest way to hunt down deep-sky objects to view in the night sky. It entails first pointing the telescope at a bright star close to the object you wish to observe, and then progressing to other stars closer and closer to the object until it is in the field of view of the eyepiece. It is a very intuitive technique that has been employed for hundreds of years by professional and amateur astronomers alike. Keep in mind, as with any new task, that star hopping may seem challenging at first, but will become easier over time and with practice.

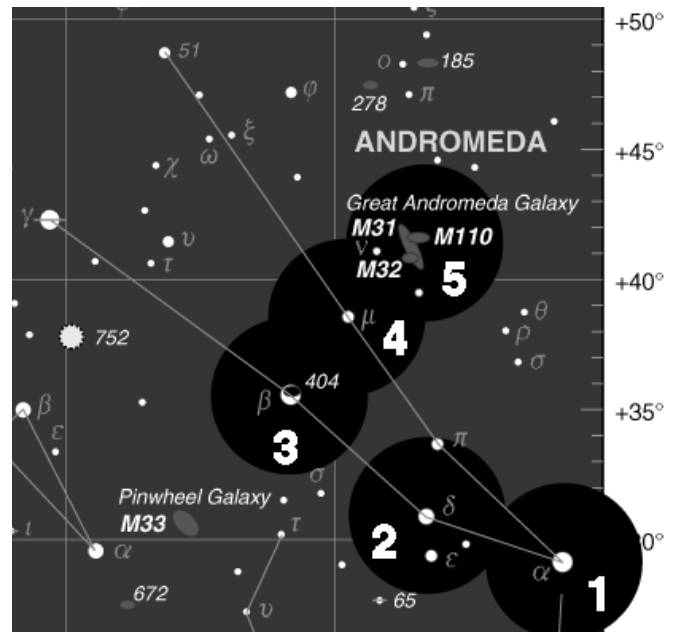

**Figure 10.** Star hopping is a good way to locate hard-to-find objects. Refer to a star chart to map a route to the object that uses bright stars as guideposts. Center the first star you’ve chosen in the finder scope and telescope eyepiece (1). Now move the scope carefully in the direction of the next bright star (2), until it is centered. Repeat (3 and 4). The last hop (5) should place the desired object in the eyepiece.

To star hop, only a minimal amount of additional equipment is necessary. A star chart or atlas that shows stars to at least magnitude 5 is required. Select one that shows the positions of many deep-sky objects, so you will have a lot of options to choose from. If you do not know the positions of the constellations in the night sky, you will need a planisphere to identify them.

Start by choosing bright objects to view. The brightness of an object is measured by its visual magnitude; the brighter an object, the lower its magnitude. Choose an object with a visual magnitude of 9 or lower. Many beginners start with the Messier objects, which represent some of the best and brightest deep-sky objects, first catalogued about 200 years ago by the French astronomer Charles Messier.

Determine in which constellation the object lies. Now, find the constellation in the sky. If you do not recognize the constellations on sight, consult a planisphere. The planisphere gives an all-sky view and shows which constellations are visible on a given night at a given time.

Now, look at your star chart and find the brightest star in the constellation that is near the object you are trying to find. Using the finder scope, point the telescope at this star and center it on the crosshairs. Next, look again at the star chart and find another suitably bright star near the bright star currently centered in the finder. Keep in mind that the field of view of the finder scope is about 6°, so you should choose another star that is no more than 6° from the first star, if possible. Move

---

the telescope slightly, until the telescope is centered on the new star.

Continue using stars as guideposts in this way until you are at the approximate position of the object you are trying to find (Figure 10). Look in the telescope's eyepiece, and the object should be somewhere within the field of view. If it's not, sweep the telescope carefully around the immediate vicinity until the object is found.

If you have trouble finding the object, start the star hop again from the brightest star near the object you wish to view. This time, be sure the stars indicated on the star chart are in fact the stars you are centering in the eyepiece.

## 7. Terrestrial Viewing

The StarMax 127mm not only excels at astronomical observing, it's great for terrestrial (land) viewing too. The equatorial mount, however, is not well suited for land viewing due to its motion about R.A. and Dec. axes instead of altitude (vertical) and azimuth (horizontal) axes. Because of this, we recommend removing the optical tube from the EQ-3 Mount and placing it on an appropriate photo-style tripod. To do this, loosen the two optical tube attachment knobs until the optical tube is freed from the mount. Make sure to have a firm grip on the tube as it releases from the mount. Now, connect the optical tube to a photo tripod by threading the tripod's 1/4"-20 shaft into a hole in the tube's mounting plate. Choose the hole that will best balance the tube; this will vary depending on the accessories being used.

The included mirror star diagonal, while preferred for astronomical observing because of its viewing angle and better resolution, is not optimal for land viewing because it inverts images from left-to-right. We recommend purchasing an optional 45° correct-image diagonal for terrestrial observing; it provides a more comfortable viewing angle for land viewing and an image that is oriented the same as the naked eye.

For terrestrial viewing, it's best to stick with low power eyepieces that yield a magnification under 100x. At higher powers, images rapidly lose sharpness and clarity due to "heat waves" caused by Sun-heated air.

Remember to aim well clear of the Sun, unless the front of the telescope is fitted with a professionally made solar filter and the finder scope is covered with foil or some other completely opaque material.

## 8. Photography

With an optional camera adapter, the StarMax 127mm becomes a 1540mm f/12.1 telephoto lens for a single-lens reflex camera. For long-distance terrestrial or astronomical photography, you need only a T-ring for your specific camera model. The T-ring attaches to your camera and threads onto the StarMax's eyepiece adapter (first remove eyepiece and diagonal), coupling the camera body to the telescope.

Use the camera's viewfinder to frame the picture. Use the telescope's focuser to focus the image.

You may want to consider using a remote shutter release instead of the shutter release on the camera. Touching the camera can vibrate the system and blur the resulting photographic image. Also, be sure to use a solid tripod.

## 9. Care and Maintenance

### Transporting

The included soft carry case provides an excellent way to transport the optical tube and its accessories. To remove the optical tube loosen the two optical tube attachment knobs until the optical tube is freed from the mount. Make sure to have a firm grip on the tube as it releases from the mount. To place the optical tube in the case, the eyepiece, diagonal, finder scope and bracket must be removed from the tube. When removing the eyepiece and diagonal, remember to first loosen the securing thumbscrews. The finder scope and bracket can be removed together by loosening the thumbscrew on the tube's mounting base. Cover the front of the optical tube with the dust cover and the rear opening of the eyepiece adapter with its cap. Now place the tube in the case's main compartment underneath the padded divider. The finder scope and bracket can be placed on top of the divider as one unit. The eyepiece and diagonal should be placed in the external compartments of the case.

It is not necessary to completely disassemble the mount to transport it. It will be convenient to remove the accessory tray (by unthreading the three wing screws) in order to fold the tripod legs together. It may also be convenient to remove the slow-motion control cables and counterweight shaft. Orion offers an optional Padded Scope Case that will fit the entire EQ-3 Mount.

### Storing

If you give your telescope reasonable care, it will last a lifetime. Store it in a clean, dry, dust-free place, safe from rapid changes in temperature and humidity. Do not store the telescope outdoors, although storage in a garage or shed is OK. Small components like eyepieces, diagonals, and other accessories can be kept in the included carry case or in an optional eyepiece case. Keep the dust cover on the front of the telescope and cap the rear opening of the eyepiece adapter. Also keep the finder scope caps on if you leave it attached to the optical tube.

### Cleaning the Tube

Your StarMax 127mm EQ telescope requires very little mechanical maintenance. The optical tube is aluminum and has a smooth painted finish that is fairly scratch-resistant. If a scratch does appear on the tube, it will not harm the telescope. If you wish, you may apply some auto touch-up paint to the scratch. Smudges on the tube can be wiped off with a soft cloth and a household cleaner such as Windex or Formula 409.

## Cleaning Lenses

Any quality optical lens cleaning tissue and optical lens cleaning fluid specifically designed for multi-coated optics can be used to clean the StarMax's front meniscus lens or exposed lenses of your eyepieces or finder scope. Never use regular glass cleaner or cleaning fluid designed for eyeglasses. Before cleaning with fluid and tissue, however, blow any loose particles off the lens with a blower bulb or compressed air. Then apply some cleaning fluid to a tissue, never directly on the optics. Wipe the lens gently in a circular motion, then remove any excess fluid with a fresh lens tissue. Oily fingerprints and smudges may be removed using this method. Use caution; rubbing too hard may scratch the lens. For the large surface of the meniscus lens, clean only a small area at a time, using a fresh lens tissue on each area. Never reuse tissues.

## 10. Specifications

Optical design: Maksutov-Cassegrain

Aperture: 127mm

Effective focal length: 1540mm

Focal ratio: f/12.1

Central obstruction diameter: 39mm

Primary mirror coating: Aluminum with overcoat

Meniscus lens coating: Anti-reflection multi-coatings on both sides of lens

Eyepiece adapter: Accepts 1.25" accessories, camera T-threads

Eyepiece: 25mm Sirius Plössl, fully coated with multi-coatings, 1.25" format

Magnification with supplied eyepiece: 62x

Actual field of view with supplied eyepiece: 0.77°

Diagonal: 90° mirror star diagonal, 1.25" format

Near focus (with supplied eyepiece & diagonal): 27 feet

Finder scope: 6x magnification, 26mm aperture, correct-image, achromatic, 6.3° field

Finder scope bracket: Dovetail mounting, spring-loaded X-Y alignment

Optical tube mounting plate: Fits standard photo-style tripods and EQ-3 equatorial mount

Mount: EQ-3, German-type equatorial

Slow-motion controls: R.A. and Dec. axes

Setting Circles: R.A. scaled in 10 minute increments, Dec. scaled in 2° increments

Counterweights: 4.0 lbs and 7.5 lbs

Tripod: Adjustable-height aluminum legs, accessory tray included

Case: Deluxe carry case for optical tube included, padded case for EQ-3 mount optional

Motor drives: Optional

Weight: 36.6 lbs (tube 8.6 lbs, mount 28.lbs)

## One-Year Limited Warranty

This Orion StarMax 127mm EQ™ is warranted against defects in materials or workmanship for a period of one year from the date of purchase. This warranty is for the benefit of the original retail purchaser only. During this warranty period Orion Telescopes & Binoculars will repair or replace, at Orion's option, any warranted instrument that proves to be defective, provided it is returned postage paid to: Orion Warranty Repair, 89 Hangar Way, Watsonville, CA 95076. If the product is not registered, proof of purchase (such as a copy of the original invoice) is required.

This warranty does not apply if, in Orion's judgment, the instrument has been abused, mishandled, or modified, nor does it apply to normal wear and tear. This warranty gives you specific legal rights, and you may also have other rights, which vary from state to state. For further warranty service information, contact: Customer Service Department, Orion Telescopes & Binoculars, 89 Hangar Way, Watsonville, CA 95076; (800) 676-1343.

## Orion Telescopes & Binoculars

89 Hangar Way, Watsonville, CA 95076

Customer Support Help Line (800) 676-1343 • Day or Evening