

# INSTRUCTION MANUAL

# Orion® SkyQuest™ XT12 Classic

#9966 Dobsonian Reflecting Telescope



**ORION**  
**TELESCOPES & BINOCULARS**  
*Providing Exceptional Consumer Optical Products Since 1975*

**Customer Support (800) 676-1343**

**E-mail: [support@telescope.com](mailto:support@telescope.com)**

Corporate Offices (831) 763-7000

P.O. Box 1815, Santa Cruz, CA 95061

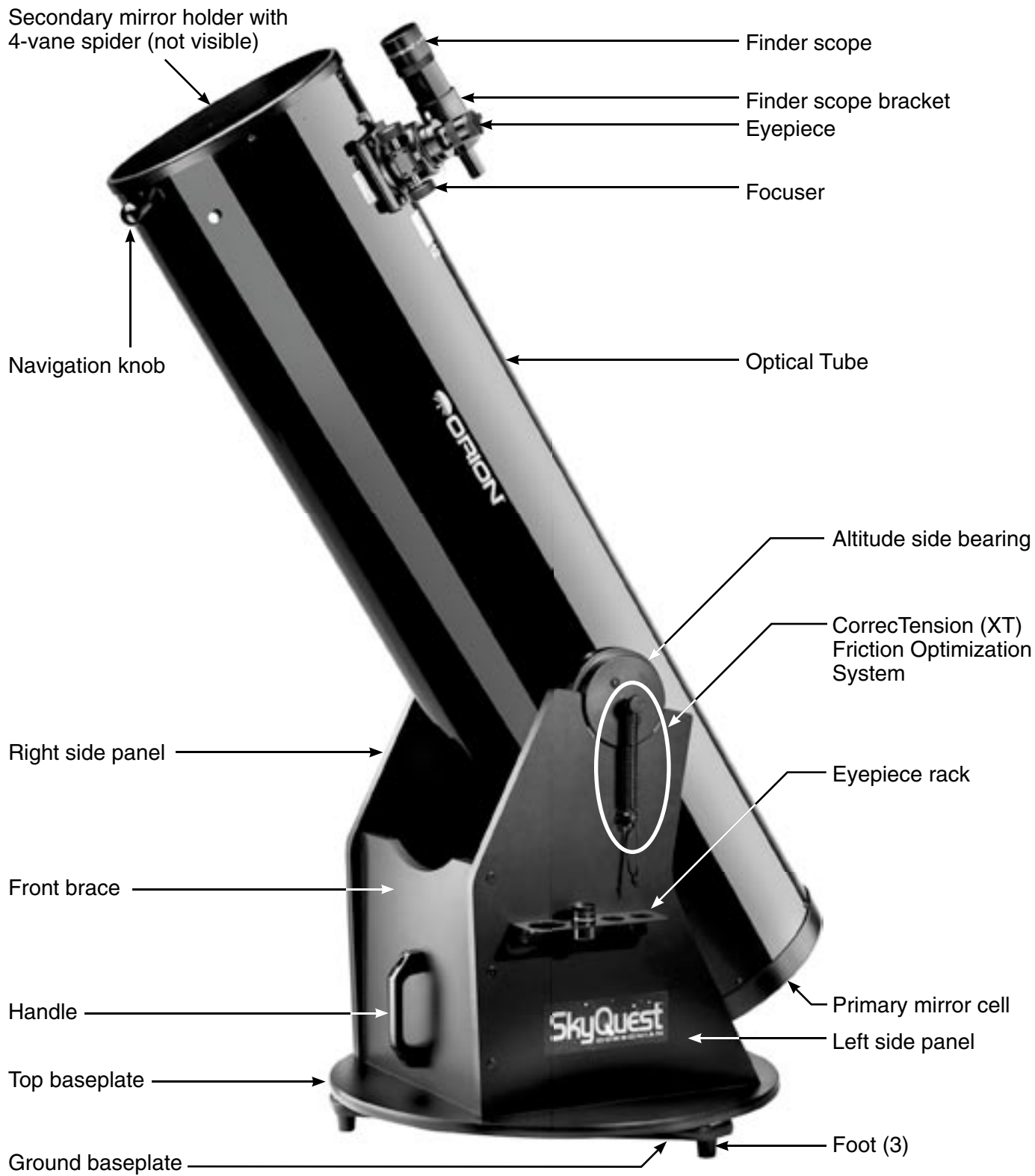

**Figure 1.** The SkyQuest XT12 Classic Dobsonian.

Welcome to an exciting new world of adventure! Your SkyQuest XT12 Dobsonian is a high-quality optical instrument designed to bring you dazzling views of the outer reaches of our universe. With special new innovations, such as the CorrecTension (XT) Friction Optimization system, large format focuser, and deluxe accessory package, this telescope represents a giant leap forward in the evolution of the Dobsonian. Whether you are brand-new to amateur astronomy or a seasoned stargazer, the SkyQuest XT12 Dobsonian will provide many evenings of enjoyment and fascination.

## Table of Contents

1. Unpacking .....	3
2. Assembly .....	4
3. Using Your Telescope .....	8
4. Collimation (Aligning the Mirrors) .....	11
5. Astronomical Observing .....	13
6. Care and maintenance .....	17
7. Specifications .....	17

## 1. Unpacking

The telescope will arrive in three boxes, one containing the optical tube assembly and accessories, another containing the unassembled Dobsonian base, and the last containing the primary mirror in its cell. Be careful unpacking the boxes. We recommend keeping the original shipping containers. In the event that the telescope needs to be shipped to another location, or returned to Orion for warranty repair, having the proper shipping containers will help ensure your telescope will survive the journey intact.

Make sure all the parts in the Parts List are present. Be sure to check boxes carefully, as some parts are small. If anything appears to be missing or broken, immediately call Orion Customer Support (800-676-1343) or email sales@telescope.com for assistance.

## Parts List

### Box #1: Optical Tube Assembly and Accessories

Qty.	Description
1	Optical tube assembly
1	Dust cover

**WARNING:** *Never look directly at the Sun through your telescope or its finder scope—even for an instant—without a professionally made solar filter that completely covers the front of the instrument, or permanent eye damage could result. Young children should use this telescope only with adult supervision.*

1	25mm Sirius Plössl eyepiece
1	10mm Sirius Plössl eyepiece
1	9x50 finder scope
1	Finder scope bracket with O-ring
1	4-hole eyepiece rack
1	Collimation cap
2	Eyepiece rack mounting wood screws (length 3/4")
2	Spring coils
2	Pull loops
4	Nylon spacers (black)
2	1/4" washers (black)
2	Phillips-head screws (black, length 1-3/4")
2	Screws with round knobs attached

### Box #2: Dobsonian Base

Qty.	Description
1	Left panel
1	Right panel
1	Front brace
1	Top baseplate
1	Ground baseplate
12	Base assembly screws (length 2")
1	Hex key (4mm)
3	Plastic feet
3	Feet attachment wood screws (length 1")
1	Self-adhesive rubber bumper
1	Large hex-head screw (length 3")
2	3/8" washers
1	3/8" lock nut
1	Nylon spacer (white)
1	T-nut
1	Handle
2	Socket head cap screws, 5/16" (black)
2	5/16" washers (black)
2	5/16" nuts (black)
1	Hex key (6mm)



**Figure 2.** To remove the rear end ring, unthread the six screws that connect it to the tube.

**Box #3: Primary Mirror and Cell**

Qty.	Description
1	Primary mirror
1	Mirror cell
3	Collimation knobs
3	Nylon washers
3	Springs

**2. Assembly**

Now that you have unpacked the boxes and familiarized yourself with all the parts in front of you, it's time to begin assembly.

**Assembly of the Optical Tube**

In order to prevent damage to the primary mirror in shipment, it is shipped in its cell separately from the optical tube. To install the mirror cell into the optical tube, the rear end ring attached to the optical tube must first be removed. This



**Figure 3.** Place the three springs on the exposed threaded shafts of the mirror cell.

is done by unthreading and removing the six Phillips-head screws that connect the end ring to the tube (Figure 2), and then pulling the end ring off of the tube.

*Warning: Once the rear end ring is removed from the tube, the raw edge of the tube itself will be exposed. Be careful not to cut or otherwise hurt yourself on the tube's edge. Also be careful not to pinch yourself when attaching the assembled mirror cell onto the tube.*

Next, assemble the rear end ring to the mirror cell. Find a clean, flat surface, and turn the mirror cell over so that the mirror is facing downwards. Place the three springs onto the three exposed threaded shafts (Figure 3). Lower the end ring onto the mirror cell so the threaded shafts pass through it, and the end ring rests on the springs (Figure 4). Add a nylon washer to each collimation knob and thread the collimation knobs through the end ring and onto the threaded shafts (Figure 5). Make sure the knobs have at least three full turns



**Figure 4.** Lower the rear end ring onto the mirror cell so that the threaded shafts pass through the end ring, and the end ring rests on the springs.



**Figure 5.** Thread the collimation thumbnuts, with nylon washers attached, through the rear end ring and onto the threaded shafts. Make sure the thumbnuts have at least three full turns of engagement on the shafts.



**Figure 6.** Lower the assembled mirror cell onto the tube so one side of the end ring is seated on the tube edge. The threaded attachment holes in the end ring should also be lined up with the through holes in the end of the tube

of engagement on the shafts. The mirror cell is now ready to be installed into the tube.

Assembling the SkyQuest XT12 mirror cell to the tube can be a bit tricky. This is because the large diameter and thin steel of the tube will cause the tube to become somewhat out of round once the rear end ring is removed.

To assemble the mirror cell to the tube, stand the tube up vertically so that the raw edge of the tube is facing upwards. Line up the threaded holes in the edge of the mirror cell end ring with the holes in the end of the tube. Then, lower the mirror cell onto the tube so that one side of the end ring is fully seated onto the tube (Figure 6). Now, look along the perimeter of the tube, and you will notice a bulge in the tube that prevents the mirror cell from fully seating on the tube (Figure 7). Position your body so that your chest is pressing against this bulge, and hug the telescope with your left hand so that the tube becomes round. With your right hand, gently tap down the side of the mirror cell that needs to be seated, and the entire mirror cell should seat onto the tube (Figure 8).



**Figure 8.** Hug the tube so that your chest pushes against the bulge, and a gentle tap should fully seat the mirror cell onto the tube.

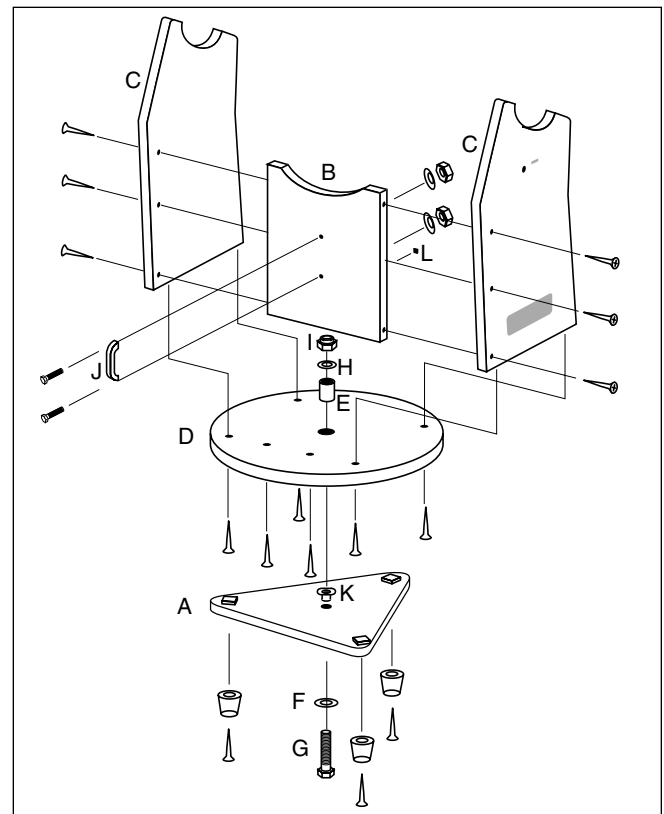

**Figure 7.** Locate the area of tube that is bulging out and preventing the mirror cell from fully seating.

Replace the six Phillips-head screws that connect the rear end ring to the tube.

### Assembly of the Dobsonian base

Refer to Figure 9 during base assembly. The base need only be assembled once, unless you disassemble it for long-term storage. The assembly process takes about 30 minutes and requires a Phillips screwdriver, an adjustable crescent wrench, and the provided hex keys.



**Figure 9.** Exploded view of the Dobsonian base.



**Figure 10.** Position the rubber bumper “stop” over the index mark on the inside surface of the front brace.

tighten them until firm, but be careful not to strip the holes by over-tightening. If you use an electric screwdriver, do final tightening with a standard screwdriver to avoid stripping.

1. Screw the plastic feet into the underside of the ground baseplate (A) using the self-tapping wood screws provided, with a Phillips screwdriver. Insert the screws through the feet and thread them into the predrilled starter holes.
2. Loosely attach the front brace (B) to the two side panels (C) with six of the base assembly screws in the predrilled holes. Use the 4mm hex key to tighten the screws. The side panels should be oriented so the SkyQuest labels are facing outward. The front brace should be oriented so the index mark is facing inwards. Do not completely tighten the screws yet.
3. Attach the two sides (C) with the front brace attached to the top baseplate (D) with the remaining six base assembly screws in the predrilled holes. Tighten all six screws.
4. Tighten the six side screws installed earlier.
5. Insert the white nylon bushing (E) into the hole in the center of the top baseplate (D). Tap the nylon bushing in so it goes all the way into the top baseplate. The nylon bushing should be flush with the top surface of the top baseplate.
6. Insert the T-nut (K) into the center hole of the ground baseplate (A) so the nut’s flanged top is on the same side of the baseplate as the Teflon pads. Thread the large hex-head screw (G) with a 3/8" washer (F) attached up through the ground baseplate and through the T-nut until it is tight. Now position the top baseplate (D) (with side panels attached) over the ground baseplate and lower it so the screw goes through the nylon spacer in the center hole of the top baseplate. Now thread the remaining 3/8" washer (H) and lock nut (I) onto the screw’s shaft. You might need to hold the screw’s head in place with another crescent wrench or pliers. Tighten the lock nut with a wrench just enough to allow a slight separation of the top and bottom baseplates when the mount is lifted. The purpose of the lock nut is merely to keep the two baseplates from coming apart when moving the telescope. Overtightening the lock nut (I) will make the mount difficult to rotate in the azimuthal (horizontal) direction.



**Figure 11.** Using the two supplied screws, install the aluminum eyepiece rack in the predrilled holes about halfway down the left side panel of the base.

7. Attach the handle (J) to the front brace (B) with the two black socket-head cap screws. Insert the screws through the handle and into the predrilled holes. Place the 5/16" washers and 5/16" nuts on the protruding ends of the screws. Tighten the nuts with a crescent wrench while holding the screws stationary with the 6mm hex key.
8. The rubber bumper (L) provides a convenient “stop” for the telescope’s altitude motion; it prevents the telescope mirror cell from being knocked against the hard surface of the base’s front brace. At the bottom of the interior surface of the front brace, you will notice a small index mark engraved. Remove the backing from the rubber bumper and position the bumper over the index mark, as shown in Figure 10. Press firmly so the adhesive holds the bumper securely in place.

### Installing the Eyepiece Rack

The aluminum eyepiece rack is a standard accessory on SkyQuest XT12 Dobsonians. It holds three 1.25" eyepieces and one 2" eyepiece in a convenient place on the base, within easy reach while you’re observing. A 1.25" barlow lens also can be held in the rack. About halfway down the left side



**Figure 12.** Set the optical tube on the “cradle” of the base so that the altitude side bearings on the tube rest on the white plastic “pads.”

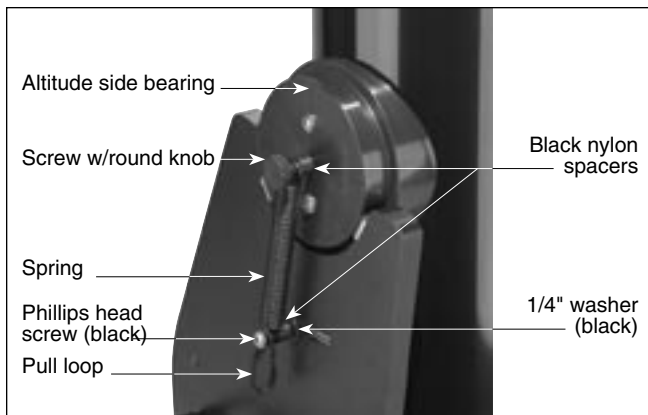

**Figure 13.** Close-up view of the CorrecTension system.

panel of the base you will notice two predrilled starter holes, about 6" apart. Take the black wood screws and thread them into the starter holes with a Phillips screwdriver. Then you can "keyhole" the eyepiece rack onto the wood screws and continue tightening the screws (Figure 11). If you want to be able to remove the rack, do not tighten the screws too tightly. Be certain the screws are loose enough so you can lift the rack and remove it from the screws through the larger part of the keyhole. If you want to have the rack permanently attached, thread the screws tightly.

### Placing the Optical Tube on the Dobsonian Base

Lift the optical tube and set the altitude bearings on either side of the tube in the "cradle" of the base (Figure 12). The unique flange design of the altitude bearing allows for automatic left-to-right centering of the optical tube in the cradle. Once in the cradle, the tube should pivot freely up and down with gentle hand pressure. Note that the tube will not yet be properly balanced, since the eyepiece and finder scope are not in place, and the CorrecTension system has not been installed.

### Installing the CorrecTension (XT) Friction Optimization System

Perhaps the most exciting new feature of the SkyQuest XT12 Dobsonian is the CorrecTension Friction Optimization system. Because of their relatively light weight, 12" and smaller Dobsonians have always been plagued by insufficient friction on the altitude bearing surfaces. As a result, such telescopes move up and down much too freely. This causes problems when the observer tries to accurately center and track an object for viewing, especially at higher powers. Also, the telescope becomes very sensitive to balance, requiring additional equipment such as counterweight systems or adjustable side bearings to compensate.

SkyQuest XT12 Dobsonians employ a simple yet effective remedy for the friction problem that obviates the need for such cumbersome countermeasures. CorrecTension Friction Optimization utilizes a spring coil to "pull" the tube assembly down onto the altitude bearing pads, thereby increasing the friction by just the right amount. With CorrecTension, you can change eyepieces or add a barlow lens without having to tediously adjust the telescope's balance as you would with

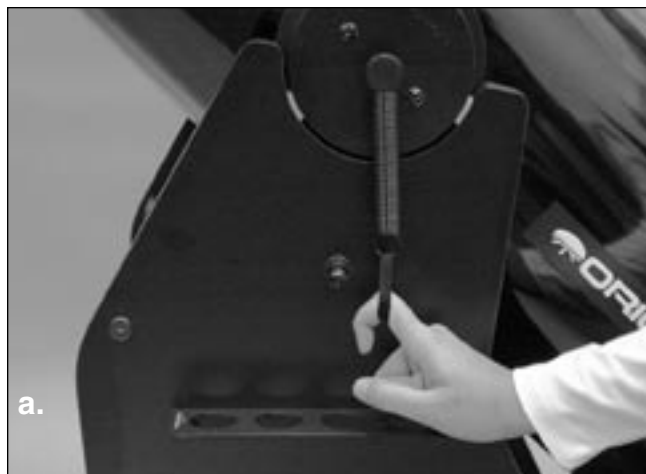
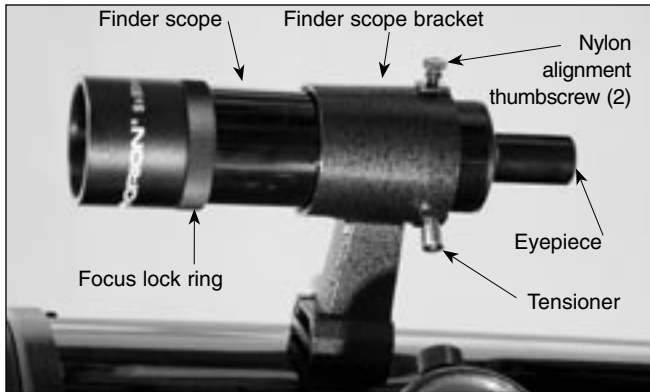

**Figure 14. (a)** To attach the spring to the base, grip the pull loop with your index finger and pull down on the spring. **(b)** While pulling down, slip the end ring of the spring over the screw head and onto the narrow part of the nylon spacer, then release the pull loop.

other Dobsonians. The altitude friction will roughly equal the azimuth friction, ensuring optimal performance.

To install the CorrecTension assembly, follow these steps while referring to Figure 13:

1. Put one of the black nylon spacers on a black Phillips head screw. The spacer should be oriented so the narrow end seats against the head of the screw. Slip one of the black 1/4" washers over the end of the screw. Now, thread the screw into the hole in the base side panel just below the cradle. The screw will thread into the preinstalled insert in the hole. Use a Phillips screwdriver to tighten the screw. Repeat this procedure on the opposite side panel.
2. Next, insert one of the screws with round plastic knob attached through the end ring of one of the springs. Slip a black nylon spacer onto the screw. Orient the spacer so the narrow end is closest to the knob. Thread the entire assembly into the hole in the center of the telescope's altitude side bearing until tight. The end ring of the spring



**Figure 15a.** The 9x50 finder scope and bracket.

should seat onto the narrow end of the spacer. Repeat this procedure for the other altitude side bearing.

3. Attach a pull loop to the free end of each spring. Slide the loop through the opening in the ring on the end of the spring.
4. Now, pull each spring down using the pull loop, and position the spring's end ring over the head of the Phillips screw (installed in step 1) and onto the narrow part of the nylon spacer, as shown in Figure 14. You needn't attach both springs simultaneously; one at a time is fine.

The CorrecTension system is now installed and engaged. If you wish to remove the telescope from the base, you will first need to disconnect the springs from the "posts" on the Dobsonian base. The springs will remain captive on the altitude side bearings, so they will not get lost.

### Installing the Finder Scope

SkyQuest XT12 Dobsonians come with a high quality, large aperture 9x50 achromatic crosshair finder scope (Figure 15a) as standard equipment. This greatly aids in finding objects to view in the night sky, which will be discussed in detail later.

To place the finder scope in the finder scope bracket, first unthread the two black nylon thumbscrews until the screw ends are flush with the inside diameter of the bracket. Place the O-ring that comes on the base of the bracket over the body of the finder scope until it seats into the slot on the middle of the finder scope. Slide the eyepiece end (narrow end) of the finder scope into the end of the bracket's cylinder opposite the alignment thumbscrews while pulling the chrome, spring-loaded tensioner on the bracket with your fingers (Figure 15b). Push the finder scope through the bracket until the O-ring seats just inside the front opening of the bracket cylinder. Now, release the tensioner and tighten the two black nylon thumbscrews a couple of turns each to secure the finder scope in place. Insert the base of the finder scope bracket into the dovetail holder located near the telescope's focuser. Lock the bracket into position by tightening the knurled thumb-screw on the dovetail holder.



**Figure 15b.** Pull back on the tensioner and slide the finder scope into its bracket until the O-ring is seated in the bracket ring.

### Inserting an Eyepiece

The final step in the assembly process is to insert an eyepiece into the telescope's focuser. Take the cover cap off the end of the focuser drawtube. Loosen the thumb screw on the 1.25" eyepiece adapter (see Figure 16). Do not loosen the two thumb screws on the 2" eyepiece adapter. Insert one of the supplied eyepieces, then secure it by retightening the thumb screw on the 1.25" eyepiece adapter. The other eyepiece can be placed in the eyepiece rack until it is needed.

The assembly of your SkyQuest Dobsonian is now complete. It should appear as shown in Figure 1. The dust cover on the front of the telescope tube should always remain in place when the telescope is not in use. It is also a good idea to store eyepieces in an eyepiece case and to replace the cover caps on the focuser and finder scope when the telescope is idle.

## 3. Using Your Telescope

It is best to get a feel for the basic functions of the SkyQuest XT12 Dobsonian during the day, before observing astronomical objects at night. This way you will not have to fumble around trying to orient yourself in the dark! Find a spot outdoors where you have plenty of room to move around the telescope, and where you have a clear view of some object or vista that is at least 1/4-mile away. It is not critical that the base be exactly

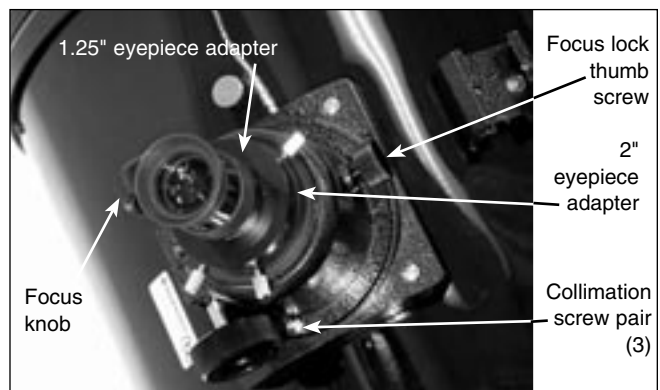

**Figure 16.** The large format focuser with eyepiece adapters attached. The focuser will accept eyepieces with barrel diameters of both 1.25" and 2".



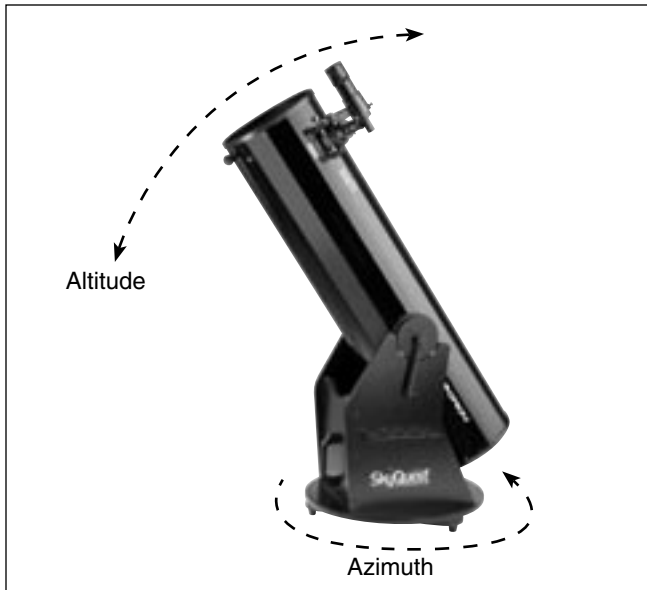

**Figure 17.** The SkyQuest has two axes of motion: altitude (up/down) and azimuth (left/right).

level, but it should be placed on somewhat flat ground or pavement to ensure smooth movement of the telescope.

Remember, never point the telescope at or near the Sun without using a proper solar filter over the front aperture!

### Altitude and Azimuth

The Dobsonian base of the SkyQuest XT12 permits motion of the telescope along two axes: altitude (up/down) and azimuth (left/right) (see Figure 17). This is very convenient, since up/down and left/right are the most “natural” ways that people aim. As a result, pointing the telescope is exceptionally easy.

Simply take hold of the navigation knob and move it left or right so the base rotates about its central azimuth bolt, and move it up or down so the altitude side bearings rotate in the base’s cradle. Both motions can be made simultaneously and in a continuous manner for easy aiming. Move the telescope gently — let it glide. In this way you can point the telescope to any position in the night sky, from horizon to horizon.

### Focusing the Telescope

With the 25mm eyepiece inserted in the focuser, move the telescope so the front (open) end is pointing in the general direction of an object at least 1/4-mile away. Now, with your fingers, slowly rotate one of the focusing knobs until the object comes into sharp focus. Go a little bit beyond sharp focus until the image just starts to blur again, then reverse the rotation of the knob, just to make sure you’ve hit the exact focus point.

If you have trouble focusing, rotate the focusing knob so the drawtube is in as far as it will go. Now look through the eyepiece while slowly rotating the focusing knob in the opposite direction. You should soon see the point at which focus is reached.



**Figure 18.** The view through a standard finder scope and a reflector telescope is upside down. This is true for the SkyQuest and its finder scope as well.

The thumb screw on the top of the body of the focuser (Figure 16) will lock the focuser drawtube into place once the telescope is properly focused. Before focusing, remember to first loosen this thumb screw.

If you find the drawtube tension when focusing is either too tight (focus knob is difficult to turn) or too loose (image shifts when focusing), you can adjust it by tightening or loosening the two drawtube tensioning set screws on the focuser. These are the two small set screws located on either side of the focus lock thumb screw. Adjusting these set screws requires a 1.5mm hex key.

### Viewing with Eyeglasses

If you wear eyeglasses, you may be able to keep them on while you observe. This requires your eyepieces to have enough eye relief to allow you to see the whole field of view. You can see if your eyepieces have enough eye relief by looking through the eyepiece first with your glasses on and then with them off, and see if the glasses restrict the view to only a portion of the full field. If they do, you can easily observe with your glasses off by just refocusing the telescope the needed amount. If you suffer from severe astigmatism, however, you may find images noticeably sharper with your glasses on.

### Aligning the Finder Scope

The finder scope must be aligned accurately with the telescope for proper use. To align it, first aim the main telescope in the general direction of an object at least 1/4-mile away — the top of a telephone pole, a chimney, etc. Position that object in the center of the telescope’s eyepiece.

Now look in the finder scope. Is the object visible? Ideally it will be somewhere in the field of view. If not, some coarse adjustment to the finder scope bracket’s alignment thumb-

screws will be needed until the object comes into the finder scope's field of view.

The SkyQuest XT12's finder scope uses a spring-loaded bracket that makes alignment of the finderscope very easy. As you turn either of the thumbscrews, the spring in the bracket's tensioner moves in and out to keep the finder scope secure in the bracket.

**Note: The image in both the finder scope and the main telescope will appear upside-down (rotated 180°). This is normal for finder scopes and reflector telescopes (see Figure 18).**

With the image in the finder scope's field of view, you now need to fine-adjust the alignment thumbscrews to center the object on the intersection of the crosshairs. Adjust the aim of the finder scope by turning the thumbscrews, one at a time, until the object is centered.

The finder scope alignment needs to be checked before every observing session. This can easily be done at night, before viewing through the telescope. Choose any bright star or planet, center the object in telescope eyepiece, and then adjust the finder scope bracket's alignment thumbscrews until the star or planet is centered on the finder's crosshairs.

### Focusing the Finder Scope

If, when looking through the finder scope, the images appear somewhat out of focus, you will need to refocus the finder scope for your eyes. Loosen the lock ring located behind the objective lens cell on the body of the finder scope (see Figure 15a). Back the lock ring off by a few turns, for now. Refocus the finder scope on a distant object by threading the objective lens cell in or out on the finder scope body. Precise focusing will be achieved by focusing the finder scope on a bright star. Once the image appears sharp, retighten the lock ring behind the objective lens cell. The finder scope's focus should not need to be adjusted again.

### Aiming/Pointing the Telescope

With the finder scope aligned, the telescope can be quickly and accurately pointed at anything you wish to observe. The finder scope has a much wider field of view than the telescope's eyepiece, and therefore it is much easier to first center an object in the finder scope. Then, if the finder scope is accurately aligned, the object will also be centered in the telescope's field of view.

Start by once again moving the telescope until it is pointed in the general direction of the object you want to see. Some observers find it convenient to sight along the tube to do this. Now, look in the finder scope. If your general aim is accurate, the object should appear somewhere in the field of view. Make small adjustments to the telescope's position until the object is centered on the finder's crosshairs. Now, look in the telescope's eyepiece and enjoy the view!

### Magnification

Once the object you want to view is well centered in the 25mm eyepiece, you may want to increase the magnification to get a closer view. Loosen the thumbscrew on the 1.25" eyepiece

adapter and remove the eyepiece. Place it in the eyepiece rack, if you wish. Insert the 10mm eyepiece into the 1.25" eyepiece adapter, then retighten the thumbscrew. If you were careful not to bump the telescope, the object should still be centered within the field of view. Notice that the object being viewed is now larger, but somewhat dimmer.

The SkyQuest XT12 is designed to accept any eyepiece with a barrel diameter of 1.25" or 2". Magnification, or power, is determined by the focal length of the telescope and the focal length of the eyepiece. Therefore, by using eyepieces of different focal lengths, the resultant magnification can be varied.

Magnification is calculated as follows:

$$\frac{\text{Telescope Focal Length (mm)}}{\text{Eyepiece Focal Length (mm)}} = \text{Magnification}$$

The SkyQuest XT12 Dobsonian has a focal length of 1500mm. So, the magnification with the supplied 25mm eyepiece is

$$\frac{1500\text{mm}}{25\text{mm}} = 60\text{x}$$

The magnification provided by the 10mm eyepiece is

$$\frac{1500\text{mm}}{10\text{mm}} = 150\text{x}$$

The maximum attainable magnification for a telescope is directly related to how much light its optics can collect. A telescope with more light collecting area, or aperture, can yield higher magnifications than a smaller aperture telescope. The maximum practical magnification for any telescope, regardless of optical design, is about 60x per inch of aperture. This translates to about 720x for the SkyQuest XT12.

Keep in mind that as magnification is increased, the brightness of the object being viewed will decrease; this is an inherent principle of the physics of optics and cannot be avoided. If magnification is doubled, an image appears four times dimmer. If magnification is tripled, image brightness is reduced by a factor of nine!

### Note About High Magnifications:

Maximum magnifications are achieved only under the most ideal viewing conditions at the best observing sites. Most of the time, magnifications are limited to 200x or less, regardless of aperture. This is because the Earth's atmosphere distorts light as it passes through. On nights of good "seeing", the atmosphere will be still and will yield the least amount of distortion. On nights of poor seeing, the atmosphere will be turbulent, which means different densities of air are rapidly mixing. This causes significant distortion of the incoming light, which prevents sharp views at high magnifications.

### Tube Balance

Dobsonians are designed to balance with standard supplied accessories, such as an eyepiece and a finder scope. But what if you want to use other accessories such as a barlow lens or a heavy 2" eyepiece? Traditional Dobsonian designs

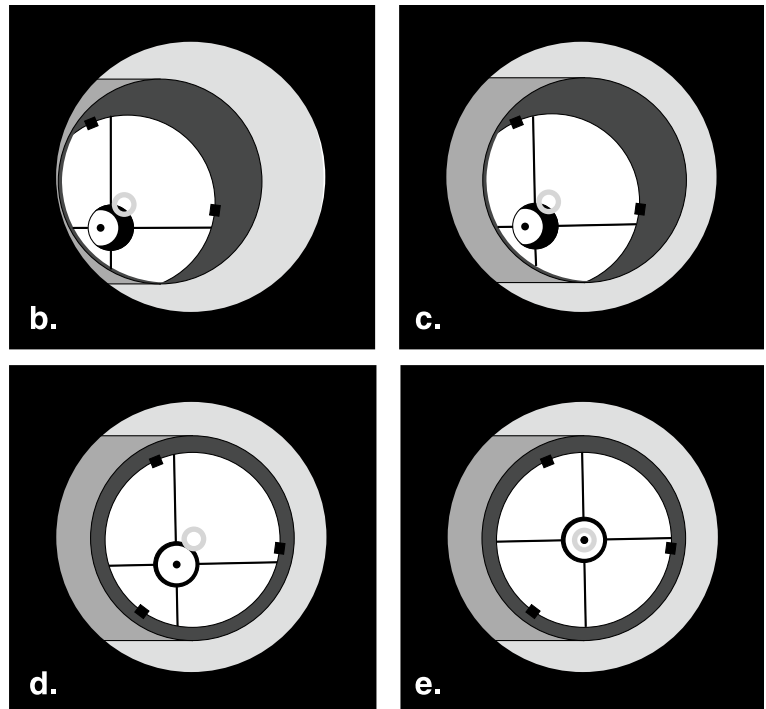
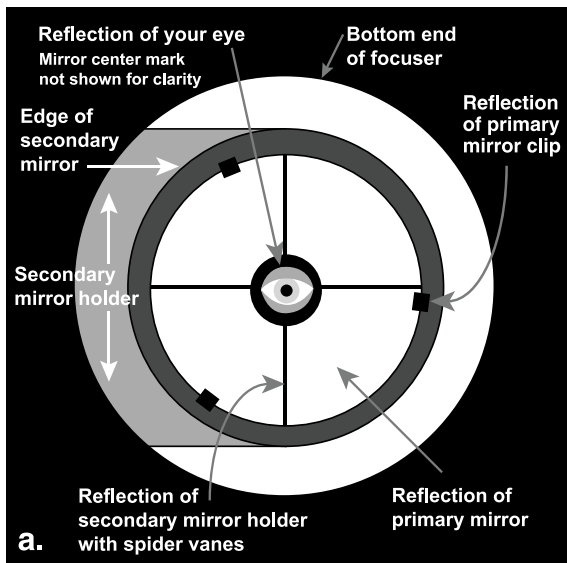

**Figure 19.** Collimating the optics. **(a)** When the mirrors are properly aligned, the view down the focuser drawtube should look like this. **(b)** With the collimation cap in place, if the optics are out of alignment, the view might look something like this. **(c)** Here, the secondary mirror is centered under the focuser, but it needs to be adjusted (tilted) so that the entire primary mirror is visible. **(d)** The secondary mirror is correctly

aligned, but the primary mirror still needs adjustment. When the primary mirror is correctly aligned, the “dot” will be centered, as in **(e)**.

expect the user to compensate for heavier accessories by adding weight to the opposite end of the telescope tube. Such counterweighting systems can be expensive and unwieldy.

The CorrecTension Friction Optimization system of the SkyQuest XT12 Dobsonian, however, solves the finicky balance problem. The spring coils pull the tube down onto the base, thereby increasing the friction on the altitude bearing pads. With CorrecTension, the added weight of small front-end loads will not adversely affect the balance of the telescope.

If you install an array of heavier accessories onto your SkyQuest XT12’s optical tube, you may need at some point to counterbalance the telescope with a counterweight system.

### Transporting the Telescope

Even though it is a larger-aperture instrument, transporting the SkyQuest XT12 is relatively easy. Remove any eyepieces from the telescope and eyepiece rack, and place them in an eyepiece case. You can also remove the finder scope and finder scope bracket, if you wish. Disengage the CorrecTension springs by unhooking them from the posts on the base, using the pull loops. The springs remain captive on the telescope side bearings. The base and tube are now disengaged and can be transported separately.

The tube is somewhat heavy, so don’t hesitate to have a friend help lift the tube, if necessary. Do not use the navigation knob as a carry handle! It is not designed to support the weight of the telescope tube and could break off or damage the tube. To carry the base, simply grasp the handle on the front of it.

When putting the SkyQuest XT12 into a vehicle, common sense prevails. It is especially important that the optical tube does not knock around; this can cause the optics to become misaligned, and could dent the tube. We recommend transporting and storing the tube assembly in a padded case for proper protection.

## 4. Collimation (Aligning The Mirrors)

Collimation is the process of adjusting the mirrors so they are properly aligned with one another. Your telescope’s optics were aligned at the factory, and should not need much adjustment unless the telescope is handled roughly. Accurate mirror alignment is important to ensure the peak performance of your telescope, so it should be checked regularly. Collimation is relatively easy to do and can be done in daylight.

To check collimation, remove the eyepiece and look down the focuser drawtube. You should see the secondary mirror centered in the drawtube, as well as the reflection of the primary mirror centered in the secondary mirror, and the reflection of the secondary mirror (and your eye) centered in the reflection of the primary mirror, as in Figure 19a. If anything is off-center, as in Figure 19b, proceed with the following collimation procedure.

### The Collimation Cap and Mirror Center Mark

Your SkyQuest XT12 comes with a collimation cap. This is a simple cap that fits on the focuser drawtube like a dust cap, but



**Figure 20.** To center the secondary mirror under the focuser, hold the secondary mirror holder in place with your fingers while adjusting the center screw with a Phillips screwdriver. Do not touch the mirror's surface!

has a hole in the center and a silver bottom. This helps center your eye so that collimation is easy to perform. Figures 19b through 19e assume you have the collimation cap in place.

In addition to the collimation cap, the primary mirror is marked with a circle at its exact center. This “center mark” allows you to achieve a precise collimation of the primary mirror; you don’t have to guess where the center of the mirror is. You simply adjust the mirror position (described below) until the reflection of the hole in the collimation cap is centered in the ring. The center mark is also required for best results when using other collimating devices, such as Orion’s LaserMate Laser Collimator, obviating the need to remove the primary mirror and mark it yourself.

**Note: The center ring sticker need not ever be removed from the primary mirror. Because it lies directly in the shadow of the secondary mirror, its presence in no way adversely affects the optical performance of the telescope or the image quality. That might seem counter-intuitive, but it's true!**

### Aligning the Secondary Mirror

With the collimation cap in place, look through the hole in the cap at the secondary (diagonal) mirror. Ignore the reflections for the time being. The secondary mirror itself should be centered in the focuser drawtube, in the direction parallel to the length of the telescope. If it isn’t, as in Figure 19b, it must be adjusted. This adjustment will rarely, if ever need to be done. It helps to adjust the secondary mirror in a brightly lit room with the telescope pointed towards a bright surface, such as white paper or wall. Also placing a piece of white paper in the telescope tube opposite the focuser (in other words, on the other side of the secondary mirror) will also be helpful in collimating the secondary mirror. Using a 2mm hex key, loosen the three small alignment set screws in the center hub of the 4-vaned spider several turns. Now hold the mirror holder stationary (be careful not to touch the surface of the mirrors), while turning the center screw with a Phillips head screwdriver (See Figure 20). Turning the screw clockwise will move the secondary mirror toward the front opening of the optical



**Figure 21.** Adjust the tilt of the secondary mirror by loosening or tightening the three alignment screws with a 2mm hex key.

tube, while turning the screw counter-clockwise will move the secondary mirror toward the primary mirror.

**Note: When making these adjustments, be careful not to stress the spider vanes or they may bend.**

When the secondary mirror is centered in the focuser drawtube, rotate the secondary mirror holder until the reflection of the primary mirror is as centered in the secondary mirror as possible. It may not be perfectly centered, but that is OK. Now tighten the three small alignment screws equally to secure the secondary mirror in that position.

If the entire primary mirror reflection is not visible in the secondary mirror, as in Figure 19c; you will need to adjust the tilt of the secondary mirror. This is done by alternately loosening one of the three alignment set screws while tightening the other two, as depicted in Figure 21. The goal is to center the primary mirror reflection in the secondary mirror, as in Figure 19d. Don’t worry that the reflection of the secondary mirror (the smallest circle, with the collimation cap “dot” in the center) is off-center; you will fix that in the next step.

### Adjusting the Primary Mirror

The final adjustment is made to the primary mirror. It will need adjustment if, as in Figure 19d, the secondary mirror is centered under the focuser and the reflection of the primary mirror is centered in the secondary mirror, but the small reflection of the secondary mirror (with the “dot” of the collimation cap) is off-center.

The tilt of the primary mirror is adjusted with three spring-loaded collimation thumbscrews on the back end of the optical tube (bottom of the primary mirror cell); these are the larger thumbscrews. The other three smaller thumbscrews lock the mirror’s position in place; these thumbscrews must be loosened before any collimation adjustments can be made to the primary mirror.

To start, turn the smaller thumbscrews that lock the primary mirror in place a few turns each (Figure 22). Use a screwdriver in the slots, if necessary.



**Figure 22.** The three thumb screws that lock the primary mirror in place must first be loosened before any adjustments can be made.

Now, try tightening or loosening one of the larger collimation thumbscrews with your fingers (Figure 23). Look into the focuser and see if the secondary mirror reflection has moved closer to the center of the primary. You can tell this easily with the collimation cap and mirror center mark by simply watching to see if the “dot” of the collimation cap is moving closer or further away from the “ring” on the center of the primary mirror mark. When you have the dot centered as much as is possible in the ring, your primary mirror is collimated. The view through the collimation cap should resemble Figure 19e. Re-tighten the locking thumbscrews.

A simple star test will tell you whether the optics are accurately collimated.

#### **Note About the Collimatable 2" Focuser**

The 2" focuser of the SkyQuest XT12 can be collimated using three pairs of push-pull screws located at the base of the focuser. The focuser was collimated at the factory however, and should not need to be adjusted. Focuser collimation is only required under very rare circumstances, but has been made available for this telescope should such a need arise.

#### **Star-Testing the Telescope**

When it is dark, point the telescope at a bright star and accurately center it in the eyepiece’s field-of-view. Slowly defocus the image with the focusing knob. If the telescope is correctly collimated, the expanding disk should be a perfect circle (Figure 24). If the image is unsymmetrical, the scope is out of collimation. The dark shadow cast by the secondary mirror should appear in the very center of the out-of-focus circle, like the hole in a doughnut. If the “hole” appears off-center, the telescope is out of collimation.

If you try the star test and the bright star you have selected is not accurately centered in the eyepiece, then the optics will always appear out of collimation, even though they may be perfectly aligned. It is critical to keep the star centered, so over time you will need to make slight corrections to the telescope’s position in order to account for the sky’s apparent motion.



**Figure 23.** The tilt of the primary mirror is adjusted by turning one or more of the three spring-loaded collimation thumb screws.

## **5. Astronomical Observing**

For many users, the SkyQuest XT12 telescope will be a major leap into the world of amateur astronomy. This section is intended to get you ready for your voyages through the night sky.

#### **Site Selection**

Pick a location away from street lights and bright yard lighting. Avoid viewing over rooftops and chimneys, as they often have warm air currents rising from them, which distort the image seen in the eyepiece. Similarly, you should not observe through an open window from indoors. Better yet, choose a site out-of-town, away from any “light pollution”. You’ll be stunned at how many more stars you’ll see! Most importantly, make sure that any chosen site has a clear view of a large portion of the sky.

#### **Seeing and Transparency**

Atmospheric conditions play a huge part in quality of viewing. In conditions of good “seeing”, star twinkling is minimal and objects appear steady in the eyepiece. Seeing is best overhead, worst at the horizon. Also, seeing generally gets better after midnight, when much of the heat absorbed by the Earth during the day has radiated off into space. Typically, seeing conditions will be better at sites that have an altitude over about

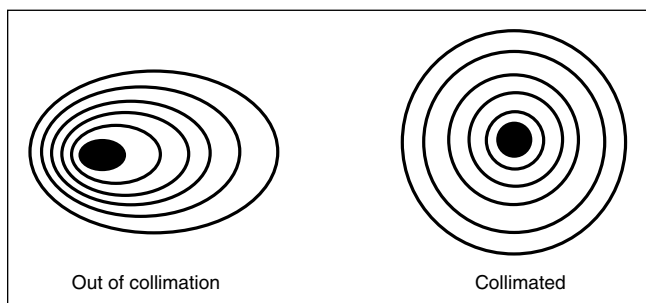

**Figure 24.** A star test will determine if a telescope’s optics are properly collimated. An unfocused view of a bright star through the eyepiece should appear as illustrated on right if optics are perfectly collimated. If circle is unsymmetrical, as in illustration on left, scope needs collimation.

---

3000 feet. Altitude helps because it decreases the amount of distortion causing atmosphere you are looking through.

A good way to judge if the seeing is good or not is to look at bright stars about 40° above the horizon. If the stars appear to “twinkle”, the atmosphere is significantly distorting the incoming light, and views at high magnifications will not appear sharp. If the stars appear steady and do not twinkle, seeing conditions are probably good, and higher magnifications will be possible.

Also, seeing conditions are typically poor during the day. This is because the heat from the Sun warms the air and causes turbulence.

Good “transparency” is especially important for observing faint objects. It simply means the air is free of moisture, smoke, and dust. All tend to scatter light, which reduces an object’s brightness.

### **Cooling the Telescope**

All optical instruments need time to reach “thermal equilibrium” to achieve maximum stability of the lenses and mirrors, which is essential for peak performance. When moved from a warm indoor location outside to cooler air (or vice-versa), a telescope needs time to cool to the outdoor temperature. The bigger the instrument and the larger the temperature change, the more time will be needed.

Allow at least 30 minutes for your SkyQuest XT12 to equilibrate. If the scope has more than a 40° temperature adjustment, allow an hour or more. In the winter, storing the telescope outdoors in a shed or garage greatly reduces the amount of time needed for the optics to stabilize. It also is a good idea to keep the scope covered until the Sun sets so the tube does not heat greatly above the temperature of the outside air.

The SkyQuest XT12 has the ability to mount a small fan to make cooling the tube faster. On the bottom of the mirror cell there are four threaded holes (M4-.7) where a fan can be attached. Orion sells a cooling fan for the SkyQuest XT12; consult the Orion catalog or OrionTelescopes.com for details.

### **Let Your Eyes Dark-Adapt**

Do not expect to go from a lighted house into the darkness of the outdoors at night and immediately see faint nebulas, galaxies, and star clusters — or even very many stars, for that matter. Your eyes take about 30 minutes to reach perhaps 80% of their full dark-adapted sensitivity. Many observers notice improvements after several hours of total darkness. As your eyes become dark-adapted, more stars will glimmer into view and you will be able to see fainter details in objects you view in your telescope. Exposing your eyes to very bright daylight for extended periods of time can adversely affect your night vision for days. So give yourself at least a little while to get used to the dark before you begin observing.

To see what you are doing in the darkness, use a red-filtered flashlight rather than a white light. Red light does not spoil your eyes’ dark adaptation like white light does. A flashlight with a red LED light is ideal, or you can cover the front of a regular incandescent flashlight with red cellophane or paper.

Beware, too, that nearby porch and streetlights and automobile headlights will spoil your night vision.

### **Tracking Celestial Objects**

The Earth is constantly rotating about its polar axis, completing one full rotation every 24 hours; this is what defines a “day”. We do not feel the Earth rotating, but we can tell that it is at night by seeing the apparent movement of stars from east to west. This movement translates into a rate of approximately .25° per minute, or 15 arc-seconds per second. (There are 60 arc-minutes in 1°, and 60 arc-seconds in one arc-minute.) This is called the sidereal rate.

When you observe any astronomical object, you are watching a moving target. This means the telescope’s position must be slowly updated over time to keep an object in the field of view. To keep the object in the telescope’s field of view (to “track” it), the telescope must be moved by small increments every now and then, in the direction the object is moving. This is easy to do with a SkyQuest XT12 Dobsonian because of its buttery smooth motion on both axes. As the object moves off toward the edge of the field of view, you just lightly nudge the telescope to bring it back to the center.

You will notice that it is more difficult to track objects when the telescope tube is aimed nearly straight up. This is inherent to the basic design of the Dobsonian, and stems from the fact that there is very little leverage to move in azimuth when the tube is in a near-vertical position. To gain more leverage, try grasping the tube close to the altitude side bearings with both hands. Also, when looking overhead, if the telescope cannot be moved any more in altitude, rotate the telescope 180° in azimuth to continue motion.

Remember that objects appear to move across the field of view faster at higher magnifications. This is because the field of view becomes narrower.

### **Eyepiece Selection**

By using eyepieces of varying focal lengths, it is possible to attain many magnifications with the SkyQuest XT12 Dobsonian. The telescopes come with two high-quality Sirius Plössl eyepieces: a 25mm, which gives a magnification of 60x, and a 10mm, which gives a magnification of 150x. Other eyepieces can be used to achieve higher or lower powers. It is quite common for an observer to own five or more eyepieces to access a wide range of magnifications. This allows the observer to choose the best eyepiece to use depending on the object being viewed. At least to begin with, the two supplied eyepieces will suffice nicely.

Whatever you choose to view, always start by inserting your lowest power (longest focal length) eyepiece to locate and center the object. Low magnification yields a wide field of view, which shows a larger area of sky in the eyepiece. This makes acquiring and centering an object much easier. If you try to find and center objects with high power (narrow field of view), it’s like trying to find a needle in a haystack!

Once you’ve centered the object in the eyepiece, you can switch to higher magnification (shorter focal length eyepiece), if you wish. This is especially recommended for small and

---

bright objects, like planets and double stars. The Moon also takes higher magnifications well.

Deep-sky objects, however, typically look better at medium or low magnifications. This is because many of them are quite faint, yet have some extent (apparent width). Deep-sky objects will often disappear at higher magnifications, since greater magnification inherently yields dimmer images. This is not the case for all deep-sky objects, however. Many galaxies are quite small, yet are somewhat bright, so higher power may show more detail.

The best rule of thumb with eyepiece selection is to start with a low power, wide field, and then work your way up in magnification. If the object looks better, try an even higher magnification. If the object looks worse, then back off the magnification a little by using a lower power eyepiece.

### Use of 2" Eyepieces

The SkyQuest XT12 comes with a large format focuser (Figure 16) as standard equipment. Because of its large size, it is able to accept eyepieces that have a 2" barrel diameter. 2" eyepieces are desirable because they allow for a wider field of view than 1.25" eyepieces. Many observers own at least one 2" eyepiece to yield the largest field of view possible for looking at wide deep sky objects, such as open star clusters and gaseous nebulae. 2" eyepieces can also give nice views of the Moon.

To use a 2" eyepiece, simply remove the 1.25" eyepiece adapter from the end of the focuser drawtube. You must first loosen the two thumb screws on the 2" eyepiece adapter to do this. Now, insert a 2" eyepiece into the focuser, and secure it with the two thumb screws. Focus the eyepiece as described previously.

You'll be stunned at the wide fields of view that 2" eyepieces can deliver. It will make you feel like you're floating through space!

### Astronomical Objects

Now that you are all set up and ready to go, one critical decision must be made: what to look at?

#### A. The Moon

With its rocky and cratered surface, the Moon is one of the most interesting and easy subjects to view with your scope. The best time to view it is during its partial phases when shadows fall on the craters and canyon walls to give them definition. While the full moon may look like a tempting target, it is not optimal for viewing! The light is too bright and surface definition is low.

Even at partial phases the Moon is very bright. Use of an optional Moon filter to help to dim the glare. It simply threads onto the bottom of the eyepiece. You'll find the Moon filter improves viewing comfort, and helps bring out the subtle features of the lunar surface.

#### B. The Sun

You can change your nighttime telescope into a daytime Sun viewer by installing an optional full-aperture solar filter over

the front opening of the telescope. The primary attraction is sunspots, which change shape, appearance, and location daily. Sunspots are directly related to magnetic activity in the Sun. Many observers like to make drawings of sunspots to monitor how the Sun is changing from day to day.

**Important Note: Do not look at the Sun with any optical instrument without a professionally made solar filter, or permanent eye damage could result. Also, be sure to cover the finder scope, or better yet, remove it altogether.**

#### C. The Planets

The planets don't stay put like the stars, so to find them you should refer to Sky Calendar at our website OrionTelescopes.com, or to charts published monthly in *Astronomy*, *Sky & Telescope*, or other astronomy magazines. Venus, Mars, Jupiter, and Saturn are the brightest objects in the sky after the Sun and the Moon. Your SkyQuest XT12 is capable of showing you these planets in some detail. Other planets may be visible but will likely appear starlike. Because planets are quite small in apparent size, optional higher power eyepieces are recommended and often needed for detailed observations. Not all the planets are generally visible at any one time.

**JUPITER** The largest planet, Jupiter, is a great subject for observation. You can see the disk of the giant planet and watch the ever-changing positions of its four largest moon: Io, Callisto, Europa, and Ganymede. Higher power eyepieces should bring out the cloud bands on the planet's disk and the Great Red Spot.

**SATURN** The ringed planet is a breathtaking sight. The tilt angle of the rings varies over a period of many years; sometimes they are seen edge-on, while at other times they are broadside and look like giant "ears" on each side of Saturn's disk. A steady atmosphere (good seeing) is necessary for a good view. Look closely and you should see the Cassini division, a thin, dark gap in the rings. You should also see one or more of Saturn's moons, which look like faint stars. The brightest is the moon Titan.

**VENUS** At its brightest, Venus is the most luminous object in the sky, excluding the Sun and the Moon. It is so bright that sometimes it is visible to the naked eye during full daylight! Ironically, Venus appears as a thin crescent, not a full disk, when at its peak brightness. Because it is so close to the Sun, it never wanders too far from the morning or evening horizon. No surface markings can be seen on Venus, which is always shrouded in dense clouds.

**MARS** The Red Planet makes a close approach to Earth every two years. Observing Mars is most favorable at these times. You should see salmon-colored disk with some distinct dark patches, and you may be able to spot a whitish polar ice cap. To see surface detail on Mars, you will need a high power eyepiece and very steady air!

#### D. The Stars

Stars will appear as tiny points of light. Even powerful telescopes cannot magnify stars to appear as anything more than pinpoints. You can, however, enjoy the different colors

of the stars and locate many pretty double and multiple stars. The famous “Double-Double” in the constellation Lyra and the gorgeous two-color double star Albireo in Cygnus are favorites. Defocusing a star slightly can help bring out its color.

### E. Deep-Sky Objects

Under dark skies, you can observe a wealth of fascinating deep-sky objects; that is, objects that reside outside of our solar system. These include gaseous nebulas, open and globular star clusters, and a variety of different types of galaxies. The large apertures of SkyQuest XT12 Dobsonians are particularly well suited to gathering light, which is critical for observing these usually faint celestial entities. For deep-sky observing it is important that you find an observing site well away from light pollution. Take plenty of time to let your eyes adjust to the darkness. As you become more experienced and your observing skills get sharper, you will be able to ferret out more and more subtle details and structure from these fascinating objects. Do not expect to see color in deep-sky objects, however, as human eyes are not sensitive to color from faint light.

#### How to Find Deep-sky Objects: Starhopping

Starhopping, as it is called by astronomers, is perhaps the simplest way to hunt down objects to view in the night sky. It entails first pointing the telescope at a star close to the object you wish to observe, and then progressing to other stars closer and closer to the object until it is in the field of view of the eyepiece. It is a very intuitive technique that has been employed for hundreds of years by professional and amateur astronomers alike. Keep in mind, as with any new task, that starhopping may seem challenging at first, but will become easier over time and with practice.

To starhop, only a minimal amount of additional equipment is necessary. A star chart or atlas that shows stars to at least magnitude 5 is required. Select one that shows the positions of many deep-sky objects, so you will have a lot of options to choose from. If you do not know the positions of the constellations in the night sky, you will need to get a planisphere to identify them.

Start by choosing bright objects to view. The brightness of an object is measured by its visual magnitude; the brighter an object, the lower its magnitude. Choose an object with a visual magnitude of 9 or lower. Many beginners start with the Messier objects, which represent some of the best and brightest deep-sky objects, first catalogued about 200 years ago by the French astronomer Charles Messier.

Determine in which constellation the object lies. Now, find the constellation in the sky. If you do not recognize the constellations on sight, consult a planisphere. The planisphere gives an all-sky view and shows which constellations are visible on a given night at a given time.

Now, look at your star chart and find the brightest star in the constellation that is near the object you are trying to find. Using the finder scope, point the telescope at this star and center it on the crosshairs. Next, look again at the star chart and find another suitably bright star near the bright star currently centered in the finder. Keep in mind that the field of

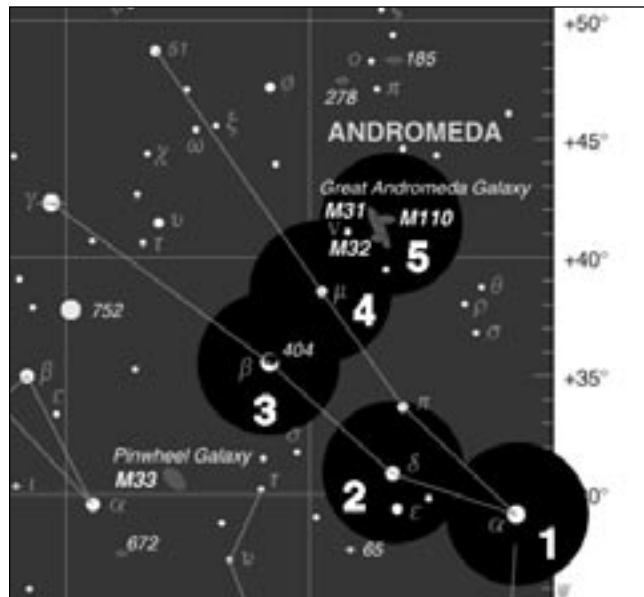

**Figure 25.** Starhopping is a good way to locate hard-to-find objects. Refer to a star chart to map a route to the object that uses bright stars as guideposts. Center the first star you’ve chosen in the finder scope and telescope eyepiece (1). Now move the scope carefully in the direction of the next bright star (2), until it is centered. Repeat (3 and 4). The last hop (5) should place the desired object in the eyepiece.

view of the finder scope is approximately  $5^\circ$ , so you should choose another star that is no more than  $5^\circ$  from the first star, if possible. Move the telescope slightly, until the telescope is centered on the new star.

Continue using stars as guideposts in this way until you are at the approximate position of the object you are trying to find (Figure 25). Look in the telescope’s eyepiece, and the object should be somewhere within the field of view. If it’s not, sweep the telescope carefully around the immediate vicinity until the object is found.

If you have trouble finding the object, start the starhop again from the brightest star near the object you wish to view. This time, be sure the stars indicated on the star chart are in fact the stars you are centering in the eyepiece. Remember, the finder scope (and main telescope eyepiece, for that matter) gives an inverted image, so you must keep this in mind when starhopping from star to star.

#### Note About Astrophotography

SkyQuest XT12 Dobsonians are designed for visual, not photographic use. The Dobsonian mount is not an equatorial-type mount, so it cannot be motor driven for long exposure astrophotography. SkyQuests have also been optically optimized for visual use, since photographic optimization degrades visual performance.

With that in mind, however, it is possible to do some simple astrophotography with a SkyQuest. With the use of afocal photography techniques (where the camera is simply placed to the eyepiece to take a picture) and digital cameras, it is



---

possible to take pictures of bright objects. Certain photographic aids, such as the Orion SteadyPix, can help in taking photos by the afocal method.

## 6. Care and Maintenance

If you give your telescope reasonable care, it will last a lifetime. Store it in a clean, dry, dust-free place, safe from rapid changes in temperature and humidity. Do not store the telescope outdoors, although storage in a garage or shed is OK. Small components like eyepieces and other accessories should be kept in a protective box or storage case. Keep the cap on the front of the telescope when it is not in use.

The telescope requires very little mechanical maintenance. The optical tube is steel and has a smooth painted finish that is fairly scratch-resistant. If a scratch does appear on the tube, it will not harm the telescope. Smudges on the tube can be wiped off with a soft cloth and a household cleaning fluid.

### Cleaning Lenses

Any quality optical lens cleaning tissue and optical lens cleaning fluid specifically designed for multi-coated optics can be used to clean the exposed lenses of your eyepieces or finder scope. Never use regular glass cleaner or cleaning fluid designed for eyeglasses. Before cleaning with fluid and tissue, however, blow any loose particles off the lens with a blower bulb or compressed air. Then apply some cleaning fluid to a tissue, never directly on the optics. Wipe the lens gently in a circular motion, then remove any excess fluid with a fresh lens tissue. Oily fingerprints and smudges may be removed using this method. Use caution; rubbing too hard may scratch the lens. On larger lenses, clean only a small area at a time, using a fresh lens tissue on each area. Never reuse tissues.

### Cleaning Mirrors

You should not have to clean the telescope's mirrors very often; normally once every few years or so. Covering the telescope with the dust cover when it is not in use will prevent dust from accumulating on the mirrors. Improper cleaning can scratch mirror coatings, so the fewer times you have to clean the mirrors, the better. Small specks of dust or flecks of paint have virtually no adverse effect on the visual performance of the telescope.

The large primary mirror and the elliptical secondary mirror of your telescope are front-surface aluminized and over-coated with hard silicon dioxide, which prevents the aluminum from oxidizing. These coatings normally last through many years of use before requiring re-coating (which is easily done).

To clean the secondary mirror, you will need to remove it from the telescope. Before doing so, orient the telescope tube horizontally so that nothing accidentally falls down and hits the primary mirror. Hold the secondary mirror holder stationary while loosening and removing the center Phillips-head screw. Handle the mirror by its holder; do not touch the mirror surface itself. Once the mirror (still in its holder) is removed from the tube, follow the same procedure described below for cleaning

the primary mirror. You do not need to remove the secondary mirror from its holder when cleaning.

To clean the primary mirror, you must carefully remove the mirror cell from the telescope. To do this, remove the six screws on the side of the tube near the primary mirror cell. You do not need to remove the collimation screws on the bottom of the mirror cell. Remove the mirror cell from the tube. You will notice the primary mirror is held down with three clips fastened by two screws each. Loosen the screws and remove the clips.

You may now remove the mirror from the mirror cell. Do not touch the surface of the mirror with your fingers; lift it carefully by the edge. Set the mirror, aluminized face up, on a clean, soft towel. Fill a clean sink free of abrasive cleanser with room-temperature water, a few drops of liquid dishwashing detergent, and if possible a capful of 100% isopropyl alcohol. Submerge the mirror (aluminized face up) in the water and let it soak for a few minutes (or hours if it's a very dirty mirror). Wipe the mirror under water with clean cotton balls, using extremely light pressure and stroking in a straight line across the mirror. Use one ball for each wipe across the mirror. Then rinse the mirror under a stream of lukewarm water. Any particles on the surface can be swabbed gently with a series of cotton balls, each used just one time. Dry the mirror in a stream of air (a "blower bulb" works great), or remove any stray drops of water with the corner of a paper towel. Water will run off a clean surface. Cover the mirror surface with a tissue, and leave the mirror in a warm area until it is completely dry before reassembling the telescope.

## 7. Specifications

Primary mirror: 305mm diameter, 1500mm focal length, BK7 optical glass

Focal ratio: f/4.9

Finder scope: Rack-and-pinion. accepts 2" and 1.25" eyepieces with included adapter, collimatible

Optical tube material: Rolled steel

Eyepieces: 25mm & 10mm Sirius Plössls, multi-coated, 1.25" barrel diameter

Eyepiece magnifications: 60x (25mm) and 150x (10mm)

Finder scope: 9x power, 50mm aperture, achromat, cross-hair, 5° field of view

Finder scope bracket: Dovetail base, spring-loaded X-Y alignment

Eyepiece rack: Holds three 1.25" eyepieces and one 2" eyepiece

Mirror coatings: Aluminum with SiO<sub>2</sub> overcoat

Minor axis of secondary mirror: 70mm

Optical tube weight: 50 lbs.

Base weight: 33 lbs.

Tube length: 58"

Tube outer diameter: 14"





---

## **One-Year Limited Warranty**

This Orion SkyQuest XT12 Classic Dobsonian Reflecting Telescope is warranted against defects in materials or workmanship for a period of one year from the date of purchase. This warranty is for the benefit of the original retail purchaser only. During this warranty period Orion Telescopes & Binoculars will repair or replace, at Orion's option, any warranted instrument that proves to be defective, provided it is returned postage paid to: Orion Warranty Repair, 89 Hangar Way, Watsonville, CA 95076. If the product is not registered, proof of purchase (such as a copy of the original invoice) is required.

This warranty does not apply if, in Orion's judgment, the instrument has been abused, mishandled, or modified, nor does it apply to normal wear and tear. This warranty gives you specific legal rights, and you may also have other rights, which vary from state to state. For further warranty service information, contact: Customer Service Department, Orion Telescopes & Binoculars, P. O. Box 1815, Santa Cruz, CA 95061; (800) 676-1343.

### **Orion Telescopes & Binoculars**

**Post Office Box 1815, Santa Cruz, CA 95061**

**Customer Support Help Line (800) 676-1343 • Day or Evening**