

# Orion® Ritchey-Chrétien Astrographs

#8956 6" f/9 Ritchey-Chrétien Optical Tube Assembly

#8958 8" f/8 Ritchey-Chrétien Optical Tube Assembly



 **ORION**  
TELESCOPES & BINOCULARS  
*Providing Exceptional Consumer Optical Products Since 1975*

[OrionTelescopes.com](http://OrionTelescopes.com)

**Customer Support (800) 676-1343 • E-mail: [support@telescope.com](mailto:support@telescope.com)**

Corporate Offices (831) 763-7000 • 89 Hangar Way, Watsonville, CA 95076



**Figure 1:** The Ritchey-Chrétien Optical Tube (6" shown)

*Congratulations on your purchase of an Orion Ritchey-Chrétien astrograph!* Astroimaging demands high contrast and center to edge image sharpness. The Ritchey-Chrétien optical system features precision hyperbolic mirrors with an impressive reflectivity rating of no less than 94%. These highly corrected optics offer virtually coma-free performance; and multiple knife-edge baffles provide images with superb contrast. These design features will offer a lifetime of outstanding performance for imaging and visual applications. The Ritchey-Chrétien is a member of the Cassegrain family of telescopes. This unique design offers large-diameter optics while maintaining very short tube lengths, making them extremely portable and versatile.

## Parts List

- 1 Optical tube assembly
- 1 2" Extension ring
- 2 1" Extension rings
- 1 Collimation eyepiece

## Unpacking Your Telescope

Use care when unpacking the shipping carton. We recommend keeping the boxes and all original packaging materials. In the event that the telescope needs to be shipped to another location, or returned for warranty repair, having the proper packaging will ensure that your telescope will survive the journey intact. Returns for refund or exchange will not be accepted without all of the original packaging.

Your new telescope arrives double-boxed (Figures 2a-d). Make certain you are opening from the top of the box to access the accessories packaged in the Styrofoam shell. To access the optical tube simply grasp the Styrofoam piece and lift it out of the box and set it aside for the time being. Once all items have been removed from the box take a moment to confirm that all pieces are present and intact. Refer to the Parts List to aid in identifying the various pieces.

## Setting Up Your Telescope

Your Ritchey-Chrétien optical tube comes ready to use right out of the box. The focuser is attached to the optical tube and ready to accept either visual or photographic accessories. Also included are three individual extension rings (Figure 1). These extension rings are provided to allow multiple visual or photographic accessories to reach focus. These are designed

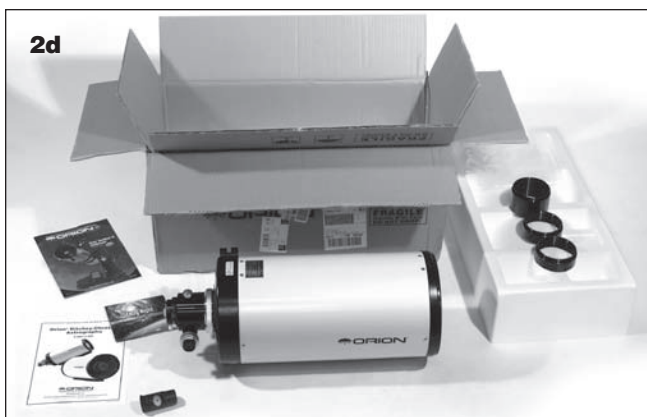

**Figures 2a-d:** Unpacking the Optical Tube.

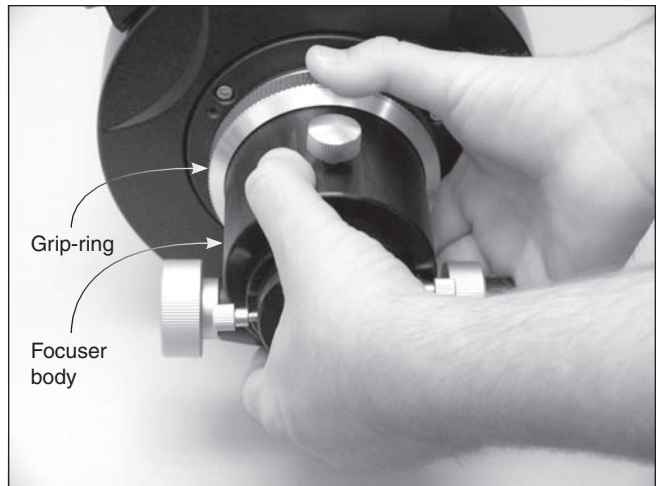

**Figure 3:** Removing the focuser.

to thread directly onto the optical tube. It may be useful to experiment with different combinations during the day before heading out into the field. Choose a target over  $\frac{1}{2}$  mile away to ensure you are simulating distant focus.

If the focuser drawtube is fully extended and you are still unable to achieve focus you will need to install one or more of these extension rings. They are to be installed in-between the focuser and optical tube. In order to install the necessary extension ring(s) you will need to first remove the focuser from the optical tube. Be careful not to cross-thread these pieces when re-attaching adapters.

1. Remove the focuser by holding the focuser body with one hand while gently turning the knurled silver grip-ring with the other (Figure 3). Turn counter-clockwise to loosen.
2. Attach the extension ring of choice to the back end of the tube. The optical tube has external (male) threads. Subsequently you will use the end of the ring with internal (female) threads to attach.
3. The exposed threads on the back of the extension rings match that on the OTA to install additional extension rings or to reattach the focuser.
4. Once you have added the desired number of extension rings re-attach the focuser by aligning the silver grip-ring over the exposed extension ring threads and tighten by carefully turning clockwise (Figure 4a-d).

The wide variety of astronomical equipment available will require that you add or remove some or all of the extension rings. Individual setups will require different combinations of extension rings be used. In general, visual applications will require further extension than imaging. The examples listed and pictured below are of common scenarios. Some setups may require combinations different from those shown in Figure 4.

To set up any Orion StarShoot Deep Space imagers use all three (1 x 2" and 2 x 1") of the supplied extension rings to reach focus. For DSLR and most visual applications use 3" of

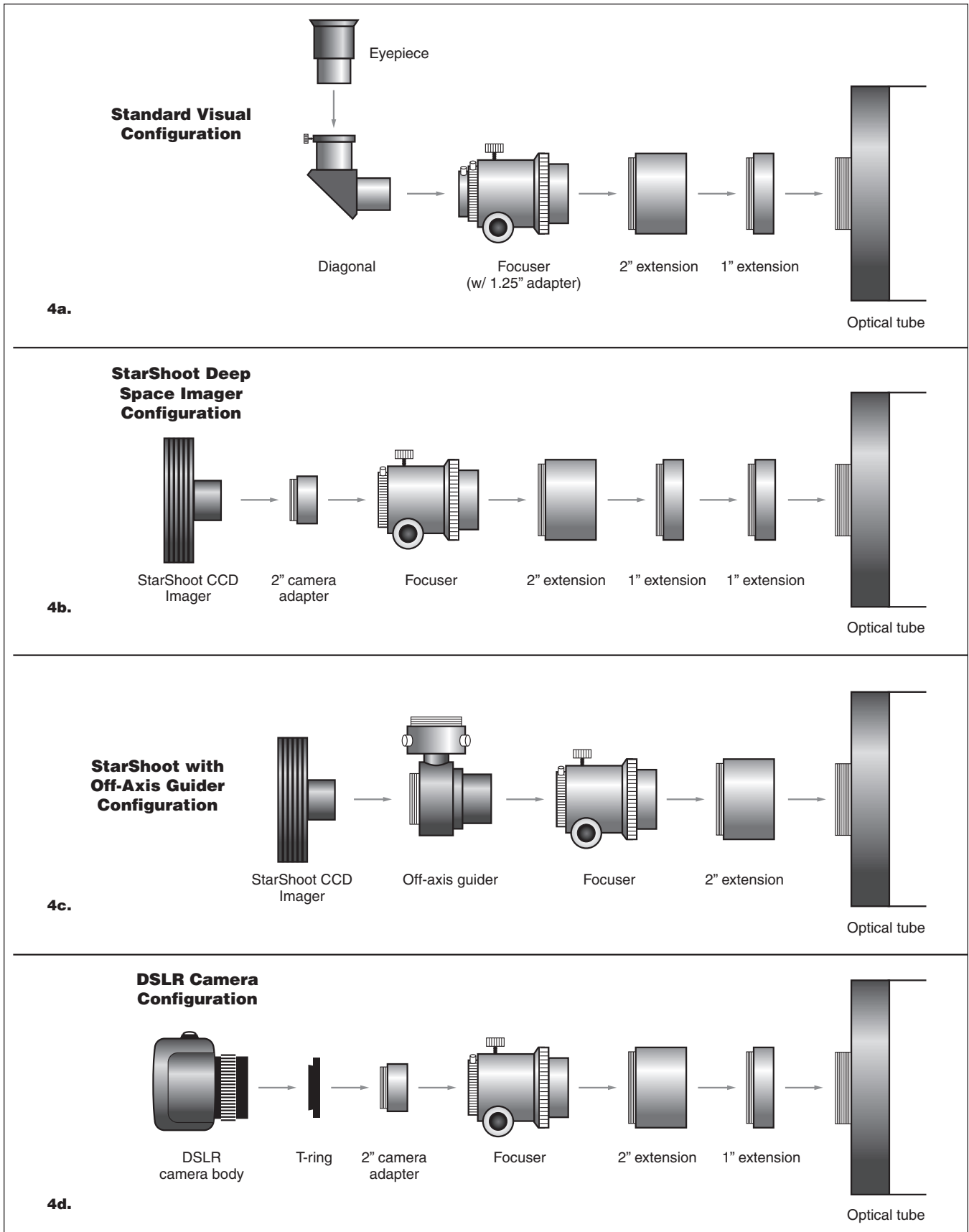

**Figure 4a-d:** Typical visual and imaging configurations for the Ritchey-Chrétien optical tube.

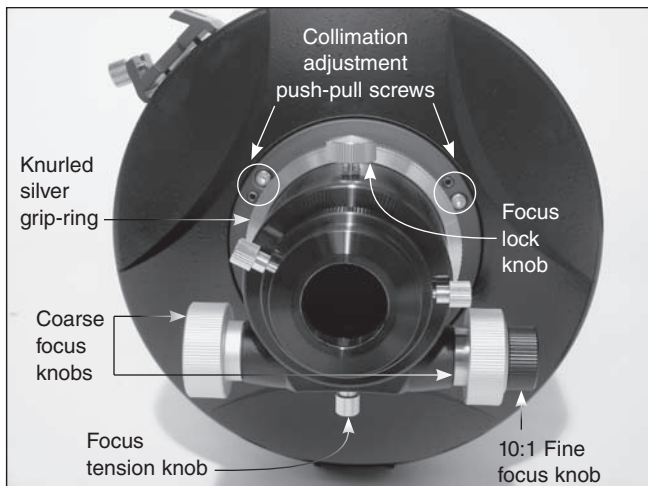

**Figure 5:** Details of the linear bearing Crayford focuser.

extension (1 x 1" and 1 x 2"). Larger 2" eyepieces may only require two inches of extension.

### Focusing the Telescope

One of the exciting new features of the Orion Ritchey-Chrétien optical tubes is the inclusion of the new linear bearing Crayford focuser. Instead of the traditional Crayford-style focuser — which uses a roller tensioned against the drawtube — the new linear bearing focuser has a track on the drawtube with beveled edges and rollers within “grooves” along the edges. This allows you to more effectively lock down the focuser with heavy payloads such as a large eyepiece, a DSLR, or a large CCD Imager. Image shift is reduced by stabilizing the drawtube within the focuser housing.

For astronomical viewing, out-of-focus star images are very diffuse, making them difficult to see. If you turn the focus knob too quickly, you can go right through focus without seeing the image. To avoid this problem, your first astronomical target should be a bright object (like the Moon or a planet) so that the image is visible even when out of focus. There is also a 10:1 fine focus adjustment. Every 10 turns of the small knob equals a single turn of the large knob to enable the micro-adjustment necessary for the sharpest images possible. Use the coarse focus knob to adjust the telescope until your object is as close to focus as possible, then make fine adjustments with the black outside knob

### Attaching a Finder Scope

A finder scope is a small, wide-field instrument used to help locate and center objects in the main field of your telescope. A finder scope usually has a built-in crosshair reticle that shows the optical center of the finder's field of view. On some models the center is indicated with an LED display.

A finder scope dovetail base has been pre-installed on your Ritchey-Chrétien optical tube assembly making it easy to use any Orion finder and many others using a similar bracket. Installing a finder scope is very simple:

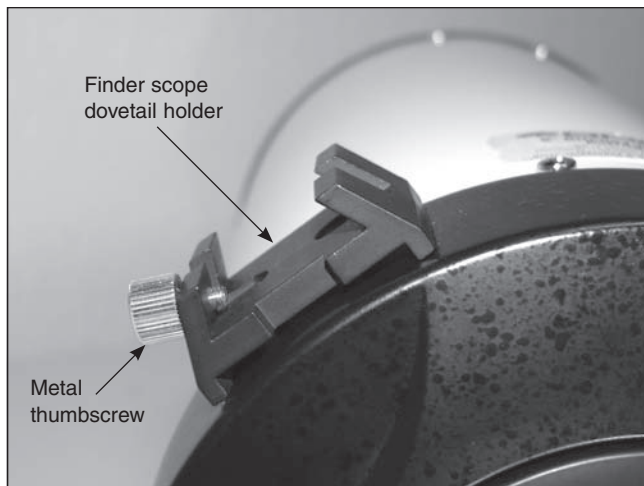

**Figure 6:** Finder scope dovetail base.

1. Loosen the metal thumbscrew on the side of the dovetail base.
2. Insert the bracket into the dovetail from the back of the telescope, until it stops.
3. When the finder bracket is securely in place retighten the metal thumbscrew.

### Inserting a Star Diagonal

A star diagonal is a prism that diverts the light at a right angle to the light path of the telescope. This allows you to observe in positions that are physically more comfortable than if you looked straight through the scope. Your telescope is equipped with a 2" focuser and includes a 1.25" adapter, allowing maximum versatility when choosing accessories. To insert an optional diagonal simply loosen the knurled thumbscrew on the side of the focuser drawtube and insert the chrome barrel of the diagonal, then re-tighten the thumbscrew. The built-in brass compression ring will provide uniform tension on the diagonal and prevent marring of the chrome surface.

### Inserting an Eyepiece

An eyepiece magnifies the image focused by the telescope. The eyepiece fits into either the focuser directly or a star diagonal. Eyepieces are commonly referred to by focal length and barrel diameter. The focal length of each eyepiece is printed on the eyepiece body. The longer the focal length (i.e., the larger the number) the lower the eyepiece magnification, the shorter the focal length (i.e., the smaller the number) the higher the magnification. Generally, you will use low to moderate powers when viewing. Use the following formula to calculate magnification:

$$\text{Magnification} = \frac{\text{Focal Length of Telescope (mm)}}{\text{Focal Length of Eyepiece (mm)}}$$

To install an optional eyepiece:

1. Loosen the setscrew on the star diagonal until the tip no longer extends into the inner diameter of the eyepiece end of the diagonal.

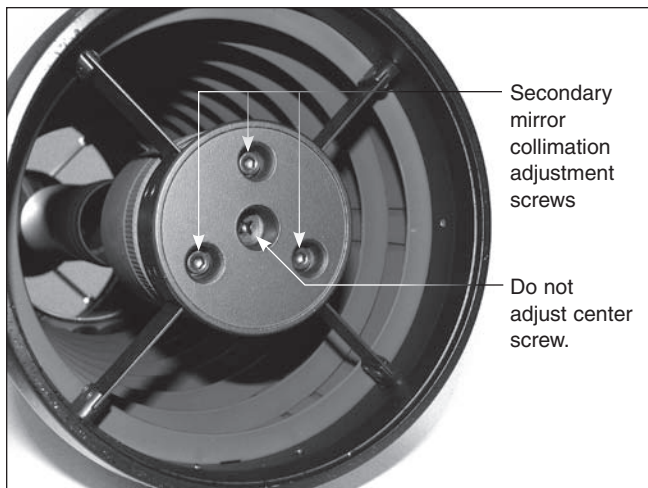

**Figure 7:** The secondary mirror collimation adjustment screws.

2. Slide the chrome portion of the eyepiece into the star diagonal.
3. Tighten the setscrew on the star diagonal to hold the eyepiece in place.

To remove the eyepiece, loosen the setscrew on the star diagonal and slide the eyepiece out. You can replace it with another eyepiece (purchased separately).

### Image Orientation

The image orientation changes depending on how the eyepiece is inserted into the telescope. When using the star diagonal, the image is right side up but reversed from left to right (i.e., mirror image). If inserting the eyepiece directly into the focuser without the star diagonal, the image will be upside-down and reversed from left to right (i.e., inverted). This is normal for the Ritchey-Chrétien design.

## Collimating the Ritchey-Chrétien

The optics in your new Ritchey-Chrétien optical tube have been aligned at the factory. However, rough handling during transit may require periodic re-adjustments. We have center-marked the secondary mirror and included a collimation eyepiece to aid in this process.

### Using the Collimating Eyepiece

This is the recommended procedure for most users. Set up your telescope in a well-lit room with the telescope pointed horizontally. It is best to remove the lens cover and point the telescope at a white (or light colored) wall. Remove all of the extension rings and attach the focuser directly to the optical tube. Insert the collimation eyepiece into the focuser using the 1.25" eyepiece adapter. When peering through the collimation eyepiece you should see a small black dot centered within a

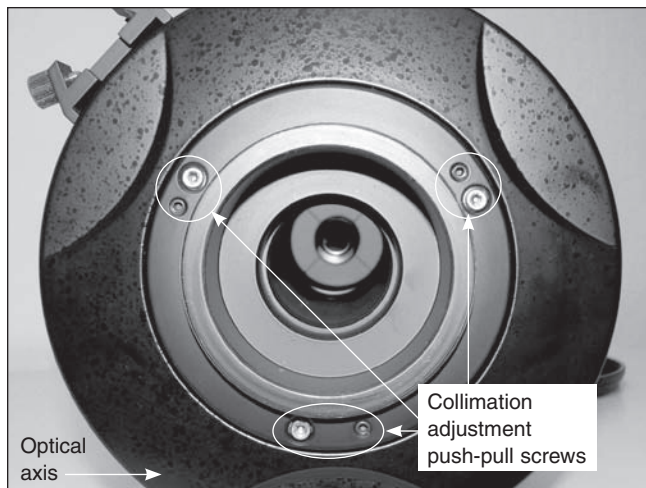

**Figure 8:** The Ritchey-Chrétien with the focuser removed to show the three sets of optical axis adjustment screws. For illustration only: do not remove the focuser when performing collimation.

donut-like ring (Figure 9). The central black dot is the mark of the collimation eyepiece and the ring is the center target on the secondary mirror. The big white circle outside that is the reflected surface of the collimation eyepiece and the larger black circle outside that is the secondary holder. The optical axis is denoted by a thin white circle on the outer edge. You can disregard that for the time being; it will be covered in the following section. If this is aligned as in Figure 9a, no further adjustments will be necessary. If it appears as in Figure 9b — with the dot of the collimation eyepiece not centered in the secondary center mark — adjust the three collimation screws at the front of the secondary mirror holder. This will adjust the tilt of the secondary changing the relative position of the secondary mark when peering through the collimation eyepiece.

### Secondary Adjustment

**NOTE:** Only adjust the three screws around the perimeter of the holder. Do not adjust the center screw. Adjusting the center screw can cause the secondary mirror to fall off and will not be covered under warranty (Figure 7).

A 4mm hex key is required to perform collimation on the secondary mirror. When adjusting one of these screws you will need to make equal counter-adjustments to the other two. Therefore, if you are tightening one screw you will need to loosen, by an equal amount, the other two. When the process is complete you should have tension against all three screws. Adjust the screws by no more than ¼ turn at a time. Only minor adjustments should be required to achieve collimation. This will also aid in the prevention of accidentally putting the telescope grossly out of collimation. Experiment with different combinations until the collimation eyepiece mark is centered in the center ring of the secondary mirror. The correct alignment of the secondary mirror is critical in determining if the optical axis requires alignment. Be certain you have properly aligned the secondary mirror before proceeding to the next step.

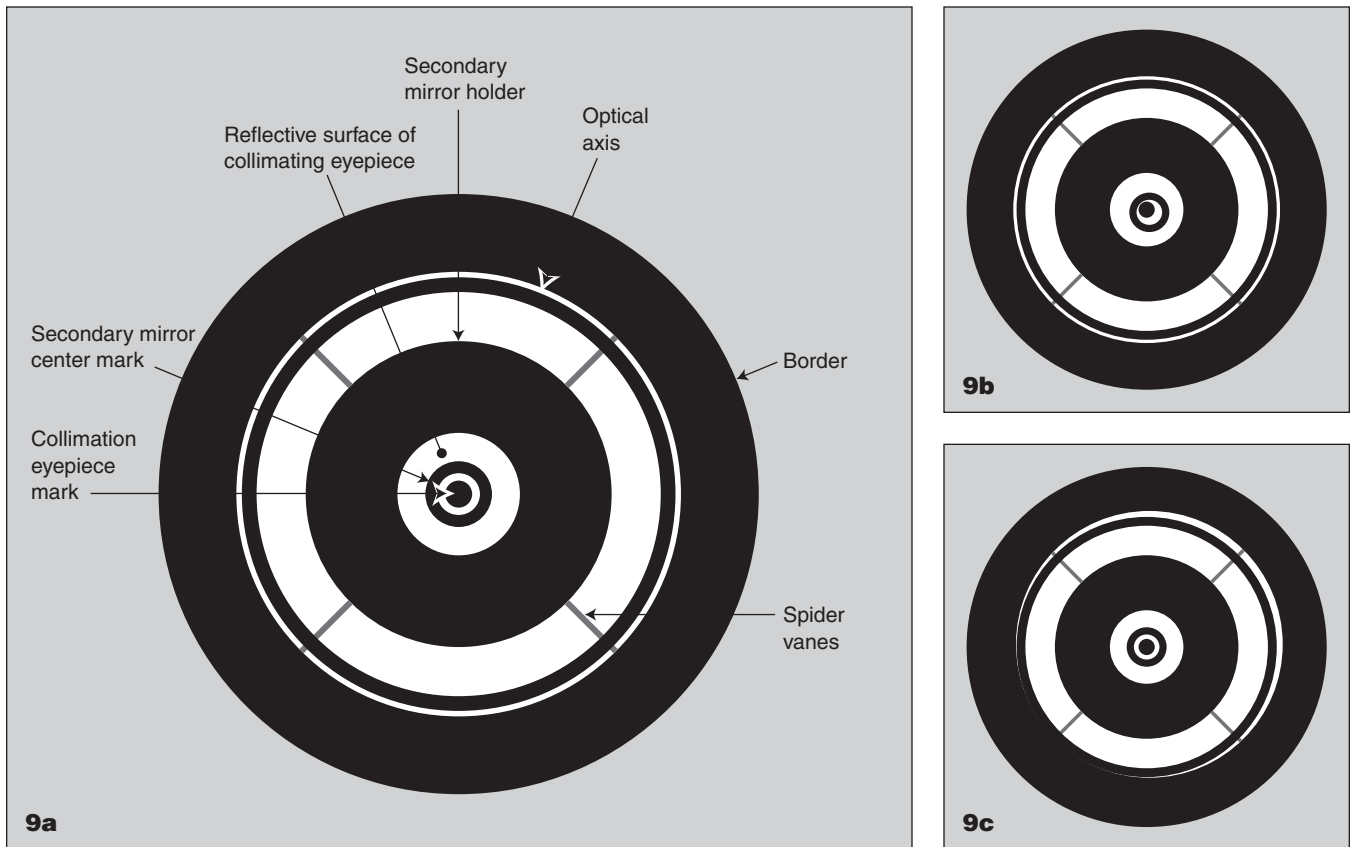

**Figure 9a-c:** The view through the collimating eyepiece (not to scale). Figure 9a shows the Ritchey-Chrétien aligned with all components identified. Figure 9b shows the secondary out of alignment. Figure 9c shows the optical axis out of alignment.

### Optical Axis Adjustment

These adjustments will require a 3mm and 2.5mm hex key. There are three sets of “push-pull” screws on the back-end of the optical tube where the focuser attaches (Figure 8). The optical axis is denoted by a thin outline of light around the perimeter of the view through the collimating eyepiece. Each set consists of a smaller black screw and a larger chrome screw; these must be adjusted in tandem. Loosen one and tighten the other to make changes to the optical axis. This will adjust the tilt of the optical axis in relation to the secondary mirror. If the optical axis is not aligned, the entire image through the collimating eyepiece will appear as if it is tilted to one side (Figure 9c). When properly aligned you will see a very thin concentric outer white circle around the perimeter of your view through the collimation eyepiece. This procedure will require only micro-adjustments, if any.

### Star Testing

An optional star test can be performed to confirm the collimation accuracy of the telescope. The adjustment procedure on the telescope is the same as using the Collimation eyepiece; testing, however, will be done in the night sky. This method is more difficult as you will need to keep your target star centered in your field of view. Furthermore, seeing conditions will affect the end result. Keeping the star precisely centered in the field of view is critical to avoid false negatives. It is sug-

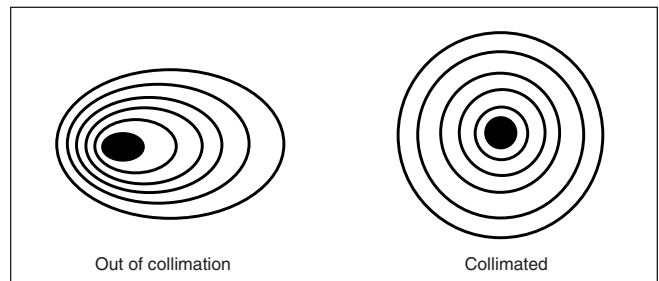

**Figure 10:** An unfocused view of a bright star through the eyepiece. Proper collimation will show a symmetrical diffraction pattern such as the one on the right. If the circles are unsymmetrical the scope needs collimation.

gested that you choose a star close to the zenith (straight overhead) rather than at the horizon to minimize atmospheric distortions. Using Polaris as your target star can be helpful as minimal drift adjustments will be required.

Center a bright star in your field of view using moderate to high magnification. Place your eyepiece directly into the focuser. Do not use a star diagonal while performing this procedure. In a well collimated telescope, a defocused star image should appear symmetrical, with the dark central obstruction centered in the star’s ring pattern (Figure 10).

---

## Care and Cleaning of the Optics

Do not disassemble the Ritchey-Chrétien for any reason, including to clean the mirror. A small amount of dust and particulates on the mirror's surface will not affect performance. In

the event internal cleaning is necessary the telescope should be shipped to Orion Telescopes and Binoculars for service. This telescope does not contain user-servicable parts and disassembly of the components will void the warranty. When not in use, please use the supplied dust cap(s) to keep dust and particulates out of the tube and off the optics.

## Specifications

### 6" f/9 Ritchey-Chrétien

Optical configuration	Ritchey-Chrétien
Figure	Hyperbolic
Mirror material	BK-7
Mirror Coating	Enhanced, no less than 94% with SiO <sub>2</sub> Overcoat
Focuser	Machined Aluminum Dual-Speed (10:1) Linear Bearing Crayford
Accessories	Accepts 2" & 1.25"
Baffles	8 knife-edge baffles
Optical Tube	Steel
Aperture	150mm (6")
Focal Length	1370 mm
Focal Ratio	f/9
Secondary Mirror Minor Axis Length	67mm
Diameter	193mm
Weight	12.4 lbs.

### 8" f/8 Ritchey-Chrétien

Optical configuration	Ritchey-Chrétien
Figure	Hyperbolic
Mirror material	BK-7
Mirror Coating	Enhanced, no less than 94% with SiO <sub>2</sub> Overcoat
Focuser	Machined Aluminum Dual-Speed (10:1) Linear Bearing Crayford
Accessories	Accepts 2" & 1.25"
Baffles	10 knife-edge baffles
Optical Tube	Steel
Aperture	200mm (8")
Focal Length	1600mm
Focal Ratio	f/8
Secondary Mirror Minor Axis Length	90mm
Diameter	230mm
Weight	15.9 lbs



---

## **One-Year Limited Warranty**

The Orion Ritchey-Chrétien Astrographs are warranted against defects in materials or workmanship for a period of one year from the date of purchase. This warranty is for the benefit of the original retail purchaser only. During this warranty period Orion Telescopes & Binoculars will repair or replace, at Orion's option, any warranted instrument that proves to be defective, provided it is returned postage paid to: Orion Warranty Repair, 89 Hangar Way, Watsonville, CA 95076. Proof of purchase (such as a copy of the original receipt) is required.

This warranty does not apply if, in Orion's judgment, the instrument has been abused, mishandled, or modified, nor does it apply to normal wear and tear. This warranty gives you specific legal rights, and you may also have other rights, which vary from state to state. For further warranty service information, contact: Orion Customer Service (800) 676-1343; support@telescope.com.

**Orion Telescopes & Binoculars**  
**OrionTelescopes.com**

**89 Hangar Way, Watsonville CA 95076**

**Customer Support Help Line (800) 676-1343**