

Orion® Deluxe 100mm f/6 Refractor

#7338

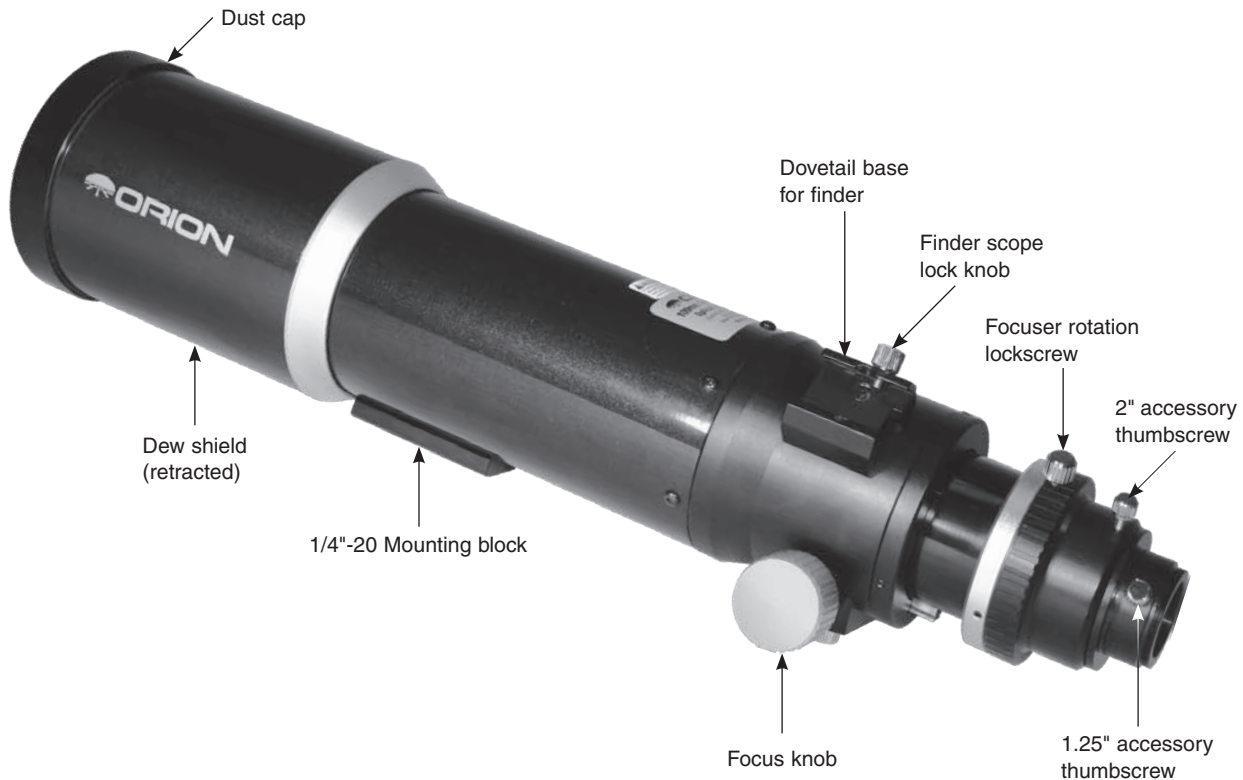

Figure 1: The Deluxe 100mm f/6 refractor optical tube.



OrionTelescopes.com

Customer Support (800) 676-1343 • E-mail: support@telescope.com

Corporate Offices (831) 763-7000 • 89 Hangar Way, Watsonville, CA 95076

© 2008-2010 Orion Telescopes & Binoculars

Congratulations on your purchase of an Orion Deluxe 100mm f/6 optical tube. Your telescope has been designed with high quality precision optics and excellent mechanical construction. The linear bearing dual-speed (10:1) Crayford focuser will make getting sharp images a breeze and reduce image shift to almost zero. The intermediate f/6 focal ratio will show only moderate color fringing. Your new telescope is versatile enough to also be used as a guidescope. These instructions will help you set up and use your optical tube.

Getting Started

The Deluxe 100mm f/6 comes fully assembled from the factory. The telescope's optics have been assembled and collimated at the factory, so you should not have to make any adjustments to them.

Please keep the original shipping box. In the unlikely event you need to ship the telescope back to Orion for warranty repair service, you should use the original packaging. The box also makes a very good container for storing the telescope when it is not in use.

Optical Use

The fine optics and precision machining make the Deluxe 100mm f/6 an excellent choice for astronomical and terrestrial observation. You will need to add an optional diagonal and eyepiece to the back end of the telescope. The telescope will accept 2" or 1.25" accessories. Simply slide your diagonal into the open end of the telescope and insert the eyepiece into the diagonal and it is ready to show you the visual beauty of the night sky.

For terrestrial observation a correct image diagonal is recommended. These are typically available as 1.25" accessories only.

Use of Optional Eyepieces, Diagonal, and Finder Scope

The Deluxe 100mm f/6 does not come with a finder scope, diagonal or eyepieces in order to grant the user the greatest versatility in customizing the instrument to suit their needs. However, certain rules for using accessories still apply.

Any Orion finder scope with a dovetail bracket can be used with the Deluxe 100mm f/6. Simply unthread the thumbscrew on the dovetail mount and insert the assembled finder scope and dovetail bracket. Retighten the thumbscrew (Figure 1). Finder scopes that do not use a dovetail bracket will need to be attached by other means.

The Deluxe 100mm f/6 can use 1.25" accessories. Please note that the telescope will not come to focus without the use of a diagonal or extension tube. To install a diagonal, unthread the thumbscrew on the 1.25" adapter until it is flush with the interior of the adapter (Figure 1). Insert the diagonal or exten-

sion tube and secure it with the thumbscrew. Then insert the eyepiece into the diagonal or extension tube and secure it with the thumbscrew(s).

Use of 2" Eyepieces and Diagonals

A feature of the Deluxe 100mm f/6 is its ability to also use 2" barrel-diameter eyepieces and diagonals. At low magnifications, 2" eyepieces can give a wider field of view than standard 1.25" eyepieces. This is especially desirable for observing deep-sky objects, as many of them appear quite large, but faint.

To use 2" eyepieces, simply loosen the large thumbscrew on the 2" adapter (Figure 1). Once this thumbscrew is loosened, the entire back end of the focuser, including any 1.25" diagonal and eyepiece that may be attached, comes off, exposing the 2" adapter. Now, insert your 2" diagonal into the drawtube and secure with the thumbscrew loosened previously. Insert a 2" eyepiece into the diagonal, secure it in place with the thumbscrew on the diagonal, and you're ready to observe.

About the 2" Linear Bearing Dual-Speed Crayford Focuser

The Deluxe 100mm f/6 comes equipped with a 2" linear bearing dual-speed Crayford focuser. The linear bearing Crayford design allows for smooth, precise focusing without the image shift that rack-and-pinion and typical Crayford designs experience. The linear bearing is a "track" that guides the drawtube in and out on a precise path to further reduce any wobble in the drawtube which could cause image shift.

There is also a fine adjustment capability on this focuser. Ten turns of the small knob protruding from the right focus knob equals one turn of the coarse adjustment knob. Once you have achieved the best possible focus on an object using the coarse adjustment knob; you can fine-tune your focus using this slow motion knob to make micro-adjustments. This will allow delicate adjustments to be made to get the sharpest images possible.

If you find that the focus adjustment is too hard to turn or does not hold in place properly once you've achieved focus, you can make adjustments to the focuser tension by using the focus tension thumbscrew located on the bottom of the optical tube, between the focus knobs. Make adjustments to this thumbscrew until the focuser motion feels smooth to turn and holds in place when you have obtained focus. It may be necessary to make adjustments when the weight of your accessories change significantly.

Using as a Guidescope

The purpose of the guidescope is to monitor a guide star during long-exposure astrophotography in order to make corrections to the mount's tracking rate. This is done by centering a star on the reticle of the illuminated reticle eyepiece used with the guidescope. By keeping that star centered you assure that the view through the telescope (and imager) remains constant. Without use of a guidescope, the telescope will not

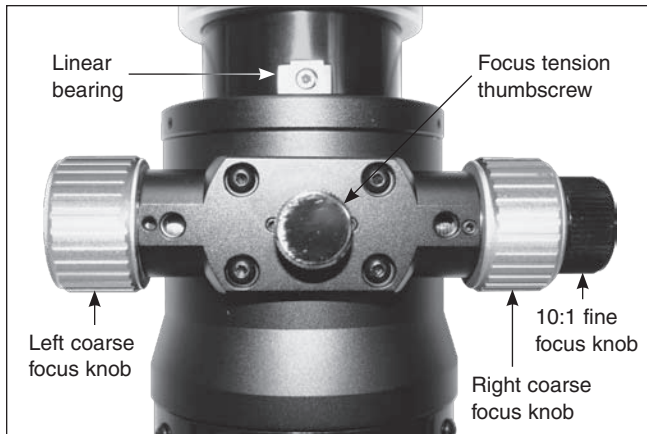

Figure 2: Focuser detail

track the motion of the night sky accurately enough and long-exposure photography will be difficult, if not impossible.

The Deluxe 100mm f/6 comes without accessories. To set up and use the guidescope for use as a guidescope you will need the following:

- 2 Guide scope tube rings
- 1 Guide scope tube ring mounting plate
- 1 Illuminated reticle eyepiece or Autoguider
- 1 Diagonal (optional)

First, adjust the guidescope in the guidescope tube rings so that it is as parallel with the main optical tube. This may involve some large adjustments to the guidescope alignment thumbscrews. Loosen and tighten the alignment thumbscrews as needed to adjust the direction of the guidescope.

Once you have centered the object you wish to photograph, you will need to center the guidescope on a bright star near the object being photographed. Look in the illuminated reticle eyepiece (with the reticle turned on) and select a star that is in the field of view. To center the star, loosen one guidescope alignment thumbscrew and tighten another until the star is centered in the reticle. Check again to make certain that the object you wish to photograph is still centered in its field of view. If it is not, you will have to start the process over again.

Once you begin exposure you will make any adjustments necessary so that the guide star remains centered in the reticle of the illuminated eyepiece.

Photography with the Deluxe 100mm f/6

The Deluxe 100mm f/6 refractor makes a very capable astrograph for your CCD or DSLR camera. With an optional camera adapter, the Deluxe 100mm f/6 becomes a 600mm f/6 telephoto lens for a single-lens reflex camera. For long-distance terrestrial or astronomical photography, you need a T-ring for your particular camera model and a camera adapter. A 2" prime focus camera adapter is suggested to obtain the best focal distance for this optical tube. Simply attach the T-ring

to the camera body and thread the 2" prime focus camera adapter into the T-ring. Insert the barrel of the camera adapter into the 2" eyepiece holder on the focuser. Use the camera's viewfinder to frame the picture. Use the telescope's focuser to focus the image. Tighten the focus tension thumbscrew to make sure the camera does not slip out of focus.

Most CCD cameras will have a 1.25" or 2" barrel ready to attach directly to your telescope like an eyepiece or diagonal. No adapter is required, simply insert the barrel of the CCD camera into the 1.25" or 2" eyepiece holder and secure the camera with the silver thumbscrew lock.

The Deluxe 100mm f/6 Refractors were designed to reach focus with both DSLR and CCD cameras. However, every camera focus point is a little different. Depending on your camera, you may need to use an extension tube for your particular imaging setup. Any imaging accessory, such as a color filter wheel increases the amount of inward focus travel required. Before attaching any extra imaging accessory, try reaching focus first with the camera directly attached to the focuser, then see if you have enough focus travel left for extra accessories.

Imaging equipment is sometimes heavier than a diagonal and eyepiece. The dual-speed Crayford focuser is capable of handling the weight of your CCD or DSLR camera. Adding tension to the focuser drawtube will increase the amount of weight the focuser can handle. Install your camera onto the 2" or 1.25" adapter on the focuser during the day. Check the focuser for any slippage. If the focuser drawtube slides under the weight of the camera, you will need to add more tension to the focuser.

You may want to consider using a remote shutter release instead of the shutter release on the camera. Touching the camera can vibrate the system and blur the resulting photographic image. Also, be sure to use a solid tripod.

Attaching the Deluxe 100mm f/6 to a Tripod or Mount

The Deluxe 100mm f/6 can be attached to a tripod or mount by the use of the pre-installed 1/4"-20 mounting block. The 1/4"-20 shaft of a sturdy camera tripod will thread into the hole on the mounting block on the underside of the optical tube (Figure 1).

Optional tube rings can also be used to mount the 100mm f/6 to attach it to an equatorial mount. Tube rings with an inner diameter of 100mm (3.9"), such as Orion item #7371, are needed. If you are using tube rings, you should first attach them to your telescope mount or dovetail bar and then lay the optical tube in the tube rings. You will need to extend the dew shield in order to accommodate tube rings on each side of the 1/4"-20 mounting block.

Calculating Magnification (Power)

It is desirable to have a range of eyepieces of different focal lengths, to allow viewing over a range of magnifications. To calculate the magnification, or power, of a telescope, simply

divide the focal length of the telescope by the focal length of the eyepiece:

$$\frac{\text{Telescope Focal Length (mm)}}{\text{Eyepiece Focal Length (mm)}} = \text{Magnification}$$

For example, the 100mm, which has a focal length of 600mm, used in combination with a 25mm eyepiece, yields a power of:

$$\frac{600\text{mm}}{25\text{mm}} = 24x$$

Every telescope has a useful limit of power of about 50x per inch of aperture. Claims of higher power by some telescope manufacturers are a misleading advertising gimmick and should be dismissed. Keep in mind that at higher powers, an image will always be dimmer and less sharp (this is a fundamental law of optics). The steadiness of the air (the "seeing") will limit how much magnification an image can tolerate.

Always start viewing with your lowest-power (longest focal length) eyepiece in the telescope. After you have located and looked at the object with it, you can try switching to a higher-power eyepiece to ferret out more detail, if atmospheric conditions permit. If the image you see is not crisp and steady, reduce the magnification by switching to a longer-focal-length eyepiece. As a general rule, a small but well-resolved image will show more detail and provide a more enjoyable view than a dim and fuzzy, overmagnified image.

Care & Maintenance

Give your telescope reasonable care and it will last a lifetime. When not in use, keep its dust cover on as well as the dust cap on the eyepiece opening. Store it indoors or in a dry garage. Do not leave the telescope outside except when using it. The optical tube is aluminum and has a smooth painted surface that should resist scratches and smudges. If a scratch does appear on the tube, it will not harm the telescope. Smudges on the tube can be wiped off with standard household cleaners such as Windex or Formula 409.

Any quality optical lens tissue and cleaning fluid specifically designed for multi-coated optics can be used to clean the telescope's objective lens as well as the lenses of the eyepieces and finder scope. Never use regular glass cleaner or cleaning fluid designed for eyeglasses. Before cleaning with fluid and tissue, however, blow any loose particles off the lens with a blower bulb or compressed air, or lightly brush the lens with a soft camel hair brush. Apply some cleaning fluid to a tissue, never directly on the optics. Wipe the lens gently in a circular motion, then remove any excess fluid with a fresh lens tissue. Oily fingerprints and smudges may be removed using this method. Use caution; rubbing too hard may scratch

the lens! Clean only a small area at a time, using a fresh lens tissue on each area. Never reuse tissues.

Specifications

Objective lens:	Achromatic doublet, air-spaced
Objective lens diameter:	100mm
Objective lens coatings:	All air-to-glass surfaces coated, with at least one surface multi-coated
Focal length:	600mm
Focal ratio:	f/6
Baffling:	Two in optical tube, two in focuser drawtube
Focuser:	2" dual-speed linear bearing Crayford (with 1.25" adapter)
Tube diameter (not including dew shield):	100mm
Tube length (with dew shield):	20.6"
Weight:	7.1 lbs.

One-Year Limited Warranty

The Orion Deluxe 100mm f/6 Refractoris warrantied against defects in materials or workmanship for a period of one year from the date of purchase. This warranty is for the benefit of the original retail purchaser only. During this warranty period Orion Telescopes & Binoculars will repair or replace, at Orion's option, any warranted instrument that proves to be defective, provided it is returned postage paid to: Orion Warranty Repair, 89 Hangar Way, Watsonville, CA 95076. Proof of purchase (such as a copy of the original receipt) is required.

This warranty does not apply if, in Orion's judgment, the instrument has been abused, mishandled, or modified, nor does it apply to normal wear and tear. This warranty gives you specific legal rights, and you may also have other rights, which vary from state to state. For further warranty service information, contact: Orion Customer Service (800) 676-1343; support@telescope.com.

Orion Telescopes & Binoculars

OrionTelescopes.com

89 Hangar Way, Watsonville CA 95076

Customer Support Help Line (800) 676-1343 • Day or Evening

© 2008-2010 Orion Telescopes & Binoculars