

# Instruction Manual

NGC-Series Telescopes

NG-Series Telescopes



[MEADE.COM](http://MEADE.COM)



**MEADE®**





## WARNING!

**Never use a Meade® NGC™ or NG™ Telescope to look at the Sun!** Looking at or near the Sun will cause instant and irreversible damage to your eye. Eye damage is often painless, so there is no warning to the observer that damage has occurred until it is too late. Do not point the telescope or its viewfinder at or near the Sun. Do not look through the telescope or its viewfinder as it is moving. Children should always have adult supervision while observing.

**CAUTION:** Use care to install batteries in the orientation indicated by the battery connector. Follow battery manufacturer's precautions. If these precautions are not followed, batteries may explode, catch fire, or leak. Improperly installed batteries void your Meade warranty.

# CONTENTS

Telescope and Features.....	4
Telescope and Tripod Features .....	6
Getting Started.....	8
Parts Listing .....	8
How to Assemble Your Telescope .....	8
Attaching and Aligning the Red Dot Viewfinder.....	9
Choosing an Eyepiece .....	9
Simple Observations .....	10
Initializing the Control Panel.....	11
Easy Alignment .....	11
Go To Saturn .....	12
Using the Guided Tour .....	14
Menus .....	14
The NGC Menu Structure.....	15
How to Move through the Menu Options .....	15
How to Calculate Sunset Time Example .....	15
Object Menu.....	16
Event Menu .....	16
Glossary Menu.....	17
Utilities Menu .....	17
Setup Menu .....	18
Optional Accessories.....	19
Maintenance .....	20
General Maintenance.....	20
Storage and Transport .....	20
Troubleshooting .....	20
Meade Customer Service .....	21
Specifications.....	21
Appendix A: Advanced Features .....	22
Celestial Coordinates.....	22
Entering Coordinates for Objects not in Database ..	22
To Go to a User-Entered Object .....	23
Landmarks .....	23
To Add a Landmark to the database .....	23
To Select a Landmark from the database .....	23
Appendix B: Entering Time/Date Manually .....	24
Appendix C: Batteries .....	25
Basic Astronomy .....	26

® The name "Meade" and the Meade logo are trademarks registered with the U.S. Patent Office and in principal countries throughout the world. All rights reserved.

Patents:

US 6,392,799

Utility Patent Pending.

© 2005 Meade Instruments Corporation.

# TELESCOPE FEATURES

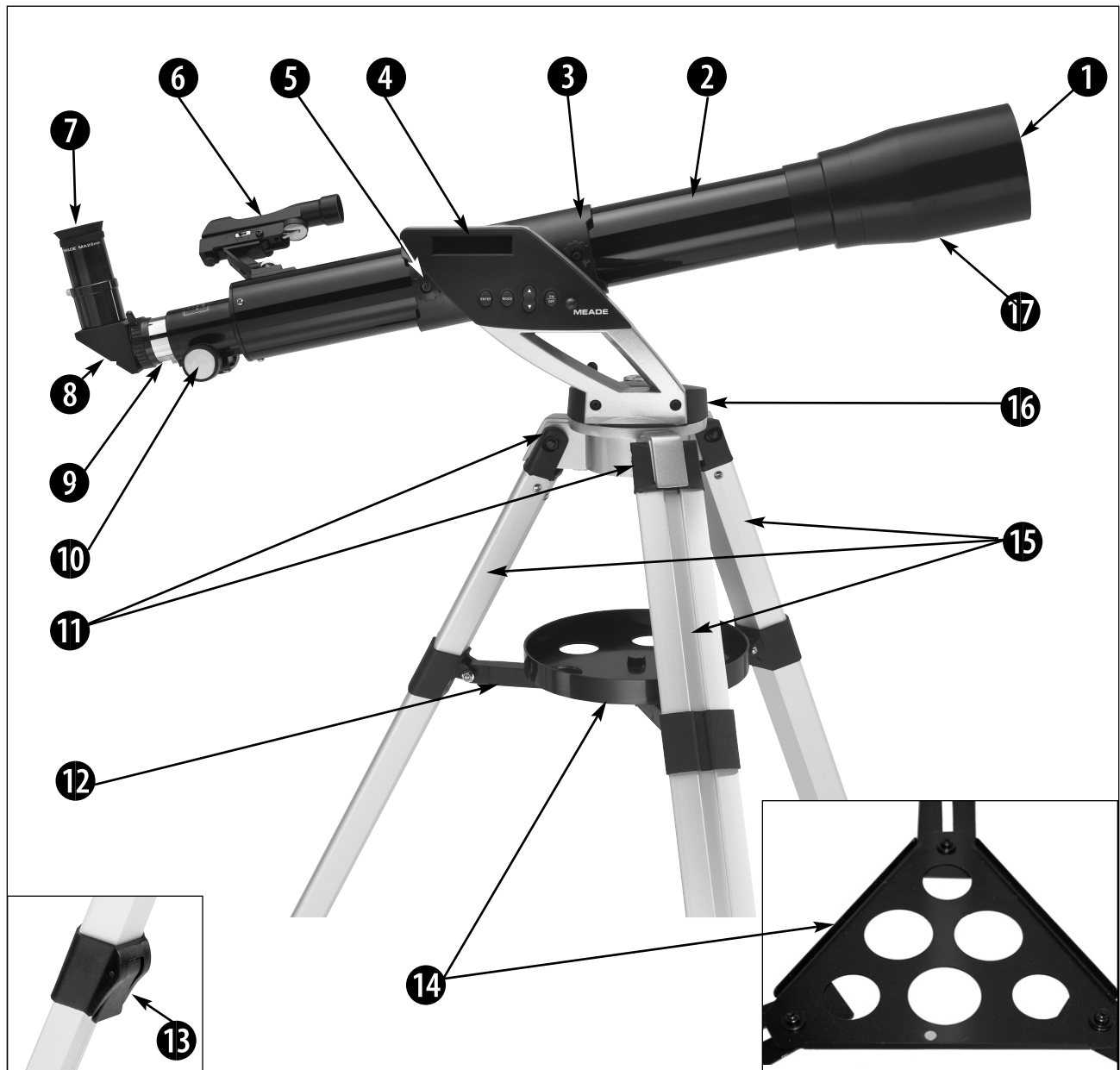
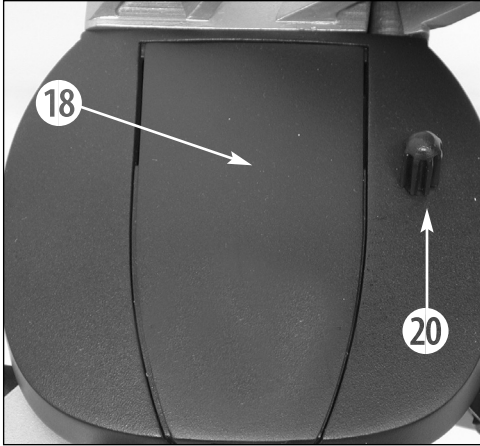

**Fig. 1:** The NGC telescope. **Insets:** Tripod leg lock (13), Alternate tray style (14).

- |                     |  |
|---------------------|--|
| 1. Dust Cap         | 10. Focus Knobs                            |
| 2. Optical Tube     | 11. Tripod Nuts, Bolts                     |
| 3. Tube Bracket     | 12. Leg Brace                              |
| 4. Control Panel    | 13. Leg Lock (inset)                       |
| 5. Attachment Knobs | 14. Tray; (inset:<br>Alternate Style Tray) |
| 6. Red Dot VF       | 15. Tripod Legs                            |
| 7. Eyepiece         | 16. Base                                   |
| 8. Diagonal Mirror  | 17. Dew Shield                             |
| 9. Focuser Drawtube |  |

Your telescope may look different from the one depicted above. Some differences include:

- NG models do not include a control panel (4, Fig. 1) or a battery compartment (18, Fig. 2)
- Accessory tray styles vary (inset Fig. 1)
- Model colors vary



**Fig. 2:** Top view of the NGC base.



**Fig. 3:** Detailed view of the NGC computer control panel.

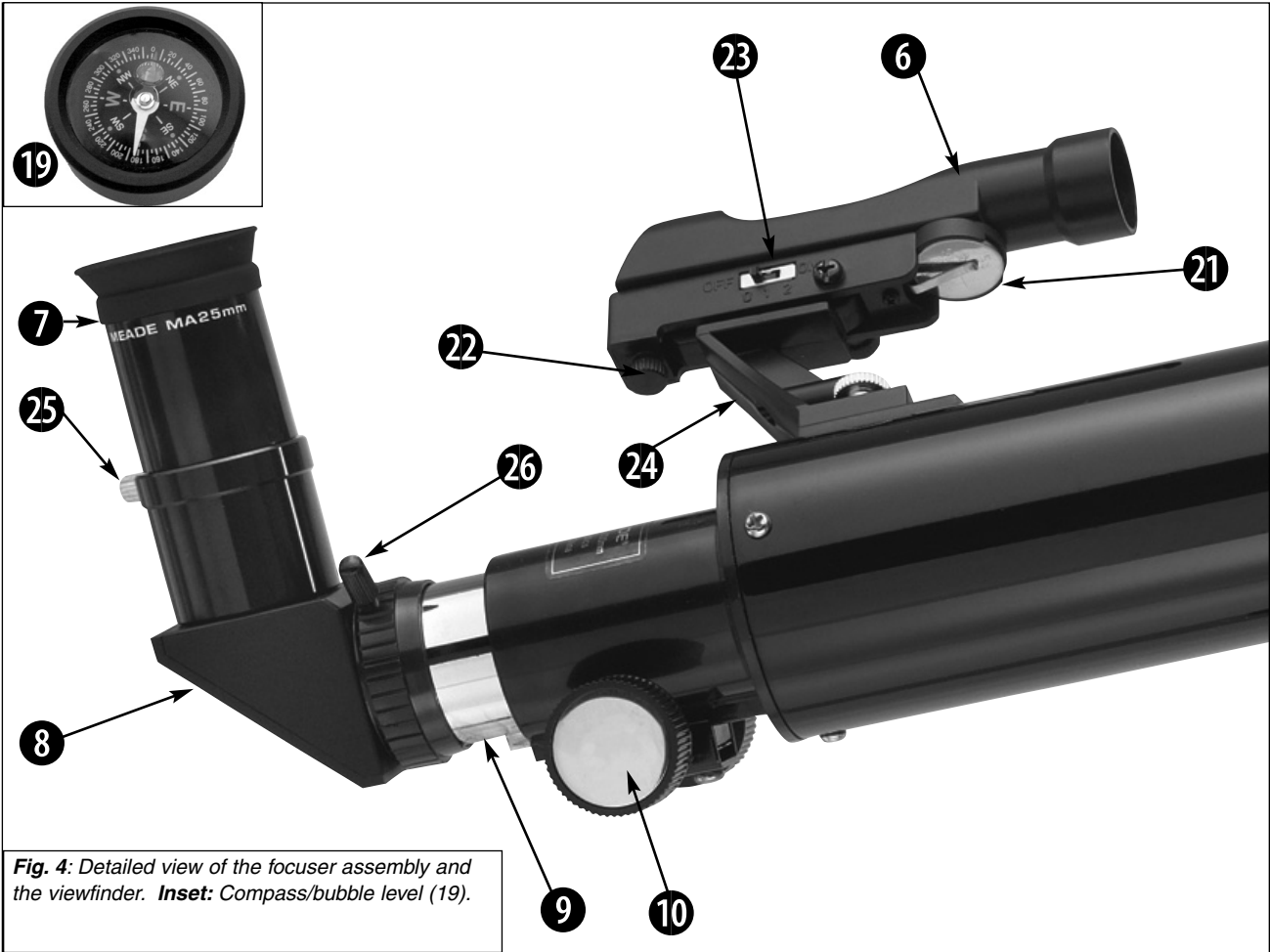

**Fig. 4:** Detailed view of the focuser assembly and the viewfinder. *Inset:* Compass/bubble level (19).

- |                                  |                         |                           |
|----------------------------------|-------------------------|---------------------------|
| 6. Red Dot VF                    | 20. Slow Motion Control | A. Liquid Crystal Display |
| 7. Eyepiece                      | 21. Red Dot battery     | B. Enter Button           |
| 8. Diagonal Mirror               | 22. Alignment Screws    | C. Mode Button            |
| 9. Focuser Drawtube              | 23. Intensity Slider    | D. Up/Down Button         |
| 10. Focus Knobs                  | 24. Red Dot Bracket     | E. On/Off                 |
| 18. Battery Compartment          | 25. Diagonal Thumbscrew | F. Slow Motion Control    |
| 19. Compass/Bubble Level (inset) | 26. Focuser Thumbscrew  | G. AUX Port               |

## Telescope and Tripod Features

- ❶ **Dust Cap (not shown):** Pull to remove from the dew shield (17, Fig. 1).  
*NOTE: The dust cap should be replaced after each observing session and the power turned off (NGC models only) to the telescope. Verify that any dew that might have collected during the observing session has evaporated prior to replacing the dust cap.*
- ❷ **Optical Tube:** The main optical component that gathers the light from distant objects and brings this light to a focus for examination with the eyepiece.
- ❸ **Optical Tube Attachment Bracket:** Attach the optical tube to this bracket. See **HOW TO ASSEMBLE YOUR TELESCOPE**, page 8, for more information.
- ❹ **Control Panel (Fig. 3, NGC Models Only):**
  - A. **2-Line LCD Display:** Displays menus and information concerning the computer controller.
    - **Top line:** Displays menu items.
    - **Bottom line:** Displays menu options or information. *For example,* information about an astronomical object, such as a planet, or information about locating an object.
  - B. **Enter Button:** Accesses, in order, the next menu or option. When a menu option you wish to choose displays, press ENTER to select it. This button is similar to a computer's RETURN key.
  - C. **Mode Button:** Press this button when you wish to return to the previous menu. The MODE key is similar to a computer's ESCAPE key.  
If MODE is pressed and held for two seconds or more, the following information displays:
    - Astronomical coordinates of a selected object
    - Local Time and Local Sidereal Time (LST)
    - Timer and Alarm StatusPress MODE again to return to the previous menu.
  - D. **Up/Down Button:** Use UP/DOWN to scroll through the letters of the alphabet, numerical digits, menus, menu options and other information.
  - E. **On/Off:** Press to turn the control panel on or off.
  - F. **Vertical Slow Motion Control Knob:** Use this control to make fine adjustments in the vertical movement of the telescope.
  - G. **Aux Port:** Use this port, along with the optional #506 Astrofinder Software and Cable Connector Kit, to connect to your PC, or to update celestial objects for your control panel from the Meade website ([www.meade.com](http://www.meade.com)). See **OPTIONAL ACCESSORIES**, page 19, for more information.
- ❺ **Optical Tube Attachment Knobs:** Attach these knobs to the bolts on the optical tube when you attach the optical tube to the bracket. See **HOW TO ASSEMBLE YOUR TELESCOPE**, page 8, for more information.
- ❻ **Red Dot Viewfinder:** Before looking at an object in the eyepiece, locate the object in the red dot viewfinder. The viewfinder provides a much easier way to locate celestial objects than a telescope eyepiece, because it has a wider field of view.
- ❼ **Eyepiece:** Place the eyepiece into the 90° diagonal mirror (8, Fig. 1 or 28, Fig. 4) and tighten the thumbscrew (25, Fig. 4) to a firm feel only. You may also place the eyepiece directly into the focuser drawtube (9, Fig. 1). Use the focus knobs (10, Fig. 1) to focus the eyepiece.
- ❽ **90° Diagonal Mirror:** Holds the eyepiece at a convenient angle for easy viewing. Slide the diagonal mirror into the focuser drawtube (9, Fig. 1) and tighten the thumbscrew (26, Fig. 4) to a firm feel only.
- ❾ **Focuser Drawtube:** Slide the diagonal mirror or an eyepiece into this tube. Tighten the thumbscrew (26, Fig. 4) to a firm feel only.

**NOTE:** Sometimes air gets trapped below the compass dial causing the compass to not work properly.

Gently tap the compass to insure that no air is trapped below the compass dial.

- 10 **Focus Knobs:** Use to move the telescope's focuser assembly to obtain precise image focus. Rotate the focus knobs clockwise to focus on distant objects, and counterclockwise to focus on nearby objects.
- 11 **Tripod Leg Nuts and Bolts (3):** Attach the tripod legs (15, Fig. 1) to the tripod head (16, Fig. 1) using these three nuts and bolts. See **HOW TO ASSEMBLE YOUR TELESCOPE**, page 8, for more information.
- 12 **Tripod Leg Brace Supports:** Stabilizes the tripod and supports the accessory tray. See **HOW TO ASSEMBLE YOUR TELESCOPE**, page 8, for more information.
- 13 **Tripod Leg Lock (3):** Lift the lock to loosen the inner section of a tripod leg and extend the inner leg to the desired height. Press the lock down to lock the leg again.
- 14 **Accessory Tray:** Use the tray to hold extra eyepieces during your observing sessions.
- 15 **Tripod Legs:** Attach the legs to the tripod head (16, Fig. 1). See **HOW TO ASSEMBLE YOUR TELESCOPE**, page 8, for more information. When observing, spread the legs out as far as they will open for a secure viewing platform.
- 16 **Base/Tripod Head:** Supports the telescope for placement on the tripod. See **HOW TO ASSEMBLE YOUR TELESCOPE**, page 8, for more information.
- 17 **Dew shield:** Reduces the formation of dew on the telescope's primary lens and acts as a shade for daytime use.
- 18 **Battery Compartment Lid (NGC Models Only):** Remove the lid to install one user-supplied 9v battery in this compartment. See **HOW TO ASSEMBLE YOUR TELESCOPE**, page 8, for more information.
- 19 **Compass/Bubble Level:** Use the compass to locate North while aligning the telescope. See **EASY ALIGNMENT**, page 12, for more information. When the red arrow of the compass and "N" both point in the same direction, the telescope then points North.  
Use the bubble level to help set the home position. When the bubble is in the center of the compass, the telescope is level.
- 20 **Horizontal Slow Motion Control Knob (NGC Models Only):** Use this control to make fine adjustments in the horizontal movement of the telescope.
- 21 **Red Dot Viewfinder Battery:** Powers the red dot viewfinder. Replace with a CR2032 lithium battery.
- 22 **Red Dot VF Alignment Screws:** Adjust these screws to align the viewfinder. See **ALIGNING THE RED DOT VIEWFINDER**, page 9, for more information.
- 23 **Red Dot VF Intensity Slider:** Slide this switch to lower or intensify the red dot light level.
- 24 **Red Dot VF Bracket:** Holds the red dot viewfinder in place. Attach to the optical tube. See **HOW TO ASSEMBLE YOUR TELESCOPE**, page 8, for more information.
- 25 **Diagonal Mirror Thumbscrew:** Tightens the eyepiece in place. Tighten to a "firm feel" only.
- 26 **Focuser Drawtube Thumbscrew:** Tightens a diagonal mirror or an eyepiece in place. Tighten to a firm feel only.

# GETTING STARTED

## Parts Listing

- Complete optical tube assembly with dew shield, dust cap, red dot viewfinder, and rack-and-pinion focuser; electronic control panel (NGC models only).
- Continuously adjustable aluminum tripod and leg braces.
- Accessories: Eyepieces and 90° diagonal mirror  
Accessory tray  
3 screws (1 1/4" long) with flange nuts and screwdriver tool  
3 screws (1 9/16" long) with hex nuts  
2 nuts for attaching optical tube to bracket (certain models)  
3 cylindrical pins (certain models)

## How to Assemble Your Telescope

Note that although the telescope is unassembled, all of the more difficult or complicated sections of the instrument are already factory pre-assembled. To set up the telescope, follow this procedure:

1. **Identify:** Remove from the gift box and identify the telescope's components, using the listing above.
2. **Tripod - Mount assembly:** The tripod is shipped with the tripod head and the tripod legs unattached. Attach the three aluminum tripod legs (15, Fig. 1) to the tripod head (16, Fig. 1) with the three leg locks facing inward. Line up the holes on the legs with the holes on the mount. Slide a bolt through each hole and tighten with a hex nut. Three 1 9/16" long bolts and three hex nuts are provided for this purpose. See Fig. 5. After attaching the tripod legs, spread the legs evenly apart.
3. **The Tray and Mounting Hardware:** Use the provided three 1 1/4" screws and three flange nuts to attach the leg brace assembly to the tripod leg brace support. You will need a Phillips-head screwdriver to perform this assembly.
4. **Leg Brace Assembly:** Line up one of the leg braces (see Fig. 6) between the opening of one of the tripod leg brace supports on the tripod so that a screw will be able to pass through both the holes of the leg brace support and holes of the leg brace.  
  
Using a Phillips-head screwdriver, thread one of the 1 1/4" screws through the holes. Attach the matching flange nut and tighten to a firm feel. Repeat this procedure until all three leg braces are mounted on the three leg brace supports. See Fig. 6.
5. **Tray Assembly:** To attach the accessory tray to the leg brace assembly, place the round accessory tray over the mounting bolt hole (Fig. 7). Thread the bolt on the bottom of the accessory tray into the the mounting bolt hole (Fig. 7) and turn the tray clockwise (Fig. 8). Tighten to a firm feel, but do not overtighten—you will need to remove the tray if you wish to collapse the tripod. To remove the tray, just rotate the tray counterclockwise. You can then lift and remove the tray.
6. **Set tripod leg height:** Lift the tripod leg lock (13, Fig. 1) and extend the sliding center portion of the adjustable height tripod leg (15, Fig. 1) to the desired length. Press the leg lock down to lock.
7. **Attach the optical tube to bracket:** Your telescope comes supplied with one of two styles of optical tube attachment.

**Style 1:** Two bolts extend from the center portion of the optical tube (2, Fig. 1). Slide the bolts through the holes in the bracket (3, Fig. 1). Thread the provided attachment nuts over the bolts and tighten to a firm feel. See Fig. 9a.

**Style 2:** Unthread the cradle lock knob to open the cradle ring. Place the optical tube into the cradle ring. Tighten the lock knob so that it holds the tube loosely. Balance the tube: Slide the tube back and forth until you find a position where the tube remains horizontal (*i.e.*, without tipping up or down). Now tighten the cradle ring lock knob to a firm feel. See Fig. 9b.

**Note:** If the horizontal and/or vertical movement of the optical tube seems to be too loose or too tight, you can adjust the amount of tension in the

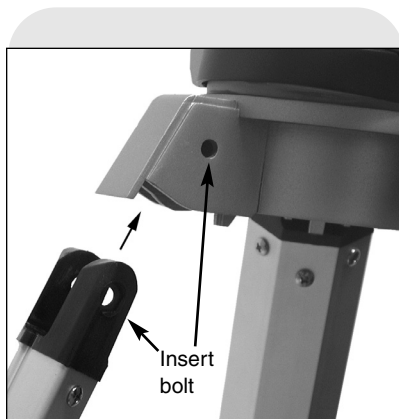

Fig. 5: Attach tripod legs to the tripod head.

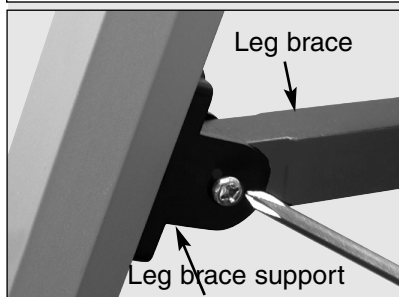

Fig. 6: Attach the leg braces to the leg brace supports.

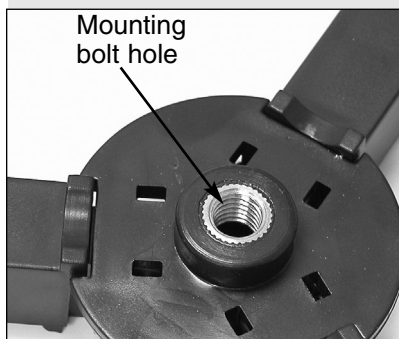
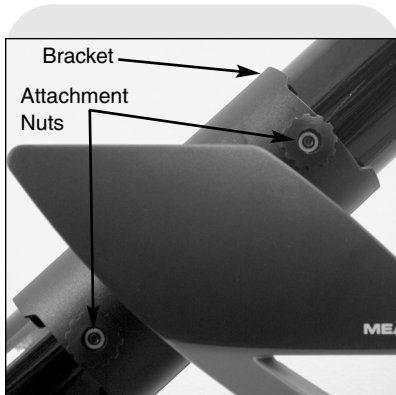

Fig. 7: Mounting bolt hole.

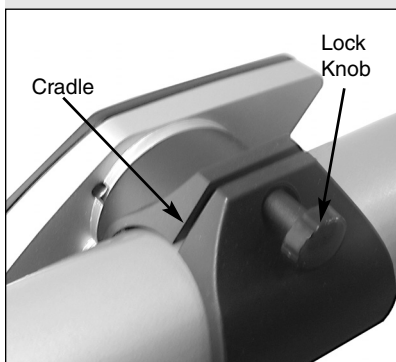

Fig. 8: Place tray onto the mounting bolt hole and thread the bolt on the bottom of the tray into the mounting bolt hole.





**Fig. 9a:** Attach optical tube to the mount (Style 1).



**Fig. 9b:** Attach optical tube to cradle ring (Style 2).



**Fig. 10a:** Attach red dot viewfinder to the optical tube.

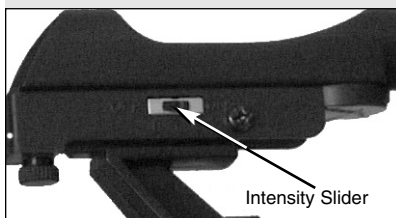

**Fig. 10b:** Slide the intensity slider to make the red dot more or less intense.

movement of the tube to suit your own preference. See **ADJUSTING THE HORIZONTAL AND VERTICAL TENSION OF THE OPTICAL TUBE**, page 20.

8. **Insert the diagonal mirror and eyepiece:** Insert the diagonal mirror (**8, Fig. 1**) into the focuser drawtube (**9, Fig. 1**) and a low-power eyepiece (e.g., 25mm or 26mm eyepiece) into the diagonal mirror. Tighten the eyepiece and diagonal mirror thumbscrews (**25 and 26, Fig. 4**) to a firm feel.

**Note:** Some models are supplied with one of two styles of the 90° diagonal mirror. Quantities of eyepieces and eyepiece size varies with each model.

9. **Install battery (NGC Models Only):** Lift the lid of the battery compartment (**18, Fig. 2**) and attach a 9v battery (user-supplied) to the connector provided in the compartment.
10. **Remove dust cap:** Pull to remove the dust cap from the end of the telescope. Replace it on the telescope at the end of the observing session. The cap keeps the telescope lens free from dust and foreign particles when it is not in use.

## Attaching and Aligning the Red Dot Viewfinder

Because the main telescope has a fairly narrow field of view, locating objects directly in the main telescope can sometimes be difficult. The red dot viewfinder (**6, Fig. 1**) has a wider field of view, which permits you to more easily locate objects. When the red dot viewfinder and optical tube are aligned to each other, both point to the same position in the sky. An object located in the red dot viewfinder is therefore also positioned within the field of the main telescope.

1. **Attach the red dot viewfinder bracket:** Remove the two attachment thumbscrews from the optical tube. These screws are pre-threaded at the factory into the optical telescope tube at the viewfinder location. Line up the holes in the viewfinder bracket with the holes on the tube and thread the thumbscrews back onto the main tube. See **Fig. 10a**.
2. **Setting the intensity slider:** Slide the switch on the side of the red dot viewfinder to the first position for a less intense red dot and to the second position for a more intense red dot. The less intense red dot may be particularly useful when you are sighting on fainter celestial objects. Slide the switch all the way to the left to turn off. **Fig. 10b**.

### To Align the Red Dot viewfinder:

It is recommended that you perform steps 1 and 2 of this procedure during the daytime and step 3 at night.

1. If you have not already done so, place a low-power (e.g., 25mm or 26mm) eyepiece in the diagonal mirror of the main telescope (**8, Fig. 1**) and point the telescope at an easy-to-find land object (e.g., the top of a telephone pole). Turn the focuser knob (**10, Fig. 1**) so that the image is sharply focused. Center the object precisely in the main telescope's field of view.
2. Then, looking through the red dot viewfinder, turn one or both of the red dot viewfinder's alignment screws (**22, Fig. 4**) until the viewfinder's red dot points precisely at the same object as centered in the main telescope. The red dot viewfinder is now aligned to the main telescope.
3. Check this alignment on a celestial object, such as the Moon or a bright star, and make any necessary refinements.

## Choosing an Eyepiece

A telescope's eyepiece magnifies the image formed by the telescope's main optics. Each eyepiece has a focal length, expressed in millimeters, or "mm." The smaller the focal length, the higher the magnification. For example, an eyepiece with a focal length of 9mm has a higher magnification than an eyepiece with a focal length of 25mm.

Low-power eyepieces (e.g., a 25mm or 26mm eyepiece) give a wide, comfortable field of view with high image resolution. High-power eyepieces (e.g., the 9mm eyepiece) provides a smaller field of view but higher magnification when seeing conditions permit.

Low power eyepieces offer a wide field of view, bright, high-contrast images, and eye relief during long observing sessions. To find an object with a telescope, always start with a low power eyepiece (e.g., 25mm or 26mm eyepiece). When the object is

**NOTE:** If you have some familiarity with "Go To" telescopes, you might be wondering why you weren't asked to enter the time and date, the two most important factors in a Go To system.

The reason is that your telescope contains a high-precision internal clock that is set at the factory. The clock has a battery that will hold the time and date information for about 5 years.

If you wish to set the time manually or change the battery, see Appendix B for more information.

**NOTE:** Sometimes air gets trapped below the compass dial causing the compass to not work properly.

Gently tap the compass to insure that no air is trapped below the compass dial.



**Fig. 12:** Remove the eyepiece and slide in the compass/ bubble level.

located and centered in the eyepiece, you may wish to switch to a higher power eyepiece to enlarge the image as much as practical for prevailing seeing conditions.

**NOTE:** Seeing conditions vary widely from night-to-night and site-to-site. Turbulence in the air, even on an apparently clear night, can distort images. If an image appears fuzzy and ill-defined, back off to a lower power eyepiece for a more well-resolved image (**Figs. 11a and 11b**).

The power, or magnification of a telescope is determined by the focal length of the telescope and the focal length of the eyepiece being used. To calculate eyepiece power, divide the telescope's focal length by the eyepiece's focal length. *E.g.*, a 25mm eyepiece is used with a NGC60 telescope. The focal length of the NGC60 is 700mm (see **SPECIFICATIONS**, page 21).

$$\begin{aligned} \text{Focal length} \div \text{Eyepiece focal length} &= \text{Power} \\ 700\text{mm} \div 25\text{mm} &= 28 \end{aligned}$$

The eyepiece power, or magnification is therefore 28x.

## Simple Observations

If you wish to observe a distant land object, such as a mountain top, you can observe by merely pointing the telescope and looking through the eyepiece.

- Move your telescope to observe distant street signs, mountains, trees and other structures. Use your viewfinder to help site-in on an object.
- Practice focusing objects with the focus knob (**10, Fig. 1**).
- Once you get a feel for how your telescope moves and focuses, try to view something more challenging, like a bird or a distant moving train.

You can also observe stars and objects in the night sky using this method, but note that objects begin to slowly drift across the eyepiece field. This motion is caused by the rotation of the Earth. You'll find that you will need to reposition your telescope from time to time to keep an object in the eyepiece field of view. This is especially true when using high-power eyepieces.

Viewing terrestrial objects requires looking along the Earth's surface through heat waves. These heat waves often cause loss of image quality. Lower power eyepieces, such as 25mm or 26mm eyepieces, magnify these heat waves less than higher power eyepieces. Therefore, lower power eyepieces provide a steadier, higher quality image. If the image is fuzzy or ill-defined, reduce to a lower power eyepiece, where the heat waves do not have such an effect on image quality. Observing in early morning hours, before the ground has built up internal heat, produces better viewing conditions than during late afternoon hours.

If you have an NGC model telescope, you can locate stars and other celestial objects (over 1400 objects in all) using the control panel. In order to do so, you must initialize the control panel, set the telescope in the home position, and align the telescope. The control panel uses this information to determine the location of celestial objects.

## Initializing the Control Panel (NGC Models Only)

1. Make sure that you have installed a 9v battery in the battery compartment.
2. Press ON/OFF to turn the power on.  
The control panel display lights up and a copyright message displays briefly.
3. The next screen requests the status of Daylight Savings Time. Use UP/DOWN to move between the "Yes" and "No" settings. Select the desired setting by pressing ENTER.

**NOTE:** Daylight Savings Time may be referred to by a different name in various areas of the world.

**NOTE:** When multiple choices are available within a menu option, the current option is usually displayed first and highlighted by a right pointing arrow (>).

3. The Location screen displays. This screen asks you if you wish to choose either the zip code of your observing location or the location (*i.e.*, entering the city and state or country of your observing location). Press Up to the zip code option or down to enter the city and state.

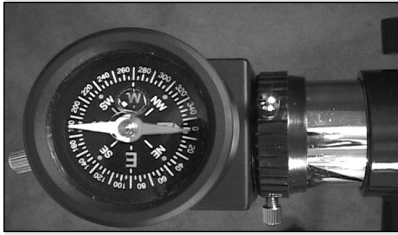

**Fig. 13:** Move the optical tube until the tube points North on the compass.

**Note:** If the horizontal and/or vertical movement of the optical tube seems to be too loose or too tight, you can adjust the amount of tension in the movement of the optical tube to suit your own preference. See **ADJUSTING THE HORIZONTAL AND VERTICAL TENSION OF THE OPTICAL TUBE**, page 20.

**NOTE:** The control panel locates alignment stars based on the date, time, and location entered. The alignment stars may change from night to night.

After displaying "Then Press Enter," the control panel displays two numbers, one on each line. For example: "+35 -115." These two numbers are called "**displacement numbers**" and will assist you in locating a celestial object.

4. **Move the telescope:** Move the telescope tube to the right or left and you will notice the first displacement number getting larger or smaller. Move the tube in the direction that makes the number smaller. Keep moving the tube until the number nears zero. As you near zero, bars appear on the display to make it easier to precisely reach zero. Use the horizontal slow motion control (**20, Fig. 2**) to move the tube in small increments.

After the first displacement number displays zero, move the tube upwards until the second displacement number also nears zero. As you near zero, bars appear on the display to make it easier to precisely reach zero. As you near zero, use the vertical slow motion control (**F, Fig. 3**) to move the tube. You probably will need to make fine adjustments with both displacement numbers as moving the optical tube may slightly shift one or the other displacement numbers.

After both numbers have reached zero, the first alignment star may not appear in the field of view of the eyepiece. However, the alignment star should be easily recognized and be the brightest star in the area of the sky where the telescope is pointing. Look for the star in the viewfinder to see if you can locate it. The viewfinder has a wider field of view than the eyepiece. See **WHICH ONE'S THE ALIGNMENT STAR**, page 13, for more information.

5. **Center the Star:** Once you locate the star, adjust the optical tube using the horizontal and vertical slow motion controls until the star is visible and centered in the eyepiece. When the star is centered, press ENTER.
6. **Repeat the procedure** for the second alignment star. If you have followed the procedure correctly, "Align Successful" displays and the telescope is aligned. You may now use the control panel to locate other stars and objects in the sky. If your alignment was unsuccessful, "Align Unsuccessful" and then "Setup: Easy Align" displays. Press ENTER and repeat the procedure.

## Go To Saturn (NGC Models Only)

After performing the Easy Alignment procedure, the telescope is aligned for a night of viewing.

**IMPORTANT NOTE:** Once aligned, do not move the telescope's tripod and base from the level position or alignment will be lost.

This exercise demonstrates how to select an object for viewing from the control panel's Object menu. The control panel provides an Object menu which displays a list (sometimes called a database) of over 1400 objects you can view with your telescope. This example demonstrates how to select Saturn from the list.

**NOTE:** Saturn is not visible the entire year and you may need to choose another object from the Object menu list; however, the procedure, as described below, remains the same.

- 1 After the telescope is aligned, "Select Item: Object" displays. Press ENTER.
- 2 "Object: Solar System" displays. Press ENTER.
- 3 "Solar System: Mercury" displays. Keep pressing UP/DOWN until "Solar System: Saturn" displays.
- 4 Press ENTER. "Calculating" displays. "Saturn" and its R.A. and Dec. coordinates display. See **APPENDIX A: ADVANCED FEATURES**, for information about celestial coordinates.
- 5 Press ENTER. Next, Saturn's displacement numbers display: "+14 -135."

**NOTE:** Your displacement numbers will be different than the ones in this example. Displacement numbers are determined by location, time, and date.

6. Move the telescope tube to the right or left until you notice the first displacement number getting smaller. Keep moving the tube until the number reaches zero. As you near zero, use the horizontal slow motion control (**20, Fig. 2**) to move the optical tube.

**IMPORTANT NOTE:**

As you observe Saturn, you will notice that the image moves in the eyepiece. This is because the Earth is rotating. You can use the horizontal and vertical slow motion controls (20, Fig. 2 and F, Fig. 3) to re-center the image in the eyepiece. The image will move much faster if you are using a higher-powered eyepiece such as a 4 mm or the 12mm eyepiece.

Next, move the tube upward or downward until the second displacement number also reaches zero. As you near zero, use the vertical slow motion control (F, Fig. 3) to move the optical tube. If you performed the alignment procedure correctly, Saturn will appear in your eyepiece. You may need to center the image.

7. If you wish to display information about Saturn, press MODE and then keep pressing UP/DOWN to scroll through various lines of information. The last line of information displays as a scrolling message. As the message scrolls, you can press UP or DOWN to increase or decrease the scrolling speed.

### Using the Guided Tour (NGC Models Only)

The control panel provides a Guided Tour menu that displays the best objects (and their displacement numbers) to view on any given night of the year. This example demonstrates how to use the "Tonight's Best™" Guided Tour. Other Guided Tours are also provided.

1. After observing Saturn, press MODE twice so that "Select Item: Object" displays again.
2. Press UP/DOWN until "Select Item: Guided Tour" displays.
3. Press ENTER. "Guided Tour: Tonight's Best" displays. Press ENTER.  
*NOTE: If you wish to try out other Guided Tours, press UP/DOWN to scroll through other tour choices. When the tour you wish to select displays, press ENTER.*
4. "Tonight's Best: Searching..." displays. After calculating, "Tonight's Best: Jupiter" displays.

*NOTE: Different objects may be displayed on a tour list on any given night.*

Use the method described in the last section, **GO TO SATURN**, to find Jupiter or any other object displayed on the Guided Tour list. After selecting an item from the list by pressing ENTER, press UP/DOWN to display information about the object.

5. Press MODE to return to the Tour list. Press UP/DOWN to scroll through the list. Press ENTER when you find the next object you wish to observe.
6. Use MODE to leave the Guided Tour menu.

### TIPS for Beginners

#### Which One's the Alignment Star?

If the control panel has chosen an alignment star with which you are unfamiliar, how can you be sure if the star in your eyepiece is really the alignment star?

The rule of thumb is that an alignment star is usually the brightest star in that area of the sky. If you're not sure if you have located the alignment star or it isn't in the eyepiece, look through your viewfinder. When you view an alignment star in the viewfinder, it stands out dramatically from the rest of the stars in that portion of the sky. The viewfinder will help you locate a star more quickly than the eyepiece, because it has a much wider field of view than the eyepiece.

If you have an obstruction, such as a tree or a building blocking your view of the alignment star, or if you have any doubts at all about the star that has been chosen, no problem. Just press UP/DOWN and the control panel will find another star to align upon.

# MENUS

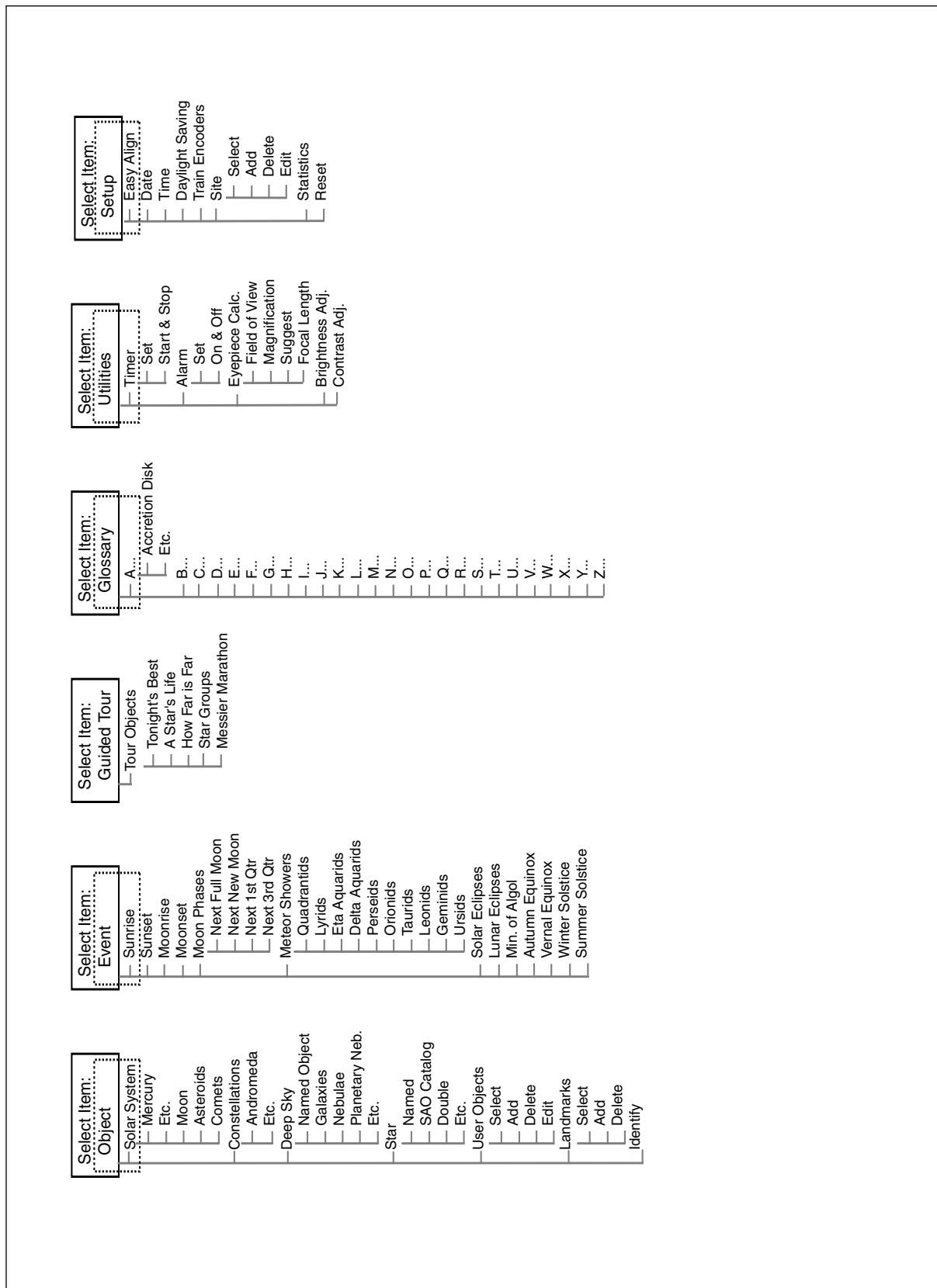

Fig. 14: The NGC Menu structure.

**IMPORTANT**

**NOTE:** No matter how many levels of menus are traveled, each press of the MODE key moves up a level, until the top level, "Select Item," is reached. Once in the Select Item level, press MODE to return to the topmost level, "Select Item: Object."

### How to Move through Menu Options (NGC Models Only):

It is helpful to understand that menu selections are set in a loop. This means that pressing the DOWN button scrolls down through all the available options within a given category, then returns to the first option. Pressing the UP key scroll up through the options in the opposite order. Note that this capability is a quick way to get to an option that is near the bottom of the list. The following example demonstrates this capability.

To navigate to the "Select Item: Setup" menu option when the "Select Item: Object" menu is displayed:

1. Press DOWN five times or UP once.

When the desired option is displayed on the second line, press the ENTER key to choose that option and move down one menu level.

Press the MODE key to leave a level; *e.g.*, the wrong menu option is chosen.

### How to Calculate Sunset time (NGC Models Only):

This example demonstrates how to move through a typical menu and calculate Sunset time. This is an excellent exercise to try out as you can calculate the time when it is going to get dark—and when you can start observing.

1. Press MODE several times, until "Select Item: Object" is displayed.
2. Press UP/DOWN until the "Event" option displays in the "Select Item" menu.
3. Press ENTER to choose the "Event" option and move down a level. "Event: Sunrise" is displayed.
4. Press UP/DOWN to display the "Sunset" option in the Event menu.
5. Press ENTER to choose the "Sunset" option and move down another level.
6. Sunset time displays; calculations are based on the current date, time, and location.
7. Press MODE once to start moving back up through the menu levels. The first level up is the Event menu.
8. Press MODE again to move up another level. This is the top level, "Select Item."
9. Press MODE again to return to the starting point of "Select Item: Object."

### TIPS for Beginners

#### Observing Considerations

- Try to pick an observing site away from street and house lights and car headlights. While this is not always possible, the darker the site, the better.
- Give your eyes about ten minutes to adjust to the darkness before observing. Give your eyes a rest from observing every ten or fifteen minutes to relieve eyestrain.
- Try not to use a standard flashlight. Experienced observers use red LED flashlights or tape red cellophane over their flashlights to use for setup and map reading so they don't have to continually readjust their eyes to the darkness. Be careful not to shine bright lights if there are other observers in the area. Do not shine a flashlight into the telescope while someone is observing!
- Dress warmly. It gets chilly when you're sitting for prolonged periods, even on warm nights.
- Practice setting up your equipment during the day or in a lighted area to become familiar with it before going to a dark site.
- Use a 25mm or 26mm eyepiece to view terrestrial objects and wider areas of space, such as open star clusters. Use optional higher power eyepieces, such as a 9mm eyepiece (see **OPTIONAL ACCESSORIES**, page 19, for more details), when you wish to view something up close, such as craters on the Moon or the rings of Saturn.

**IMPORTANT NOTE:**  
To use the Select and Add features of the Landmark menu, the telescope must be physically located in the same place it was located when the landmark list was created.

Also, the optical tube must be pointed at and centered on the first object in the Landmark list.

## Object Menu

Almost all observing is performed using the Object menu category. (**NOTE: Exceptions include Guided Tour and Landmark Survey.**) See **GO TO SATURN**, page 13, for an example of observing using the Object menu. Also see **USING THE GUIDED TOUR**, page 13.

The Object Menu includes:

**Solar System** is a list of the eight planets (Earth is not included) in order out from the Sun, followed by the Moon, asteroids, and comets.

**Constellation** is a list of all 88 Northern and Southern Hemisphere constellations. When this option is chosen and a constellation name displays (*e.g.*, "Constellations: Aquarius"), press ENTER to select the constellation. You can use UP/DOWN to display lines of information about that constellation on the second line of the display.

Press ENTER when the name of a constellation is displayed to display the name of the brightest star in the constellation. Use UP/DOWN to cycle through the list of important stars in the constellation (these are generally the stars that make up the shape of the constellation), from brightest to dimmest. When the desired star is displayed, press ENTER to select it. You may now use UP/DOWN to scroll through lines of information about the selected star, such as the star's celestial coordinates, brightness, and so forth. The last line of information displays as a scrolling message. As the message scrolls, you can press UP or DOWN to increase or decrease the scrolling speed.

If you press ENTER when information about the star displays, the displacement numbers then display, which tell you how to move the optical tube to locate the star. See **GO TO SATURN**, page 13, for more information about using displacement numbers to locate an object. Use MODE to exit this menu.

**Deep Sky** is a list of objects outside our Solar System such as nebulae, star clusters, galaxies, and quasars.

**Star** is a list of stars listed in different categories such as named, double, variable, or nearby.

**User Objects** allows the user to create his or her own list of celestial objects that are not currently in any other list. See **APPENDIX A**, page 22, for more information.

**Landmarks** stores the location of terrestrial points of interest in the permanent user-created list in the control panel database.

- **Select:** To select a Landmark already in the database, choose the "Select" option and use UP/DOWN to scroll through the list. Press ENTER to select a Landmark. See **LANDMARKS**, page 23, for a detailed procedure.
- **Add:** To add a Landmark, choose the "Add" option. Enter a name for the Landmark. Locate and center the Landmark, then press ENTER. Note that you must be aligned with other landmarks for this feature to work properly. See **LANDMARKS**, page 23, for a detailed procedure.

**Identify** is an exciting feature for an observer who wants to scan the night sky and start exploring. Use this feature after the telescope has been properly aligned. Then follow this procedure:

1. When a desired object is visible in the eyepiece, keep pressing MODE until the "Select Item: Object" menu is displayed. Then press ENTER.
2. Use UP/DOWN to scroll through the Object menu options until the "Object: Identify" screen appears.
3. Press ENTER. The computer control panel searches its lists for the identity of the object being observed.
4. If the object is not in the computer's control panel database, the nearest object in the database is located and displayed on the screen, along with the object's celestial coordinates. Press ENTER and the displacement numbers for the object display. Use the displacement numbers to go to the object, as described in **GO TO SATURN**, page 13.

## Event Menu

The Event menu allows you to display the dates and times of astronomical events. The Event feature includes:

**Sunrise** and **Sunset** calculates the time that the Sun rises or sets on the current date

**NOTE:** *Meteors are fast moving objects that cover large areas of the sky and are usually best observed with the naked eye.*

**NOTE:** *The equinox and the solstice are the days of the year when the seasons change. These days are determined by the location of the Sun in the sky. Vernal means spring.*

and location. Find rise and set times for other dates by entering a new date into the "Setup: Date" menu.

**Moonrise** and **Moonset** calculates the time that the Moon rises or sets on the current date and location. Find rise and set times for other dates by entering a new date into the "Setup: Date" menu.

**Moon Phases** displays the date and time of the next Full, New, 1st Quarter, and 3rd Quarter Moon.

**Meteor Showers** provides information on upcoming meteor showers, such as the Perseids, the Leonids, *etc.* Also lists the dates of the showers and when they reach maximum.

**Solar Eclipse** lists upcoming Solar Eclipses, including the date and type (total, annular, or partial) of eclipse, and the location and time of the first and last contacts of the Moon's shadow. Use UP/DOWN to display the available data. Remember, never use a telescope to look at the Sun! See **WARNING!** page 3.

**Lunar Eclipse** lists upcoming Lunar Eclipses, including the date and type (total, partial, penumbral) of eclipse. Use UP/DOWN to display the available data.

**Min. (Minimum) of Algol** is the minimum brightness of the dramatic eclipsing binary star system, Algol. It is relatively close at a distance of 100 light years. Every 2.8 days during a 10-hour period, Algol undergoes a major change in apparent magnitude as one of the two stars passes behind the other. The combined magnitude of the two stars thus dips from +2.1 to a minimum of +3.4 halfway through the eclipse as the second star is hidden. The computer control panel calculates minimum magnitude time at mid-eclipse.

**Autumn** and **Vernal Equinox** calculates the time and date of the fall or spring equinox of the current year.

**Winter** and **Summer Solstice** calculates the time and date of the winter or summer solstice of the current year.

## Glossary Menu

The Glossary menu provides an alphabetical listing of definitions and descriptions for common astronomical terms and the computer control panel functions. Access directly through the Glossary menu or through hypertext words embedded in the Glossary text. A **hypertext word** is any word in [brackets], usually found when using the Help function or when reading a scrolling message such as a description of a planet or star. Press ENTER whenever a hypertext word is on screen to link directly to the Glossary entry for that word.

To access directly from the Glossary menu, use UP/DOWN to scroll through the alphabet. Press ENTER on the desired letter. Scroll to the desired entry, then press ENTER to read the description.

## Utilities Menu

The Utilities menu provides access to several extra features, including a countdown timer and an alarm. The Utilities functions include:

**Timer** selects a countdown timer. This feature is useful for functions such as astrophotography. To use the Timer, press ENTER, then choose "Set" or "Start/Stop".

- **Set:** Enter the time to be counted down, in hours, minutes, and seconds, then press ENTER.
- **Start/Stop:** Activates the timer set previously. Use UP/DOWN to toggle between ON and OFF. When ON is displayed, press ENTER to activate the timer. When the timer runs out, the display flashes and the timer is deactivated.

**Alarm** selects a time for an alarm signal as a reminder. To use the Alarm, press ENTER, then choose "Set" or "Start/Stop".

- **Set:** Enter the time of day for the alarm to flash, in hours, minutes, and seconds, then press ENTER.
- **Start/Stop:** Activates the alarm set previously. Use UP/DOWN to toggle between ON and OFF. When ON is displayed, press ENTER to activate the alarm. When the alarm time arrives, the display flashes. Press ENTER to deactivate the alarm.

**Eyepiece Calc** calculates information about an eyepiece for your telescope.

- **Field of View:** Scroll through a list of available eyepieces. When an eyepiece is selected, the field of view is calculated.



**NOTE:** Training of the encoders is factory preset and only needs to be done if you have problems with alignment or if the displacement numbers do not change when you move the optical tube.

Time Zone	Shift
Atlantic	-4 Hours
Eastern	-5 Hours
Central	-6 Hours
Mountain	-7 Hours
Pacific	-8 Hours
Hawaii	-10 Hours

Table 1: Time Zone Shift.

- **Magnification:** Scroll through a list of available eyepieces. When an eyepiece is selected, the magnification is calculated.
- **Suggest:** Suggests the best eyepiece for viewing, based on the telescope and the object being viewed.
- **Focal length:** Enter the focal length of your telescope so that the control panel can make the Eyepiece Calc menu calculations. Use UP/DOWN to scroll through the numbers and press Enter after each number is displayed. See **NG AND NGC SPECIFICATIONS**, page 21, to find out the focal length of your telescope.

**Brightness Adj:** Adjusts the brightness of the display using UP/DOWN. When complete, press ENTER.

**Contrast Adj:** Adjusts the contrast of the display using UP/DOWN. When complete, press ENTER. This feature is only required in very cold weather.

## Setup Menu

The Setup menu's primary function is to align the telescope (see page 12). However, there are numerous other features available within the Setup menu, including:

**Date** changes the date used by the computer control panel. This function is useful to check events in the past or future. For example, set the Date menu for a day three months in the future. Then check the "Select Item: Event" menu for the Sunset time on that date. See **EVENT MENU**, page 16.

**Time** changes the time entered into the computer control panel. Setting the correct time is critical for the computer control panel to properly calculate locations and events. Time may be set to 24-hour mode (military time) by selecting the "blank" option which follows the "AM" and "PM" options.

**Daylight Saving** is used to enable or disable Daylight Savings time.

**NOTE:** Daylight Savings Time may be referred to by different names in various areas of the world. Check local time to verify.

**Train Encoders:** If the telescope becomes erratic, try changing the 9 volt battery before performing the Train Encoders procedure.

"Move the Tube UP/DN" displays first. **Very slowly** move the tube up all the way and then down all the way. Press ENTER (do not hold ENTER). You will be asked to do this several times. Next, "Move the Tube E/W" displays. **Very slowly** rotate the tube 360°. You also will be asked to do this several times. When the procedure is complete, "Setup: Train Encoders" displays once again.

**Site** provides access to several options including:

- **Select:** Displays the currently selected observing site and also allows you to select other sites you have entered into a user-defined list (see **ADD** below). Use UP/DOWN to scroll through all available sites in this database. Press ENTER when the site you wish to select displays. Use this option when you move to a different geographic location.
- **Add:** Allows you to add new observing sites to the database (up to six sites may be stored). Scroll through the list of Countries/States. Press ENTER when the site you wish to add displays. Then choose the desired city in the same manner.
- **Delete:** Deletes a stored site from the list.
- **Edit:** Edits a selected site, including: the name, latitude, longitude, and time zone. Time Zone refers to the Greenwich Mean Time (GMT) time zone shift. Users West of Greenwich, England use "-" hours, East of Greenwich use "+" hours. For the United States, look up the time zone shift in Table 1.

**NOTE:** This menu compensates for Daylight Savings time, if that option has been enabled. See **SETUP MENU: DAYLIGHT SAVING**, above.

**Statistics** provides basic statistical data about your system, including:

- **Characters Free:** Shows how much room is available in the user-defined object memory.
- **Version:** Shows the current version of the software.

**Reset** completely resets the computer control panel. You need to initialize the computer control panel after a Reset before proceeding with observations. See **INITIALIZING THE CONTROL PANEL**, page 11.

## OPTIONAL ACCESSORIES

A wide assortment of professional Meade accessories is available for the NG-Series and NGC-series telescopes. **Consult the Meade General Catalog for complete details of these and other accessories.**

**Eyepieces (1.25" barrel diameter):** For higher or lower magnifications with the telescopes that accommodate 1.25" eyepieces, Meade 3-element Modified Achromatic eyepieces, available in focal lengths of 9, 12, 25, and 40mm, provide a high level of image resolution and color correction at an economical price. Alternately, at slightly higher prices, Meade 4-element Series 4000 eyepieces yield wider fields of view with excellent edge-of-field corrections and are available in a large range of focal lengths.

**#126 2x Barlow Lens (1.25"):** For telescopes that accommodate 1.25" eyepieces, the Barlow lens doubles each eyepiece power while maintaining excellent image corrections. *For example*, a 25mm eyepiece used with an NGC60 telescope yields a power of 56X.

**#928 45° Erecting Prism:** The 90° diagonal provided with some telescope models results in upright-but-reversed viewing of land subjects. The #928 45° Erecting Prism (1.25") orients the image correctly in terrestrial applications and provides a comfortable 45° viewing angle.

**Camera Adapter:** NG-series and NGC-series telescopes may be used for through-the-telescope photography of the Moon and planets or for terrestrial objects. For eyepiece-projection photography with any of these telescopes, use the Basic Camera Adapter (1.25"). See the Meade General Catalog for more information.

**#1240 Electric Focuser:** Attaches easily and quickly to any NGC model telescope for smooth, vibration-free focusing. Each focuser includes coarse and microfine speeds. The standard equipment hand controller accepts one (user-supplied) 9-volt battery.

**#506 AstroFinder™ Software and Cable Connector Kit:** Displays more than 10,000 celestial wonders – galaxies, nebulae, star clusters, stars, and planets – on your PC, enabling even the beginner to locate and identify objects to observe with the telescope or to print out star charts for use in observing sessions. Operates with any Windows™-based personal computer. The Cable Connector Kit permits connection of any NGC telescope and PC, for observing your telescope's current position on a PC.

**#546 A.C. Adapter:** Plugs into any standard home outlet and includes a 25 ft. cord. Connects to the 9v DC battery connector in the battery compartment; input voltage to the telescope is 12v DC.

**Electronic Eyepiece™:** Now everyone can easily share views from an eyepiece – of the Moon, planets, stars, and land objects – on a television screen. The built-in NTSC video output allows for direct connection to compatible monitors, VCR's, and camcorders. Continuous capture mode allows you to view and record astronomical and terrestrial images in real time. This easy-to-set up and easy-to-use monochrome CMOS imager offers built-in contrast control adjustment for varying astronomical and terrestrial lighting conditions, and is compatible with both 1.25" and .965" barrel diameters.

### TIPS for Beginners

#### Surf the Web

One of the most exciting resources for astronomy is the internet. The internet is full of websites with new images, discoveries, and the latest astronomical information. You can find websites for almost any topic relating to astronomy on the internet. Check out Meade's website for the latest product and technical information. You'll find our website at:

<http://www.meade.com/>

Here are some other sites you might find interesting:

- *Sky & Telescope:*  
<http://www.Sky and Telescope.com>
- *Astronomy:*  
<http://www.astronomy.com>
- *Astronomy Picture of the Day:*  
<http://antwrp.gsfc.nasa.gov/apod>
- *Photographic Atlas of the Moon:*  
[http://www.lpi.ursa.edu/research/lunar\\_orbiter](http://www.lpi.ursa.edu/research/lunar_orbiter)
- *Hubble Space Telescope Public Pictures*  
<http://opposite.stsci.edu/pubinfo/pictures.html>

# MAINTENANCE AND SERVICING

## General Maintenance

Your telescope is a precision optical instrument designed to yield a lifetime of rewarding applications. Given the care and respect due any precision instrument, your telescope will rarely require factory servicing or maintenance. Maintenance guidelines include:

1. Avoid cleaning the telescope's optics. A little dust on the front surface of the telescope's lens causes virtually no degradation of image quality and should not be considered reason to clean the lens.
2. When absolutely necessary, dust on the front lens should be removed with gentle strokes of a camel hair brush or blown off with an ear syringe (available at any pharmacy). Do not use a commercial photographic lens cleaner.
3. Organic materials (e.g., fingerprints) on the front lens may be removed with a solution of 3 parts distilled water to 1 part isopropyl alcohol. A single drop of biodegradable dishwashing soap may be added per pint of solution. Use soft, white facial tissues and make short, gentle strokes. Change tissues often.

**CAUTION:** Do not use scented, colored or lotioned tissues as damage could result to the optics.

4. If your telescope is used outdoors on a humid night, telescope surfaces may accumulate water condensation. While such condensation does not normally cause any damage to the telescope, it is recommended that the entire telescope be wiped down with a dry cloth before being packed away. Do not, however, wipe any of the optical surfaces. Rather, simply allow the telescope to sit for some time in warm indoor air, so that the wet optical surfaces can dry unattended. In addition, the dust cap should not be placed back on to the optical tube until the telescope is thoroughly dry.
5. If your telescope is not to be used for an extended period, perhaps for one month or more, it is advisable to remove the 9v battery from inside the base. Batteries left installed for prolonged periods may leak, causing damage to the telescope's electronic circuitry.
6. Do not leave your telescope outdoors on a warm day or inside a sealed car for an extended period of time. Excessive ambient temperatures can damage the telescope's internal lubrication and electronic circuitry.

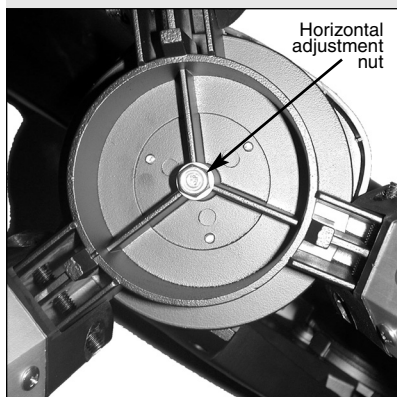

**Fig. 15:** Horizontal adjustment nut.  
(View of the underside of the base.)

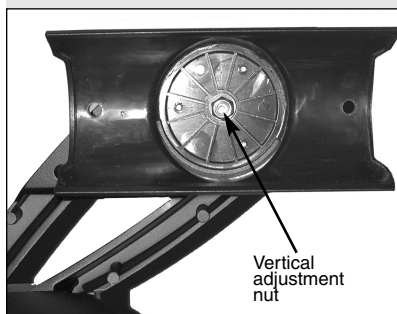

**Fig. 16:** Vertical adjustment nut.  
(Bracket shown with optical tube removed.)

## Adjusting the Horizontal and Vertical Tension of the Optical Tube

If the horizontal and/or vertical movement of the optical tube seems to be too loose or too tight, you can adjust the amount of tension in the movement of the optical tube to suit your own preference. To adjust the horizontal tension of the optical tube, use an adjustable wrench or nut driver to tighten or loosen the horizontal adjustment nut located under the base of the telescope. See **Fig. 15**.

To adjust the vertical tension of the optical tube, first loosen the attachment knobs (5, **Fig. 1**) and remove the optical tube from the bracket (3, **Fig. 1**). Use an adjustable wrench or nut driver to tighten or loosen the vertical adjustment nut located on the inner side of the bracket. See **Fig. 16**. Check the amount of tension by moving the bracket up and down before reattaching the optical tube.

## Storage and Transport

When not in use, store the telescope in a cool, dry place. Do not expose the instrument to excessive heat or moisture. It is best to store the telescope in its original box. If shipping the telescope, use the original box and packing material to protect the telescope during shipment.

When transporting the telescope, take care not to bump or drop the instrument; this type of abuse can damage the optical tube and/or the objective lens.

## Troubleshooting

### Unable to see an image through the eyepiece:

- Confirm that the dust cap has been removed from the telescope.

### Images through the eyepiece appear unfocused or distorted:

- The magnification used may be too high for the seeing conditions. Back off to a lower power eyepiece. See **TOO MUCH POWER?** page 10.

- If inside a warm house or building, move outside. Interior air conditions may distort terrestrial or celestial images, making it difficult, if not impossible, to obtain a sharp focus. For optimal viewing, use the telescope outside in the open air instead of observing through an open or closed window or screen.
- If viewing a land object on a warm day, heat waves distort the image. See **SIMPLE OBSERVATIONS**, page 10.
- For clear viewing of objects, turn the focus knob (**10, Fig. 4**) slowly since the "in-focus" point of a telescope is precise. Turning the focus knob too quickly may cause the focus point to pass without notice.
- The optics within the telescope need time to adjust to the outside ambient temperature to provide the sharpest image. To "cool down" the optics, set the telescope outside for 10 to 15 minutes before observing begins.

**A terrestrial object appears reversed left-for-right:**

- The 90° diagonal mirror yields this image orientation. To view a correctly oriented image, the optional #928 45° Erecting Prism is required. See **OPTIONAL ACCESSORIES**, page 19.

**Meade Customer Service**

If you have a question concerning your telescope, contact the Meade Instruments Customer Service Department at:

**Telephone:** (800) 626-3233  
**Fax:** (949) 451-1460

Customer Service hours are 8:00 AM to 5:00 PM, Pacific Time, Monday through Friday. In the unlikely event that your telescope requires factory servicing or repairs, write or call the Meade Customer Service Department first, before returning the telescope to the factory, giving full particulars as to the nature of the problem, as well as your name, address, and daytime telephone number. The great majority of servicing issues can be resolved by telephone, avoiding return of the telescope to the factory.

**NGC and NG Specifications**

Optical design .....	Refractor
Clear aperture NGC60 /NG60 .....	60mm
Clear aperture NGC70/NG70 .....	70mm
Focal length .....	700mm
Focal ratio .....	60mm - f/11.7; 70mm - f/10
Tripod .....	Aluminum, full-length; adjustable w/accessory tray
Alignment (NGC models only) .....	Altazimuth Easy Alignment (U.S. Patent 6,392,799)
Control knobs (2) (NGC models only) .....	Slow motion control on each axis
Control panel (NGC models only).....	Database of 1400+ objects
Batteries (1) (NGC models only) .....	9v, CR2023, CR-2032, user-supplied
Accessories.....	Red dot viewfinder, 90° diagonal mirror, dew shield

**TIPS for Beginners**

**Star Charts**

Star charts and planisphere are very useful tools. In particular, they are a great aid in planning a night of celestial viewing, as well as assisting in locating celestial objects.

A wide variety of star charts are available in books, in magazines, on the internet and on CD Roms. Meade offers AstroFinder™ and other star locator software. Contact your Meade dealer or Meade's Customer Service department for more information.

*Astronomy and Sky and Telescope* magazines print star charts each month for up-to-the-minute maps of the heavens.

The Norton Star Atlas and Reference Handbook by A. Norton and Sky Atlas 2000 by W. Tirion and R. Sinnott are two of the most popular star charts on the market.

## APPENDIX A: ADVANCED FEATURES

### Celestial Coordinates

A celestial coordinate system was created that maps an imaginary sphere surrounding the Earth upon which all stars appear to be placed. This mapping system is similar to the system of latitude and longitude on Earth surface maps.

In mapping the surface of the Earth, lines of longitude are drawn between the North and South Poles and lines of latitude are drawn in an East-West direction, parallel to the Earth's equator. Similarly, imaginary lines have been drawn to form a latitude and longitude grid for the celestial sphere. These lines are known as **Declination** and **Right Ascension**.

The celestial map also contains two poles and an equator just like a map of the Earth. The poles of this coordinate system are defined as those two points where the Earth's North and South poles (*i.e.*, the Earth's axis), if extended to infinity, would cross the celestial sphere. Thus, the North Celestial Pole (**1, Fig. 17**) is that point in the sky where an extension of the North Pole intersects the celestial sphere. The North Star, Polaris, is located very near the North Celestial Pole (**1, Fig. 17**). The celestial equator (**2, Fig. 17**) is a projection of the Earth's equator onto the celestial sphere.

So just as an object's position on the Earth's surface can be located by its latitude and longitude, celestial objects may also be located using Right Ascension and Declination. *For example:* You could locate Los Angeles, California, by its latitude (+34°) and longitude (118°). Similarly, you could locate the Ring Nebula (M57) by its Right Ascension (18hr) and its Declination (+33°).

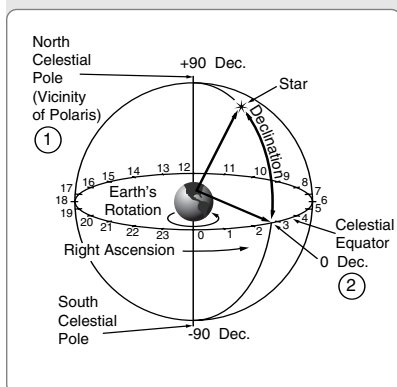

Fig. 17: Celestial Sphere.

- **Right Ascension (R.A.):** This celestial version of longitude is measured in units of hours (hr), minutes (min) and seconds (sec) on a 24-hour "clock" (similar to how Earth's time zones are determined by longitude lines). The "zero" line was arbitrarily chosen to pass through the constellation Pegasus, a sort of cosmic Greenwich meridian. R.A. coordinates range from 0hr 0min 0sec to 23hr 59min 59sec. There are 24 primary lines of R.A., located at 15-degree intervals along the celestial equator. Objects located further and further East of the zero R.A. grid line (0hr 0min 0sec) carry higher R.A. coordinates.
- **Declination (Dec.):** This celestial version of latitude is measured in degrees, arc-minutes, and arc-seconds (*e.g.*, 15° 27' 33"). Dec. locations North of the celestial equator are indicated with a plus (+) sign (*e.g.*, the Dec. of the North celestial pole is +90°). Dec. locations South of the celestial equator are indicated with a minus (-) sign (*e.g.*, the Dec. of the South celestial pole is -90°). Any point on the celestial equator (such as the constellations of Orion, Virgo, and Aquarius) is said to have a Declination of zero, shown as 0° 0' 0."

### Entering Coordinates for Objects not in the Database

Although your computer control panel contains a database of more than 1400 celestial objects (stars, nebulae, planets, etc.) that you can observe, you may eventually want to view objects that are not part of the database. The computer control panel provides a feature that allows you to enter an object's R.A and Dec. coordinates in the "User: Objects" option of the Object menu.

In order to use this menu option, you first need to look up the R.A and Dec. coordinates of the object or objects you wish to observe. Check your local library, computer store, bookstore, CD Roms, Internet, or magazines (such as *Sky & Telescope* or *Astronomy*), to find coordinates of celestial objects. The objects/coordinates you enter become part of your own permanent database, called "User Objects."

#### To enter coordinates of an object into the "User: Objects" option of the Object menu:

1. Make sure the computer control panel has been initialized and the telescope has been aligned.
2. After the telescope is aligned, "Select Item: Object" displays. (If necessary, use UP/DOWN to scroll through the menus, as previously described, to find this option.) Press ENTER.
3. "Object: Solar System" displays. Keep pressing UP/DOWN until "Object: User Object" displays and press ENTER.
4. "User Object: Select" displays. Press UP/DOWN until "User Object: Add" displays. Press ENTER.
5. "Name" displays on the top line and a blinking cursor on the second line. Use UP/DOWN and ENTER, as previously described, to enter the name of the object you wish to add to the database.

6. "Right Asc.: 00.00.0" displays. Use UP/DOWN and ENTER to enter the digits for the Right Ascension coordinate of your object.
7. "Declination: +00°.00'" displays. Use UP/DOWN and ENTER to enter the digits for the Declination coordinate of your object. If necessary, use UP/DOWN to change "+" to "-".
8. The computer control panel then prompts you to enter the size of the object. This step is optional. Use UP/DOWN and ENTER to enter the size (in arc-minutes), if so desired, and press ENTER to go to the next display. If you do not wish to enter this information, simply press ENTER.
9. The computer control panel then prompts you to enter the magnitude of the object. This step is also optional. Use UP/DOWN and ENTER to enter this information, if so desired, and press ENTER to go to the next display. "User Object: Add" displays again.

**To Go To a user-entered object:**

In this procedure, you will choose an object from the User Object list and locate the object.

1. With "User Object: Add" displayed, press UP/DOWN until "User Object: Select" displays. Press ENTER.
2. Use UP/DOWN (if necessary) to scroll to the desired object. Press ENTER.
3. The name of the object and the Right Ascension and Declination coordinates display. Press ENTER. The displacement numbers for the object display.
4. Use the displacement numbers as previously described (see page 12) to locate the object.

**Landmarks**

This menu option allows you to define and store terrestrial objects in the Landmark database. First, a landmark needs to be stored in memory using the "Landmark: Add" option. To view a landmark, use the "Landmark: Select" option. Landmarks may also be viewed using the "Landmark Survey" option in the Utilities menu.

**To Add a landmark to the database:**

In this procedure, you will store the location of terrestrial landmarks in memory.

1. Set the telescope in the home position, if necessary. Note for future reference where the telescope is located.
2. Select the "Select Item: Setup" menu.
3. Press UP/DOWN until "Select Item: Object" displays. Press ENTER. "Object: Solar System" displays.
4. Press UP/DOWN until "Object: Landmarks" displays. Press ENTER. "Landmark: Select" displays.
5. Press UP/DOWN until "Landmark: Add" displays. Press ENTER.
6. "Landmark Name" displays. Using UP/DOWN and ENTER, enter a name for the landmark you wish to add to the database.
7. "Center Landmark. Press Enter" displays. Move the optical tube to the desired landmark and center the object in the eyepiece. Press ENTER. The object is now stored in memory.
8. "Landmark: Add" displays. If you wish to add more landmarks, repeat steps 5 through 7.

**To Select a landmark from the database:**

1. Make sure the telescope is located exactly as when the desired landmark was entered into memory.
2. Display the "Landmark: Select" menu option. Press ENTER.
3. Use UP/DOWN to scroll through the list of objects you have previously entered. When the desired object displays, press ENTER to select the object.  
Press ENTER to display the displacement numbers for the landmark. Use the displacement numbers as previously described (see page 12) to locate the object.
4. Press MODE and then use UP/DOWN to scroll through location information about the object (that you have previously entered), if desired.
5. Press MODE again to exit the Landmark menu.

## APPENDIX B: ENTERING TIME/DATE MANUALLY

### How to manually set the date to March 6, 2005 (NGC Models Only):

1. Press ON/OFF to turn on the control panel.
2. Press the button prompted by the control panel to show that the Sun warning has been read and understood.
3. Keep pressing MODE until "Select Item: Object" displays.
4. Keep pressing UP/DOWN until "Select Item: Setup" displays. Press ENTER.
5. Keep pressing UP/DOWN until "Setup: Date" displays. Press ENTER.
6. "Enter Date: 01-JAN-2003" displays. "0" is highlighted by a blinking cursor. Press ENTER to select "0."
7. "1" is now highlighted. Press UP/DOWN until "6" displays in this position. Press ENTER.
8. "JAN" is now highlighted. Press UP/DOWN until "MAR" displays and press ENTER.
9. "2" is now highlighted. The date display now reads "06 MAR 2003." Press ENTER three times until the "3" is highlighted.
10. Press UP/DOWN until "5" displays in this position. Press ENTER. The date is now entered.

### How to manually set the time to 11:30 p.m. (NGC Models Only):

If you have just set the date, "Setup: Date" displays. Press DOWN once and "Setup: Time" displays. Then proceed to step #6. below.

If you have not yet turned on your control panel, begin with step #1.

1. Press ON/OFF to turn on the control panel.
2. Press the button prompted by the control panel to show that the Sun warning has been read and understood.
3. Keep pressing MODE until "Select Item: Object" displays.
4. Keep pressing UP/DOWN until "Select Item: Setup" displays. Press ENTER.
5. Keep pressing UP/DOWN until "Setup: Time" displays. Press ENTER.
6. "Enter Time: 08:00:00AM" displays. The leftmost "0" is highlighted. Press UP/DOWN until "1" displays. Press ENTER.
7. "8" is highlighted. Press UP/DOWN until "1" displays. Press ENTER.
8. "0" is highlighted. Press UP/DOWN until "3" displays. Press ENTER.
9. Keep pressing ENTER until "AM" is highlighted. Press UP/DOWN until "PM" displays. Press ENTER.
10. The time display now reads "11:30:00PM." The time is now entered.

## APPENDIX C: BATTERIES

Replace the red dot Viewfinder's battery with a CR2032 lithium battery. The battery is located on the bottom of the red dot viewfinder. You may need to slide your fingernail or a screwdriver blade underneath the battery and then slide it out.

Replace the internal clock's battery with a CR2023 lithium battery. This battery is located in the battery compartment.

Both batteries are available from Meade, photographic supply houses or any place lithium batteries are sold.

### TIPS for Beginners

#### Further Study

Below is a small sampling of books, magazines, and organizations that you might find helpful.

##### Books

1. *The Guide to Amateur Astronomy* by Jack Newton and Philip Teece
2. *The Sky: A User's Guide* by David Levy
3. *Turn Left at Orion* by Guy Consolmagno and Dan Davis
4. *Astrophotography for the Amateur* by Michael Covington

##### Magazines

1. *Sky & Telescope*  
Box 9111, Belmont, MA 02178
2. *Astronomy*  
Box 1612, Waukesha, WI 53187

##### Organizations:

1. Astronomical League  
Executive Secretary  
5675 Real del Norte, Las Cruces, NM 88012
2. The Astronomical Society of the Pacific  
390 Ashton Ave, San Francisco, CA 94112
3. The Planetary Society  
65 North Catalina Ave, Pasadena, CA 91106

And watch Jack Horkheimer, *Star Gazer*, on your local PBS station.



# BASIC ASTRONOMY

In the early 17th century, Italian scientist Galileo, using a crude telescope smaller than your NG or NGC, turned it to look towards the sky instead of distant trees and mountains. What he saw, and what he realized about what he saw, forever changed the way mankind thought of the universe. Imagine what it must have been like being the first human to see moons revolve around the planet Jupiter or to see the changing phases of Venus! Because of his observations, Galileo correctly realized Earth's movement and position around the Sun, and in doing so, gave birth to modern astronomy. Yet Galileo's telescope was so crude, he could not clearly make out the rings of Saturn.

Galileo's discoveries laid the foundation for understanding the motion and nature of the planets, stars and galaxies. Building on his foundation, Henrietta Leavitt determined how to measure the distance to stars; Edwin Hubble proposed a glimpse into the origin of the universe; Albert Einstein unraveled the relationship of time and light. Almost daily, using sophisticated successors to Galileo's crude telescope, such as the Hubble Space Telescope and the Chandra X-Ray telescope, more and more mysteries of the universe are being solved and understood. We are living in the golden age of astronomy.

Unlike other sciences, astronomy welcomes contributions from amateurs. Much of the knowledge we have on subjects such as comets, meteor showers, variable stars, the Moon and our solar system comes from observations made by amateur astronomers. So as you look through your telescope, keep in mind Galileo. To him, a telescope was not a mere machine of glass and metal, but something far more—a window of incredible discovery.

## The Glossary

Be sure to make use of the Glossary feature in your NGC computer control panel. The Glossary menu provides an alphabetical listing of definitions and descriptions of common astronomical terms. Access directly through the Glossary menu or through hypertext words. See **GLOSSARY MENU**, page 17, for more information.

## Objects in Space

Listed below are some of the many astronomical objects that can be seen with your telescope:

### The Moon

The Moon is, on average, a distance of 239,000 miles (380,000km) from Earth and is best observed during its crescent or half phase when Sunlight strikes the Moon's surface at an angle. It casts shadows and adds a sense of depth to the view (**Fig. 18**). No shadows are seen during a full Moon, causing the overly bright Moon to appear flat and rather uninteresting through the telescope. Try using a neutral Moon filter when observing the Moon. Not only does it protect your eyes from the bright glare of the Moon, but it also helps enhance contrast, providing a more dramatic image.

Brilliant detail can be observed on the Moon, including hundreds of lunar craters and maria, described below.

**Craters** are round meteor impact sites covering most of the Moon's surface. With no atmosphere on the Moon, no weather conditions exist, so the only erosive force is meteor strikes. Under these conditions, lunar craters can last for millions of years.

**Maria** (plural for mare) are smooth, dark areas scattered across the lunar surface. These dark areas are large ancient impact basins that were filled with lava from the interior of the Moon due to the depth and force of a meteor or comet impact.

Twelve Apollo astronauts left their bootprints on the Moon in the late 1960's and early 1970's. However, no telescope on Earth is able to see these footprints or any other artifacts. In fact, the smallest lunar features that may be seen with the largest telescope on Earth are about one-half mile across.

### Planets

Planets change positions in the sky as they orbit around the Sun. To locate the planets on a given day or month, consult a monthly astronomy magazine, such as *Sky and Telescope* or *Astronomy*. Listed below are the best planets for viewing through your telescope.



**Fig. 18:** The Moon. Note the deep shadows in the craters.



**Fig. 19** Jupiter and its four largest moons. The moons can be observed in a different position every night.

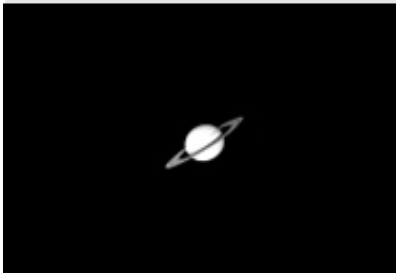

**Fig. 20:** Saturn has the most extensive ring structure in our Solar System.



**Fig. 21:** The Pleiades is one of the most beautiful open clusters.

**Venus** is about nine-tenths the diameter of Earth. As Venus orbits the Sun, observers can see it go through phases (crescent, half and full) much like those of the Moon. The disk of Venus appears white as Sunlight is reflected off the thick cloud cover that completely obscures any surface detail.

**Mars** is about half the diameter of Earth, and appears through the telescope as a tiny reddish-orange disk. It may be possible to see a hint of white at one of the planet's Polar ice caps. Approximately every two years, when Mars is closest to Earth in its orbit, additional detail and coloring on the planet's surface may be visible.

**Jupiter** is the largest planet in our solar system and is 11 times the diameter of Earth. The planet appears as a disk with dark lines stretching across the surface. These lines are cloud bands in the atmosphere. Four of Jupiter's moons (Io, Europa, Ganymede, and Callisto) can be seen as "star-like" points of light when using even the lowest magnification (**Fig. 19**). These moons orbit Jupiter so that the number of moons visible on any given night changes as they circle around the giant planet.

**Saturn** is nine times the diameter of Earth and appears as a small, round disk with rings extending out from either side (**Fig. 20**). In 1610, Galileo, the first person to observe Saturn through a telescope, did not understand that what he was seeing were rings. Instead, he believed that Saturn had "ears." Saturn's rings are composed of billions of ice particles ranging in size from a speck of dust to the size of a house. Titan, the largest of Saturn's moons can also be seen as a bright, star-like object near the planet.

#### Deep-Sky Objects

Star charts can be used to locate constellations, individual stars and deep-sky objects. Examples of various deep-sky objects are given below:

**Stars** are large gaseous objects that are self-illuminated by nuclear fusion in their core. Because of their vast distances from our solar system, all stars appear as pin-points of light, irrespective of the size of the telescope used.

**Nebulae** are vast interstellar clouds of gas and dust where stars are formed. Most impressive of these is the Great Nebula in Orion (M42), a diffuse nebula that appears as a faint wispy gray cloud. M42 is 1600 light years from Earth.

**Open Clusters** are loose groupings of young stars, all recently formed from the same diffuse nebula. The Pleiades is an open cluster 410 light years away (**Fig. 21**). Numerous stars are visible.

**Constellations** are large, imaginary patterns of stars believed by ancient civilizations to be the celestial equivalent of objects, animals, people or gods. These patterns are too large to be seen through a telescope. To learn the constellations, start with an easy grouping of stars, such as the Big Dipper in Ursa Major. Then, use a star chart to explore across the sky.

**Galaxies** are large assemblies of stars, nebulae and star clusters that are bound by gravity. The most common shape is spiral (such as our own Milky Way), but galaxies can also be elliptical, or even irregular blobs. The Andromeda Galaxy (M31) is the closest spiral-type galaxy to our own. This galaxy appears fuzzy and cigar-shaped. It is 2.2 million light years away in the constellation Andromeda, located between the large "W" of Cassiopeia and the great square of Pegasus.





## MEADE LIMITED WARRANTY

Every Meade telescope, spotting scope, and telescope accessory is warranted by Meade Instruments Corporation ("Meade") to be free of defects in materials and workmanship for a period of ONE YEAR from the date of original purchase in the U.S.A. and Canada. Meade will repair or replace a product, or part thereof, found by Meade to be defective, provided the defective part is returned to Meade, freight-prepaid, with proof of purchase. This warranty applies to the original purchaser only and is non-transferable. Meade products purchased outside North America are not included in this warranty, but are covered under separate warranties issued by Meade international distributors.

**RGA Number Required:** Prior to the return of any product or part, a Return Goods Authorization (RGA) number **must** be obtained from Meade by writing, or by calling (800) 626-3233. Each returned part or product must include a written statement detailing the nature of the claimed defect, as well as the owner's name, address, and phone number.

This warranty is not valid in cases where the product has been abused or mishandled, where unauthorized repairs have been attempted or performed, or where depreciation of the product is due to normal wear-and-tear. Meade specifically disclaims special, indirect, or consequential damages or lost profit which may result from a breach of this warranty. Any implied warranties which cannot be disclaimed are hereby limited to a term of one year from the date of original retail purchase.

This warranty gives you specific rights. You may have other rights which vary from state to state.

Meade reserves the right to change product specifications or to discontinue products without notice.



**MEADE**<sup>®</sup>

6001 Oak Canyon, Irvine, California 92618  
(949) 451-1450 ■ [www.meade.com](http://www.meade.com)

14-0060-00 4/05C