

1.200X602X313 mm

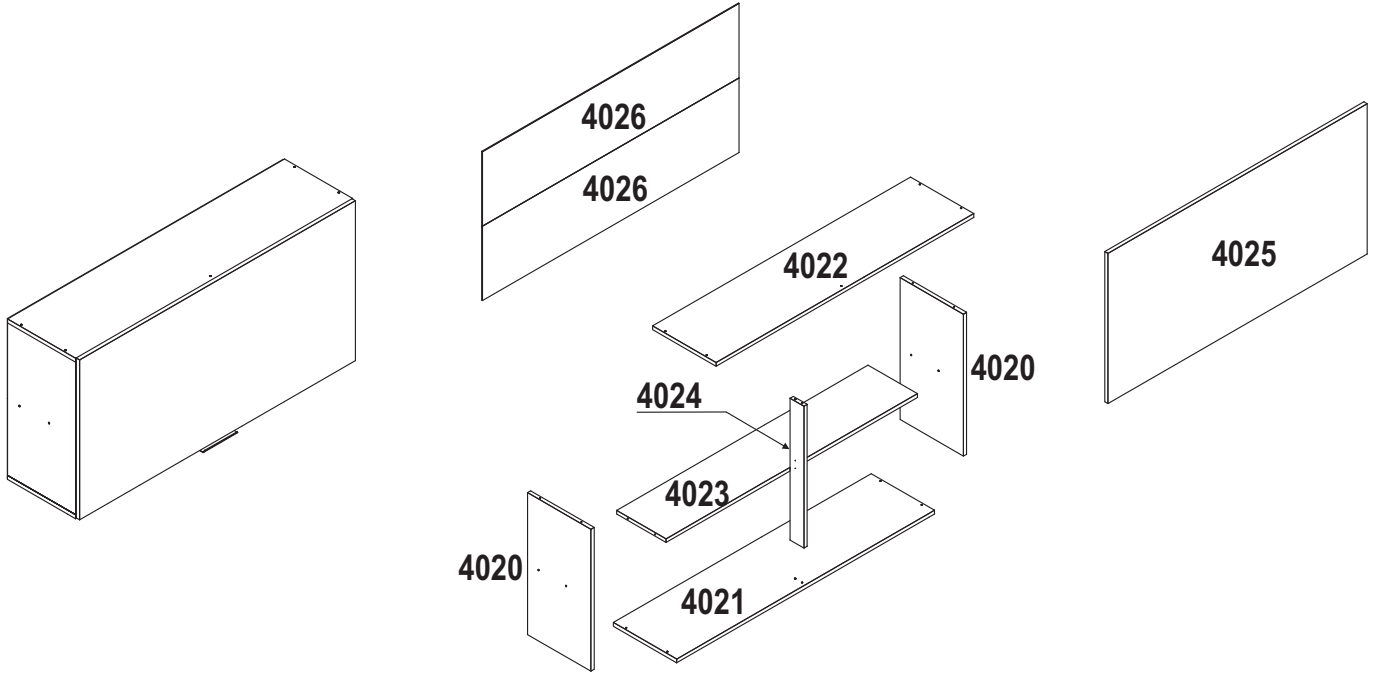

CÓDIGO	DESCRIÇÃO DAS PEÇAS	QTD.	DIMENSÃO = MM
4020	LATERAL	02	295X572X15
4021	BASE INFERIOR	01	295X1.200X15
4022	BASE SUPERIOR	01	295X1.200X15
4023	PRATELEIRA	01	230X1.168X15
4024	BATENTE	01	65X572X15
4025	PORTA	01	600X1.195X15
4026	FUNDO TRASEIRO	02	298X1.195X3

accessories    accesorios    accessoires    acessórios

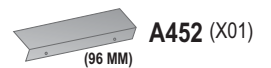

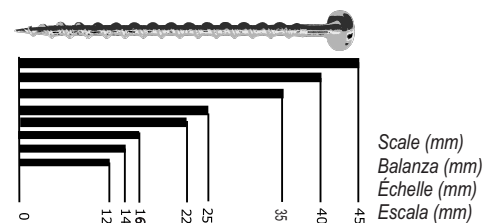
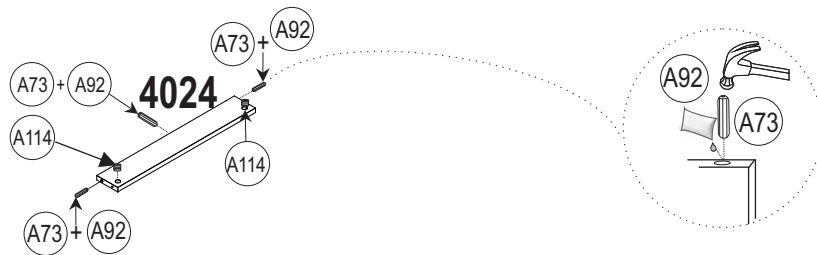
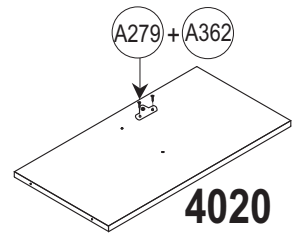
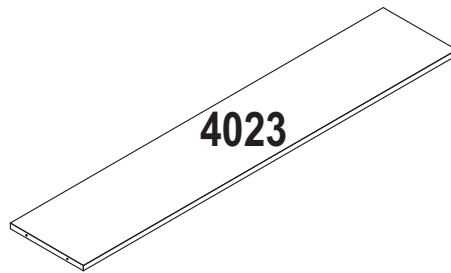
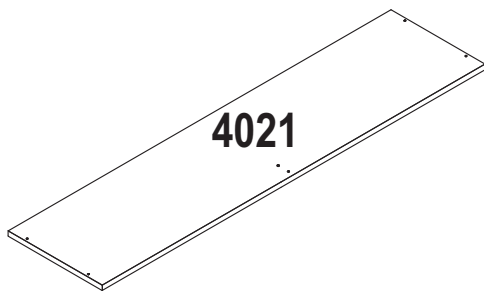
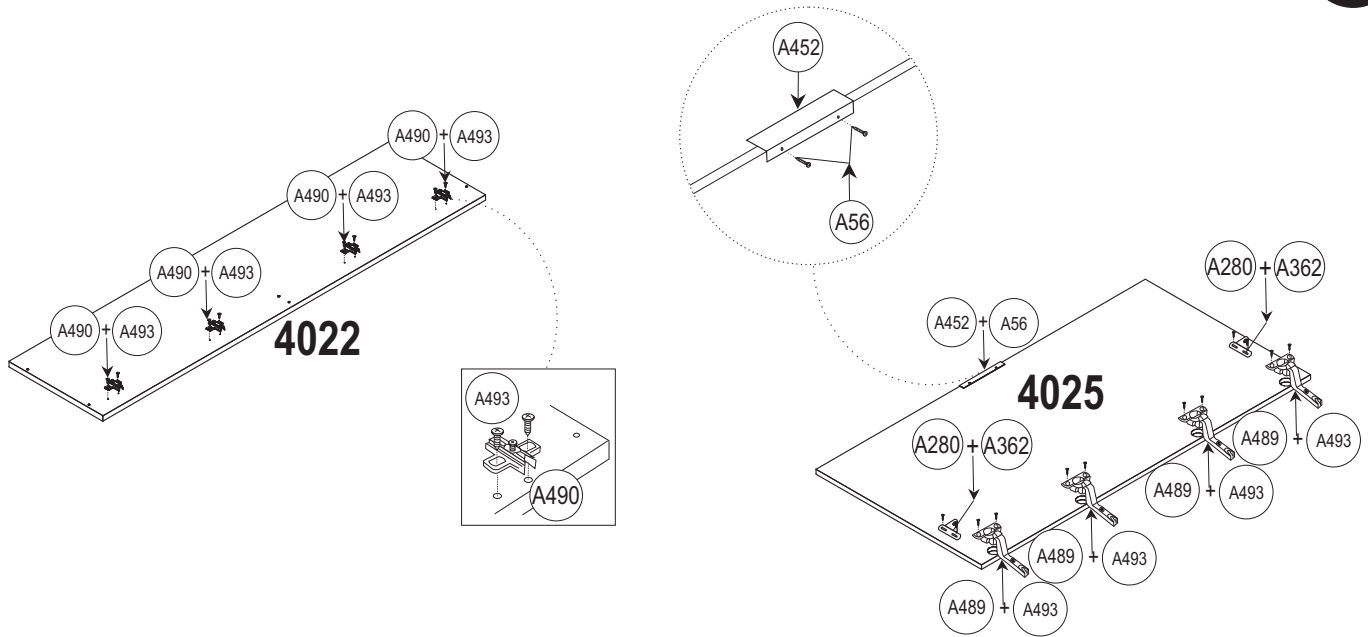

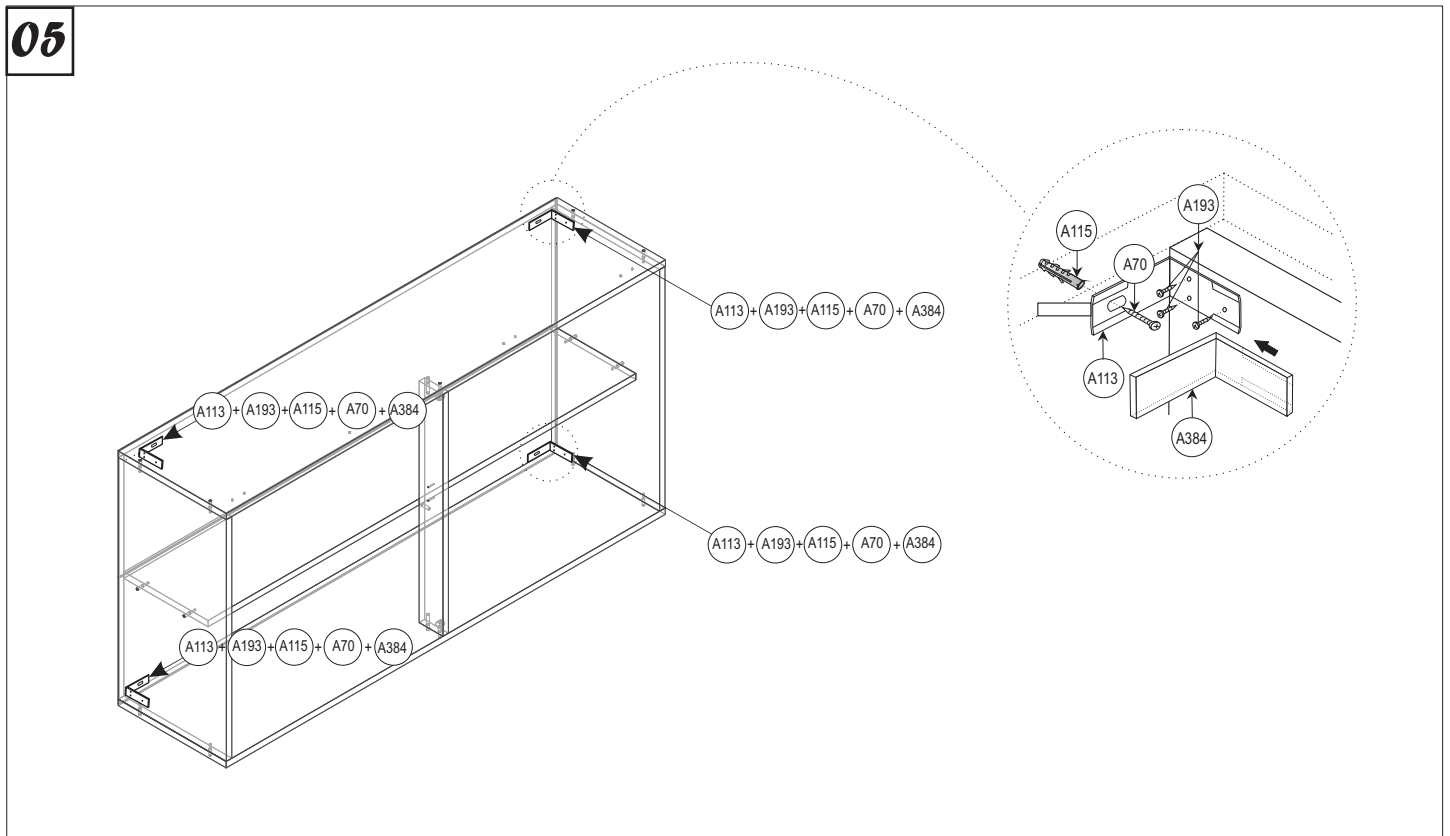
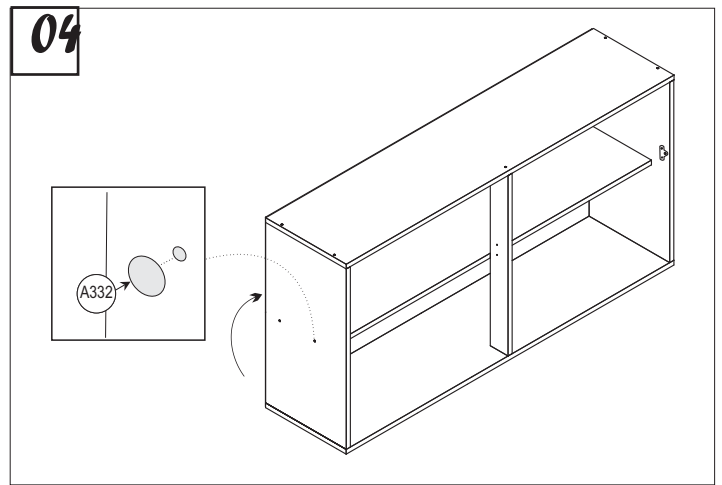
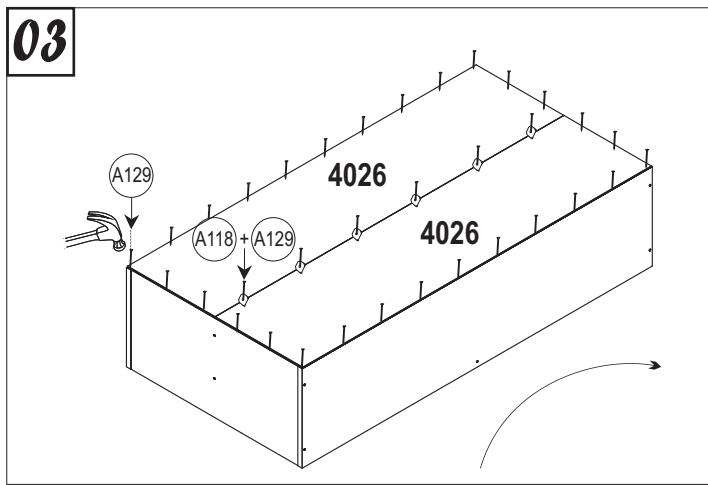
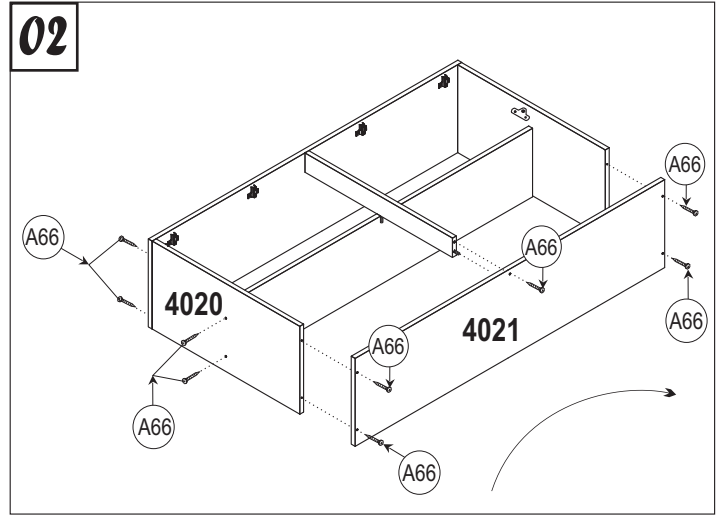
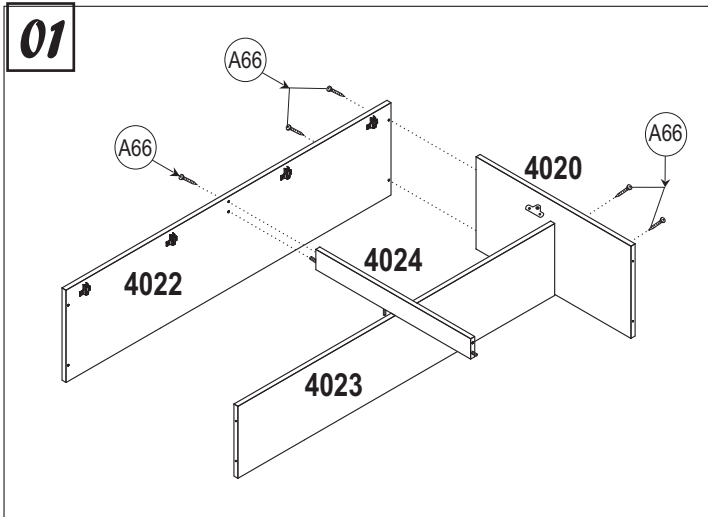

06

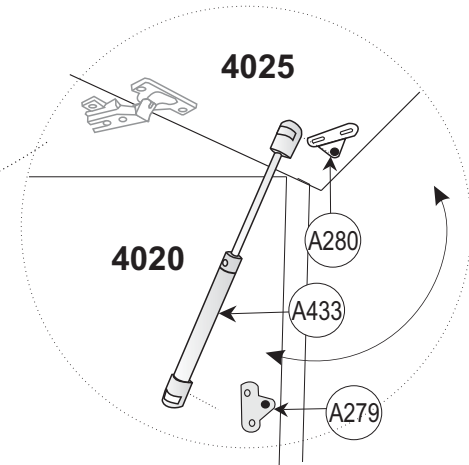
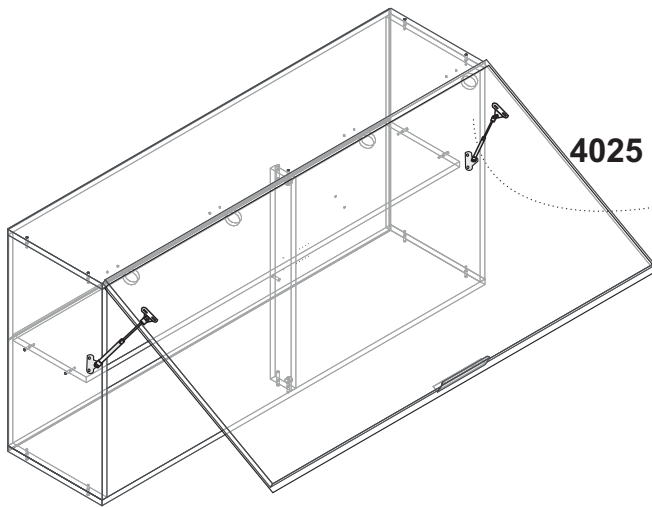

07

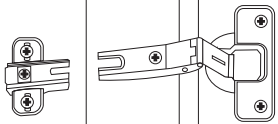

4020

4025

08

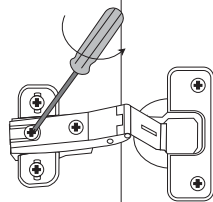

09

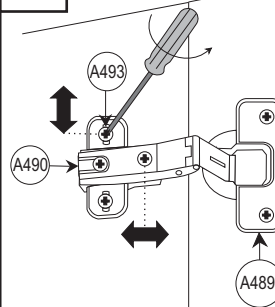

10

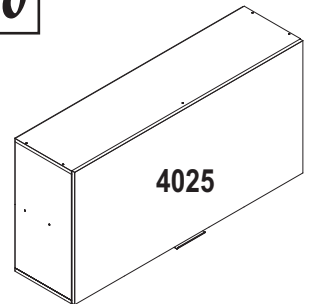

- In order to adjust correctly the door, please observe the picture. In order that the doors stay at the same level the adjustment should be done through the screw A56 from A490 accessory.

- Para ajustar correctamente la puerta, por favor observe la imagen. Para la permanencia de puertas en el mismo nivel el ajuste deberá ser hecho por el tornillo A56 del accesorio de A490.

- Pour ajuster correctement la porte, observez s'il vous plaît l'image. Afin que les portes soient au même niveau l'ajustement devrait être fait par la vis A56 de l'accessoire A490.

- Para o ajuste ideal das portas, observe a foto em destaque. Para que as portas fiquem no mesmo nível, o ajuste deverá ser feito através do parafuso A56 do acessório A490.

peça

piece

pièce

pieza

**Em caso de problemas técnicos com o móvel, favor informar o número de lote e data de fabricação, identificados nas bordas de alguns componentes dos móveis, para o rastreamento interno do produto e solução do problema.**

If technical problems happened, please find the lot number and manufacturing date, identified on borders of some furniture's pieces, to internal tracking and problem's solution.

**Dans le cas de problèmes technique avec le meuble, informer le numéro de lot et la date de fabrication, identifié dans le cadre de quelque composant des meubles, permettant a nous identifier le produit et le problème.**

En caso de problemas técnicos, por favor informe el N° del lote y la fecha de fabricación identificada en el borde de algunas de las partes del mueble para la identificación interna del producto y la solución del problema.

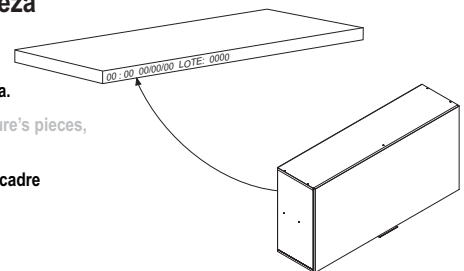

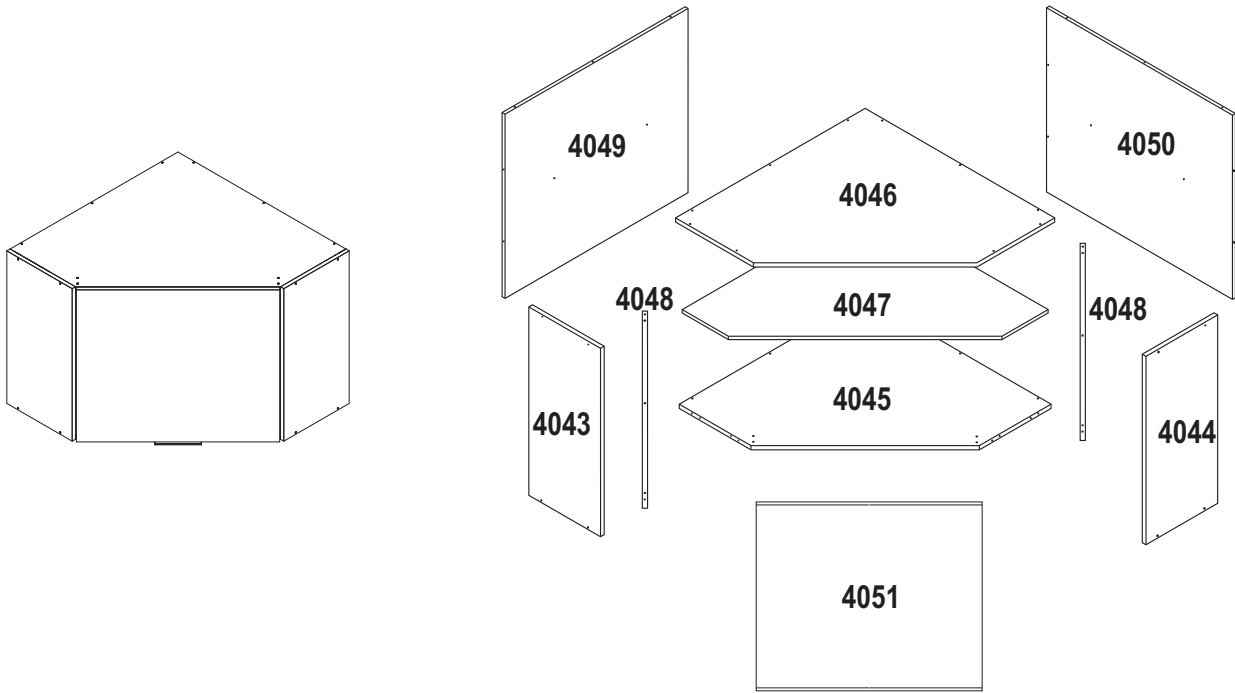

CÓDIGO	DESCRIÇÃO DAS PEÇAS	QTD.	DIMENSÃO = MM
4043	LATERAL DIREITA	01	298X602X15
4044	LATERAL ESQUERDA	01	298X602X15
4045	BASE INFERIOR	01	765X765X15
4046	BASE SUPERIOR	01	765X765X15
4047	PRATELEIRA	01	753X753X15
4048	BATENTE	02	65X572X15
4049	PAINEL TRASEIRO MENOR	01	753X572X12
4050	PAINEL TRASEIRO MAIOR	01	765X572X12
4051	PORTA	01	655X600X15

accessories

acessorios

accessoires

acessórios

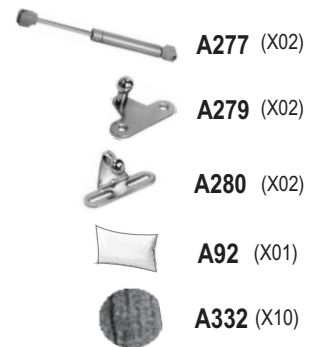
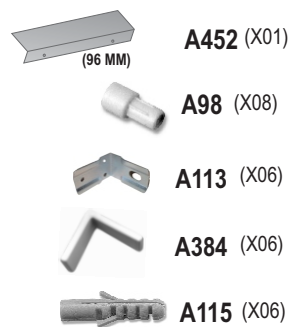
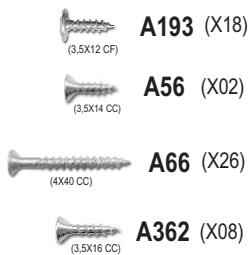

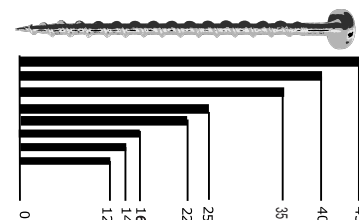
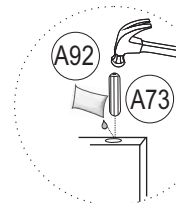
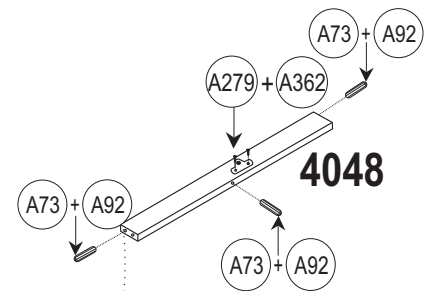
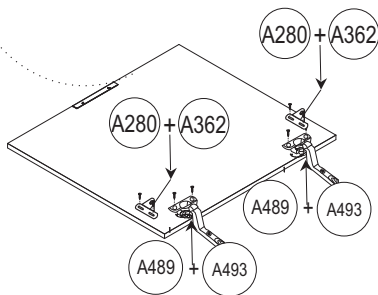
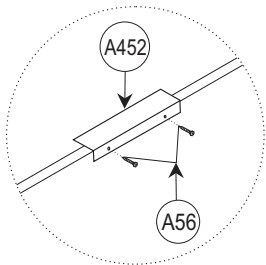
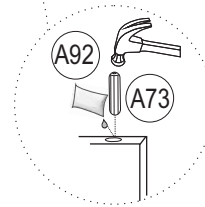
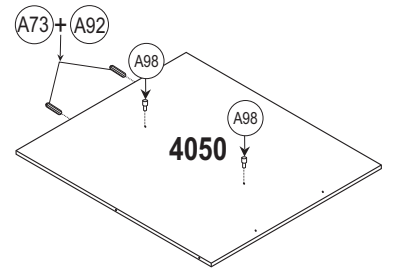
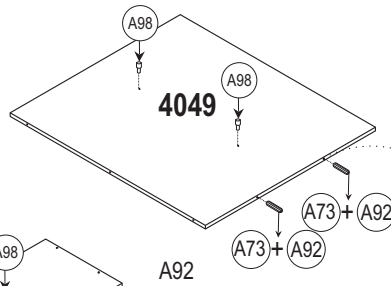
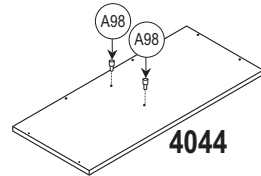
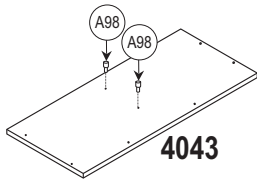
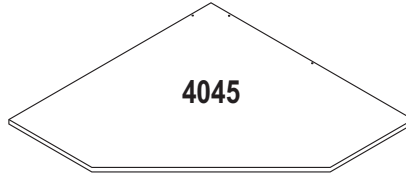
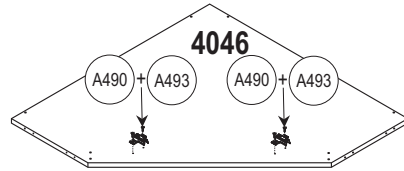

Scale (mm)  
Balanza (mm)  
Échelle (mm)  
Escala (mm)

01

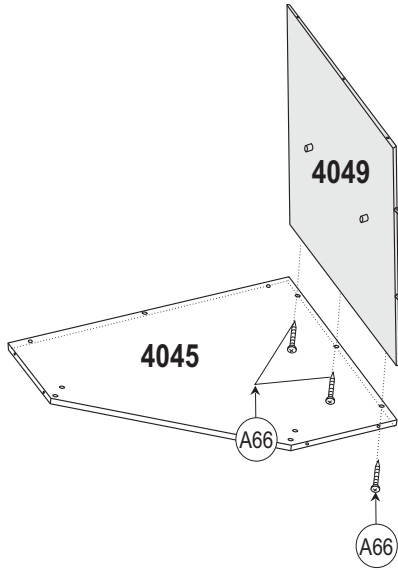

02

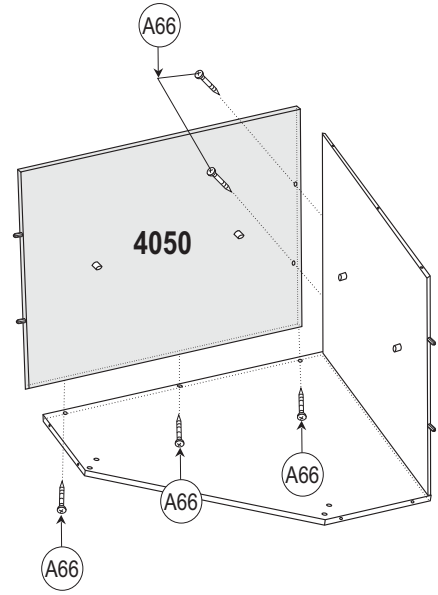

03

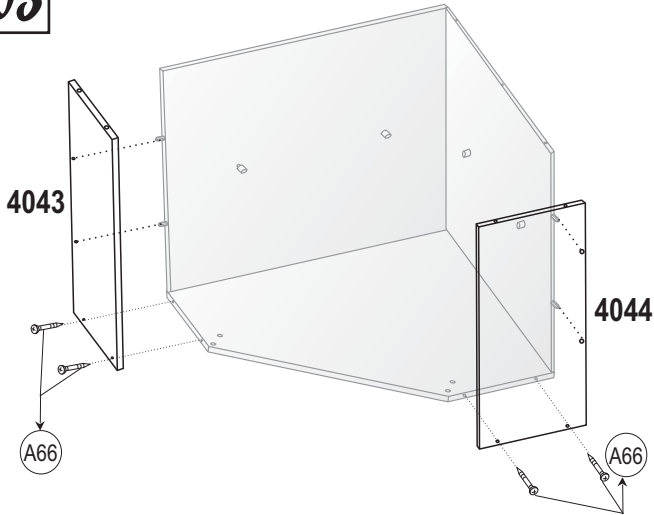

04

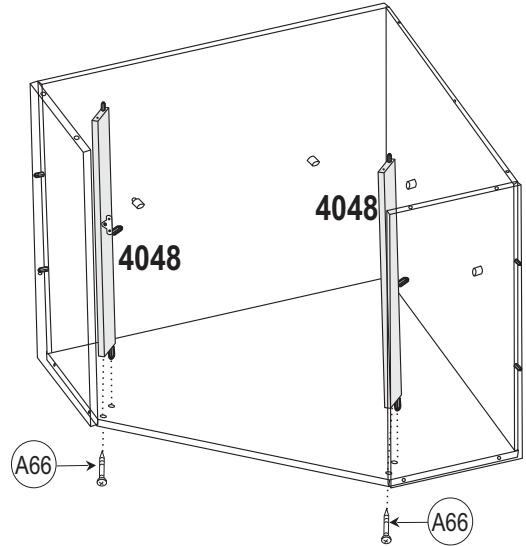

05

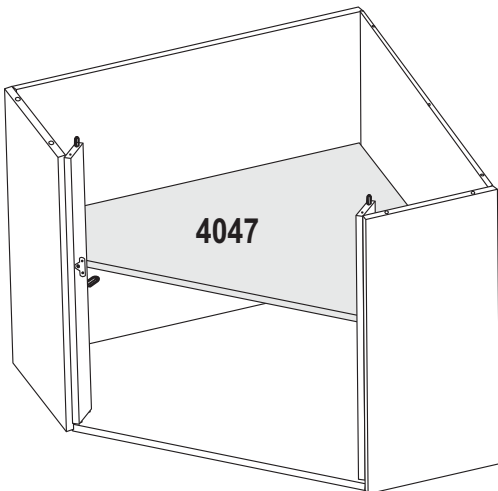

06

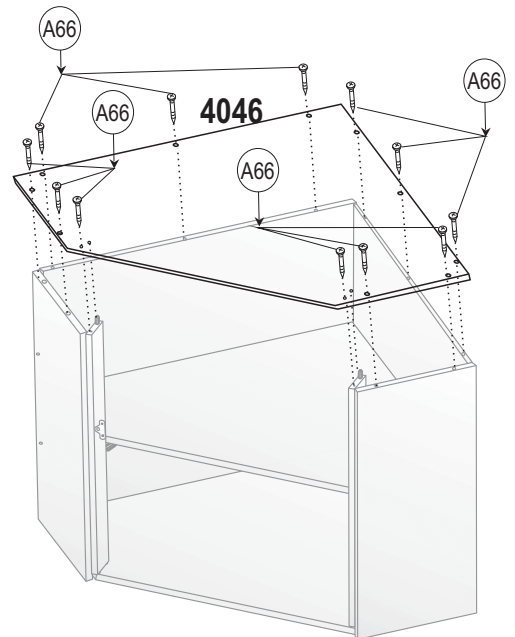

## 07

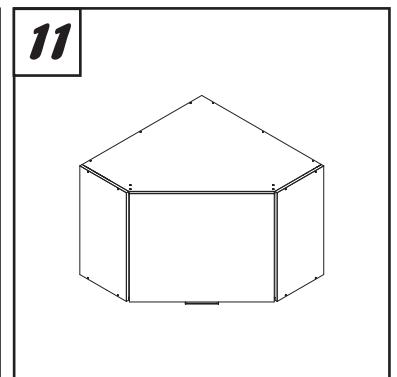
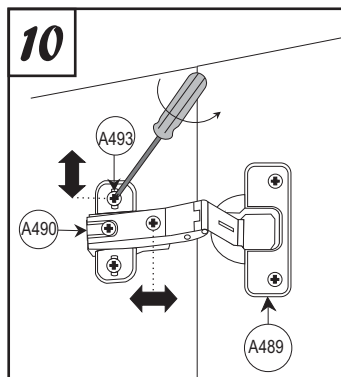
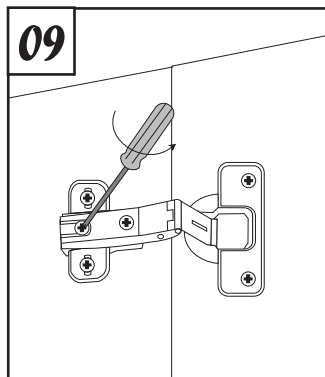
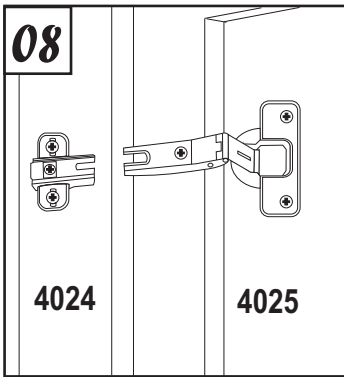
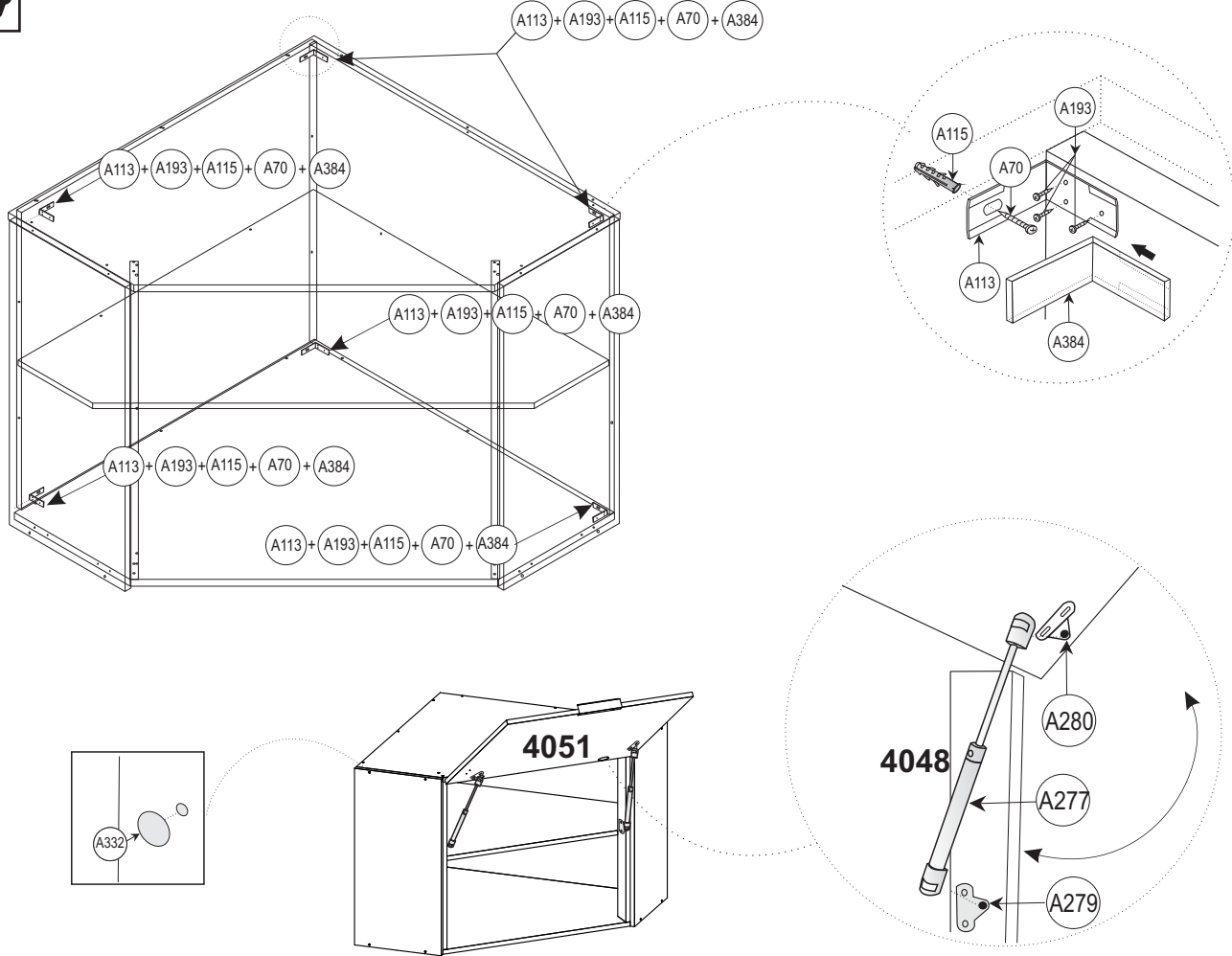

- In order to adjust correctly the door, please observe the picture. In order that the doors stay at the same level the adjustment should be done through the screw A493 from A490 accessory.
- Para ajustar correctamente la puerta, por favor observe la imagen. Para la permanencia de puertas en el mismo nivel el ajuste deberá ser hecho por el tornillo A493 del accesorio de A490.
- Pour ajuster correctement la porte, observez s'il vous plaît l'image. Afin que les portes soient au même niveau l'ajustement devrait être fait par la vis A493 de l'accessoire A490.
- Para o ajuste ideal das portas, observe a foto em destaque. Para que as portas fiquem no mesmo nível, o ajuste deverá ser feito através do parafuso A493 do acessório A490.

### peça    piece    pièce    pieza

**Em caso de problemas técnicos com o móvel, favor informar o número de lote e data de fabricação, identificados nas bordas de alguns componentes dos móveis, para o rastreamento interno do produto e solução do problema.**

If technical problems happened, please find the lot number and manufacturing date, identified on borders of some furniture's pieces, to internal tracking and problem's solution.

**Dans le cas de problèmes technique avec le meuble, informer le numéro de lot et la date de fabrication, identifié dans le cadre de quelque composant des meubles, permettant à nous identifier le produit et le problème.**

En caso de problemas técnicos, por favor informe el N° del lote y la fecha de fabricación identificada en el borde de algunas de las partes del mueble para la identificación interna del producto y la solución del problema.

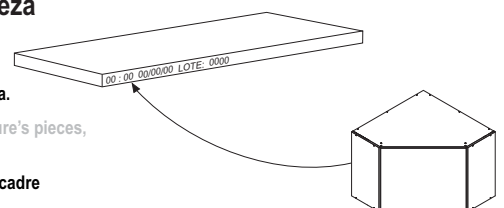



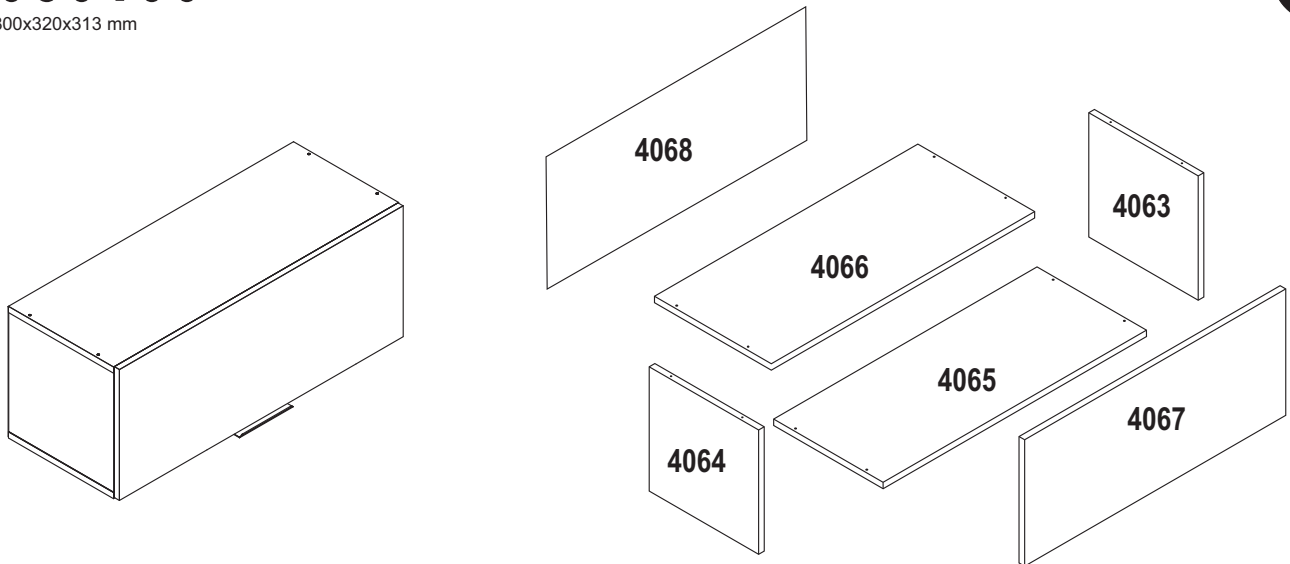

CÓDIGO	DESCRIÇÃO DAS PEÇAS	QTD.	DIMENSÃO = MM
4063	LATERAL DIREITA	01	295X290X15
4064	LATERAL ESQUERDA	01	295X290X15
4065	BASE INFERIOR	01	295X800X15
4066	BASE SUPERIOR	01	295X800X15
4067	PORTA	01	318X796X15
4068	FUNDO TRASEIRO	01	315X796X15

accessories

accesorios

accessoires

acessórios

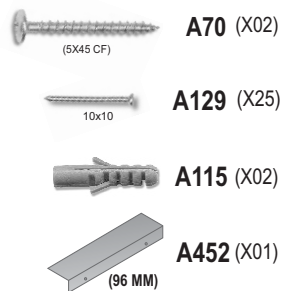
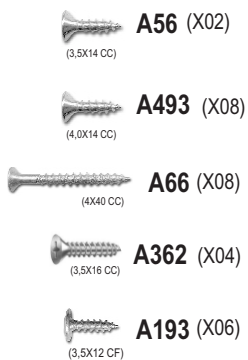

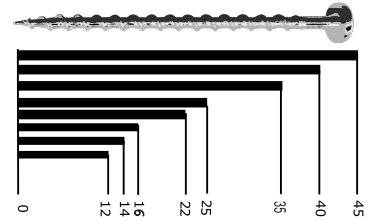
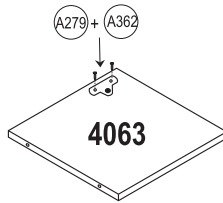
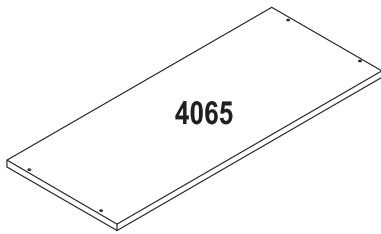
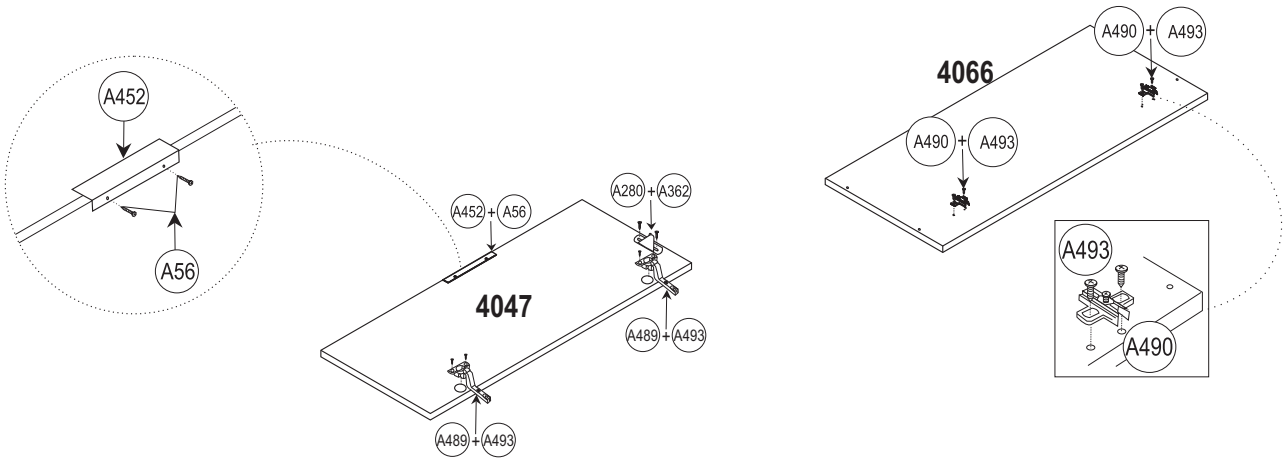

Scale (mm)  
Balanza (mm)  
Échelle (mm)  
Escala (mm)

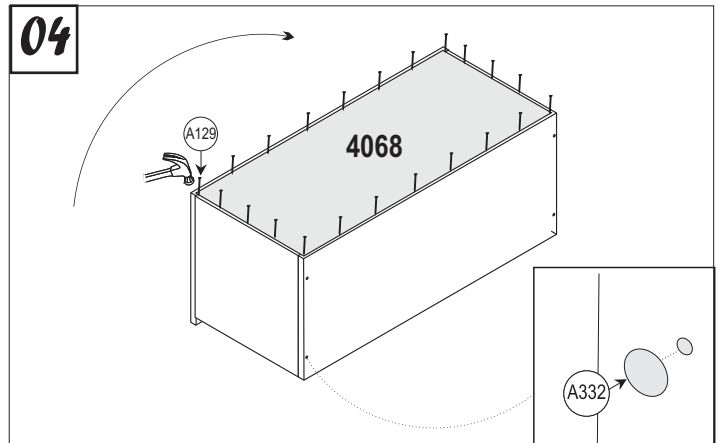
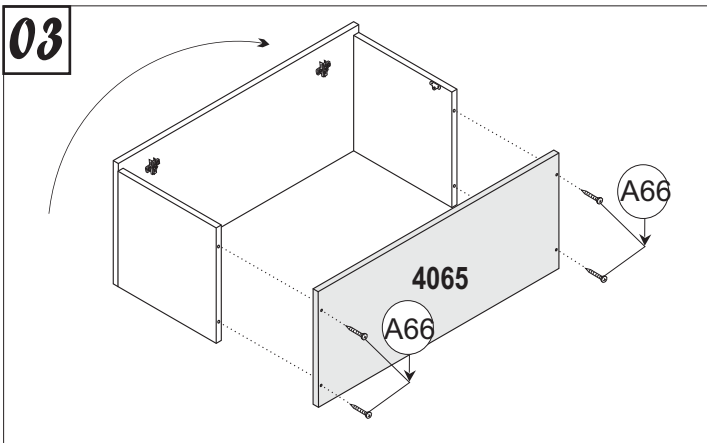
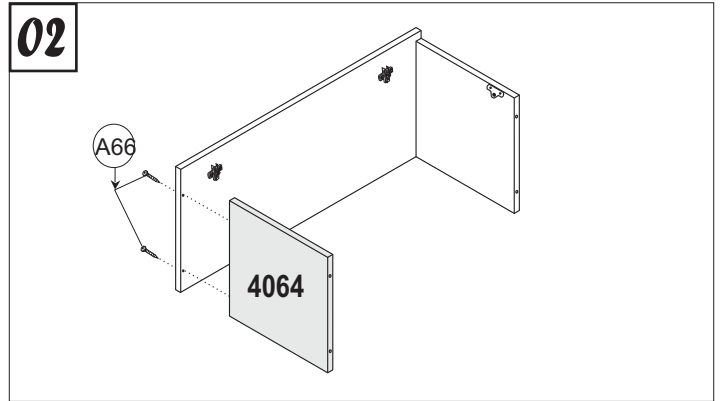
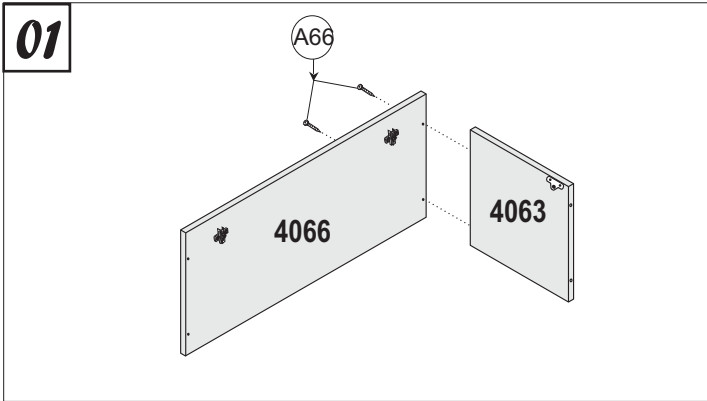

05

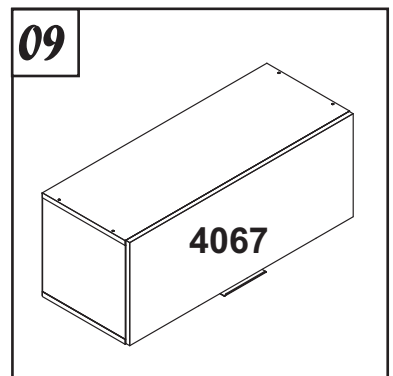
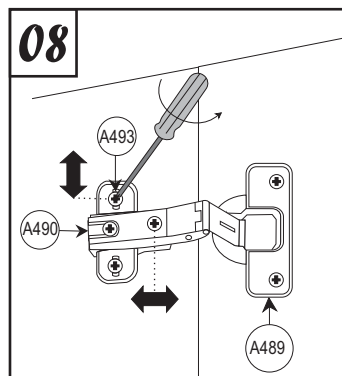
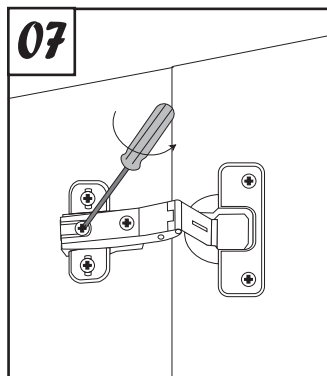
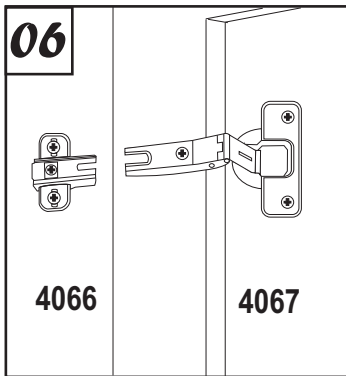
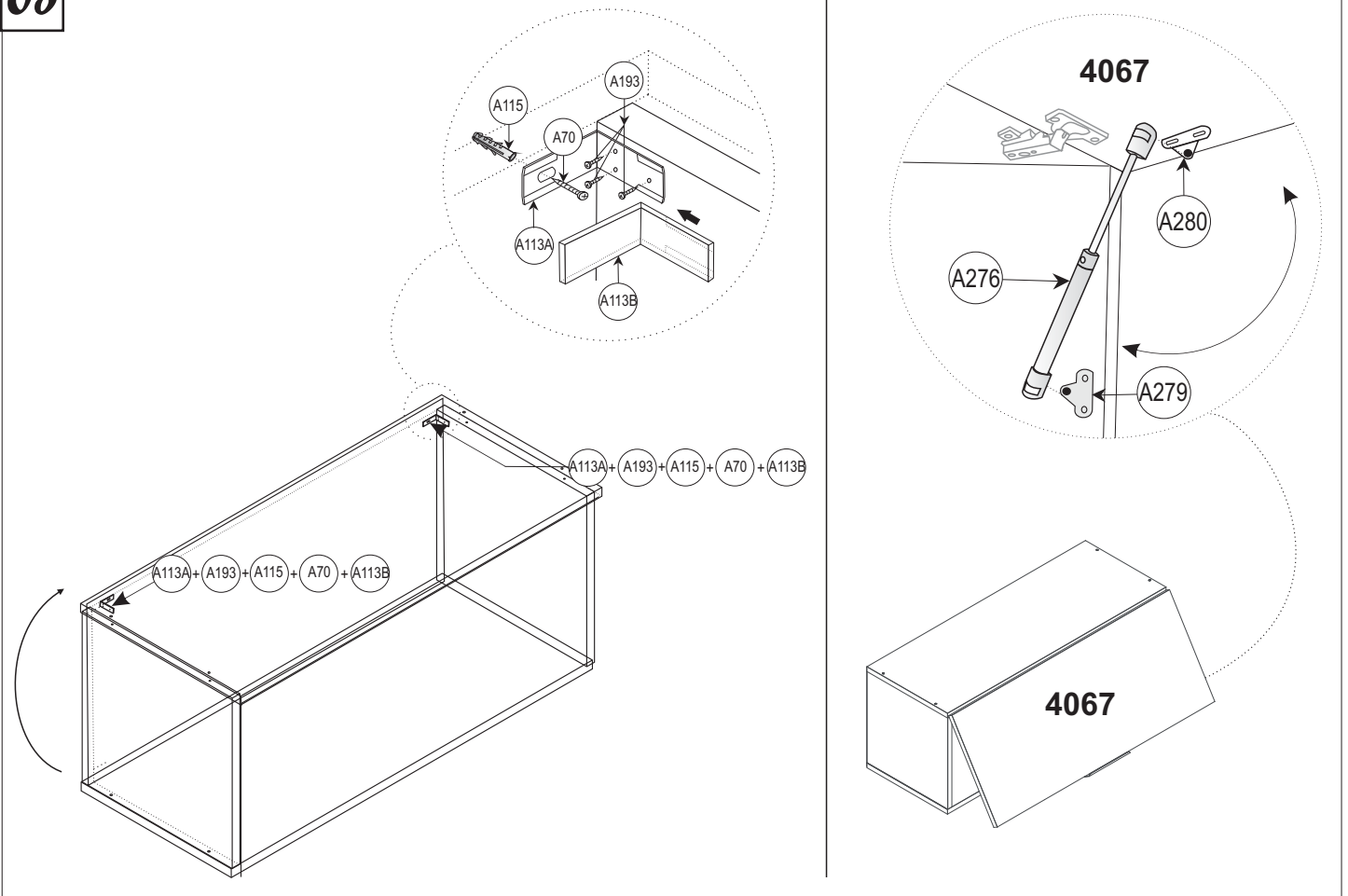

- In order to adjust correctly the door, please observe the picture. In order that the doors stay at the same level the adjustment should be done through the screw A493 from A490 accessory.
- Para ajustar correctamente la puerta, por favor observe la imagen. Para la permanencia de puertas en el mismo nivel el ajuste deberá ser hecho por el tornillo A493 del accesorio de A490.
- Pour ajuster correctement la porte, observez s'il vous plaît l'image. Afin que les portes soit au même niveau l'ajustement devrait être fait par la vis A493 de l'accessoire A490.
- Para o ajuste ideal das portas, observe a foto em destaque. Para que as portas fiquem no mesmo nível, o ajuste deverá ser feito através do parafuso A493 do acessório A490.

peça      piece      pièce      pieza

Em caso de problemas técnicos com o móvel, favor informar o número de lote e data de fabricação, identificados nas bordas de alguns componentes dos móveis, para o rastreamento interno do produto e solução do problema.

If technical problems happened, please find the lot number and manufacturing date, identified on borders of some furniture's pieces, to internal tracking and problem's solution.

Dans le cas de problèmes technique avec le meuble, informer le numéro de lot et la date de fabrication, identifie dans le cadre de quelque composant des meuble, permettant a nous identifier le produit et le problème.

En caso de problemas técnicos, por favor informe el N° del lote y la fecha de fabricación identificada en el borde de algunas de las partes del mueble para la identificación interna del producto y la solución del problema.

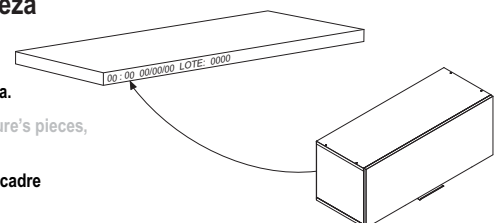

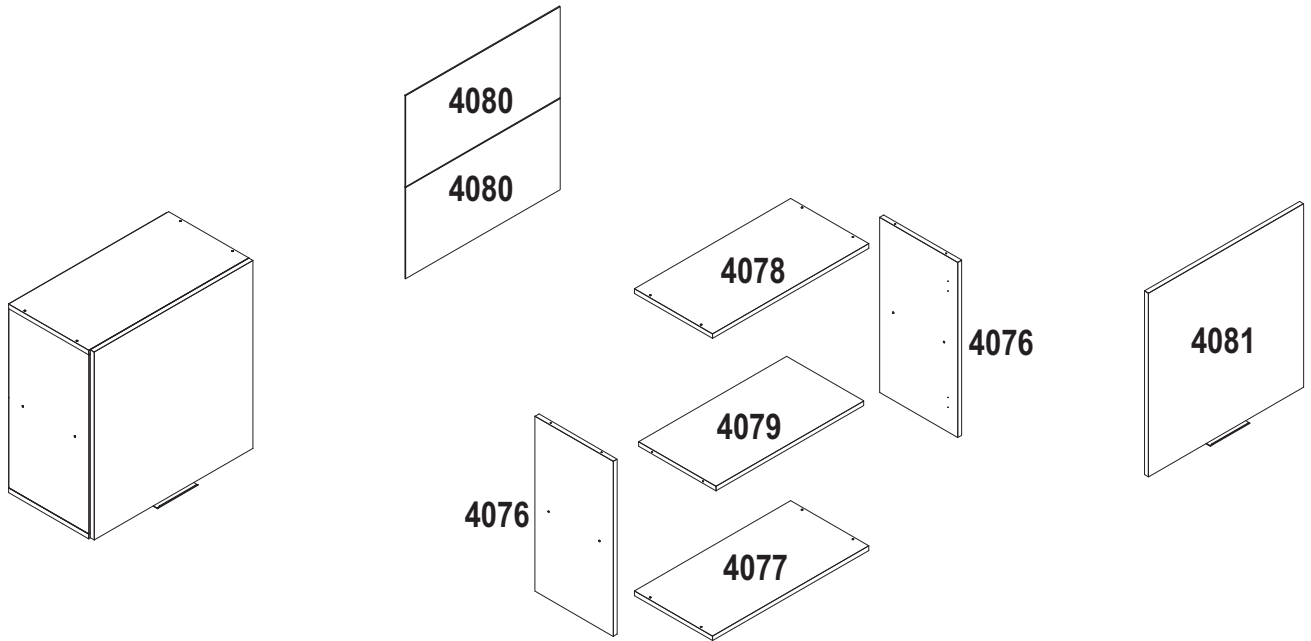

CÓDIGO	DESCRIÇÃO DAS PEÇAS	QTD.	DIMENSÃO = MM
4076	LATERAL	02	295X572X15
4077	BASE INFERIOR	01	295X590X15
4078	BASE SUPERIOR	01	295X590X15
4079	PRATELEIRA	01	292X558X15
4080	FUNDO TRASEIRO	02	298X585X03
4081	PORTA	01	585X600X15

accessories

acessorios

accessoires

acessórios

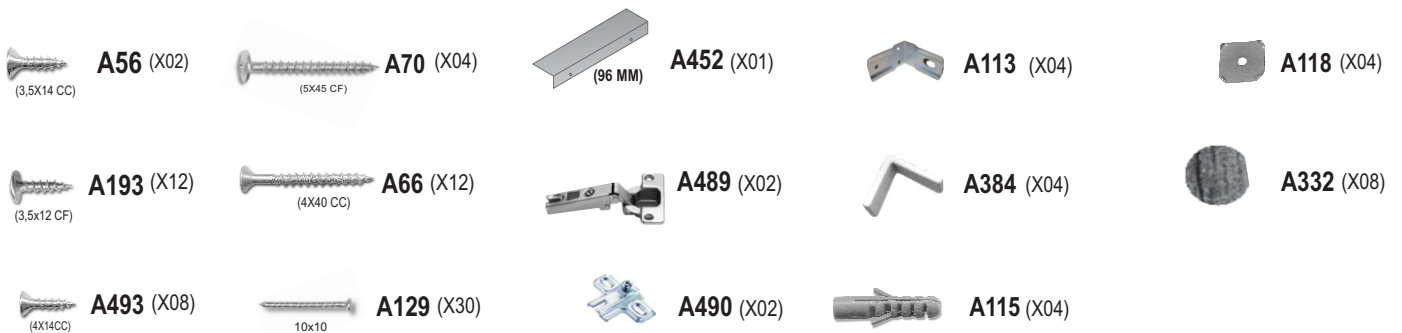

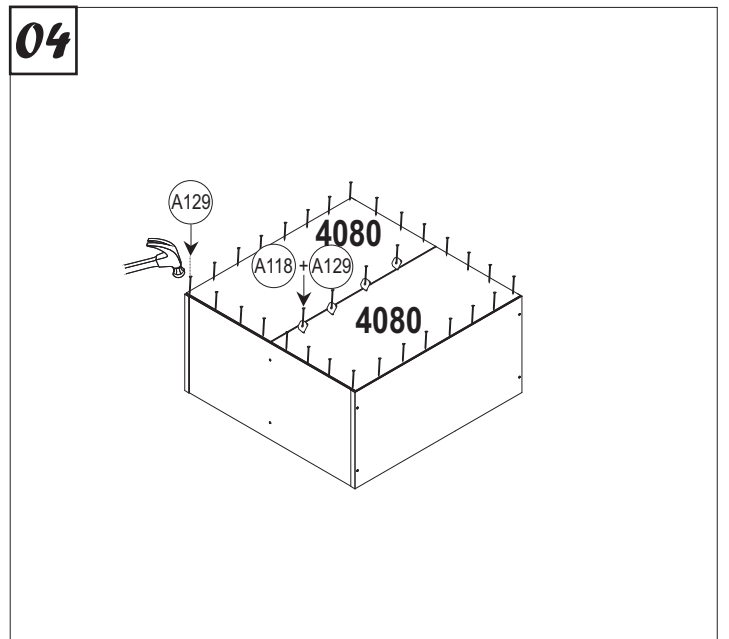
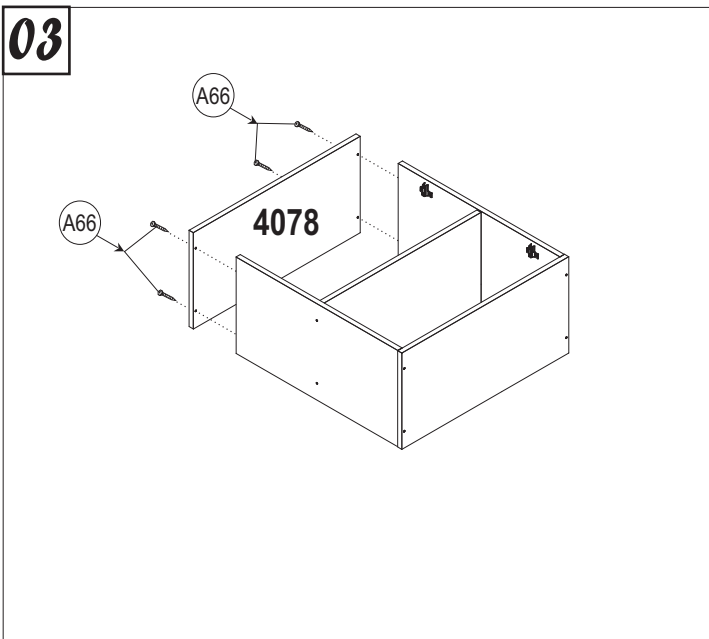
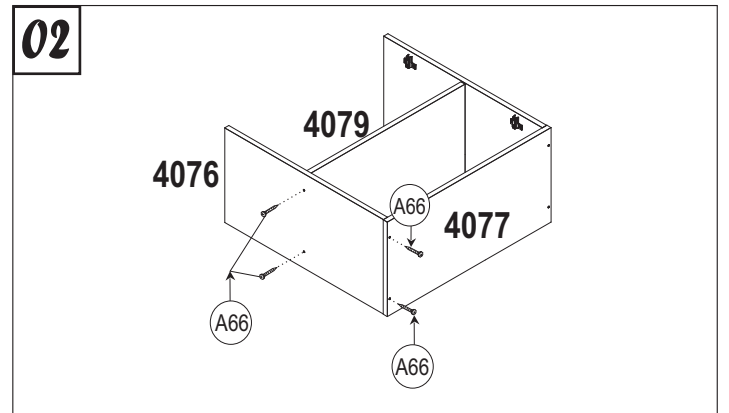
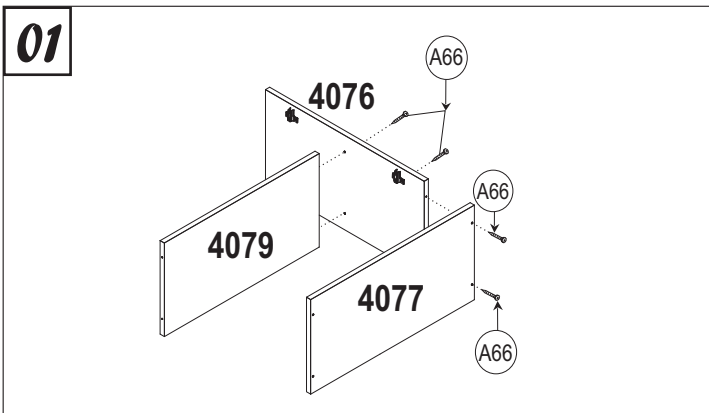
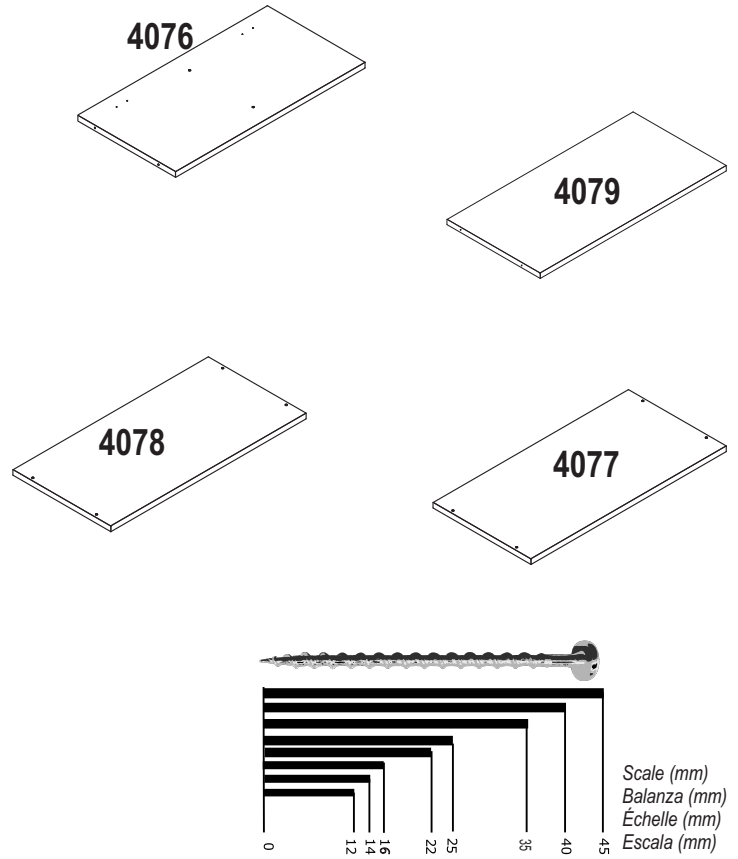
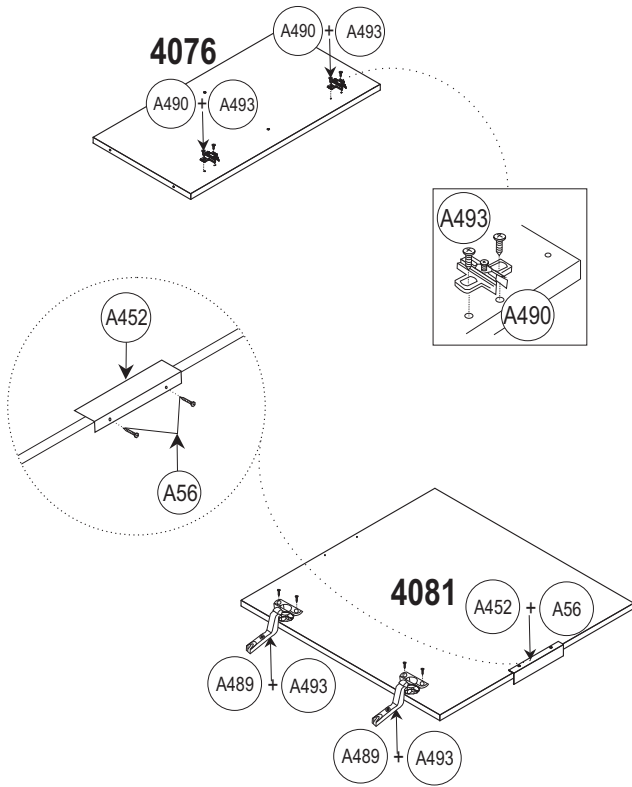

05

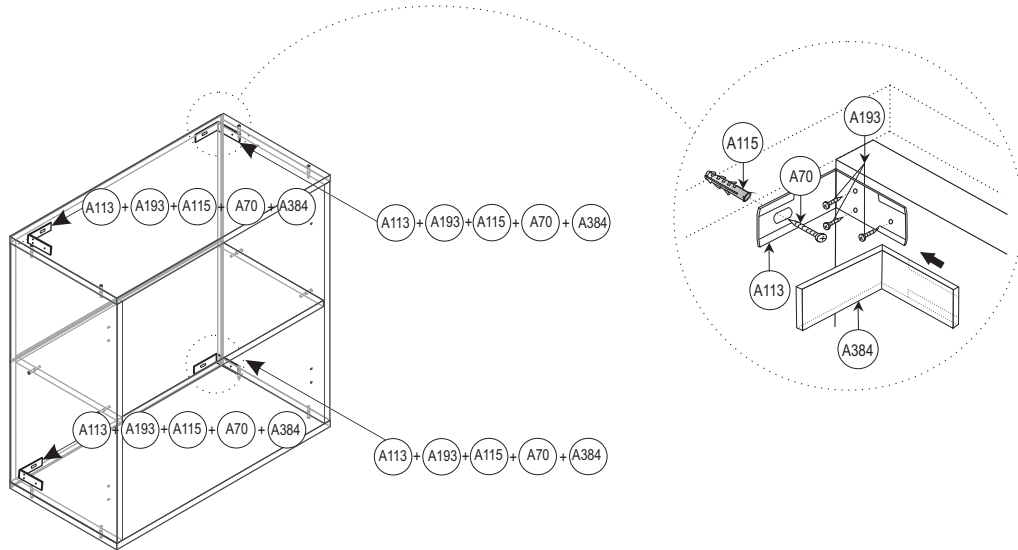

06

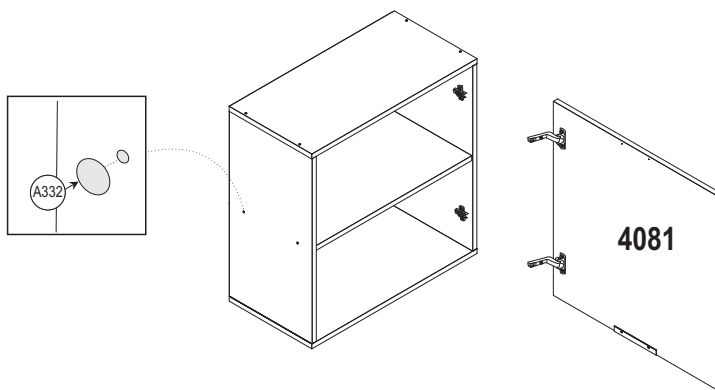

07

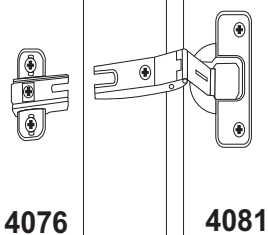

08

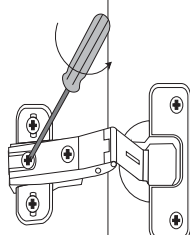

09

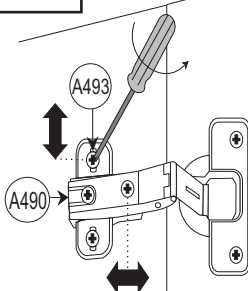

10

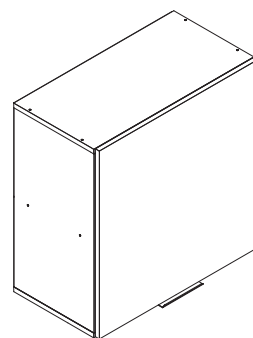

- In order to adjust correctly the door, please observe the picture. In order that the doors stay at the same level the adjustment should be done through the screw A493 from A490 accessory.
- Para ajustar correctamente la puerta, por favor observe la imagen. Para la permanencia de puertas en el mismo nivel el ajuste deberá ser hecho por el tornillo A493 del accesorio de A490.
- Pour ajuster correctement la porte, observez s'il vous plaît l'image. Afin que les portes soit au même niveau l'ajustement devrait être fait par la vis A493 de l'accessoire A490.
- Para o ajuste ideal das portas, observe a foto em destaque. Para que as portas fiquem no mesmo nível, o ajuste deverá ser feito através do parafuso A493 do acessório A490.

peça    piece    pièce    pieza

- Em caso de problemas técnicos com o móvel, favor informar o número de lote e data de fabricação, identificados nas bordas de alguns componentes dos móveis, para o rastreamento interno do produto e solução do problema.
- If technical problems happened, please find the lot number and manufacturing date, identified on borders of some furniture's pieces, to internal tracking and problem's solution.
- Dans le cas de problèmes technique avec le meuble, informer le numéro de lot et la date de fabrication, identifie dans le cadre de quelque composant des meuble, permettant a nous identifier le produit et le problème.
- En caso de problemas técnicos, por favor informe el N° del lote y la fecha de fabricación identificada en el borde de algunas de las partes del mueble para la identificación interna del producto y la solución del problema.

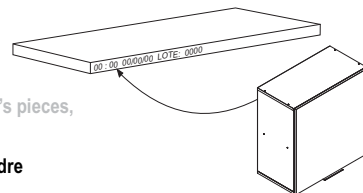

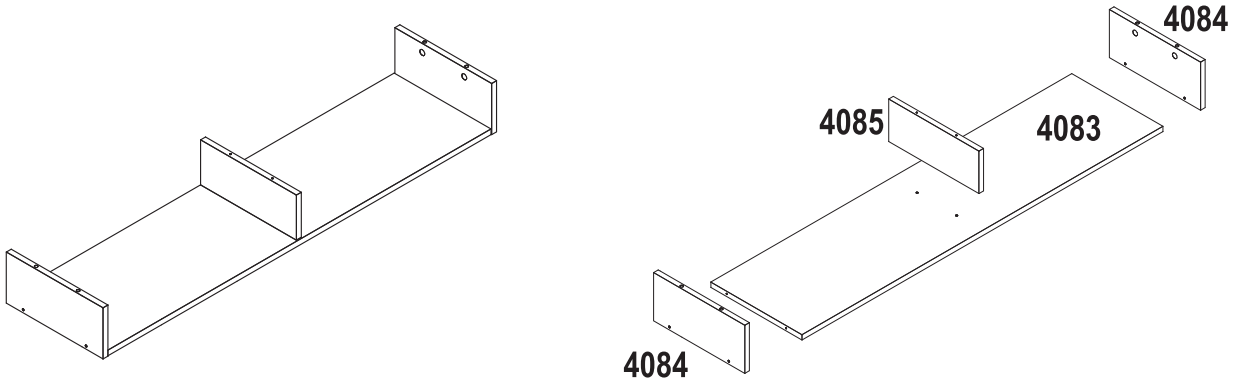

CÓDIGO	DESCRIÇÃO DAS PEÇAS	QTD.	DIMENSÃO = MM
4083	BASE	01	295X1.168X15
4084	LATERAL	02	295X135X15
4085	DIVISÃO	01	292X119X15

accessories    accesorios    accessoires    acessórios

