

**586002-TP2-27F**

**USER'S MANUAL**

**5.8GHz Digital Spread Spectrum  
Cordless Telephone System**



**CORTELCO**

**Copyright**

© 2005, All Rights Reserved.

Reproduction, adaptation, or translation without prior written permission is prohibited, except as allowed under the copyright laws.

Release: September 2005 Rev 1.0

**Disclaimer**

The information contained in this document is subject to change without notice and makes no warranty of any kind with respect to this information. It shall not be liable for any direct, indirect, incidental, consequential, or other damage alleged in connection with the furnishing or use of this information.

Printed in China

To fully enjoy all the benefits of this product, we ask that you review the information contained in this manual

## **Table of Contents**

Important Safety Instructions .....	5
Safety Instructions for Handset Battery Pack .....	6
<b>PART I 586002TP227F FEATURES .....</b>	<b>7</b>
1 Handset and Base Layouts .....	7
2 Getting Started .....	8
<b>PART II CORDLESS PHONE OPERATION .....</b>	<b>9</b>
3 Basic Programming .....	9
Setting Date and Time .....	9
Setting the Alarm .....	9
Auto Talk .....	9
Handset Naming .....	9
Display Language .....	9
Ringer Melody .....	10
Ringer Volume .....	10
4 Making Calls .....	10
5 Answering Calls .....	10
6 Volume Adjustment .....	10
7 Redial .....	10
8 Speakerphone .....	10
9 Using a Headset .....	10
10 Talk Display .....	11
11 Direct Call .....	11
12 Caller ID / Call Waiting ID .....	11
Reviewing Call List .....	11
Dialing from CID .....	11
Deleting CID Records .....	12
Storing CID Records .....	12
Storing a CID Phone Number and then Adding a Name .....	12
13 Phonebook .....	12
Storing Names and Numbers .....	12
Editing Phonebook Entries .....	13
Special Ring .....	13
Storing a Pause .....	13
Dialing from the Phonebook .....	13
Deleting Phonebook Entries .....	13
14 Voicemail / Message Waiting .....	13
15 Page .....	14
16 Intercom .....	14
17 Call Transfer (requires a second Handset) .....	14
18 Conference Call (requires a second Handset) .....	14
19 Tones .....	14
20 Key Lock .....	15
21 Handset Power .....	15

<b>PART III ADVANCED SETTINGS</b> .....	16
22 Advanced Settings Menu .....	16
Reset Handset .....	16
Change Pin (Handset).....	16
Registration (of Handsets) .....	16
Select Base .....	17
Deregister - Handset .....	17
Deregister – Base .....	17
23 Base Settings .....	17
Audio .....	17
Reset Base.....	18
Additional .....	18
Call Barring .....	18
Base Pin.....	18
<b>FCC INFORMATION</b> .....	19
<b>WARRANTY INFORMATION</b> .....	20

## **Important Safety Instructions**

BEFORE USING YOUR TELEPHONE EQUIPMENT, BASIC SAFETY PRECAUTIONS SHOULD ALWAYS BE FOLLOWED TO REDUCE THE RISK OF FIRE, ELECTRIC SHOCK AND INJURY, INCLUDING THE FOLLOWING:

1. Read and understand all instructions.
2. Follow all warnings and instructions marked on the product.
3. Unplug this product from the wall outlet before cleaning. Do not use liquid cleaners or aerosol cleaners. Use a damp cloth for cleaning.
4. Do not use this product near water, for example, near a bath tub, wash bowl, kitchen sink, laundry tub, in a wet basement, or near a swimming pool.
5. Do not place this product on an unstable cart, stand, or table. The product may fall, causing serious damage to the product.
6. Slots and openings in the cabinet and the back or bottom are provided for ventilation. To protect it from overheating, these openings must not be blocked or covered. The openings should never be blocked by placing the product on the bed, sofa, rug, or other similar surface. This product should never be placed near or over a radiator or heat register. This product should not be placed in a built-in installation unless proper ventilation is provided.
7. This product should be operated only from the type of power source indicated on the marking label. If you are not sure of the type of power supply to your home, consult your dealer or local power company.
8. Do not allow anything to rest on the power cord. Do not locate this product where the cord will be damaged by persons walking on it.
9. Do not overload wall outlet extension cords, as this can result in the risk of fire or electric shock.
10. Never push objects of any kind into this product through cabinet slots as they may touch dangerous voltage points or short out parts that could result in a risk of fire or electric shock. Never spill liquid of any kind on this product.
11. To reduce the risk of electric shock, do not disassemble this product. Instead, when some repair work is required, take the unit to a qualified technician. Opening or removing covers may expose you to dangerous voltages or other risks. Incorrect reassembly can cause electric shock when the appliance is subsequently used.
12. Unplug this product from the wall outlet and refer servicing to qualified service personnel under the following conditions:
  - a. When the power supply cord or plug is damaged or frayed.
  - b. If liquid has been spilled into the product.
  - c. If the product has been exposed to rain or water.
  - d. If the product does not operate normally by following the operating instructions. Adjust only those controls that are covered by the operating instructions because improper adjustment of other controls may result in damage and will often require extensive work by a qualified technician to restore the product to normal operation.
  - e. If the product has been dropped or cabinet has been damaged.
  - f. If the product exhibits a distinct change in performance.
13. Avoid using a telephone (other than a cordless type) during an electrical storm. There may be a remote risk of electrical shock from lightning.
14. Do not use the telephone to report a gas leak in the vicinity of the leak.
15. This power unit is intended to be correctly oriented in a vertical or floor mount position.
16. Plug the power adaptor into an electrical outlet that is near the equipment and easily accessible.

**SAVE THESE INSTRUCTIONS**

## **Safety Instructions for Handset Battery Pack**

### **CAUTION:**

There is a danger of explosion if battery is incorrectly replaced. Use only an approved battery pack in the handset of your Cordless Telephone. To reduce the risk of fire or injury, always do the following when replacing, discarding, or charging battery. When handling the batteries, be careful not to short the battery with conducting materials such as rings, bracelets, and keys. The Battery or conducting material may overheat and cause burns. Use only the following type and size of battery pack:

### **FOR HANDSET UNIT:**

GP60AAAH3BMXZ 3.6V 600mAh GPI INTERNATIONAL LIMITED



CONTAINS NICKEL-METAL HYDRIDE BATTERY. BATTERY MUST BE RECYCLED OR DISPOSED OF PROPERLY

1. Do not dispose of the battery in a fire. The cell may explode. Check with local codes for possible special disposal instructions.
2. Do not open or mutilate the battery. Released electrolyte is corrosive and may cause damage to the eyes or skin. It may be toxic if swallowed.
3. Exercise care in handling batteries in order not to short the battery with conducting materials such as rings, bracelets and keys. The battery or conductor may overheat and cause burns.
4. Charge the batteries provided with or identified for use with this product only in accordance with the instructions and limitations specified in this manual.
5. Observe proper polarity orientation between the battery(ies) and battery charger.
6. Do not mix old and new batteries in this product.
7. Do not mix batteries of different sizes or from different manufacturers in this product.

### **SAVE THESE INSTRUCTIONS**

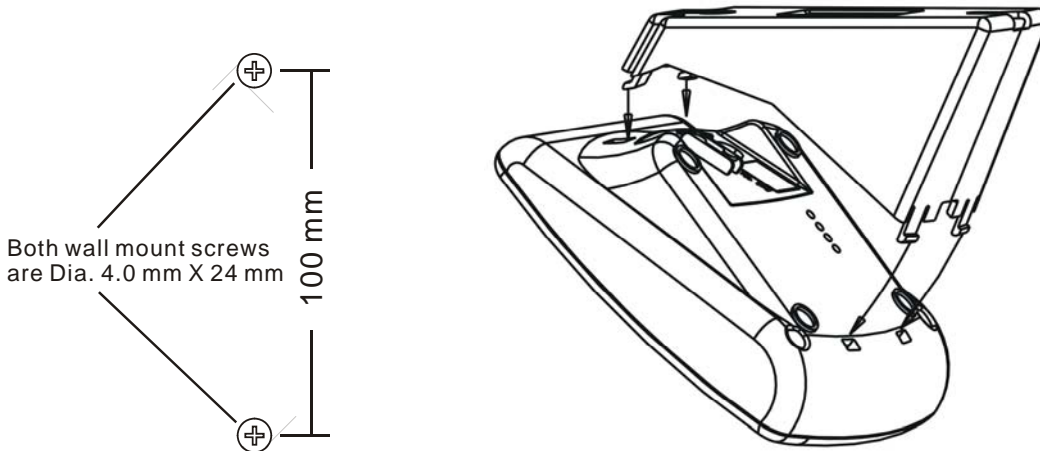

Connecting the wall mount bracket (See "Getting Started" on page 8)

## PART I 586002TP227F FEATURES

Caller ID (subscription required)  
 Call Waiting (subscription required)  
 Illuminated Handset Display  
 Clock  
 Call Timer  
 40 Name & Number Phonebook  
 6 Handset Capability

5 Number Redial  
 Base to Handset Page  
 Auto Answer out of Cradle  
 2-Way Intercom (requires 2 Handsets)  
 Mute  
 Headset Jack (2.5 mm)  
 Tone / Pulse Dialing

### 1 Handset and Base Layouts

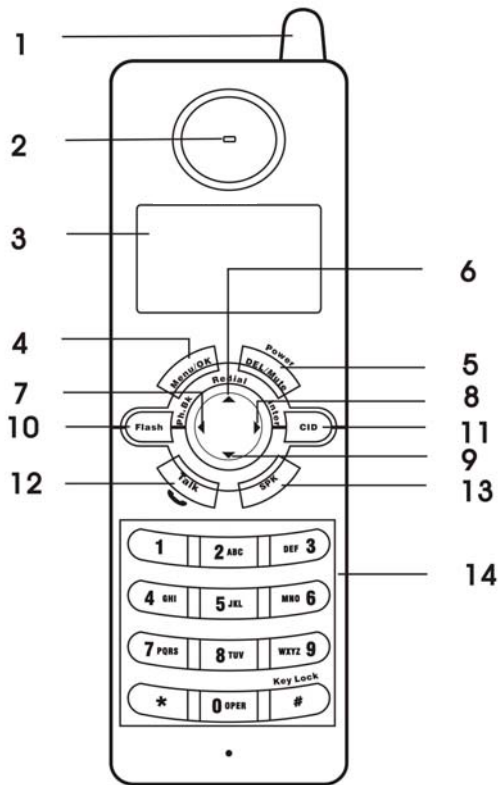

#### Layout of Handset Function Keys

- 1. Antenna
- 2. Earpiece
- 3. Display (LCD)
- 4. Menu / OK
- 5. Delete / Mute (Power)
- 6. Redial / Volume Up (▲)
- 7. Phone Book (◀)

- 8. Intercom (▶)
- 9. Volume Down (▼)
- 10. Flash
- 11. Caller ID
- 12. Talk / Hang Up
- 13. Speakerphone
- 14. Dialpad

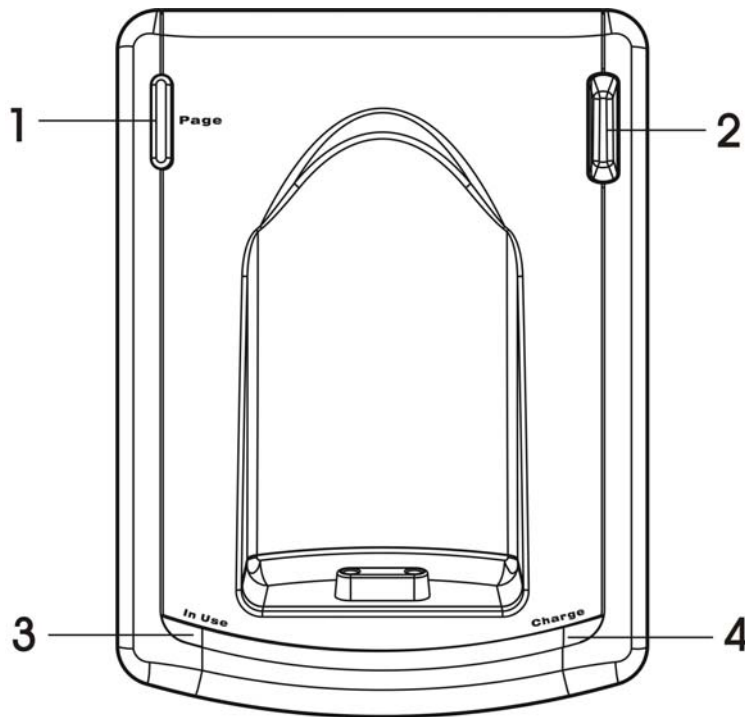

Layout of Base Functions

1. Page
2. Antenna
3. In Use/Message Waiting
4. Charge

## 2 Getting Started

### Install and Charge the Battery Pack

1. Open the battery cover by gently pressing down on the top of the cover while sliding it down.
2. Plug the Battery Pack connector into the Handset socket, and then place the battery pack and wires in the compartment. The printing on the pack should be upright and facing you, with the battery wires coming from the upper right edge of the battery pack.
3. Tuck the wires between the right side of the pack and the wall of the compartment. Replace the battery cover by lining up the four tabs with the corresponding slots, and sliding it up until it locks into place.
4. Attach the belt clip, if desired. If you are wall mounting the Base, connect the DC power cord and telephone line cord to the Base, and then attach the wall mount bracket. Run the two cords through the rectangular hole located on the back of the bracket, or through the channel located on the bottom of the bracket.
5. Connect the power adapter to the Base and a live outlet. Make sure a switch does not control the outlet. The outlet should be near the Base Unit, and easily accessible. DO NOT connect the telephone line cord to your live telephone jack until the Handset is fully charged.
6. Place the Handset in the Base cradle. The Handset and Base communicate with each other automatically. This is the Registration process, and it may take up to 60 seconds.
7. Allow the Handset to charge for a day for the first time charging. The CHARGE indicator on the Base will glow while the Handset is charging.



## **PART II CORDLESS PHONE OPERATION**

Note: If you do not press any keys for 60 seconds, your Handset will exit programming mode and return to the idle display.

### **3 Basic Programming**

#### **Setting Date and Time**

Press Menu/OK, and then press ▲ or ▼ until you see >Set Clock.

Press Menu/OK again. Now, use the dialpad to enter the Date, Month, and Year. If you need to correct any digits, press ◀ or ▶ to move the cursor backward or forward.

Press ▼ to place the cursor on the next line. Now, enter the hour, and then the minute. Press Flash to choose AM or PM.

Press Menu/OK to confirm. Press DEL/Mute to return to the idle screen.

#### **Setting the Alarm**

NOTE: The date and time must be set in order to use the alarm feature.

Press Menu/OK, and then press ▲ or ▼ until you see >Set Alarm.

Press Menu/OK again. Press ▲ or ▼ to turn the alarm >On (or >Off).

Press Menu/OK again. Set the desired alarm time. Press Flash to choose AM or PM.

Press Menu/OK to confirm.

Press DEL/Mute to return to the idle screen. You will see 'A' on the bottom line of the screen, indicating the alarm has been set.

When the alarm sounds, press any key to turn it off.

#### **Auto Talk**

With Auto Talk 'On', your Handset will answer the call when you pick it up from its cradle.

Press Menu/OK, and then press ▲ or ▼ until you see >Auto Talk.

Press Menu/OK again. Press ▲ or ▼ to turn Auto Talk >On (or >Off).

Press Menu/OK to confirm. Press DEL/Mute to return to the idle screen.

#### **Handset Naming**

Press Menu/OK, and then press ▲ or ▼ until you see >Display.

Press Menu/OK again. You will see >Handset Name.

Press Menu/OK again. Use the dialpad to enter the desired name. Use ◀ and ▶ to move the cursor left and right.

Use DEL/Mute to erase letters.

When finished, press Menu/OK to save the name.

Press DEL/Mute twice to return to the idle screen.

#### **Display Language**

(preset to English)

Press Menu/OK, and then press ▲ or ▼ until you see >Display.

Press Menu/OK again. Press ▲ or ▼ until you see >Select Language.

Press Menu/OK again, and then press ▲ or ▼ to select the desired language.

Press Menu/OK to confirm. Press DEL/Mute twice to return to the idle screen.

## Ringer Melody

Press Menu/OK, and then press ▲ or ▼ until you see >Audio Settings.  
Press Menu/OK again. Press ▲ or ▼ until you see >Ringer Melodies.  
Press Menu/OK again. Press ▲ or ▼ to choose from:

External Melody (outside calls)  
Internal Melody (intercom calls)  
Paging Melody  
Alarm Melody

Press Menu/OK. Press ▲ or ▼ to select one of ten ringer melodies  
Press Menu/OK to confirm your selection.  
Press DEL/Mute 3 times to return to the idle screen.

## Ringer Volume

Press Menu/OK, and then press ▲ or ▼ until you see >Audio Settings.  
Press Menu/OK again. You will see >Ringer Volume.  
Press Menu/OK again. Press ▲ or ▼ to raise or lower the ringer volume. There are 6 levels, plus Ringer OFF.  
Press Menu/OK to confirm your choice.  
Press DEL/Mute twice to return to the idle screen.

## 4 Making Calls

Press Talk, listen for a dial tone, and then dial the number; OR  
Enter the phone number first, and then press Talk.

## 5 Answering Calls

When the phone rings, press any key except DEL/Mute, to answer the call; OR  
With Auto Talk set to ON, pick the Handset up from its cradle to answer the call.

## 6 Volume Adjustment

While on an active call, press ▲ to raise or ▼ to lower the earpiece, speakerphone or headset volume. To mute the microphone, press DEL/Mute. Press DEL/Mute again to return to the two-way conversation.

## 7 Redial

With the Handset in idle mode, press ▲ to review the last 5 numbers dialed. With the desired number displayed, press Talk to make your call.

## 8 Speakerphone

Press SPK to use the Handset Speakerphone. Press SPK again to return to the earpiece.  
Press Talk to end your call.

## 9 Using a Headset

Your cordless Handset is equipped with a 2.5 mm Headset Jack for use with an optional accessory headset.

Once you have a compatible Headset, locate the headset jack on the side of the Handset. First, remove the protective rubber cover. Plug the headset cord into the jack. Do not force the connection.

When a Headset is connected, the microphone on the Handset is muted to limit the effect of background noise.

Your cordless Handset is also equipped with a Belt Clip. Align the pins located on the inside edge of the clip with the notches on the sides of the Handset. The belt clip should snap securely into place.

## 10 Talk Display

After you make a call, the Handset can either continue to display the phone number you dialed, or it can display a call timer to help you keep track of the call duration. The Handset is preset to display the timer. If you want to reprogram this option, from the idle mode:

Press Menu/OK, and then press ▲ or ▼ until you see >Display.

Press Menu/OK again. Press ▲ or ▼ until you see >Talk Display.

Press Menu/OK again. Press ▲ or ▼ to choose >Time or >Number, and then press Menu/OK to confirm.

Press DEL/Mute twice to return to the idle screen.

## 11 Direct Call

This feature allows you to program a phone number, which will automatically be dialed each time you press Talk or SPK to initiate a call. To program Direct Call:

Press Menu/OK, and then press ▲ or ▼ until you see >Direct Call.

Press Menu/OK again. Enter the phone number. If you make a mistake, press DEL/Mute to backspace.

When finished, press Menu/OK. You will see >Save. Press Menu/OK to confirm.

You will now see Direct On/Off? >On. Press Menu/OK to confirm.

Press DEL/Mute to return to the idle screen.

NOTE: When you use Direct Call, you cannot enter additional digits after the call has been placed.

**WARNING: EMERGENCY NUMBERS SUCH AS 911 WILL NOT WORK WHEN DIRECT CALL IS ENABLED.**

WARNING: When you turn Direct Call on, your programmed number will be dialed each time you press Talk or SPK.

To turn this feature off, follow the above steps. When you see Direct On/Off?, use ▼ to scroll to >Off, and then press Menu/OK to confirm.

Press DEL/Mute to return to the idle screen.

## 12 Caller ID / Call Waiting ID

Your Handset is compatible with Caller ID and Call Waiting ID services, available from your local telephone service provider. There are fees associated with these services. Contact your service provider for details.

### Reviewing Call List

Your Handset stores 20 Caller ID / Call Waiting records. Once CID memory is full, the oldest record will be automatically deleted when a new record is stored. To review CID records:

With the Handset in idle mode, press CID.

Press ▲ or ▼ to scroll through the stored CID records.

When finished, press DEL/Mute to return to the idle screen.

A previously reviewed CID record will display a check mark to the right of the caller's name.

### Dialing from CID

With the desired CID record displayed, press Talk.

If the displayed CID record is not in the correct format for dialing, press # repeatedly to view the other dialing format options (7,8,10 and 11 digit dialing formats). With the correct format displayed, press Talk to dial.

### **Deleting CID Records**

With the desired CID record displayed, press Menu/OK.

Press ▼ until you see >Delete Entry.

Press Menu/OK again. You will see Delete Entry >Yes.

Press Menu/OK again to confirm. Otherwise, press ▼ so that Delete Entry >No is displayed, and then press Menu/OK to confirm.

When finished, press DEL/Mute to return to the idle screen.

NOTE: You can also delete the entire CID list at one time. Follow the above instructions; however, select >Delete List instead.

### **Storing CID Records**

With the desired CID record displayed, press Menu/OK.

You will see >Copy to Phb. Press Menu/OK again.

You can now edit the Name and Number. See the PHONEBOOK section for details on editing.

Once you are satisfied with the Name and Number, press Menu/OK. You can now assign a Special Ring for this number. Use ▲ or ▼ to make your Special Ring selection, and then press Menu/OK.

You will see >Save. Press Menu/OK again to confirm. Otherwise, use ▼ to scroll down to >Go Back, and then press Menu/OK to return to the previous menu.

When finished, press DEL/Mute to return to the idle screen.

### **Storing a CID Phone Number and then Adding a Name**

With the desired CID record displayed, press Menu/OK.

Scroll to >Use Number, and then press Menu/OK again.

Only the phone number is displayed. Press Menu/OK.

You will see >Store to Phb. Press Menu/OK again.

You can now enter the desired name using the dialpad, and then press Menu/OK.

The cursor now drops to the phone number line. Edit the number, if necessary.

Once you are satisfied with the Name and Number, press Menu/OK. You can now assign a Special Ring for this number. Use ▲ or ▼ to make your Special Ring selection, and then press Menu/OK.

You will see >Save. Press Menu/OK again to confirm. Otherwise, use ▼ to scroll down to >Go Back, and then press Menu/OK to return to the previous menu.

When finished, press DEL/Mute to return to the idle screen.

## **13 Phonebook**

You can store 40 Names and Numbers in your Handset Phonebook.

### **Storing Names and Numbers**

In the idle mode, enter the number you wish to store, and then press Menu/OK.

You will see >Store to Phb. Press Menu/OK again.

Use the dialpad to enter the desired Name. Press ► to create a space. Press ◀ to backspace. NOTE: If consecutive letters of the name are located on the same key, you will need to use ► between them.

When you are finished entering the Name, press Menu/OK to confirm. The cursor will move to the Phone Number line. Press Menu/OK again to confirm.

Now, follow the instructions in SPECIAL RING below.

## Editing Phonebook Entries

In the idle mode, press ◀ to access the Phonebook.  
Press ▲ or ▼ to find the desired Phonebook entry.  
Press Menu/OK. You will see >Edit Entry. Press Menu/OK again.  
Use DEL/Mute to delete letters; use ◀ & ▶ to move the cursor back & forth.

NOTE: If consecutive letters of the name are located on the same key, you will need to use ▶ between them.

Press Menu/OK. Now, edit the phone number. Press Menu/OK to confirm.  
Now, follow the instructions in SPECIAL RING below.

## Special Ring

Do you want the Handset to play a different ring when a specific person calls (when incoming Caller ID matches the Phonebook entry)? If so, use ▲ or ▼ to select a Special Ring, and then press Menu/OK to confirm.  
You will see >Save. Press Menu/OK to confirm; otherwise, press ▼ to scroll to >Go Back, and then press Menu/OK to confirm.  
When finished, press and hold DEL/Mute to return to the idle screen.

## Storing a Pause

When you program a name and number in the Phonebook, you can add a 3 second PAUSE in the dialing string. For example, if your phone system requires you to dial '9' to access an outside line, you would program your numbers as follows:

9 PAUSE 555-1212

To add a pause to the dialing sequence:

In the idle mode, begin entering the phone number. At the point where a Pause is required, press Menu/OK.  
Press ▼ until you see >Pause. Press Menu/OK again.  
You will see a P in the dialing sequence, representing the Pause.  
Continue entering the phone number, and then the name, following the instructions in STORING NAMES AND NUMBERS.

## Dialing from the Phonebook

In the idle mode, press ◀ to access the Phonebook.  
Press ▲ or ▼ to find the desired Phonebook entry.  
With the desired entry displayed, press Talk.

## Deleting Phonebook Entries

In the idle mode, press ◀ to access the Phonebook.  
Press ▲ or ▼ to find the desired Phonebook entry.  
Press Menu/OK, and then use ▼ to select >Delete Entry.  
Press Menu/OK again. You will see Delete Entry?  
Press ▲ or ▼ to select >Yes or >No. Press Menu/OK to confirm.  
When finished, press DEL/Mute to return to the idle screen.

## 14 Voicemail / Message Waiting

In conjunction with voicemail service through your local telephone service provider (subscription required), your phone can alert you to new voicemail messages by providing an envelope icon on the display. NOTE: most, but not all

service providers can provide this notification service. There are fees associated with this feature. Contact your service provider for details.

After receiving a 'new message' signal from your service provider, the envelope icon will appear, alerting you that you have new message(s). In addition, the blue ring around the earpiece will flash, as well as the In Use indicator on the Base.

Once you have reviewed all new voicemail messages, the indicators will turn off.

## 15 Page

To locate a Handset, press Page on the Base. Each registered Handset will 'ring' for approximately 30 seconds. To end the page, press Page again at the Base, or press Talk on the Handset.

## 16 Intercom

To talk to another registered Handset, from the idle mode, press ► .

Press ▲ or ▼ to select the destination Handset, and then press Menu/OK to confirm.

When the destination Handset rings, press any key except DEL/Mute to answer.

## 17 Call Transfer (requires a second Handset)

While on an active call, press ► . Your call is automatically placed on Hold.

Press ▲ or ▼ to select the destination Handset, and then press Menu/OK to confirm.

When the destination Handset presses Talk to answer, the person initiating the transfer can announce who is on the line, and then press Talk to hang up. The destination Handset is now connected to the outside call. If the destination Handset hangs up first, the initiating Handset will be reconnected with the outside call.

## 18 Conference Call (requires a second Handset)

This process is similar to a call transfer. While on an active call, press ► . Your call is automatically placed on Hold.

Press ▲ or ▼ to select the destination Handset, and then press Menu/OK to confirm. When the destination Handset presses Talk to answer, the person initiating the transfer can announce who is on the line, and then presses Flash to create a 3-way conference. Both Handsets are now connected to the outside call. If either Handset hangs up, the remaining Handset can continue with the outside call.

When the second Handset enters or leaves the conference call, an alert tone is heard through the earpiece.

## 19 Tones

Your Handset makes various sounds for various reasons, for example:

KEY – the tone you hear when you press a key

CONFIRMATION – the tone you hear when you confirm a setting

WARNING – the tone you hear when the battery pack needs recharging

CALL WAITING – the tone you hear while on a call and Call Waiting ID is received

OUT OF RANGE – the tone you hear when the Handset is taken out of range from the Base.

You can turn each of the above tones On or Off. From the idle mode:

Press Menu/OK, and then press ▲ or ▼ until you see >Audio Settings.

Press Menu/OK again. Press ▲ or ▼ until you see >Tones.

Press Menu/OK again. Press ▲ or ▼ to choose from the list of tones above.

Press Menu/OK again. Press ▲ or ▼ to select >On or >Off. Press Menu/OK to confirm.

Press DEL/Mute 3 times to return to the idle screen.

## 20 Key Lock

To prevent accidental key presses, from the idle mode, press and *hold* #. Release # when the 'key' icon appears on the top line of the display. Your keypad is now locked.

To unlock the keypad, press and hold # until the 'key' icon disappears.

The following numbers can still be dialed when the keypad is locked:

911      000

## 21 Handset Power

You can turn the power off on your Handset. Press and *hold* DEL/Mute until the screen changes, indicating shut down mode. To power the Handset up again, press and hold DEL/Mute until you see activity on the display.

## **PART III ADVANCED SETTINGS**

### **22 Advanced Settings Menu**

The Advanced Settings menu gives you access to the following options:

RESET HANDSET  
CHANGE PIN  
REGISTER  
SELECT BASE  
DEREGISTER

To access these options, from the idle mode:

Press Menu/OK, and then press ▲ or ▼ until you see >Adv. Settings.

Press Menu/OK again. Press ▲ or ▼ to choose from the list of options above.

#### **Reset Handset**

To restore your Handset to all factory preset settings:

When you see >Reset handset, press Menu/OK.

Your will see Enter HS PIN: :\_\_\_\_.

Enter the 4-digit Handset PIN (preset to 0000).

Scroll ▼ to >YES, and then press Menu/OK.

#### **Change Pin (Handset)**

Your Handset PIN is factory preset to 0000. To prevent unauthorized adjustment of the advanced Handset settings, you can select a new 4-digit PIN (this is optional; you do not have to change the PIN):

Scroll ▼ to >Change PIN, and then press Menu/OK.

Your will see Enter Old PIN :\_\_\_\_.

Enter the current 4-digit Handset PIN.

Enter the New Pin :\_\_\_\_.

Verify the New Pin :\_\_\_\_. You will see Pin Changed.

Press DEL/Mute twice to return to the idle screen.

#### **Registration (of Handsets)**

Your Handset is registered to the Base at the factory. Registration allows a Handset to communicate with a Base. You can register 5 additional Handsets (model 588002TP227F) to the Base. To register an additional Handset to the Base:

##### **Auto Registration (Recommended)**

Charge the 'new' Handset in its cradle overnight. You will see Not Registered on the display. Place it in the Base. In a short while, usually 60 seconds or less, the new Handset will be registered. The Handset will be assigned a number, located in the lower left corner of the display.

##### **Manual Registration**

Press and hold PAGE on the Base (for approximately 3 seconds) until you hear a soft beep.

In the Advanced Settings menu, scroll ▼ to >Register, and then press Menu/OK.

You will see Select Base. Scroll ▼ to the desired Base. If you have one Base, scroll ▼ to >Base 1. Press Menu/OK again.

You will see Please Wait... When prompted, Enter Base PIN: :\_\_\_\_.

You will see Please Wait... A tone will confirm registration. The idle screen will be displayed.



## Select Base

If you have registered a Handset to more than one Base, use this feature to select the Base to which you currently want to 'link' that Handset (a Handset can be registered to a maximum of 4 Base Units; however, it can only work with one Base at a time):

In the **Advanced Settings** menu, scroll ▼ to >Select Base, and then press **Menu/OK**.

You will see a list of a Base Units to which the Handset is registered. You will also see >Automatic. Scroll ▲/▼ to a specific Base or Automatic, and then press **Menu/OK**.

If you choose >Automatic, the Handset will search for all Bases to which it has been registered. If it locates more than one Base, the Handset will select the one to which it has been most recently registered.

## Deregister - Handset

From a registered Handset, you can deregister any Handset. The Base will no longer recognize the deregistered Handset:

In the **Advanced Settings** menu, scroll ▼/▲ to >Deregister?, and then press **Menu/OK**.

Enter the HS PIN: \_\_\_\_.

You will see **Deregister >Handset**. Press **Menu/OK**.

Scroll ▲/▼ to select the desired Handset, and then press **Menu/OK**.

You will see **Clear ?** Scroll ▼ to >Yes, and then press **Menu/OK** to confirm.

Press **DEL/Mute** twice to return to the idle screen.

## Deregister – Base

From a registered Handset, you can deregister that Handset from one or more Bases to which it is currently linked:

In the **Advanced Settings** menu, scroll ▼/▲ to >Deregister?, and then press **Menu/OK**.

Enter the HS PIN: \_\_\_\_.

You will see **Deregister**. Scroll ▼ to >Base. Press **Menu/OK**.

You will see **Select Base**. Scroll ▲/▼ to a desired >Base, and then press **Menu/OK**.

A check mark will appear by each Base you select for deregistration.

Press **Menu/OK** again. You will see **Clear?** Scroll ▼ to >Yes, and then press **Menu/OK** to confirm.

Press **DEL/Mute** twice to return to the idle screen.

## 23 Base Settings

The Base Settings menu gives you access to the following options:

- AUDIO – Base Ringer Volume and Melody
- RESET BASE – To all factory preset settings
- ADDITIONAL – Dial Mode; Flash Time; Prefix Dial No.
- CALL BARRING – Prevent unauthorized use of your phone
- BASE PIN – Change Base PIN (default PIN is 0000)

To access these options, from the idle mode:

Press **Menu/OK**, and then press ▲ or ▼ until you see >Base Settings.

Press **Menu/OK** again. Press ▲ or ▼ to choose from the list of options above.

## Audio

When you see >Audio, press **Menu/OK**, and then press ▲ or ▼ to select >Ringer Volume or >Ringer Melody.

Press Menu/OK again. Now, press ▲ or ▼ to adjust ringer volume or select a ringer melody. Press Menu/OK to confirm your selection.

## Reset Base

In the Base Settings menu, scroll ▼ to >Reset Base, and then press Menu/OK.  
You will see Reset to default. Scroll ▼ to >Yes, and then press Menu/OK.  
You will see Base is reset to default.

## Additional

In the Base Settings menu, scroll ▼ to >Additional, and then press Menu/OK.  
Scroll ▼ /▲ to select >Dial Mode, >Flash Time or >Prefix Dial No., and then press Menu/OK.

>Dial Mode – Press ▲ or ▼ to select >Tone or >Pulse, and then press Menu/OK to confirm your selection.

>Flash Time – Press ▲ or ▼ to select the desired flash time (preset to 600 ms), and then press Menu/OK to confirm your selection.

>Prefix Dial No. – Enter your Base PIN. Next, enter the desired prefix number, up to 22 digits, and then press Menu/OK. This prefix will be dialed at the beginning of every call you make. However, it will not be displayed on the screen. If you decide to stop using this feature, make sure you return to this setting, and use DEL/Mute to delete the Prefix Dial Number!!!!

Press DEL/Mute to return to the idle screen.

## Call Barring

When you see >Call Barring, press Menu/OK. Enter the Base PIN.  
Enter the number or number sequence that, if dialed, will prevent the Handset from dialing. For example, if you do not want long distance calls to go out (calls that begin with '1'), simply enter 1. If you do not want any calls to go out, leave the number field blank.  
Press Menu/OK. Now, press ▲ or ▼ to select Call Barring >On.  
Press Menu/OK to confirm your selection.

**WARNING:** To return to full dialling access, you will need to return to the Call Barring menu and select Call Barring >Off, following the steps above.

## Base Pin

Your Base PIN is factory preset to 0000. To prevent unauthorized changes to the Base Settings, you can select a new 4-digit PIN (this is optional; you do not have to change the PIN):

In the Base Settings menu, scroll ▼ /▲ to >Base PIN, and then press Menu/OK.  
You will see Enter Old PIN : \_\_\_\_\_. Enter the current Base PIN.  
Enter the New Pin : \_\_\_\_\_.  
Verify the New Pin : \_\_\_\_\_. You will see Base PIN is saved.  
Press DEL/Mute to return to the idle screen.

## FCC INFORMATION

**Part 68** is a Federal regulation which requires equipment to be tested and registered with the FCC prior to its connection to the network. This equipment complies with Part 68 of FCC rules. On the bottom of the telephone is a label that contains, among other information, the FCC Registration Number and the Ringer Equivalence Number (REN) for this equipment. You must, upon request, provide this information to your telephone company.

The **Ringer Equivalence Number**, which is used to determine the number of devices you may connect to your phone line, indicates the amount of power that your telephone draws from the telephone company line during ringing. If you have more than one telephone (or other terminal device) connected to the telephone company line, you should total the ringer equivalence numbers (REN s), and be sure that the total is not more than five. Your telephones may not ring if the total is more than five. Also, in some rural locations, your telephone may not ring if the REN total is more than three.

**RESTRICTIONS** You must not connect your telephone to coin-operated lines or party lines.

**INSTALLATION** This model telephone must be connected to the telephone company lines through a modular jack. The required USOC for the modular jack is RJ11C for desk mounting and RJ11W for wall mounting. The USOC number is printed on the label on the bottom of your telephone.

**HEARING-AID COMPATIBILITY** The handset on your telephone will work with magnetically-coupled hearing aids. You can use a hearing aid equipped with a T (Telephone) switch.

**IN CASE OF TROUBLE** If your telephone should cause problems on the telephone line, the telephone company can temporarily disconnect your service. The telephone company must then notify and allow you to correct the problem.

The telephone company may from time to time change its lines or equipment. They must notify you if planned changes will affect your telephone service, to allow you to take steps to prevent interruptions.

**Part 15** regulates the electromagnetic energy emitted by equipment to minimize interference to radio, television, and other wireless devices. This telephone complies with Part 15 of the FCC Rules. In the unlikely event that interference occurs, move the telephone and/or radio, television, etc. to increase the separation distance.

## LIMITED WARRANTY

If you purchased this product new in the U.S. or Puerto Rico, **CORTELCO** warrants it against defects in material and workmanship for a period of one (1) year from the date of original purchase. This warranty is in lieu of all other express warranties. During the warranty period, **CORTELCO** agrees to repair or, at its option, replace the defective product, or any part of it without charge for parts or labor. This is your exclusive remedy. This warranty does not cover damage resulting from accident, misuse, abuse, improper installation or operation, lack of reasonable care, the affixing of any attachment not provided by **CORTELCO** with the product and loss of parts. The warranty is voided in the event any unauthorized person alters or repairs the unit.

Telephone companies use different types of equipment and offer various types of services to customers. **CORTELCO does not warrant that this product is compatible with the type of equipment of any particular phone company or the services provided by it.**

**CORTELCO** DISCLAIMS ANY IMPLIED WARRANTY, INCLUDING THE WARRANTY OF MERCHANTABILITY AND THE WARRANTY OF FITNESS FOR A PARTICULAR PURPOSE, AS OF THE DATE ONE YEAR FROM THE ORIGINAL PURCHASE OF THE PRODUCT. **CORTELCO** ASSUMES NO RESPONSIBILITY FOR ANY SPECIAL, INCIDENTAL OR CONSEQUENTIAL DAMAGES.

THIS WARRANTY GIVES YOU SPECIFIC LEGAL RIGHTS, AND YOU MAY HAVE OTHER RIGHTS WHICH VARY FROM STATE TO STATE. SOME STATES DO NOT ALLOW THE EXCLUSION OR LIMITATION OF SPECIAL, INCIDENTAL OR CONSEQUENTIAL DAMAGES OR LIMITATIONS ON HOW LONG AN IMPLIED WARRANTY LASTS, SO THE ABOVE EXCLUSION AND LIMITATION MAY NOT APPLY TO YOU.

If failure occurs and your telephone is in warranty, service shall be provided by returning it to **CORTELCO - Repair Center, 1703 Sawyer Road, Corinth, Mississippi 38834, shipping prepaid**. The product will be repaired or replaced if examination by us determines the product to be defective. Telephones received damaged as a result of shipping will require you to file a claim with the carrier.