



**FIRSTSCOPE 70 & 90 EQ
TELESCOPE**

INSTRUCTION MANUAL

Firstscope 70 EQ - #21076



Firstscope 90 EQ - #21085

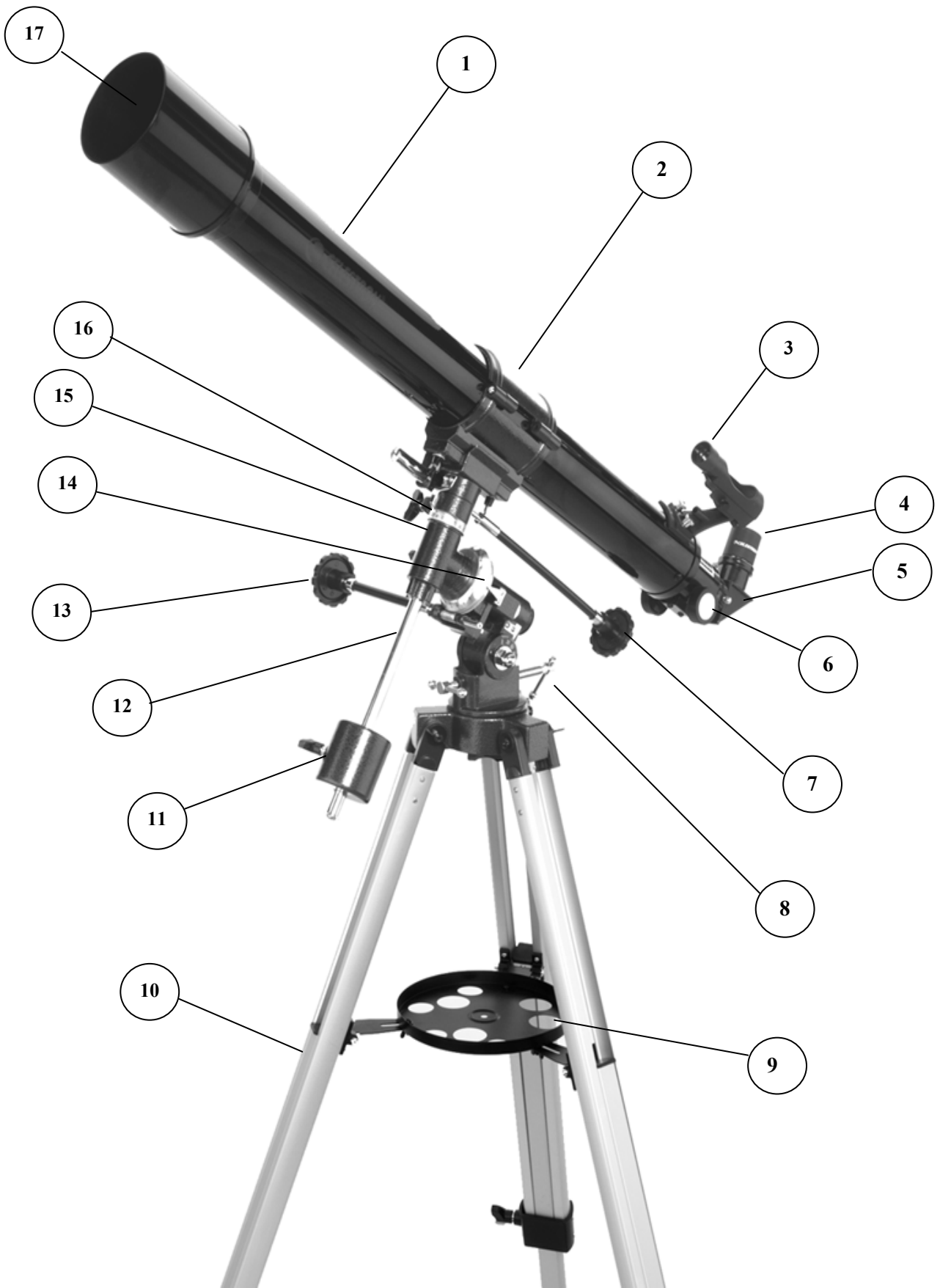

Firstscope Refractor
70mm EQ shown

IDENTIFYING PARTS OF YOUR FIRSTSCOPE

1. Telescope Tube
2. Tube Ring
3. Star Pointer Finderscope
4. Eyepiece
5. Star Diagonal
6. Focuser
7. Declination Slow Motion Cable
8. Latitude Adjustment Screws
9. Eyepiece Accessory Tray
10. Tripod
11. Counterweight
12. Counterweight Bar
13. Right Ascension Slow Motion Cable
14. Right Ascension Setting Circle
15. Equatorial Mount
16. Declination Circle
17. Objective Lens

INTRODUCTION

Thank you for purchasing this Celestron Refractor Telescope. This telescope is a precision scientific instrument. With it you will enjoy numerous objects in the sky—planets, nebulae, star clusters, galaxies and other astronomical objects.

This manual covers both the 70mm equatorial model and the 90mm model. The equatorial mount contains setting circles and slow motion cables to make it easier to locate and track astronomical objects.

But, before your journey begins take time to read this manual to familiarize yourself with the operation and parts of your telescope.



WARNING—NEVER LOOK AT THE SUN WITH YOUR TELESCOPE OR ITS FINDERSCOPE. PERMANENT AND IRREVERSIBLE EYE DAMAGE MAY RESULT AS WELL AS DAMAGE TO YOUR TELESCOPE. HOWEVER, YOU MAY ENJOY LOOKING AT THE SUN IF YOU HAVE A SAFE METHOD OF DOING SO, SUCH AS A CELESTRON SOLAR FILTER.

Assembling Your Telescope

- 1) Your Firstscope telescope should include all of the following:
 - a. Tripod with center support bracket
 - b. Telescope tube with tube ring attached
 - c. Equatorial mount head
 - d. Two 1 ¼" eyepieces
 - e. 90° star diagonal
 - f. StarPointer Finderscope
 - g. 2# Counterweight (Firstscope 70)
 - h. 5# Counterweight (Firstscope 90)
 - i. Counterweight bar
 - j. Two slow motion cables
 - k. Eyepiece accessory tray
 - l. *The Sky* CD rom
- 2) To set up the tripod, spread the legs outward until they are fully extended. Extend the center portion of each of the three tripod legs down 6-8". Use the three tightening screws located at the bottom of each leg to secure the extended legs in place.
- 3) Place the accessory tray on top of tripod's center leg brace. Thread the tray's threaded post into the threaded hole in the center of the leg brace.
- 4) Locate the equatorial mount and place the base of the mount through the hole in the center of the tripod mounting platform. From underneath the tripod mounting platform, thread the mounting bolt with washer into the threaded hole on the bottom of the equatorial mount.
- 5) Thread the latitude adjustment screws into the equatorial mount until both screws are touching the inside of the mount and the mount can no longer pivot up and down.
- 6) Locate the counterweight bar and counterweight. Thread the threaded end of the counterweight bar into the Dec axis of the equatorial mount. Remove the safety screw and washer from the other end of the counterweight bar. Loosen the counterweight locking bolt so that the screw is no longer obstructing the center hole of the counterweight. Slide the counterweight half way up the counterweight bar and tighten the locking screw to secure the counterweight in place. Thread the safety screw and washer on to the end of the counterweight bar.
- 7) Slide the chrome end of the slow motion control cables onto the equatorial mount gear shaft. See Figure A. The longer cable should attach to the Right Ascension axis and the shorter cable attaches to the Declination axis.
- 8) Remove the wing nuts from the threaded post at the bottom of the tube ring. Place the telescope tube on top of the equatorial mount so that the threaded posts slide through the holes on the equatorial mount. The declination slow motion cable should extend towards the focuser end of the telescope tube. Replace the wing nut and tighten to hold the telescope in place.
- 9) Remove the plastic cap covering the end of the focuser. Loosen the set screw on the focuser so that it does not obstruct the inner diameter of the focuser. Insert the chrome barrel of the star diagonal into the focuser and tighten the set screw.

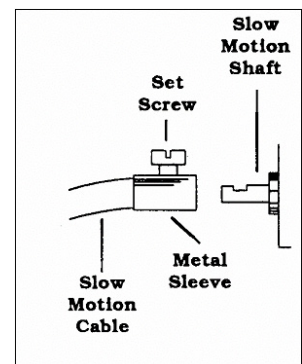

Figure A

- 10) Loosen the set screw on the star diagonal so that it does not obstruct the inner diameter of the barrel. Insert the chrome barrel of the 20mm eyepiece into the diagonal and tighten the set screw. See Figure B
- 11) Locate the StarPointer finderscope. Remove the knurled nuts on the threaded posts at the focuser end of the telescope tube. Mount the Star Pointer bracket by placing the bracket over the posts protruding from the tube and tightening it down with the knurled nuts. Orient the Star Pointer so that the glass window is facing towards the front of the tube.
- 12) Remove the lens cap from the front of the telescope.

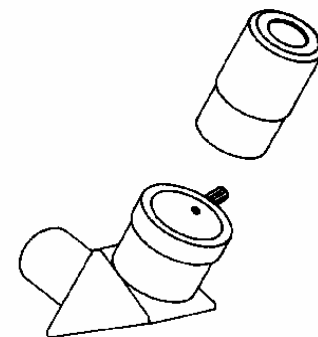

Figure B

TELESCOPE OPERATION — USING YOUR TELESCOPE

Star Pointer Finderscope

The Star Pointer is the quickest and easiest way to point your telescope exactly at a desired object in the sky. It's like having a laser pointer that you can shine directly onto the night sky. The Star Pointer is a zero magnification pointing tool that uses a coated glass window to superimpose the image of a small red dot onto the night sky. While keeping both eyes open when looking through the Star Pointer, simply move your telescope until the red dot, seen through the Star Pointer, merges with the object as seen with your unaided eye. The red dot is produced by a light-emitting diode (LED); it is not a laser beam and will not damage the glass window or your eye. The star pointer is powered by a long life 3-volt lithium battery (#CR2032) located underneath the front portion of the Star Pointer. Like all finderscopes, the Star Pointer must be properly aligned with the main telescope before it can be used. This is a simple process using the azimuth and altitude control knobs located on the side and bottom of the Star Pointer. The alignment procedure is best done at night since the LED dot will be difficult to see during the day.

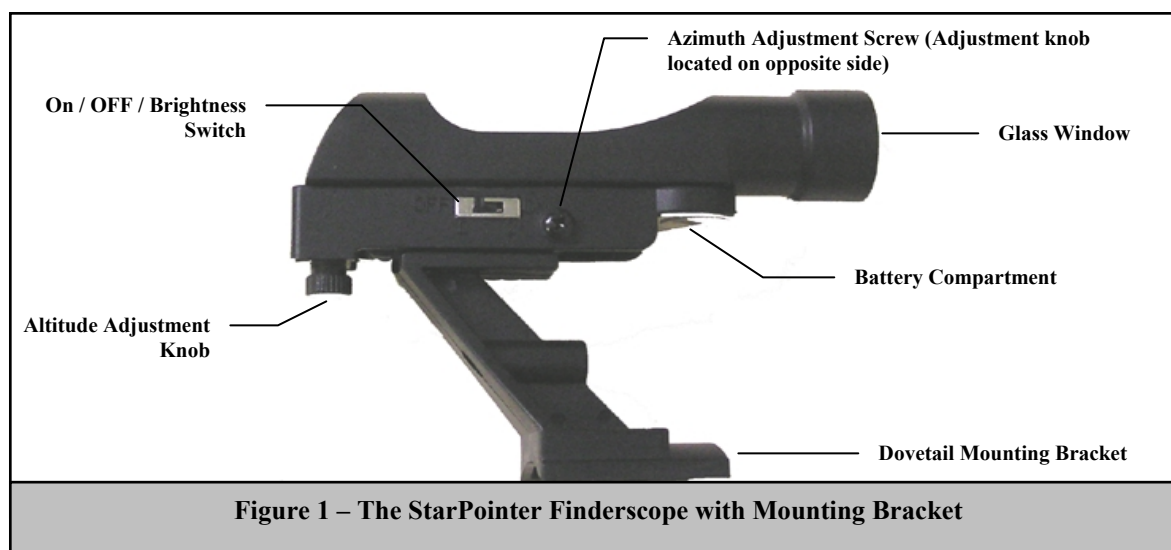

Figure 1 – The StarPointer Finderscope with Mounting Bracket

To align the Star Pointer finderscope:

1. Before using the StarPointer, you must first remove the protective plastic cover between the battery and the battery clip.

2. To turn on the Star Pointer, slide the On/Off switch to the 1 "On" position. To increase the brightness level of the red dot, slide the switch to the 2 "On" position.
3. Locate a bright star or planet and center it in a low power eyepiece in the main telescope.
4. With both eyes open, look through the glass window at the alignment star.
5. If the Star Pointer is perfectly aligned, you will see the red LED dot overlap the alignment star. If the Star Pointer is not aligned, take notice of where the red dot is relative to the bright star.
6. Without moving the main telescope, turn the Star Pointer's azimuth and altitude adjustment knobs until the red dot is directly over the alignment star.

The Star Pointer is now ready to be used. **Remember to always turn the power off after you have found an object. This will extend the life of both the battery and the LED.**

Moving Your Telescope:

To change the direction your telescope is pointing:

1. To move the telescope in declination (north/south) there are two options. For large and quick movements, loosen the declination knob (see figures 8 & 9) when moving the telescope and then tighten the knob when you are near the position you want. For very small movements and fine adjustments, use the declination cable. The declination cable has a range of about 30° and if you come to the stop at the end of its travel, **do not try to force movement when the declination cable has reached the stop.** Instead loosen the declination knob and manually move the telescope in declination until you pass the object in the opposite direction. Then tighten the knob and reverse the direction of the declination cable.
2. To move the telescope in right ascension (east/west) there are two options. For large and quick movements, loosen the right ascension knob when moving the telescope and then tighten the knob when you are near the position you want. For very small movements and fine adjustments, turn the right ascension cable. Unlike the declination cable, the right ascension cable has 360° of continuous motion.

Balancing the Telescope in Right Ascension (R.A.):

The telescope should be properly balanced in order for it to move smoothly in both axes. Proper balance is essential if using an optional motor drive for accurate tracking.

1. To balance the right ascension axis, move the counterweight shaft so it is parallel (horizontal) to the ground. (See figure 2). Slowly release the right ascension knob and see if the optical tube moves. If the optical tube moves, then slide the counterweight up or down the counterweight shaft until the optical tube remains stationary in the parallel position to the ground. When this happens, make sure the counterweight lock is tight.

Balancing the Telescope in Declination (DEC):

The telescope should also be balanced on the declination axis to prevent any sudden motions when the DEC clamp is released. To balance the telescope in DEC:

1. Release the R.A. clamp and rotate the telescope so that it is on one side of the mount (i.e., as described in the previous section on balancing the telescope in R.A.). Lock the R.A. clamp to hold the telescope in place. Release the DEC clamp and rotate the telescope until the tube is parallel to the ground (see figure 3). Release the tube — **GRADUALLY** — to see which way it rotates around the declination axis. **DO NOT LET GO OF THE TELESCOPE TUBE COMPLETELY!** Loosen the screws that hold the telescope tube inside the mounting rings and slide the telescope either forwards or backwards until it remains stationary when the DEC clamp is released. Tighten the tube ring screws firmly to hold the telescope in place.

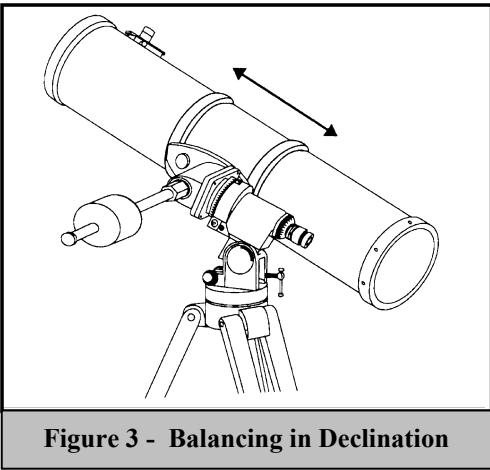
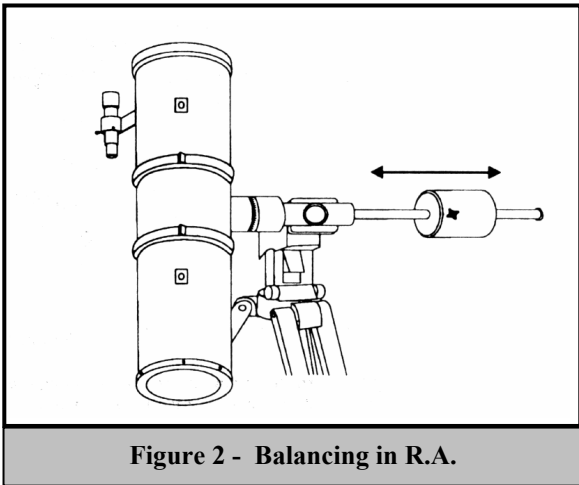

Telescope Basics

A telescope is an instrument that collects and focuses light. The nature of the optical design determines how the light is focused. Some telescopes, known as refractors, use lenses. Other telescopes, known as reflectors, use mirrors. Your Firstscope telescope is a refractor telescope that use an objective lens to collect its light.

Image Orientation

The image orientation of any telescope changes depending on how the eyepiece is inserted into the telescope. When observing through a refractor telescope using the star diagonal, the image will be right side up, but reversed from left to right. However, when observing straight through, with the eyepiece inserted directly into the telescope, the image will be inverted.

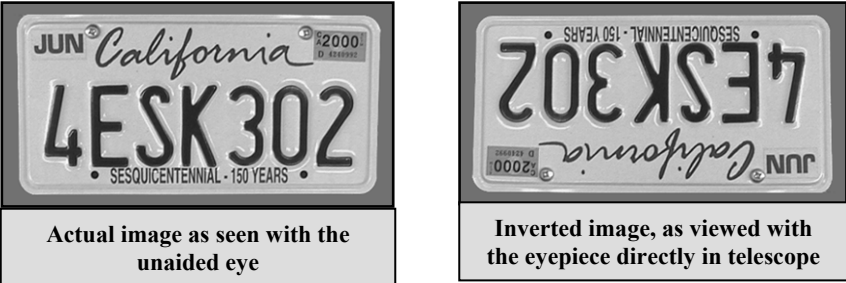

Figure 5

Focusing

To focus your telescope, simply turn the focus knob located directly below the eyepiece holder. Turning the knob clockwise allows you to focus on an object that is farther than the one you are currently observing. Turning the knob counterclockwise from you allows you to focus on an object closer than the one you are currently observing.

- If you wear corrective lenses (specifically glasses), you may want to remove them when observing with an eyepiece attached to the telescope. However, when using a camera you should always wear corrective lenses to ensure the sharpest possible focus. If you have astigmatism, corrective lenses must be worn at all times.

The Celestial Coordinate System

To help find objects in the sky, astronomers use a celestial coordinate system that is similar to our geographical coordinate system here on Earth. The celestial coordinate system has poles, lines of longitude and latitude, and an equator. For the most part, these remain fixed against the background stars.

The celestial equator runs 360 degrees around the Earth and separates the northern celestial hemisphere from the southern. Like the Earth's equator, it bears a reading of zero degrees. On Earth this would be latitude. However, in the sky this is referred to as declination, or DEC for short. Lines of declination are named for their angular distance above and below the celestial equator. The lines are broken down into degrees, minutes of arc, and seconds of arc. Declination readings south of the equator carry a minus sign (-) in front of the coordinate and those north of the celestial equator are either blank (i.e., no designation) or preceded by a plus sign (+).

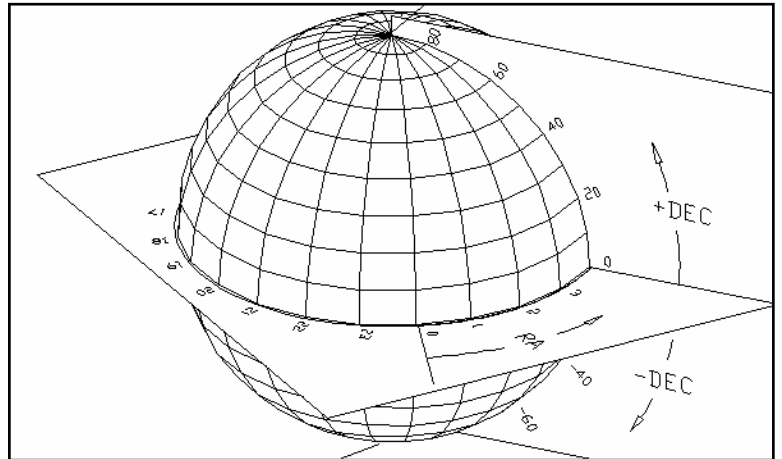

Figure 6
The celestial sphere seen from the outside showing R.A. and DEC.

The celestial equivalent of longitude is called Right Ascension, or R.A. for short. Like the Earth's lines of longitude, they run from pole to pole and are evenly spaced 15 degrees apart. Although the longitude lines are separated by an angular distance, they are also a measure of time. Each line of longitude is one hour apart from the next. Since the Earth rotates once every 24 hours, there are 24 lines total. As a result, the R.A. coordinates are marked off in units of time. It begins with an arbitrary point in the constellation of Pisces designated as 0 hours, 0 minutes, 0 seconds. All other points are designated by how far (i.e., how long) they lag behind this coordinate after it passes overhead moving toward the west.

Motion of the Stars

The daily motion of the Sun across the sky is familiar to even the most casual observer. This daily trek is not the Sun moving as early astronomers thought, but the result of the Earth's rotation. The Earth's rotation also causes the stars to do the same, scribing out a large circle as the Earth completes one rotation. The size of the circular path a star follows depends on where it is in the sky. Stars near the celestial equator form the largest circles rising in the east and setting in the west. Moving toward the north celestial pole, the point around which the stars in the northern hemisphere appear to rotate, these circles become smaller. Stars in the mid-celestial latitudes rise in the northeast and set in the northwest. Stars at high celestial latitudes are always above the horizon, and are said to be circumpolar because they never rise and never set. You will never see the stars complete one circle because the sunlight during the day washes out the starlight. However, part of this circular motion of stars in this region of the sky can be seen by setting up a camera on a tripod and opening the shutter for a couple hours. The processed film will reveal semicircles that revolve around the pole. (This

Stars seen near the north celestial pole

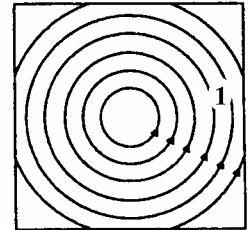

Stars seen near the celestial equator

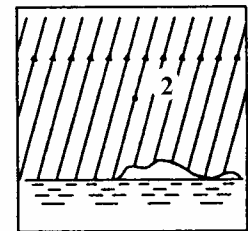

Stars seen looking in the opposite direction of the north celestial pole

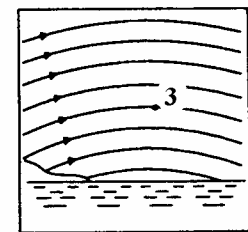

Figure 7

All stars appear to rotate around the celestial poles. However, the appearance of this motion varies depending on where you are looking in the sky. Near the north celestial pole the stars scribe out recognizable circles centered on the pole (1). Stars near the celestial equator also follow circular paths around the pole. But, the complete path is interrupted by the horizon. These appear to rise in the east and set in the west (2). Looking toward the opposite pole, stars curve or arc in the opposite direction scribing a circle around the opposite pole (3).

description of stellar motions also applies to the southern hemisphere except all stars south of the celestial equator move around the south celestial pole.)

Latitude Scales

The easiest way to polar align a telescope is with a latitude scale. Unlike other methods that require you to find the celestial pole by identifying certain stars near it, this method works off of a known constant to determine how high the polar axis should be pointed (see figure 10).

The constant, mentioned above, is a relationship between your latitude and the angular distance the celestial pole is above the northern (or southern) horizon; The angular distance from the northern horizon to the north celestial pole is always equal to your latitude. To illustrate this, imagine that you are standing on the north pole, latitude $+90^\circ$. The north celestial pole, which has a declination of $+90^\circ$, would be directly overhead (i.e., 90 above the horizon). Now, let's say that you move one degree south — your latitude is now $+89^\circ$ and the celestial pole is no longer directly overhead. It has moved one degree closer toward the northern horizon. This means the pole is now 89° above the northern horizon. If you move one degree further south, the same thing happens again. You would have to travel 70 miles north or south to change your latitude by one degree. As you can see from this example, the distance from the northern horizon to the celestial pole is always equal to your latitude.

If you are observing from Los Angeles, which has a latitude of 34° , then the celestial pole is 34° above the northern horizon. All a latitude scale does then is to point the polar axis of the telescope at the right elevation above the northern (or southern) horizon. To align your telescope:

1. Make sure the polar axis of the mount is pointing due north. Use a landmark that you know faces north.
2. Adjust the mount in altitude until the latitude indicator points to your latitude. Moving the mount affects the angle the polar axis is pointing.

This method can be done in daylight, thus eliminating the need to fumble around in the dark. Although this method does **NOT** put you directly on the pole, it will limit the number of corrections you will make when tracking an object.

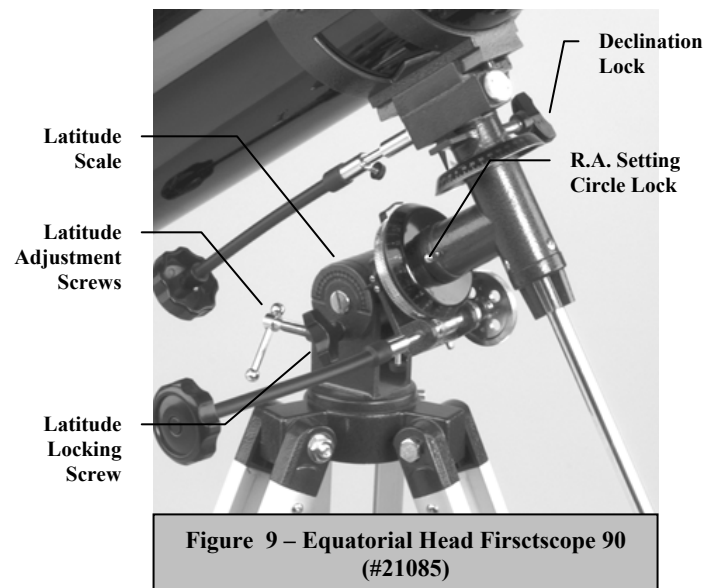
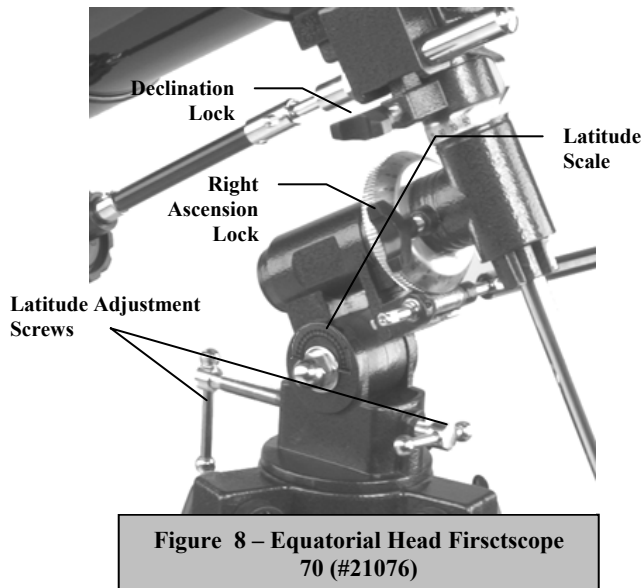

Pointing at Polaris

This method utilizes Polaris as a guidepost to the celestial pole. Since Polaris is less than a degree from the celestial pole, you can simply point the polar axis of your telescope at Polaris. Although this is by no means perfect alignment, it does get you within one degree. Unlike the previous method, this must be done in the dark when Polaris is visible.

1. Set the telescope up so that the polar axis is pointing north.
2. Loosen the DEC clutch knob and move the telescope so that the tube is parallel to the polar axis. When this is done, the declination setting circle will read $+90^\circ$. If the declination setting circle is not aligned, move the telescope so that the tube is parallel to the polar axis.

3. Adjust the mount in altitude and/or azimuth until Polaris is in the field of view of the finder.
4. Center Polaris in the field of the telescope using the fine adjustment controls on the mount.

Remember, while Polar aligning, do NOT move the telescope in R.A. or DEC. You do not want to move the telescope itself, but the polar axis. The telescope is used simply to see where the polar axis is pointing.

Like the previous method, this gets you close to the pole but not directly on it. The following methods help improve your accuracy for more serious observations and photography.

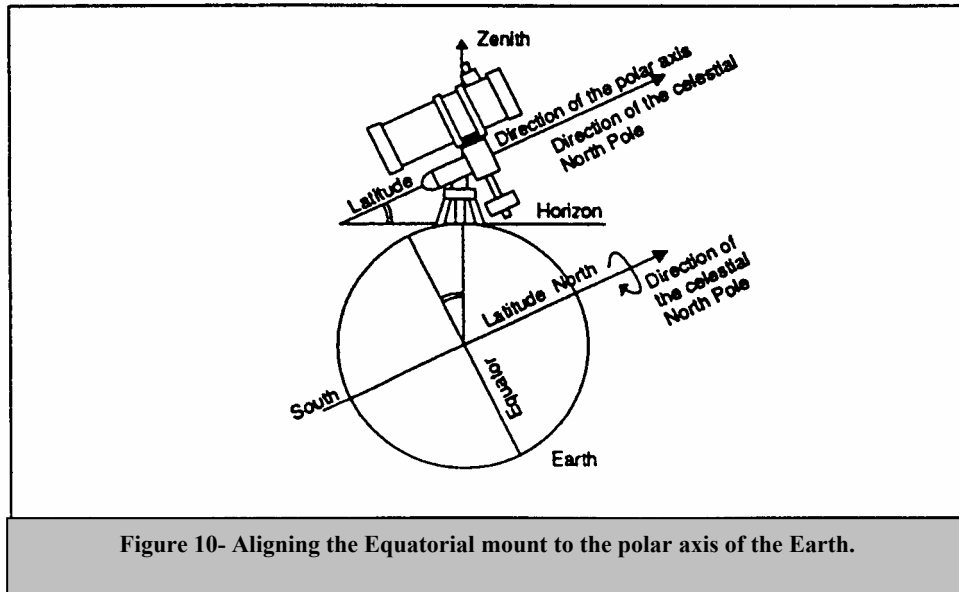

Figure 10- Aligning the Equatorial mount to the polar axis of the Earth.

Finding the North Celestial Pole

In each hemisphere, there is a point in the sky around which all the other stars appear to rotate. These points are called the celestial poles and are named for the hemisphere in which they reside. For example, in the northern hemisphere all stars move around the north celestial pole. When the telescope's polar axis is pointed at the celestial pole, it is parallel to the Earth's rotational axis.

Many methods of polar alignment require that you know how to find the celestial pole by identifying stars in the area. For those in the northern hemisphere, finding the celestial pole is not too difficult. Fortunately, we have a naked eye star less than a degree away. This star, Polaris, is the end star in the handle of the Little Dipper. Since the Little Dipper (technically called Ursa Minor) is not one of the brightest constellations in the sky, it may be difficult to locate from urban areas. If this is the case, use the two end stars in the bowl of the Big Dipper (the pointer stars). Draw an imaginary line through them toward the Little Dipper. They point to Polaris (see Figure 12). The position of the Big Dipper changes during the year and throughout the course of the night (see Figure 11). When the Big Dipper is low in the sky (i.e., near the horizon), it may be difficult to locate. During these times, look for Cassiopeia (see Figure 12). Observers in the southern hemisphere are not as fortunate as those in the northern hemisphere. The stars around the south celestial pole are not nearly as bright as those around the north. The closest star that is relatively bright is Sigma Octantis. This star is just within naked eye limit (magnitude 5.5) and lies about 59 arc minutes from the pole.

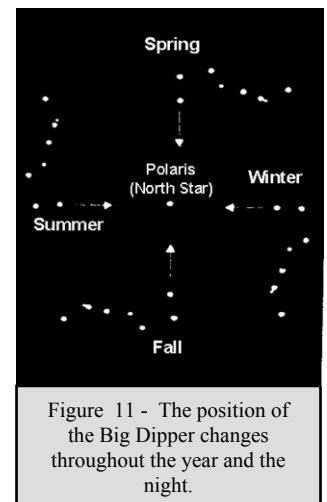

Figure 11 - The position of the Big Dipper changes throughout the year and the night.

Definition

The north celestial pole is the point in the northern hemisphere around which all stars appear to rotate. The counterpart in the southern hemisphere is referred to as the south celestial pole.

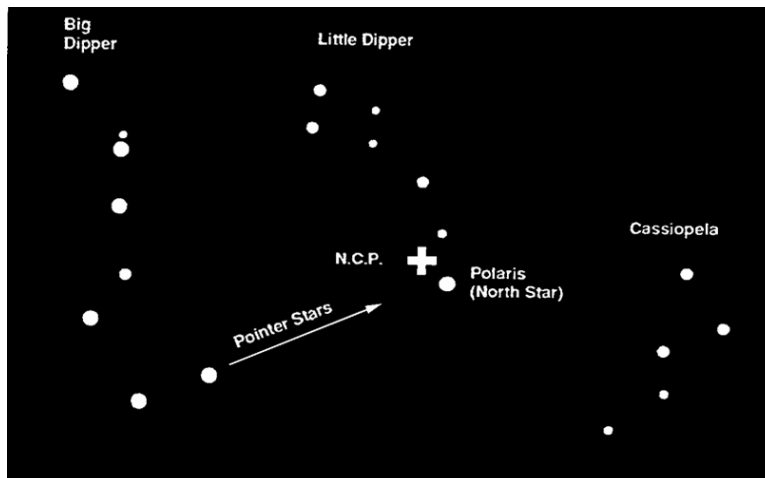

Figure 12

The two stars in the front of the bowl of the Big Dipper point to Polaris which is less than one degree from the true (north) celestial pole. Cassiopeia, the “W” shaped constellation, is on the opposite side of the pole from the Big Dipper. The North Celestial Pole (N.C.P.) is marked by the “+” sign.

Using the Setting Circles

Setting Circles are dials (or gauges) for right ascension and declination that allow you to locate celestial objects easily from their coordinates as listed in a star chart or atlas.

1. The declination setting circle (#16) is scaled in degrees and the right ascension setting circle is incremented in minutes. The circles will get you close to your target but not directly on it. Also, the accuracy of your polar alignment will affect how accurate your setting circles read.
2. The declination setting circle is factory set and should not need any adjustment if it reads accurately.
3. The right ascension setting circle (#14) must be aligned. Choose a bright and easy to find star in a star chart and note the coordinates (right ascension and declination). Find the star in the Star Pointer and then in the telescope. Now, rotate the right ascension circle to match the coordinates of the star with the indicator mark. If you polar aligned the telescope accurately, the declination circle should be correctly set to the proper coordinates.

Note

You may notice that there are two sets of numbers on the right ascension dial, one for the northern hemisphere and one for the southern. Observers in the northern hemisphere should use the upper set of numbers while southern observers should use the lower set of numbers. Remember in the northern hemisphere, the right ascension should decrease as the telescope is moved towards the west.

4. The right ascension setting circle does not move as the telescope moves in right ascension and thus it must be aligned each time you want to use it to find a new object. However, you do not need to use a bright star each time but you can use the object you are currently observing.
5. Now, using a star chart or atlas you can find numerous objects. First move the telescope in declination to the correct declination coordinate. Then move the telescope in right ascension until the indicator points to the correct coordinate.
6. After moving the telescope to the correct celestial coordinates, look through the lower power eyepiece to see if you have located the object you wish to view. Center the object in eyepiece. If the object is not visible in the eyepiece, gradually pan the telescope, using the right ascension and declination cables, until the object is visible. Always start by using your lowest power eyepiece (20mm) then switching to higher power once you have found the desired object.

MAGNIFICATION (POWER)

The magnification (or power) of a telescope is variable depending upon the focal length of the eyepiece being used along with the focal length of the telescope. In equation format, the formula looks like this:

$$\text{Magnification} = \frac{FL(\text{telescope})}{FL(\text{eyepiece})}$$

To determine the magnification using the standard 20mm eyepiece, simply divide the focal length of your telescope by the focal length of the eyepiece (20mm). For example, dividing the focal length of the Firstscope 90 (1000mm) by 20mm yields a magnification of 50 power.

Magnification through the telescope has its limits. These limits are determined by the laws of optics and the nature of the human eye. The maximum usable power is equal to 60 times the aperture of the telescope (in inches). For example, using the 70mm model (2.8") then your maximum useful power is 168x (2.8" x 60). You can create power higher than this limit but the images will be dark and blurred with poor contrast.

The maximum power is used only under ideal conditions which are not common. Most of your viewing will be done in the range of 25x to 120x. Higher powers are used mainly for lunar and planetary observing under ideal seeing conditions.

Determining Field of View

Determining the field of view is important if you want to get an idea of the angular size of the object you are observing. To calculate the actual field of view, divide the apparent field of the eyepiece (supplied by the eyepiece manufacturer) by the magnification. In equation format, the formula looks like this:

$$\text{True Field} = \frac{\text{Apparent Field of Eyepiece}}{\text{Magnification}}$$

As you can see, before determining the field of view, you must calculate the magnification. Using the example in the previous section, we can determine the field of view using the same 20mm eyepiece. The 20mm eyepiece has an apparent field of view of 45°. Divide the 45° by the magnification, which is 50 power. This yields an actual field of .9°, or almost a full degree.

To convert degrees to feet at 1,000 yards, which is more useful for terrestrial observing, simply multiply by 52.5. Continuing with our example, multiply the angular field .9° by 52.5. This produces a linear field width of over 47 feet at a distance of one thousand yards. The apparent field of each eyepiece that Celestron manufactures is found in the Celestron Accessory Catalog (#93685).

CELESTIAL OBSERVING

Now that your telescope is set up, you're ready to use it for observing. This section covers visual observing for both solar system and deep-sky objects.

Observing the Moon

In the night sky, the moon is a prime target for your first look because it is extremely bright and easy to find. Although the beauty of the full moon may make it seem a perfect viewing object, in fact, the light reflected from its fully illuminated face can be overpowering. In addition, little or no contrast can be seen during this phase.

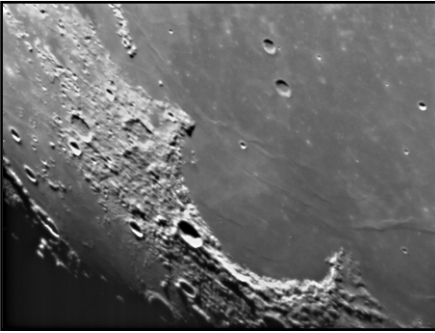

One of the best times to observe the moon is during its partial phases, such as a crescent or quarter moon. At these times, long shadows reveal a great amount of detail on the lunar surface. At low power, with the standard eyepiece, you'll be able to see the whole lunar disk at one time. Change to higher power (magnification) with an optional eyepiece to focus in on a smaller area. Keep in mind that the rotation of the earth will cause the moon to drift out of your field of view. You'll have to manually adjust the telescope to keep the moon centered.

This effect is more noticeable at higher power. Consult a current astronomy magazine or your local newspaper to find out the current phase of the moon.

Lunar Observing Hint

To increase contrast and bring out visible detail on the lunar surface, try using different filters (available through your local **Celestron** dealer). A yellow filter works well for improving contrast.

Observing the Planets

Other easy targets include the five "naked eye" planets of our solar system, so called because they can be spotted in the night sky by the unaided eye. You can see **Venus** go through its lunar-like phases. **Mars** can reveal a host of surface detail and one, if not both, of its polar caps. You'll be able to see the cloud belts of **Jupiter**, perhaps even the great Red Spot. In addition, you'll be able to see the moons of Jupiter as they orbit the giant planet. **Saturn**, with its beautiful rings, is easily visible at moderate power, as is **Mercury**. All you need to know is where to look. Most astronomy publications indicate where the planets are in the sky each month.

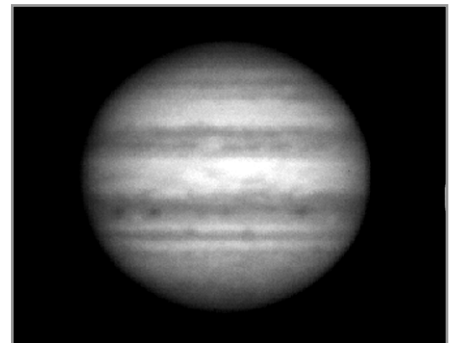

Observing Deep-Sky Objects

Deep-sky objects are simply those objects outside the boundaries of our solar system. They include star clusters, planetary nebulae, diffuse nebulae, double stars and other galaxies outside our own Milky Way. Unlike the sun, moon and our five major planets, most deep-sky objects are not visible to the naked eye. Finding them requires a method called star hopping. **Celestron Sky Maps (#93722)** can help you locate the brightest deep-sky objects.

Most deep-sky objects have a large angular size. Therefore, a low-to-moderate power eyepiece is all you need to see them. Visually, they are too faint to reveal any of the color seen in long exposure photographs. Instead, they appear black and white. Because of their low surface brightness, they should be observed from a “dark-sky” location. Light pollution around large urban areas washes out most nebulae making them difficult, if not impossible, to observe.

“Seeing” Conditions

Viewing conditions affect what you can see through your telescope during an observing session. Conditions include transparency, sky illumination and “seeing”. Understanding viewing conditions and the affect they have on observing will help you get the most out of your telescope.

Transparency

Transparency refers to the clarity of the atmosphere and is affected by clouds, moisture, dust and other airborne particles. Thick cumulus clouds are completely opaque, while cirrus clouds can be thin, allowing light from the brightest stars through. Hazy skies absorb more light than clear skies, making fainter objects hard to see and reducing contrast on brighter objects. Dust particles and gases ejected into the upper atmosphere from volcanic eruptions also affect transparency. Ideal conditions are when the night sky is inky black.

Sky Illumination

General sky brightening caused by the moon, aurorae, natural airglow and light pollution greatly affect transparency. While not a problem when viewing brighter stars and planets, bright skies reduce the contrast of extended nebulae, making them difficult, if not impossible, to see. To maximize your observing, limit deep-sky viewing to moonless nights, far from the light polluted skies found around major urban areas. Light Pollution Reduction (LPR) filters enhance deep-sky viewing from light polluted areas by blocking unwanted light, while transmitting light from certain deep-sky objects. Planets and stars can still be observed from light polluted areas or when the moon is out.

“Seeing”

The terms “seeing conditions” or “seeing” refer to the stability of the atmosphere, which directly effects the amount of fine detail seen in extended objects. Essentially, extended objects are objects other than stars, of some size, such as nebulae and galaxies.

The air in our atmosphere acts as a lens, which bends and distorts incoming light rays. The amount of bending depends on air density. Varying temperature layers have different densities and, therefore, bend light differently. Light rays from the same object arrive slightly displaced, creating an imperfect or smeared image. These atmospheric disturbances vary from time-to-time and place-to-place. Another form of turbulence that affects seeing conditions is referred to as “air parcels”. These air parcels are the smaller turbulence patterns in the air, within your immediate environment. The size of the air parcels, compared to the aperture of your telescope, also determines seeing quality. Under good seeing conditions, fine detail is visible on the brighter planets like Jupiter and Mars, and stars are pinpoint images. Under poor seeing conditions, images are blurred and star images are diffuse. Seeing conditions are rated on a five-point scale with one being the worst

condition and give the best. Seeing conditions can be classified in one of three categories. The definitions of these categories are based on the causes of the different seeing conditions.

Type 1 seeing conditions are characterized by rapid changes in the image seen through the telescope. Extended objects, like the moon, appear to shimmer while point sources (stars) appear double. Type 1 seeing is caused by air currents within, or very close to, the telescope tube. These currents are caused by a telescope that has not reached thermal equilibrium with the outdoor surroundings or heat waves from people standing near the telescope. To avoid the problems associated with Type 1 seeing, allow your telescope approximately 30 minutes outdoors to reach thermal equilibrium with the environment. If observing with others, make sure no one stands in front of or directly below the telescope tube.

The images produced by **Type 2** seeing conditions don't move as quickly as those produced by Type 1 conditions, but the images are quite blurry. Fine detail is lost and contrast is low for extended objects. Stars appear spread out and lack sharpness. Type 2 seeing conditions are produced in the lower atmosphere, most likely by heat waves from the ground or buildings. To avoid the problems associated with Type 2 seeing, select a good observing site. Look for broad hilltops or open grassy fields. Stable thermal conditions found near lakes and atmospheric inversions tend to produce good seeing. Avoid sites that overlook asphalt parking lots, plowed fields, valleys or shorelines. If you can't get a better location, wait until the early morning hours when the surroundings are uniformly cool and seeing is generally better.

Type 3 seeing conditions are characterized by fast ripples that create shimmer in the visual field, affecting otherwise sharp images. For extended objects, fine details are visible, but images shift around the field. Stars are crisp points, but they rapidly shift small distances within the field of view. The cause of Type 3 seeing is turbulence in the upper atmosphere, which means the observer has no control over it. However, the effects of Type 3 seeing are generally less pronounced than those of Type 1 and 2 conditions. Type 3 seeing conditions can't really be avoided, so your best bet is to wait for moments of atmospheric steadiness. If seeing conditions are extremely bad, you might consider waiting for a better night.

The conditions described here apply to both visual and photographic observations.



Figure 13

Seeing conditions directly affect image quality. These drawings represent a point source (i.e., star) under bad seeing conditions (left) to excellent conditions (right). Most often, seeing conditions produce images that lie somewhere between these two extremes.

TELESCOPE MAINTENANCE

With proper care your telescope should rarely need any maintenance work.

- A. When not in use, always replace all lens covers to keep dust and contaminants off the optical surfaces.
- B. A small amount of dust on any optical surface is ok. If the dust builds up then use a can of compressed air and then a camel's hair brush to remove the dust.
- C. If the lens need cleaning, it should be cleaned by a professional. Either have your instrument serviced by a telescope repair facility or return it to the factory.

SPECIFICATIONS

	<u>#21076</u>	<u>#21085</u>
Optical System:	Refractor	Refractor
Aperture:	70mm (2.8")	90mm (3.5")
Focal Length:	900mm	1000mm
F/ratio:	f/13	f/11
Focuser	Rack and Pinion	Rack and Pinion
Standard Oculars (or Eyepieces)	20mm 1¼" (45x) 10mm 1¼" (90x)	20mm 1¼" (50x) 10mm 1¼" (100x)
Resolution	1.7 arc seconds	1.3 arc seconds
Light gathering Power	100x unaided eye	165x unaided eye
Limiting Magnitude	11.4	12.3
Highest useful Power	142x	213x

NOTE: Specifications are subject to change without notice.

OPTIONAL ACCESSORIES

You will find that additional accessories enhance your viewing pleasure and expand the usefulness of your telescope. For ease of reference, all the accessories are listed in alphabetical order.

Barlow Lens - A Barlow lens is a negative lens that increases the focal length of a telescope. Used with any eyepiece, it doubles the magnification of that eyepiece. Celestron offers two Barlow lens in the 1-1/4" size. The 2x Ultima Barlow (#93506) is a compact triplet design that is fully multicoated for maximum light transmission and parfocal when used with the Ultima eyepieces. The OMNI Barlow (#93326) is a compact achromatic Barlow lens that is under three inches long and weighs only 4 oz. It works very well with all Celestron eyepieces.

Exotherm (#93504)- Perfect for chilly evenings outdoors camping, stargazing, or at sporting events, the Exotherm hand warmer is convenient, reusable and made from nontoxic materials. Heat lasts up to 1 hour.



Eyepieces - Like telescopes, eyepieces come in a variety of designs. Each design has its own advantages and disadvantages. For the 1-1/4" barrel diameter there are four different eyepiece designs available.

- **OMNI Plössl** - Plössl eyepieces have a 4-element lens designed for low-to-high power observing. The Plössls offer razor sharp views across the entire field, even at the edges! In the 1-1/4" barrel diameter, they are available in the following focal lengths: 4mm, 6mm, 9mm, 12.5mm, 15mm, 20mm, 25mm, 32mm and 40mm.
- **X-Cel** - This 6 element design allows each X-Cel Eyepiece to have 20mm of eye relief, 55° field of view and more than 25mm of lens aperture (even with the 2.3mm). In order to maintain razor sharp, color corrected images across its 55° field of view, extra-low dispersion glass is used for the most highly curved optical elements. The excellent refractive properties of these high grade optical elements, make the X-Cel line especially well suited for high magnification planetary viewing where sharp, color-free views are most appreciated. X-Cel eyepiece come in the following focal lengths: 2.3mm, 5mm, 8mm, 10mm, 12.5mm, 18mm, 21mm, 25mm.



- **Ultima** - Ultima is our 5-element, wide field eyepiece design. In the 1-1/4" barrel diameter, they are available in the following focal lengths: 5mm, 7.5mm, 10mm, 12.5mm, 18mm, 30mm, 35mm, and 42mm. These eyepieces are all parfocal.
- **Axiom** – As an extension of the Ultima line, a new wide angle series is offered – called the Axiom series. All units are seven element designs and feature a 70° extra wide field of view (except the 50mm). All are fully multicoated and contain all the features of the Ultimas.

Filters Sets, Eyepiece - Celestron offers four convenient filter sets, which contain four different filters per set. Not only are these highly useful filter combinations, but they also offer an economical way to add versatility to your filter collection.

Series 1 – #94119-10

Orange, Light Blue, ND13%T, Polarizing (#s 21, 80A, #15, Polarizing)

Series 2 – #94119-20

Deep Yellow, Red, Light Green, ND25% T (#s 12, 25, 56, 96ND-25)

Series 3 – #94119-30

Light Red, Blue, Green, ND50% T (#s 23A, 38A, 58, 96ND-50)

Series 4 – #94119-40

Yellow, Deep Yellow, Violet, Pale Blue (#s 8, 47, 82A, 96ND-13)



Flashlight, Night Vision - (#93588) - Celestron’s premium model for astronomy, using two red LED’s to preserve night vision better than red filters or other devices. Brightness is adjustable. Operates on a single 9 volt battery (included).

Light Pollution Reduction (LPR) Filters (#94126A) - These filters are designed to enhance your views of deep sky astronomical objects when viewed from urban areas. LPR Filters selectively reduce the transmission of certain wavelengths of light, specifically those produced by artificial lights. This includes mercury and high and low pressure sodium vapor lights. In addition, they also block unwanted natural light (sky glow) caused by neutral oxygen emission in our atmosphere.

Moon Filter (#94119-A) - Celestron’s Moon Filter is an economical eyepiece filter for reducing the brightness of the moon and improving contrast, so greater detail can be observed on the lunar surface. The clear aperture is 21mm and the transmission is about 18%.

Motor Drive (#93514) - Allows telescopes to track the motion of the sky once the telescope is polar aligned. This model is a single axis (R.A.), DC motor drive. It is powered by two 9-volt alkaline batteries which lasts up to 40 hours. A speed rate regulator is included to adjust the speed slightly faster or slower.

Peterson First Guides® - Astronomy (#93728)

A simplified field guide to the stars, the planets and the universe featuring full color maps showing the positions of the stars throughout the year. This useful guide also includes beautiful constellation paintings, photographs, and clear, concise descriptions of stars, the planets, the sun, the moon, comets, black holes, galaxies and more.

Polarizing Filter Set (#93608) - The polarizing filter set limits the transmission of light to a specific plane, thus increasing contrast between various objects. This is used primarily for terrestrial, lunar and planetary observing.

Sky Maps (#93722) - Celestron Sky Maps are the ideal teaching guide for learning the night sky. You wouldn’t set off on a road trip without a road map, and you don’t need to try to navigate the night sky without a map either. Even if you already know your way around the major constellations, these maps can help you locate all kinds of fascinating objects.

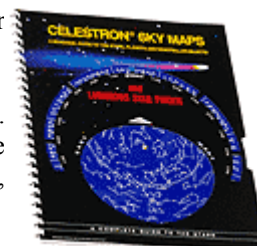

Solar Filters, 70mm (#94135) - Celestron Solar Filters are made with Baader Astro Solar™ Safety Film. Far superior than any existing glass, Mylar or polymer filters, they lead to brighter, sharper, and higher contrast images. The Sun appears in its “real” color —neutral white, not blue or orange, and the sky adjacent to the solar limb is jet

black. You can see detail in sunspots, bright faculae near the limb and the mottled areas known as granules with these filters. The Sun offers constant changes and will keep your observing interesting and fun. Even small aperture telescopes can enjoy features of the Sun.

T-Adapter (#93625) - T-Adapter (with additional T-Ring) allows you to attach your SLR camera to the rear cell of your Celestron telescope. This turns your telescope into a high power telephoto lens perfect for terrestrial photography and short exposure lunar and filtered solar photography.

A full description of all Celestron accessories can be found in the Celestron Accessory Catalog (#93685) or web site www.celestron.com

CELESTRON TWO YEAR WARRANTY

- A. Celestron warrants this telescope to be free from defects in materials and workmanship for two years. Celestron will repair or replace such product or part thereof which, upon inspection by Celestron, is found to be defective in materials or workmanship. As a condition to the obligation of Celestron to repair or replace such product, the product must be returned to Celestron together with proof-of-purchase satisfactory to Celestron.
- B. The Proper Return Authorization Number must be obtained from Celestron in advance of return. Call Celestron at (310) 328-9560 to receive the number to be displayed on the outside of your shipping container.

All returns must be accompanied by a written statement setting forth the name, address, and daytime telephone number of the owner, together with a brief description of any claimed defects. Parts or product for which replacement is made shall become the property of Celestron.

The customer shall be responsible for all costs of transportation and insurance, both to and from the factory of Celestron, and shall be required to prepay such costs.

Celestron shall use reasonable efforts to repair or replace any telescope covered by this warranty within thirty days of receipt. In the event repair or replacement shall require more than thirty days, Celestron shall notify the customer accordingly. Celestron reserves the right to replace any product which has been discontinued from its product line with a new product of comparable value and function.

This warranty shall be void and of no force of effect in the event a covered product has been modified in design or function, or subjected to abuse, misuse, mishandling or unauthorized repair. Further, product malfunction or deterioration due to normal wear is not covered by this warranty.

CELESTRON DISCLAIMS ANY WARRANTIES, EXPRESS OR IMPLIED, WHETHER OF MERCHANTABILITY OF FITNESS FOR A PARTICULAR USE, EXCEPT AS EXPRESSLY SET FORTH HEREIN.

THE SOLE OBLIGATION OF CELESTRON UNDER THIS LIMITED WARRANTY SHALL BE TO REPAIR OR REPLACE THE COVERED PRODUCT, IN ACCORDANCE WITH THE TERMS SET FORTH HEREIN. CELESTRON EXPRESSLY DISCLAIMS ANY LOST PROFITS, GENERAL, SPECIAL, INDIRECT OR CONSEQUENTIAL DAMAGES WHICH MAY RESULT FROM BREACH OF ANY WARRANTY, OR ARISING OUT OF THE USE OR INABILITY TO USE ANY CELESTRON PRODUCT. ANY WARRANTIES WHICH ARE IMPLIED AND WHICH CANNOT BE DISCLAIMED SHALL BE LIMITED IN DURATION TO A TERM OF TWO YEARS FROM THE DATE OF ORIGINAL RETAIL PURCHASE.

Some states do not allow the exclusion or limitation of incidental or consequential damages or limitation on how long an implied warranty lasts, so the above limitations and exclusions may not apply to you.

This warranty gives you specific legal rights, and you may also have other rights which vary from state to state.

Celestron reserves the right to modify or discontinue, without prior notice to you, any model or style telescope.

If warranty problems arise, or if you need assistance in using your telescope contact:

Celestron
Customer Service Department
2835 Columbia Street
Torrance, CA 90503 U.S.A.
Tel. (310) 328-9560
Fax. (310) 212-5835
Monday-Friday 8AM-4PM PST

All authorized returns should be shipped to :
Celestron
1380 Charles Willard St
Carson, CA 90747

This warranty supersedes all other product warranties.

NOTE: This warranty is valid to U.S.A. and Canadian customers who have purchased this product from an Authorized Celestron Dealer in the U.S.A. or Canada. Warranty outside the U.S.A. and Canada is valid only to customers who purchased from a Celestron Distributor or Authorized Celestron Dealer in the specific country and please contact them for any warranty service.



Celestron
2835 Columbia Street
Torrance, CA 90503 U.S.A.
Tel. (310) 328-9560
Fax. (310) 212-5835
Web site at www.celestron.com

Copyright 2004 Celestron
All rights reserved.

(Products or instructions may change
without notice or obligation.)

Item # 21076-INST
\$10.00

01-05

Printed in China