

CELESTRON®

Model # 31030

**FIRSTSCOPE 76 3" NEWTONIAN
ALTAZIMUTH TELESCOPE**

Model # 31030 - WOS

**FIRSTSCOPE 76 3" NEWTONIAN
ALTAZIMUTH TELESCOPE**

**This Model is made custom for the World of Science and has a custom
black optical tube.**

Model # 31031

**FIRSTSCOPE 76 EQ 3" NEWTONIAN
EQUATORIAL TELESCOPE**

Model # 31046

**FIRSTSCOPE 114 SHORT 4.5" NEWTONIAN
EQUATORIAL TELESCOPE**

INSTRUCTION MANUAL

Equatorial Model

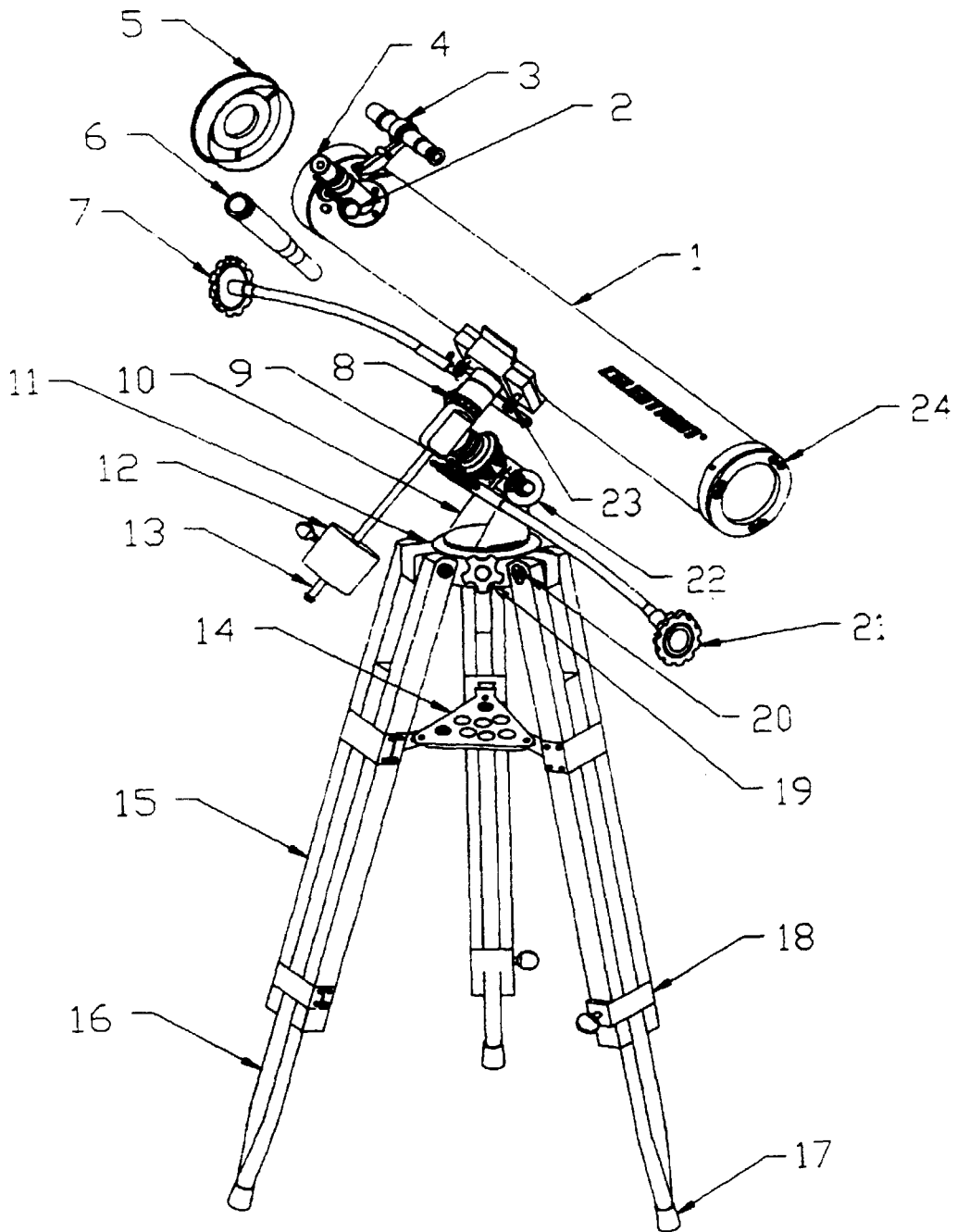

Figure 1

Altazimuth Model

NOTE: Tripod and tube parts are the same as for the equatorial mount in Figure 1. Only those items that are different are labeled.

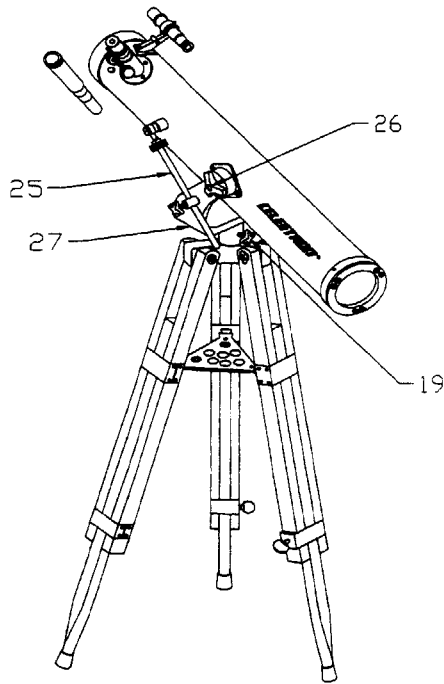

FIGURE 2

NO.	REQ'D.	PART NO.	DESCRIPTION
1	1		TUBE
2	1		FOCUSER
3	1		FINDER SCOPE & BRACKET
4	1		12.5MM & 8MM EYEPIECE - 0.96
5	1		LENS CAP
6	1		2X BARLOW - 0.96
7	1		FLEX CABLE
8	1		DEC SETTING CIRCLE
9	1		RA SETTING CIRCLE
10	1		EQUATORIAL MOUNT
11	1		TRIPOD HEAD
12	1		COUNTERWEIGHT
13	1		COUNTERWEIGHT SHAFT
14	1		ACCESSORY TRAY
15	3		TRIPOD LEG
16	3		TELESCOPE LEG
17	3		RUBBER FEET
18	3		LEG CLAMP
19	1		PIVOT SCREW
20	3		TRIPOD HINGE SCREW & NUT
21	1		FLEX CABLE
22	1		LATITUDE ADJUSTMENT
23	2		TUBE MOUNTING SCREW
24	3		ALIGNMENT SCREWS
25	1		ALTITUDE SLOW MOTION ROD ASSEMBLY
26	2		ALTITUDE ADJUSTMENT SCREWS
27	1		ALTAZIMUTH MOUNT

1. INTRODUCTION

Thank you for purchasing this Celestron Newtonian Telescope. This telescope is a precision scientific instrument. With it you will enjoy numerous objects in the sky—planets, nebulae, star clusters, galaxies and other astronomical objects.

This manual covers both the equatorial mount models (see Figure 1) and the altazimuth mount models (see Figure 2). The altazimuth mount is the simplest and easiest type of mount to use with two motions—altitude (up and down) and azimuth (side-to-side). The equatorial mount is more expensive and contains setting circles and slow motion cables to make it easier to locate and track astronomical objects.

But, before your journey begins take time to read this manual to familiarize yourself with the operation and parts of your telescope. If you have one of the equatorial models or one of the altazimuth models, read all sections that pertain to your telescope.

WARNING—NEVER LOOK AT THE SUN WITH YOUR TELESCOPE OR ITS FINDERSCOPE. PERMANENT AND IRREVERSIBLE EYE DAMAGE MAY RESULT AS WELL AS DAMAGE TO YOUR TELESCOPE.

HOWEVER, YOU MAY ENJOY LOOKING AT THE SUN IF YOU HAVE A SAFE METHOD OF DOING SO—A SOLAR FILTER. IF USING A SOLAR FILTER, MAKE SURE THE FINDERSCOPE IS COVERED.

2. TELESCOPE ASSEMBLY

Please refer to Figure 1 (and the identifying parts list) as you assemble the telescope.

The telescope and all items are packed in one box. Included are:

Model # 31031

- Telescope Optical Tube
- German Equatorial Mount
- Adjustable Wood Tripod
- 5x24 Finderscope and Bracket
- Counterweight Shaft and Counterweight
- Tripod Accessory Tray
- Declination Cable
- Right Ascension Cable
- 8mm Eyepiece - 1¼" (88x)
- 12.5mm Eyepiece - 1¼" (56x)
- Barlow Lens - 2x - 1¼"

Model #31046

Same as #31031 but the eyepieces supplied are:

- 20mm Eyepiece - 1¼" (50x)
- 6mm Eyepiece - 1¼" (167x)

Model # 31030

- Telescope Optical Tube
- Altazimuth Mount
- Adjustable Wood Tripod
- 5x24 Finderscope and Bracket
- Tripod Accessory Tray
- Altitude Slow Motion Rod
- 8mm Eyepiece — 1¼" (88X)
- 12.5mm Eyepiece — 1¼" (56x)

Model # 31030 - WOS

Same as #31030 but the eyepieces supplied are:

- 20mm Eyepiece — 1¼" (35x)
- 6mm Eyepiece — 1¼" (117x)

A. Locate the German equatorial mount or altazimuth mount and the tripod legs along with the tripod mounting hardware and the tripod accessory tray.

1. Lie the tripod head (#11) on its side. Attach the three tripod legs (#15) one by one to the tripod head with the bolts and wing nuts (#20). Do not overtighten the bolts but just make them lightly finger tight. Remember to have each tripod leg in the right orientation with the tripod tray bracket (#14) facing inward.
2. Next, put the bolts and wing nuts in the bottom of the tripod legs through the holes for the height adjustment you want. We suggest you keep it at the lowest height for assembly (you can raise it later if you wish) and for maximum rigidity.

NOTE—this may have been assembled at the factory.

3. **a)** Attach the equatorial mount (#10) to the tripod as shown in Figure 1.
b) Attach the altazimuth mount, as shown in Figure 2, to the tripod.
4. Now set the tripod with the equatorial mount attached in the standing position by spreading the legs apart far enough for the tripod accessory tray (#14) to fit.
5. You are now ready to install the tripod accessory tray (#14). The tripod tray bracket fits into slots in the bottom of the tray (use the holes on the ends of the brackets). Use the bolts and wing nuts to attach each bracket to the tray.
6. Tighten all bolts and wing nuts to ensure proper stability.

B. Before proceeding further, locate knobs #19 and #22 and tighten them finger tight after orienting the mount as illustrated in Figure 1 — for equatorial mounts only.

1. Locate the declination cable holder (where #7 fits on). Locate the declination cable (the shorter of the two cables) and attach the cable (#7) to the cable holder by tightening the thumb screw on the cable end. The thumb screw should be tightened down hard on the flat surface of the cable holder after backing off the cable about 1/4" from being fully engaged. This method helps ensure there is no slippage when using the cable.
2. You may reverse the position orientation of the Declination cable to suit your preference if desired.
3. Locate the right ascension cable holder (where #21 fits on). Locate the right ascension cable (#21) and attach it the same way as the declination cable was attached in the last section.
4. Slide the counterweight shaft (#13) through the counterweight (#12). Use the counterweight lock to lock the counterweight in place. By holding the counterweight in one hand, thread the counterweight shaft clockwise into the equatorial mount as shown in figure 1.

C. **a)** Now you are going to put the telescope optical tube (#1) onto the equatorial mount (#10).

1. Remove the nuts from the tube mounting screws (#23). Put the bolts from the tube, as shown in Figure 1 (#23), into the bracket at the top of the mount and tighten the nuts.

- b) Now you are going to put the telescope optical tube onto the altazimuth mount — see Figure 2.
1. Slide the slow motion rod through the adjustment hole.
 2. Place the telescope tube inside the altazimuth mount.
 3. Insert the altitude adjustment screws (star shaped handles) through the mount and thread into the sides of the telescope.
 4. Remove the lens cap from the telescope.

D. To attach the finderscope:

1. Remove the nuts from the studs where the finderscope will mount.
2. Mount the finderscope bracket by mounting the bracket over the studs protruding from the tube and tightening it down with the supplied nuts. Additional nuts may be included with the bracket and these should be discarded.
3. Slide the finderscope (#3) into the bracket and hold it in place by hand tightening the adjustment screws.

- E. Put a low power eyepiece (#4) into the eyepiece adapter and tighten the thumb screw to hold it in place.

3. TELESCOPE OPERATION — GETTING SET UP

For Equatorial Models — A thru F / For Altazimuth Models — F thru G

- A. Loosen the polar axis knob (near #9) with one hand while holding the equatorial mount with the other hand. Look at the latitude scale (#22) and move the mount to the latitude of your location and then tighten the polar axis knob. This only has to be done once unless you take the telescope to a different location. For example, Los Angeles, California is located at about 34°. If you do not know your latitude, it can be found on most road atlases of your area.
- B. To change the direction your telescope is pointing:
1. To move the telescope in declination (north/south) there are two options. For large and quick movements, release the declination knob (near #8) and then tighten the knob when you are near the position you want. For very small movements and fine adjustments, use the declination cable (#7). The declination cable has a range of about 30° and if you come to the stop at the end then overshoot your target by releasing the declination knob and move the telescope in declination. Then tighten the knob and reverse the direction of the declination cable. Do not try to force movement when the declination cable has reached the stop.
 2. To move the telescope in right ascension (east/west) there are two options. For large and quick movements, release the right ascension knob (near #9) and then tighten the knob when you are near the position you want. For very small movements and fine adjustments, use the right ascension cable (#21).

- C. The telescope should be properly balanced in order for it to move smoothly in both axes. Proper balance is essential if using an optional motor drive for accurate tracking.
1. To balance the right ascension axis, move the counterweight shaft so it is parallel (horizontal) to the ground. Slowly release the right ascension knob (near #9) and see if the optical tube moves. If the optical tube moves, then slide the counterweight up or down the counterweight shaft until the optical tube remains stationary in the parallel position to the ground. When this happens, make sure the counterweight lock is tight.
- D. To quickly move the telescope around horizontally
1. Loosen the horizontal adjustment knob (#19), move the telescope to the position desired and then tighten the knob.
- E. Preparation for astronomical observing requires that you:
1. Orient the telescope so that the right ascension (polar) axis is pointing as close to true north as possible. Use a magnetic compass if you are not sure which way north is.
 2. Make sure the mount is level. A carpenter's level may be helpful.
 3. Recheck all hardware and knobs to make sure all are tight.
- F. To focus the telescope and align the finderscope:
1. Remove the front lens cover (#5).
 2. With a low power eyepiece tight in the eyepiece adapter (with its lens cover removed), position the telescope tube to look at any object about one mile or further away during the day. Put the object in the center of the field. To focus, turn the focusing knob (#2) until your chosen object is in sharp focus. Remember to use outdoors only as you should not look through windows which may distort the image.
 3. Look through the finderscope (with its lens covers removed). If the object being observed is not visible in the finderscope or is not in the center of the finderscope crosshairs, then you need to align the finderscope. Use the finderscope adjustment screws to align the finderscope with the main telescope by tightening and loosening these screws until the object is centered on the crosshairs. Once the finderscope is aligned with the main telescope, it makes it easy to find celestial objects. You find the desired object in the finderscope first (since it has a wide field) and then look at the narrow field but much more powerful main telescope for detailed views.
 4. If the image in the finderscope is not sharp, then turn the finderscope eyepiece until the image is sharp.
 5. Do not be alarmed when you look through the finderscope and telescope and the object is upside down and reversed left to right. This is normal with an astronomical telescope.
- G. Preparation for astronomical observing with the altazimuth models.
1. All that is necessary is to recheck all hardware and knobs to make sure all are tight.

4. UNDERSTANDING THE SKY

A. *The Celestial - Coordinate System.*

The celestial-coordinate system is an imaginary projection of the Earth's geographical coordinate system onto the celestial sphere which seems to turn overhead at night. This celestial grid is complete with equator, latitudes, longitudes and poles.

The Earth is in constant motion as it rotates on its axis. Actually the celestial-coordinate system is being displaced very slowly with respect to the stars. This is called precession and is caused by gravitational influences from the Sun, Moon and other celestial bodies.

The celestial equator is a full 360° circle bisecting the celestial sphere into the northern celestial hemisphere and the southern celestial hemisphere. Like the Earth's equator, it is the prime parallel of latitude and is designated 0°.

The celestial parallels of latitude are called "coordinates of declination (Dec.)", and like the Earth's latitudes they are named for their angular distances from the equator. These distances are measured in degrees, minutes and seconds of arc. There are 60 minutes of arc in each degree, and 60 seconds of arc in each arc minute. Declinations north of the celestial equator are "+" and declinations south are "-". The north pole is +90 and the south pole is -90.

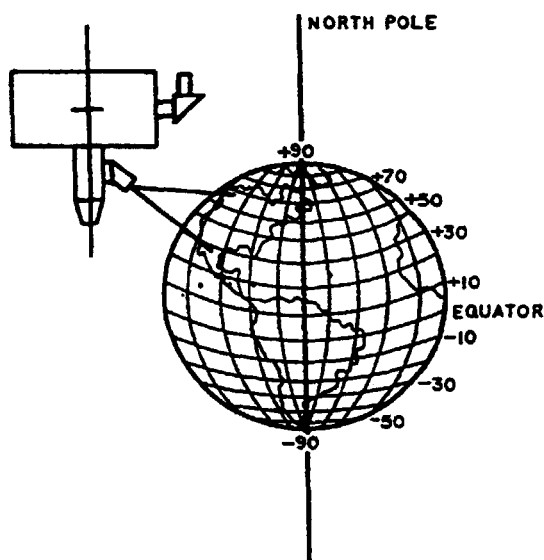

Figure 2

coordinates denote locations on the celestial sphere, because this makes it easier to tell how long it will be before a particular star will cross a particular north-south line in the sky. So, R.A. coordinates are marked off in units of time eastward from an arbitrary point on the celestial equator in the constellation Pisces. The prime R.A. coordinate which passes through this point is designated "0 hours 0 minutes 0 seconds". We call this reference point the vernal equinox where it crosses the

The celestial meridians of longitude are called "coordinates of right ascension (R.A.)", and like the Earth's longitude meridians they extend from pole to pole. There are 24 major R.A. coordinates, evenly spaced around the 360° equator, one every 15°. Like the Earth's longitudes, R.A. coordinates are a measure of time as well as angular distance. We speak of the Earth's major longitude meridians as being separated by one hour of time because the Earth rotates once every 24 hours (one hour = 15°). The same principle applies to celestial longitudes since the celestial sphere appears to rotate once every 24 hours. Right ascension hours are also divided into minutes of arc and seconds of arc, with each hour having 60 minutes of arc and each arc minute being divided into 60 arc seconds.

Astronomers prefer the time designation for R.A. coordinates even though the

celestial equator. All other coordinates are names for the number of hours, minutes and seconds that they lag behind this coordinate after it passes overhead moving westward.

Given the celestial coordinate system, it now becomes possible to find celestial objects by translating their celestial coordinates using telescope pointing positions. For this you use setting circles (if you have the Firstscope 76 EQ - equatorial mount models) for R.A. and Dec. to find celestial coordinates for stellar objects which are given in star charts and reference books.

B. Polar Alignment (For Equatorial Model Only)

To make tracking the stars easier, rough polar alignment is required.

1. The right ascension (polar) axis should be pointed towards the North Pole (see the illustration below).
2. The equatorial mount should be level.
3. Your latitude should be set (see 3.A).

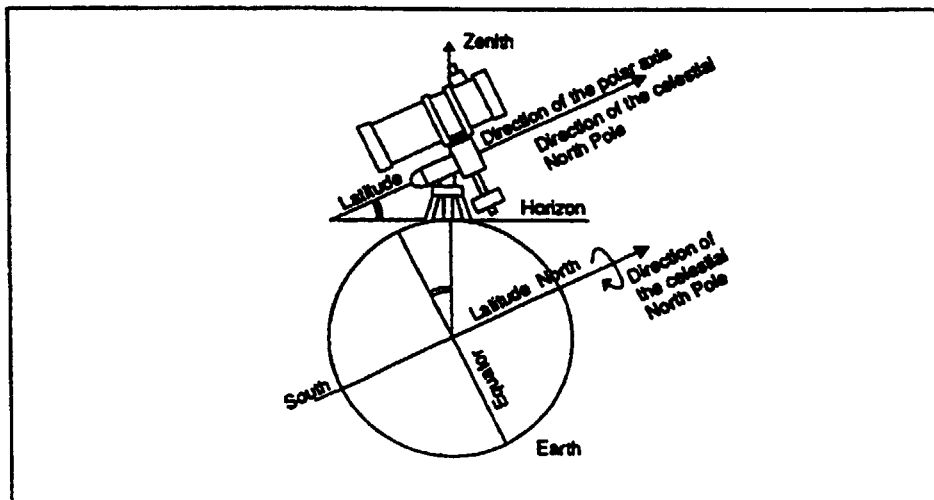
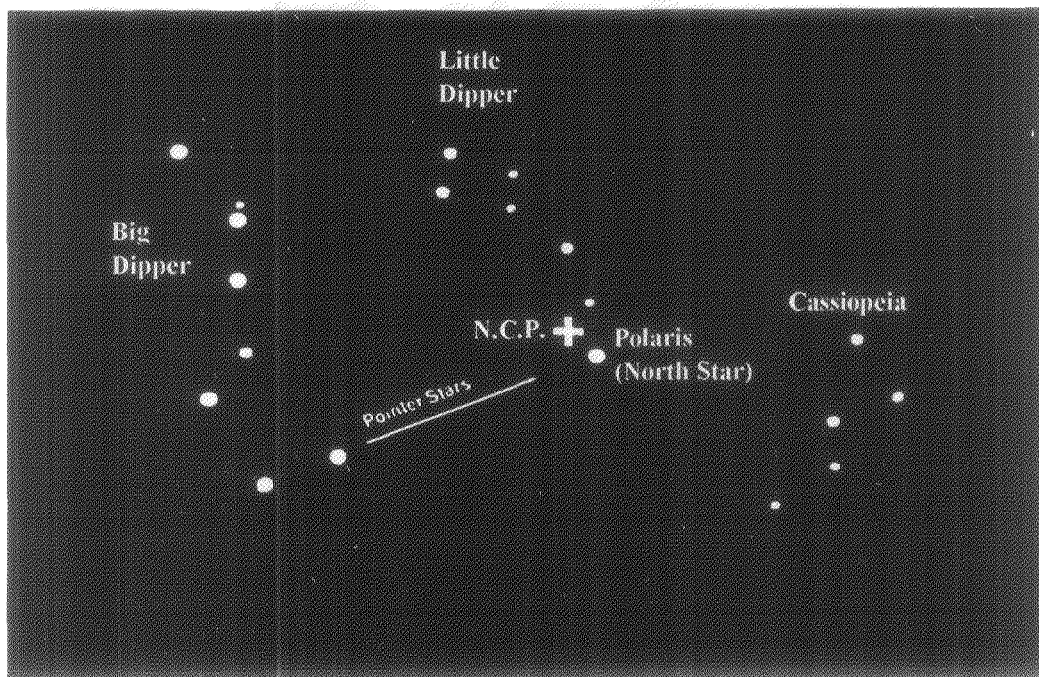

Figure 3

4. See the illustration below if you are not sure where the North Pole is located.



5. To find astronomical objects, you will now mainly use the right ascension axis as the polar alignment virtually eliminates needed adjustments in the declination axis.

To track objects continuously, adjustments will be made with the right ascension cable.

When using the telescope, all objects in the sky will slowly drift out of the field of view unless you manually make corrections with the right ascension cable.

6. The above method of polar alignment is adequate for casual observing. More precise methods of polar alignment are available and most astronomy texts or telescope books describe the procedures.
7. If you look at the North Star after this polar alignment procedure, your declination setting circle (#8) should read 90° (the actual is 89.2°).

C. *Finding Objects with the Altazimuth Mount (For Altazimuth Models only)*

1. Loosen the altitude locks on the sides of the telescope tube and the azimuth lock on the base of altazimuth mount, then move the telescope in the desired direction.
2. Look through the finderscope and pan the telescope until the object appears in the field of view. Once it's in the field, tighten the altitude and azimuth locks.
3. To center the object in the finderscope, use the fine adjustment ring on the altitude slow motion rod assembly.

D. *Using the Setting Circles (For Equatorial Model only)*

Setting Circles are dials (or gauges) for right ascension and declination that allow you to locate celestial objects easily from their coordinates as listed in a star chart or atlas.

1. The declination setting circle is scaled in degrees and the right ascension setting circle is incremented in minutes. The circles will get you close to your target but not directly on it. Also, the accuracy of your polar alignment will affect how accurate your setting circles read.
2. The declination setting circle is factory set and should not need any adjustment if it reads accurately as noted in 4.B (7).
3. The right ascension setting circle (#9) must be aligned. Choose a bright and easy to find star in a star chart and note the coordinates (right ascension and declination). Find the star and center it in the finderscope and then in the telescope. Now, rotate the right ascension circle to match the coordinates of the star with the indicator mark.
4. The right ascension setting circle does not move as the telescope moves in right ascension and thus it must be aligned each time you want to use it to find a new object. However, you do not need to use a bright star each time but you can use the object you are currently observing.
5. Now, using a star chart or atlas you can find numerous objects. First move the telescope in declination to the correct declination coordinate. Then move the telescope in right ascension until the indicator points to the correct coordinate.
6. After moving the telescope to the correct celestial coordinates, look through the finderscope to see if you have located the object and center the object. Then, look through the telescope (with a low power eyepiece) and the object should be there.

On fainter objects, they may not be visible in the finderscope and thus you should gradually sweep the telescope around (with the right ascension and declination cables) until the object is visible.

5. MAGNIFICATION (POWER)

The magnification (or power) of a telescope is variable depending upon the focal length of the eyepiece being used along with the focal length of the telescope.

- A. If you purchased one of the 76mm diameter models, your telescope has a focal length of 700mm.

To calculate the magnification we use the following formula:

$$\text{Magnification} = \frac{FL(\text{telescope})}{FL(\text{eyepiece})}$$

where FL(telescope) is the focal length of the telescope and FL(eyepiece) is the focal length of the eyepiece. So, if you use an 8mm eyepiece your magnification is $700/8 = 88x$.

There are numerous optional eyepieces that are available to expand your range of magnification. There are various types of eyepieces of varying quality to choose from.

- B. Magnification through the telescope has its limits. These limits are determined by the laws of optics and the nature of the human eye. The maximum usable power is equal to 60 times the aperture of the telescope (in inches). So your telescope has a maximum useful power of 180x (3" x 60). If you purchased the 114mm model (4.5") then your maximum useful power is 270x (4.5" x 60). You can create power higher than this limit but the images will be dark and blurred with poor contrast.

The maximum power is used only under ideal conditions which are not common. Most of your viewing will be done in the range of 25x to 120x. Higher powers are used mainly for lunar and planetary observing under ideal seeing conditions.

- C. Your telescope (if you have the equatorial mount model) also has supplied as standard equipment a 2x Barlow Lens - 1¼".
1. To use the Barlow Lens, insert the smaller barrel end into the focuser and tighten the thumb screw. Then insert a 1¼" eyepiece in the other end of the Barlow Lens and tighten the thumb screw.

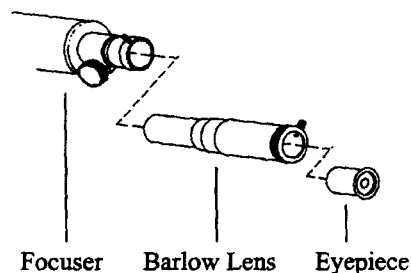

If you have one of the altazimuth models, you can purchase a Barlow Lens as an optional accessory.

6. TELESCOPE OPERATION — ASTRONOMICAL OBSERVING

After you have read and followed the instruction manual to this point, the telescope is set up and you are ready to begin your observing adventure.

To enable you to find objects you should have a set of Star Charts or a Planisphere. The location of the planets may appear in local newspapers.

- A. The Moon is an awesome first object to observe. The best observing occurs during the partial phases as a full Moon is too bright.

At low power you can see the complete Moon and at high powers you can see lunar details such as mountain ranges, craters and rills.

- B. Five of the planets are easy targets for your telescope.

See Jupiter with its great red spot, study the cloud bands and watch its moons shuttle back and forth.

Study Saturn and its splendid ring structure.

Observe Mars and see its polar cap.

Watch Venus and Mercury as they go through their moon-like phases.

- C. **The Sun is quite safe to view if you utilize a proper solar filter. You can detect and watch the ever-changing sunspot activity.**

Remember to cover the finderscope when using a solar filter.

D. Deep-Sky objects (those outside our solar system) offer a lifetime of observing. There are hundreds of objects within the realm of your telescope including open and closed star clusters, planetary and diffuse nebulae, galaxies, double stars and occasional comets. The amount of detail you can see is dependent on your observing site (dark sky rural locations are best), atmospheric conditions, brightness of the object, collimation and your observing experience.

7. TELESCOPE MAINTENANCE

With proper care your telescope should rarely need any maintenance work.

- A. When not in use, always replace all lens covers to keep dust and contaminants off the optical surfaces.
- B. A small amount of dust on any optical surface is ok. If the dust builds up then use a can of compressed air and then a camel's hair brush to remove the dust.
- C. If the mirrors need cleaning, they should be cleaned by a professional. Either have your instrument serviced by a telescope repair facility or return it to the factory.
- D. Collimation or alignment of the optical system is done at the factory before shipment.
 - 1. If your telescope has received very rough handling during transport or is dropped, it may need collimation.

To check if your telescope is in collimation the sketch below will help you. If you look into the eyepiece adapter (without an eyepiece) at the top of the focuser, this is what you should see. If the reflection of your eye is off center, then collimation is necessary.

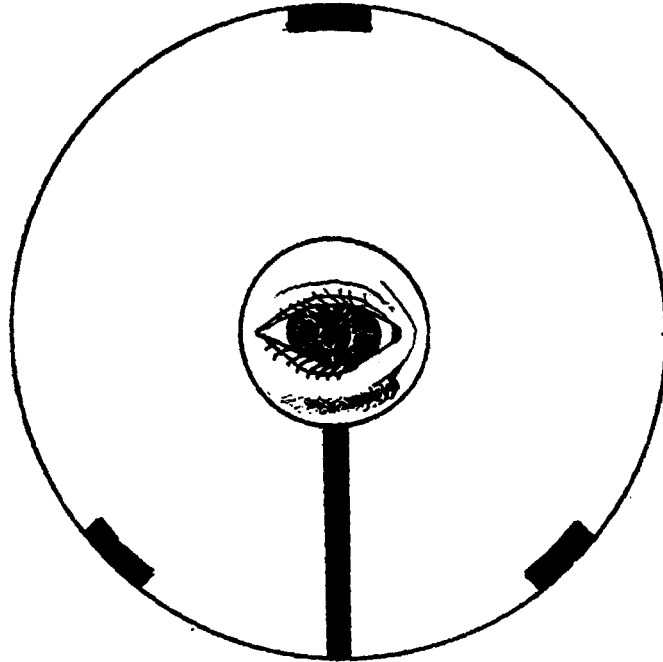

2. If your telescope is out of collimation, the best way to re-collimate it is with a good collimation tool. Celestron offers a Newtonian Collimation Tool (#94183) with detailed instructions that make it an easy chore.

SPECIFICATIONS

	#31030 \ #31030-WOS \ #31031	#31046
Optical System:	Newtonian Reflector	Newtonian Reflector
Aperture:	76mm (3")	114mm (4.5")
Focal Length:	700mm	1000mm
F/ratio:	f/9.2	F/8.8
Focuser	1¼" Rack and Pinion	1¼" Rack and Pinion
Standard Oculars (or Eyepieces)	1¼" size — the focuser also has an adapter to allow usage of .96" size oculars.	1¼" size — the focuser also has an adapter to allow usage of .96" size oculars.

NOTE: Specifications are subject to change without notice.

9. OPTIONAL ACCESSORIES

Celestron International offers a wide assortment of optional accessories to expand your interests.

- A. Sky Maps (#93722) - Invaluable when learning the night sky. They include all the constellations with the brighter deep-sky objects. On the front cover is a rotating planisphere which indicates when specific constellations are visible.
- B. Flashlight - LED (#93588) - Uses a red LED to allow reading star maps and locating telescope accessories and controls without ruining your night vision.
- C. Eyepieces - A whole assortment of 1¼" eyepieces are available to give you a wide range of magnifications.
- D. Collimation Tool for Newtonians (#94183) - A helpful aid to collimating your telescope. Provided is a simple tool and detailed instructions.
- E. Planisphere & Planet Guide (#93720) — Simple and easy to use to find your way around the sky. Available in various latitude ranges — 30° (20 - 40°), 40° (30 - 50°), 50° (40 - 60°).
- F. Star Pointer (#51630) — A valuable guide (finderscope) to help locate objects via a red-dot projection target. Easy to mount and use.
- G. Other - Numerous Accessories are available. See the Celestron Accessory Catalog (#93685) or ask your Celestron dealer for details.

CELESTRON ONE YEAR LIMITED WARRANTY

- A. Celestron International (CI) warrants this telescope to be free from defects in materials and workmanship for one year from the date of purchase. CI will repair or replace such product or part thereof which, upon inspection by CI, is found to be defective in materials or workmanship. As a condition to the obligation of CI to repair or replace such product, the product must be returned to CI together with proof-of-purchase satisfactory to CI.
- B. The Proper Return Authorization Number must be obtained from CI in advance of return. Call Celestron at (310) 328-9560 to receive the number to be displayed on the outside of your shipping container.

All returns must be accompanied by a written statement setting forth the name, address, and daytime telephone number of the owner, together with a brief description of any claimed defects. Parts or product for which replacement is made shall become the property of CI.

The customer shall be responsible for all costs of transportation and insurance, both to and from the factory of CI, and shall be required to prepay such costs.

CI shall use reasonable efforts to repair or replace any product covered by this limited warranty within thirty days of receipt. In the event repair or replacement shall require more than thirty days, CI shall notify the customer accordingly. CI reserves the right to replace any product which has been discontinued from its product line with a new product of comparable value and function.

This warranty shall be void and of no force of effect in the event a covered product has been modified in design or function, or subjected to abuse, misuse, mishandling or unauthorized repair. Further, product malfunction or deterioration due to normal wear is not covered by this warranty.

CI DISCLAIMS ANY WARRANTIES, EXPRESS OR IMPLIED, WHETHER OF MERCHANTABILITY OF FITNESS FOR A PARTICULAR USE, EXCEPT AS EXPRESSLY SET FORTH HEREIN.

THE SOLE OBLIGATION OF CI UNDER THIS LIMITED WARRANTY SHALL BE TO REPAIR OR REPLACE THE COVERED PRODUCT, IN ACCORDANCE WITH THE TERMS SET FORTH HEREIN. CI EXPRESSLY DISCLAIMS ANY LOST PROFITS, GENERAL, SPECIAL, INDIRECT OR CONSEQUENTIAL DAMAGES WHICH MAY RESULT FROM BREACH OF ANY WARRANTY, OR ARISING OUT OF THE USE OR INABILITY TO USE ANY CI PRODUCT. ANY WARRANTIES WHICH ARE IMPLIED AND WHICH CANNOT BE DISCLAIMED SHALL BE LIMITED IN DURATION TO A TERM OF ONE YEAR FROM THE DATE OF ORIGINAL RETAIL PURCHASE.

Some states do not allow the exclusion or limitation of incidental or consequential damages or limitation on how long an implied warranty lasts, so the above limitations and exclusions may not apply to you.

This warranty gives you specific legal rights, and you may also have other rights which vary from state to state.

CI reserves the right to modify or discontinue, without prior notice to you, any model or style telescope.

If warranty problems arise, or if you need assistance in using your CI product, contact:

Celestron International
Customer Service Department
2835 Columbia Street
Torrance, CA 90503
Tel. (310) 328-9560
Fax. (310) 212-5835
Monday-Friday 8AM-4PM PST

This warranty supersedes all other product warranties.

NOTE: This warranty is valid to U.S.A. and Canadian customers who have purchased this product from an Authorized CI Dealer in the U.S.A. or Canada. Warranty outside the U.S.A. and Canada is valid only to customers who purchased from a CI International Distributor or Authorized CI Dealer in the specific country and please contact them for any warranty service.

Printed in China 0298