

***CELESTRON***<sup>®</sup>

- NOVICE 50 • NOVICE 60
- FIRSTSCOPE 60 SHORT
- FIRSTSCOPE 60
- FIRSTSCOPE 60 DELUXE
- FIRSTSCOPE 60 DLX-AL

**REFRACTING TELESCOPES  
ALTAZIMUTH MOUNTS**

---

**INSTRUCTION MANUAL**

**Models # 21055, 21055-DX, 21055-DX-AL**

**Models # 21051-W, 21058 and 21054**

---

## INTRODUCTION

---

Congratulations on your purchase and welcome to the Celestron world of amateur astronomy. Some of the terms and parts described in these instructions may be new to you, so a few commonly used terms you'll want to be familiar with are defined below.

**Altazimuth mount** - the simplest type of mount, with two motions: altitude (up and down) and azimuth (side-to-side). "Mount" refers to the part of the telescope that supports the tube, which carries all the telescope's optics.

**Altitude lock** - allows the telescope tube to be locked into place once a focused image has been set up, by tightening the two screws on the outside of the altazimuth mount.

**Aperture** - the diameter (in millimeters) of the objective lens. The larger the aperture, the more light the telescope collects. More light creates a brighter, clearer image.

**Focal length** - the distance from the optical center of the lens to the point where the incoming light rays converge, creating a clear, focused image.

**Objective lens** - the front lens of the telescope. It gathers incoming light to create a sharply focused image.

**Refracting telescope** - a long, thin tube where light passes in a straight line from the front objective lens directly to the eyepiece at the opposite end of the tube.

This telescope is a classical refracting telescope with a 50 or 60mm objective lens. Its light gathering power (60mm) is about 75 times that of the unaided human eye and 50 times that for the 50mm telescopes. With this telescope you'll be able to study craters on the moon, watch Jupiter's moons as they circle the gas giant, view Saturn's rings and the phases of Venus. You'll also be able to observe bright double stars. The 60mm telescopes can also be used to observe the brighter nebulae and large star clusters. But your Celestron telescope is not limited to astronomical viewing. It can also be used for terrestrial viewing of the world around you, such as observing wildlife and distant views.

First, you need to take the time to familiarize yourself with the parts of your telescope, then assemble it, following the easy instructions provided. Next, read over the operating instructions and become familiar with how your telescope works, to prepare for hours of viewing enjoyment.

### **CAUTION: READ THIS SECTION BEFORE USING YOUR TELESCOPE**

Your Celestron telescope is designed to give you hours of fun and rewarding observing. However, there are a few things to be aware of before using your telescope that will ensure your safety and protect your equipment.

**NEVER** look directly at the sun with the naked eye or with a telescope. Never point your telescope at the sun unless you're using the proper solar filter. Permanent and irreversible eye damage may result.

**NEVER** use your telescope to project an image of the sun onto any surface, or use an eyepiece solar filter or a Herschel wedge. Internal heat build-up can damage the telescope and/or any accessories that may be attached to it.

**NEVER** leave your telescope unsupervised, especially when children are present. This also holds true for adults who may not be familiar with the correct operating procedures for your telescope.

**ALWAYS** cover the finderscope when using your telescope with a correct solar filter. Although small in aperture, this instrument has enough light gathering power to cause permanent and irreversible eye damage. The image projected by the finderscope is hot enough to burn skin or clothing.

---

## THE REFRACTOR TELESCOPE

---

Your telescope is a classical, two element refracting telescope that comes on an altazimuth mount. This section instructs you on the proper assembly and use of your Celestron telescope, which is shipped in one box, containing

all the parts you need to assemble it. Unpack and lay out all of the parts in a large, clear area where you'll have room to work. Keeping track of the parts, use the list below and the telescope diagram to confirm you have, and can identify each part.

- a. Three tripod legs, with one accessory tray bracket mounted on each leg
- b. Tripod accessory tray
- c. Altazimuth mount
- d. Telescope tube including:
  - 1. Lens shade; front and rear lens caps (pre-assembled)
  - 2. Rack and pinion focuser (pre-assembled)
  - 3. Altitude slow motion rod assembly (Firstscope 60's only)
  - 4. Finderscope/bracket assembly
- e. Visual accessories including:
  - See specifications on page 7
- f. Assembly hardware
  - 1. Tripod leg bolt pack - three long screws with wing nuts and washers
  - 2. Accessory tray bolt pack - three small screws with wing nuts and washers
  - 3. Tripod adjustment bolt pack - three large wing nut screws
  - 4. One flat, triangular metal screwdriver

---

### **Setting Up The Tripod (the same for the wood or aluminum models)**

---

To set up the tripod, locate the altazimuth mount, the tripod legs and the tripod bolt pack.

- 1. Extend the center portion of each of the three tripod legs down 6-8".
- 2. Open the tripod adjustment bolt pack. Use the three wing nut screws to secure each of the extended legs by threading these screws through the holes in the brackets at the bottom of each leg. This is important. If you do not extend the legs now, you won't be able to once the tripod head is assembled. Fine tuning of tripod height can be done later, and the wing nuts can be adjusted to secure the telescope at a desirable height.
- 3. Orient the three tripod legs so the brackets that hold the accessory tray are on the inside.
- 4. Slide the two top portions of the tripod leg around the flange on the altazimuth mount, so the flange is secured between them.
- 5. Remove the wing nut and one washer from the screw.
- 6. Slide the screw through the tripod leg and flange, until the screw extends out the other side.
- 7. Slide the washer and wing nut over the screw and tighten. This can be left slightly loose, to allow for positioning the legs later, when attaching the accessory tray.
- 8. Repeat this process for the remaining two legs. Now the tripod will stand by itself.

---

### **Attaching the Accessory Tray**

---

Start by locating the accessory tray and bolt pack for the accessory tray.

- 1. Remove the wing nut and one washer from each screw.
- 2. Slide one corner of the accessory tray over the bracket hanging from the tripod leg. Make sure the tray is placed over the tip of the bracket, so the bracket doesn't cover the holes cut into the accessory tray, allowing for full use.
- 3. Insert a screw—with washer—down through the accessory tray and bracket.
- 4. Slide the washer and wing nut over the end of the screw. Tighten the screw completely.
- 5. Repeat this process for the remaining two corners of the accessory tray.

---

### **Installing the Telescope Onto the Mount**

---

- 1. Slide the altitude slow motion rod through the adjustment hole.
- 2. Place the telescope tube inside the altazimuth mount.
- 3. Insert the altitude adjustment screws (star shaped handles) through the mount and thread into the sides of the telescope.
- 4. Remove the lens cap from the telescope.

---

## Attaching the Finderscope

---

1. Remove the two (2) small, silver thumbscrews located at the back of the telescope tube.
2. Place the finderscope bracket over the two holes in the telescope tube, lining up the holes on the finderscope bracket with those in the telescope tube. The finderscope should be "leaning back" when installed correctly.
3. Insert the thumbscrews through the finderscope bracket and thread them into the telescope tube.
4. Remove the front and rear lens caps from the finderscope.

---

## Attaching the Eyepieces

---

1. Remove the caps from the focuser (at the end of the telescope tube) and the diagonal. The cap for the diagonal is at the center of the top cover.
2. Insert the chrome end of the diagonal into the focuser.
3. Lock into place by tightening the set screws on the focuser.
4. Remove caps from the eyepiece (ocular) and place it into the diagonal. Lock it into place with the set screw.

**NOTE:** Your telescope comes equipped with a hybrid diagonal for use with either .96" or 1 $\frac{1}{4}$ " eyepieces. The eyepiece adapter comes set up for use with a .96" size eyepieces. The inner bushing of the adapter is easily removed so that 1 $\frac{1}{4}$ " eyepieces can be used (see diagrams below).

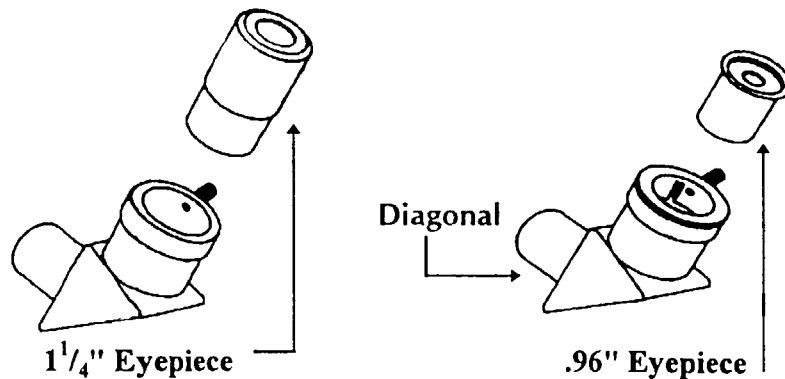

---

## Installing a Barlow Lens

---

Some models come standard with a 2x Barlow lens, and Celestron has a variety of optional Barlow lenses that can be used with your telescope.

The best way to use the Barlow Lens is as follows:

First, you remove the diagonal from the focuser and insert the Barlow lens directly into the end of the focuser, then put the diagonal in the Barlow lens, and the eyepiece into the diagonal. Remember that lower powers have sharper and brighter images. Higher powers can be used when seeing conditions are very good.

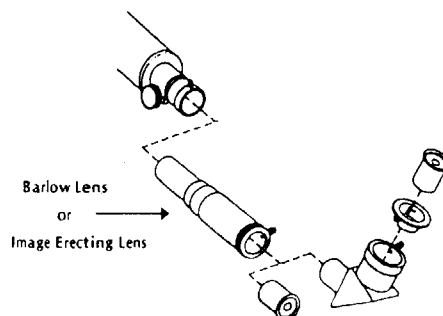

Celestron's Barlow lenses double the magnifying power of your eyepieces by increasing their effective focal length. For example, an 18mm eyepiece mounted on a 2x Barlow lens would have the magnifying power of a 9mm eyepiece. It's like having two eyepieces in one — an economical way to increase your range of magnifications without buying new eyepieces. Please see Celestron's Accessory Catalog #93685 for more information.

**NOTE:** Some models come standard with a 1.5x erecting eyepiece (#21055), primarily for daytime terrestrial viewing. This eyepiece corrects the image you see in your telescope, so that it's both right side up and corrected from left to right. Without this eyepiece, the image you see is reversed from left to right, when using the standard diagonal. To use the erecting eyepiece, remove the diagonal and insert the erecting eyepiece directly into the focuser (see diagram above). Then use a low power .96" eyepiece such as the 20mm, inserting it directly into the erecting eyepiece.

---

### Aligning the Finderscope

---

1. Point the telescope at a stationary object (e.g., a stop sign) at least 100 yards away. Looking through the eyepiece (make sure all caps have been removed), focus on the object seen in the main telescope by turning either of the focus knobs on the telescope tube.
2. Carefully center the object in your field of view.
3. Look through the finderscope at the object. If the object needs to be centered, use the three screws holding the finderscope in its bracket to accomplish this. Loosen and adjust the screws, two at a time, until the cross hairs are fixed on the object centered in the main telescope. Tighten the set screws and check alignment again.

---

### Finding Objects

---

1. Loosen the altitude locks on the sides of the telescope tube and the silver azimuth lock on the base of the altazimuth mount, then move the telescope in the desired direction.
2. Look through the finderscope and pan (up/down and left/right) the telescope until the object appears in the field of view. Once it's in the field, tighten the altitude and azimuth locks.
3. To center the object in the finderscope, use the fine adjustment ring on the altitude slow motion rod assembly - for Firtscope 60 models only. For the Novice telescopes, use the fine adjustment ring on the eyepiece of the finderscope.

---

### Focusing

---

1. Once you have found an object in the telescope, turn the focusing knob until the image is sharp.
2. To focus on an object that is nearer than your current target, turn the focusing knob toward the eyepiece (i.e., so that the focusing tube moves away from the front of the telescope). For more distant objects, turn the focusing knob in the opposite direction.
3. To achieve a truly sharp focus, never look through glass windows or across objects that produce heat waves, such as asphalt parking lots.

---

### Image Orientation

---

1. When observing with a diagonal, the image will be right side up, but reversed from left to right.
2. When observing straight through, with the eyepiece inserted directly into the telescope, the image will be inverted. Also, the image in the finderscope is inverted (which is normal).

---

### Using the Altitude Slow Motion Rod Assembly

---

This assembly is used to elevate or lower (up or down) the vertical aim of the telescope tube in very small increments. After making rough adjustments, then tighten the thumb screw which locks the rod to the mount. Then, turn the thumbwheel to make fine altitude (up/down) adjustments.

---

## Magnification

---

The magnification (or power) of a telescope varies depending upon the focal length of the eyepiece being used and the focal length of the telescope.

For example, we will use the Firstscope 60 telescopes that have a focal length of 700mm and come with a 20mm eyepiece. To calculate magnification, use the following formula, in which FL = focal length:

$$\text{Magnification} = \frac{\text{FL}(\text{telescope}) \text{ in mm}}{\text{FL}(\text{eyepiece}) \text{ in mm}}$$

Therefore, if you use the 20mm eyepiece your magnification is  $700/20 = 35x$ . The same formula can be applied to any of your eyepieces.

Celestron offers numerous optional eyepieces to expand your range of magnification. Eyepieces come in barrel diameters of .96" and 1 1/4". In general, 1 1/4" eyepieces are of a higher optical quality and give you sharper images along with a wider field of view and better eye relief.

Magnification through the telescope has its limits. These limits are determined by the laws of optics and the nature of the human eye. The maximum usable power (with sharp images) is equal to 60 times the aperture of the telescope (in inches). So, with a 60mm telescope it has a maximum very useful power of 142x ( $2.3622" \times 60$ ). Most of your viewing will be done in the range of 30x to 120x. Higher powers are used mainly for lunar and sometimes planetary observing where you can greatly enlarge the image. The images at extremely high powers like 200x to 675x magnify the image but remember that the contrast will be very low and the image somewhat blurred due to the super power. For the brightest images with the most contrast, use the lower powers with a smaller image scale.

---

## Optional Accessories

---

Celestron offers a full line of optional accessories for your Novice or Firstscope telescope. Please consult the Celestron Accessory Catalog (#93685) for a complete description. One of the best things you can buy to get started with this hobby is a set of good star charts like Celestron's Sky Maps (#93722).

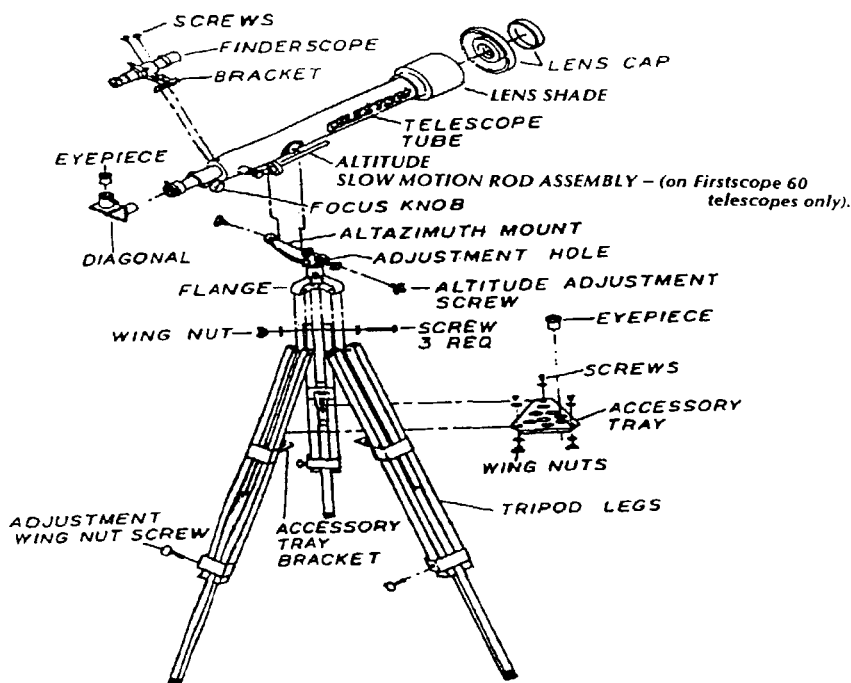

## SPECIFICATIONS

|                                                                        | 21051-W                 | 21058                  | 21054                 | 21055                 | 21055-DX                | 21055-DX-AL           |
|------------------------------------------------------------------------|-------------------------|------------------------|-----------------------|-----------------------|-------------------------|-----------------------|
| <b>Aperture (Diameter) of Lens (mm)</b>                                | 50                      | 60                     | 60                    | 60                    | 60                      | 60                    |
| <b>Focal Length (mm)</b>                                               | 625                     | 700                    | 900                   | 700                   | 700                     | 700                   |
| <b>Focal Ratio (f#)</b>                                                | 12.5                    | 11.7                   | 15.0                  | 11.7                  | 11.7                    | 11.7                  |
| <b>Finderscope</b>                                                     | 5 x 20                  | 5 x 24                 | 5 x 24                | 5 x 24                | 5 x 24                  | 5 x 24                |
| <b>Hybrid Diagonal - .96" - 90°<br/>Uses .96" &amp; 1 ¼" Eyepieces</b> | Yes                     | Yes                    | Yes                   | Yes                   | Yes                     | Yes                   |
| <b>Eyepieces (in mm)</b>                                               | H 12.5<br>(50x)<br>.96" | H 20<br>(35x)<br>.96"  | H 20<br>(45x)<br>.96" | H 20<br>(35x)<br>.96" | SMA 25<br>(28x)<br>1 ¼" | H 20<br>(35x)<br>1 ¼" |
|                                                                        | H8<br>(78x)<br>.96"     | H12.5<br>(56x)<br>.96" | H8<br>(113x)<br>.96"  | SR6<br>(117x)<br>.96" | SMA 10<br>(70x)<br>1 ¼" | H 8<br>(88x)<br>1 ¼"  |
|                                                                        |                         | SR 6<br>(117x)<br>.96" |                       |                       |                         |                       |
| <b>Telescope Tube Color<br/>(W) Glossy White<br/>(B) Glossy Black</b>  | W                       | W                      | B                     | B                     | B                       | B                     |
| <b>2x Barlow Lens Included - .96"</b>                                  | No                      | No                     | Yes                   | Yes                   | No                      | No                    |
| <b>Tripod Type<br/>(W) Black Wood / (A) Aluminum</b>                   | W                       | W                      | W                     | W                     | W                       | A                     |

## CELESTRON ONE YEAR LIMITED WARRANTY

A. Celestron International (CI) warrants this telescope to be free from defects in materials and workmanship for one year. CI will repair or replace such product or part thereof which, upon inspection by CI is found to be defective in materials or workmanship. As a condition to the obligation of CI to repair or replace such product, the product must be returned to CI together with proof-of-purchase satisfactory to CI.

B. The proper Return Authorization Number must be obtained from CI in advance of return. Call Celestron at 310-328-9560 to receive the number to be displayed on the outside of your shipping container.

All returns must be accompanied by a written statement setting forth the name, address and daytime telephone number of the owner, together with a brief description of any claimed defects. Parts or product for which replacement is made shall become the property of CI.

**The customer shall be responsible for all costs of transportation and insurance, both to and from the factory of CI, and shall be required to prepay such costs.**

CI shall use reasonable effort to repair or replace any telescope covered by this limited one year warranty within thirty days of receipt. In the event repair or replacement shall require more than thirty days, CI shall notify the customer accordingly. CI reserves the right to replace any product which has been discontinued from its product line with a new product of comparable value and function.

**This warranty shall be void and of no force of effect in the event a covered product has been modified in design or function, or subject to abuse, misuse, mishandling or unauthorized repair. Further, product malfunction or deterioration due to normal wear is not covered by this warranty.**

CI DISCLAIMS ANY WARRANTIES, EXPRESS OR IMPLIED, WHETHER OF MERCHANTABILITY OF FITNESS FOR A PARTICULAR USE, EXCEPT AS EXPRESSLY SET FORTH HEREIN.

THE SOLE OBLIGATION OF CI UNDER THIS LIMITED ONE YEAR WARRANTY SHALL BE TO REPAIR OR REPLACE THE COVERED PRODUCT, IN ACCORDANCE WITH THE TERMS SET FORTH HEREIN. CI EXPRESSLY DISCLAIMS ANY LOST PROFITS, GENERAL, SPECIAL, INDIRECT OR CONSEQUENTIAL DAMAGES WHICH MAY RESULT FROM BREACH OF ANY WARRANTY, OR ARISING OUT OF THE USE OR INABILITY TO USE ANY CI PRODUCT. ANY WARRANTIES WHICH ARE IMPLIED AND WHICH CANNOT BE DISCLAIMED SHALL BE LIMITED IN DURATION TO A TERM OF ONE YEAR FROM THE DATE OF ORIGINAL PURCHASE.

Some states do not allow the exclusion or limitation of incidental or consequential damages or limitation on how long an implied warranty lasts, so the above limitations and exclusions may not apply to you.

This warranty gives you specific legal rights, and you may also have other rights which vary from state to state.

CI reserves the right to modify or discontinue, without prior notice to you, any model or style of telescope.

If warranty problems arise, or if you need assistance in using your telescope, contact:

Celestron International  
Customer Service Department  
2835 Columbia Street, Torrance, CA 90503 (U.S.A.)  
310-328-9560 / 310-212-5835 fax  
Monday - Friday 8AM-4PM PST

This warranty supersedes all other product warranties.

**NOTE:** This warranty is valid to U.S.A. and Canadian customers who have purchased this product from an authorized CI dealer in the U.S.A. or Canada. Warranty outside the U.S.A. and Canada is valid only to customers who purchased from a CI International Distributor or Authorized CI Dealer in the specific country. Please contact them for any warranty service.