

Quick Start Guide

English

Simple Steps

To Get Your AeroGarden³
and AeroGarden³ Elite
Up and Growing

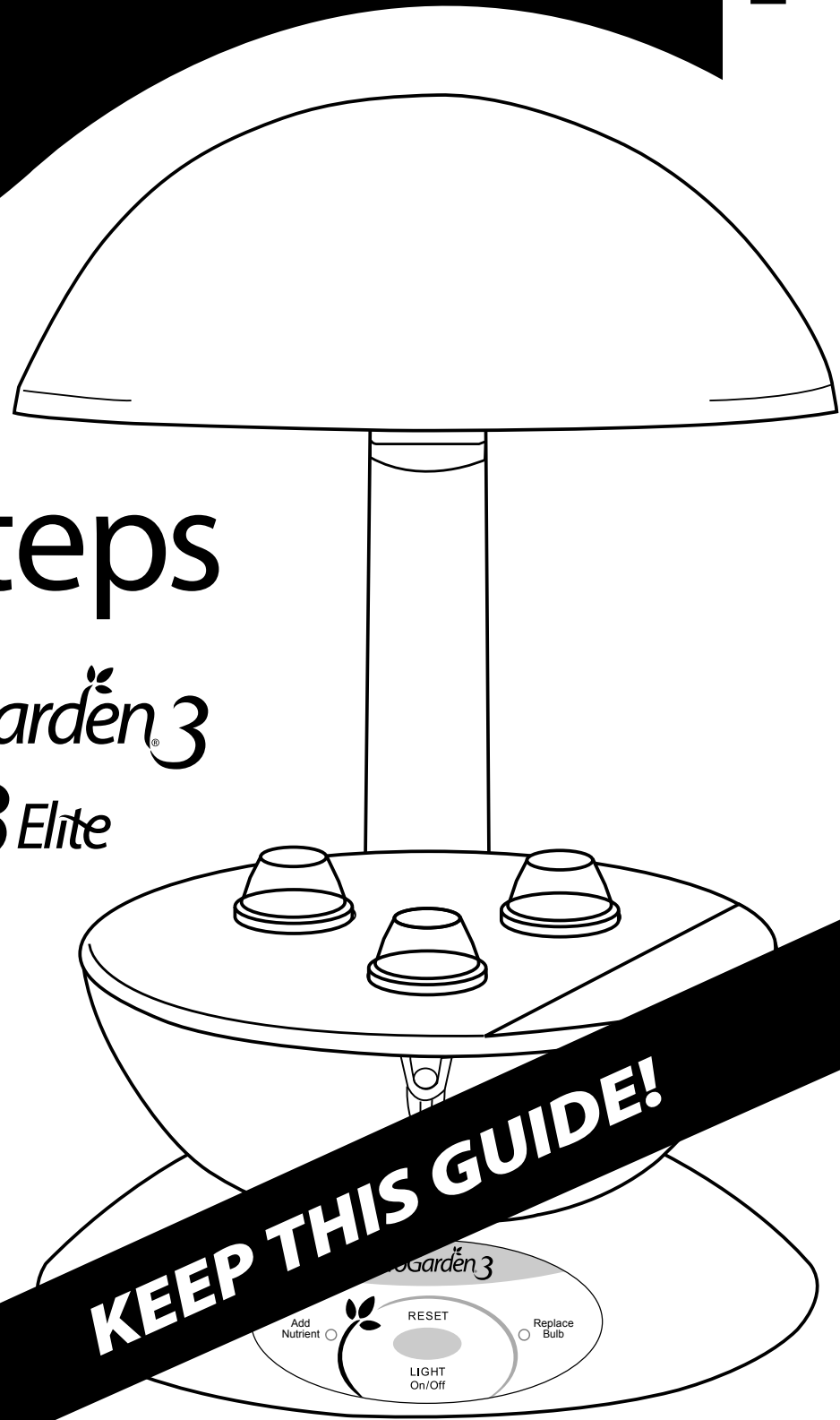

KEEP THIS GUIDE!

AeroGarden 3 Model #s – 100302-BLK; 100302-WHT;
100302-SLR; 100302-BSS; 100302-RED

Input Voltage: 120V, 60Hz, 0.45A

Date Code:

IMPORTANT SAFETY INSTRUCTIONS

(SAVE THESE INSTRUCTIONS)

When using this AeroGarden³ electrical furnishing, basic precautions should always be followed, including the following:

Read all instructions before using this AeroGarden furnishing.

1. To reduce the risk of electric shock, the AeroGarden has a specific plug. Do not change the plug in any way.

DANGER – to reduce risk of electric shock:

2. Always unplug AeroGarden from electrical outlet before cleaning or changing Grow Bulbs (light bulbs).

WARNING – to reduce risk of burns, fire, electric shock, or injury to persons:

3. Unplug AeroGarden from outlet before putting on or taking off parts.
4. Close supervision is necessary when AeroGarden is used by or near children, invalids, or disabled persons.
5. Use AeroGarden only for its intended use as described in instructions. Do not use attachments not recommended by manufacturer.
6. Never operate AeroGarden if it has a damaged cord or plug, if it is not working properly, if it has been dropped and damaged, or if it has been dropped in water. If any of these conditions occur/exist, contact www.aerogardensupport.com or your country's local distributor for instructions.
7. Keep cord away from heated surfaces.
8. Never operate furnishing with air openings blocked. Keep air openings free of lint, hair, and the like.
9. Never drop or insert any object into any electrical openings.
10. Do not use outdoors.
11. Do not operate where aerosol (spray) products are being used or where oxygen is being administered.
12. Do not touch moving parts or hot parts such as pumps, bulbs, reflective surfaces, and the like.
13. To disconnect, remove plug from outlet.
14. Do not place or submerge base, cord, plug, or lamp hood in water or other liquid to clean it.
15. Do not allow water to contact hot light bulbs.
16. Use only approved and supplied parts and accessories. Use only lamp model 100340 (N. America) or 200340 (Europe & Australia) Grow Bulbs with this AeroGarden model. Use of any other kind of accessory is not recommended. Replacement parts can be ordered from www.aerogardensupport.com or from your retailer.
17. Do not use AeroGarden for other than intended purpose.
18. This product is intended for household and residential use only. This product is not approved for commercial applications.
19. Read and follow all important notices on the AeroGarden and in the accompanying literature.
20. If supply cord is damaged, it must be replaced by manufacturer, its service agent, or similarly qualified technician in order to avoid a hazard.
21. Electrical wiring must be in accordance with local regulations.
22. This appliance is not intended for use by persons (including children) with reduced physical, sensory or mental capabilities, or lack of experience and knowledge, unless they have been given supervision or instruction concerning use of appliance by a person responsible for their safety.
23. Children should be supervised to ensure they do not play with the appliance.

SAVE THESE INSTRUCTIONS

1 Quick Start Assembly (No tools required)

A Unpack Your AeroGarden3

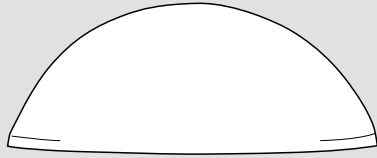

Lamp Hood
(front view)

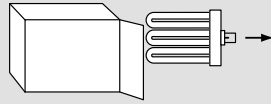

Grow Bulb (1)

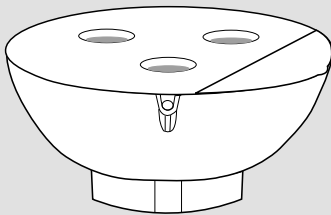

Bowl

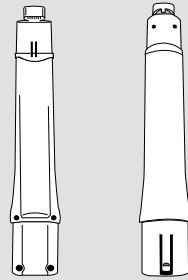

(front view) (back view)
Lamp Arm

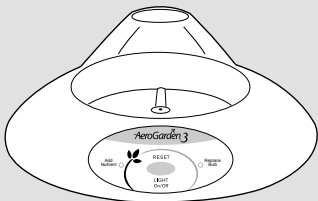

Base (front view)

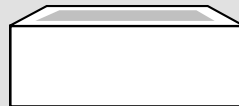

Seed Kit

C Insert Grow Bulb into Lamp Hood

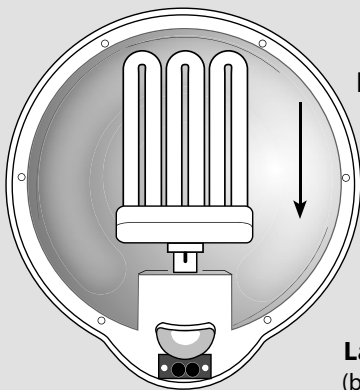

Push straight in.

Lamp Hood
(bottom view)

DO NOT TWIST BULB!

B Insert Lamp Arm into Base

Push
Lamp Arm
down until
you hear
a "click."

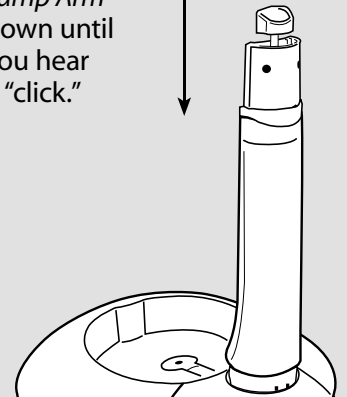

Lamp Arm
(back view)

Base
(back view)

D Plug Lamp Cord into Lamp Hood

Push *Lamp Cord* firmly into
socket in *Lamp Hood*.

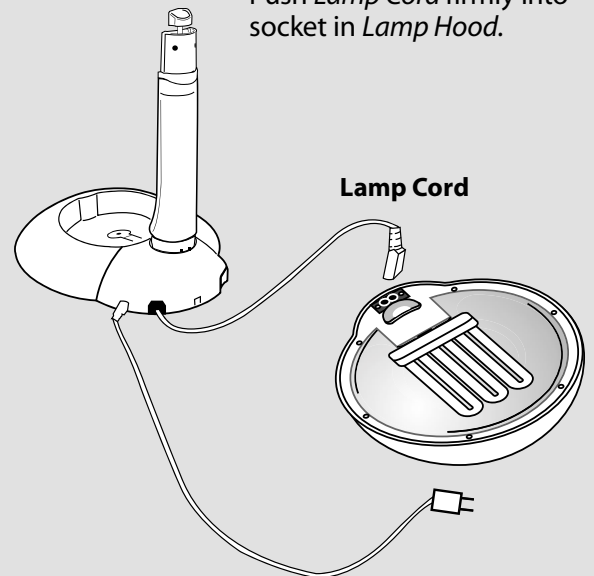

Lamp Cord

1 Quick Start Assembly (continued)

E Place Lamp Hood on Lamp Arm

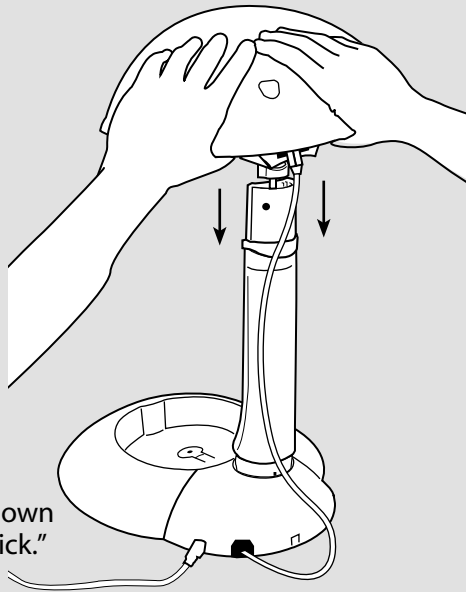

Center hands over *Lamp Arm* and push *Lamp Hood* down until you hear a "click."

(back view)

F Set Bowl into Base

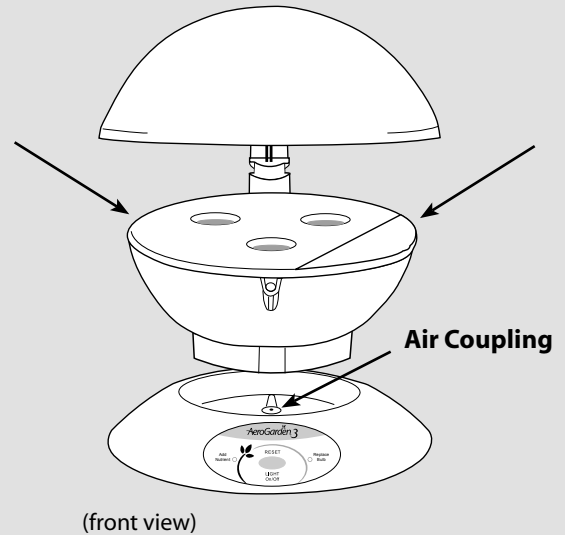

Air Coupling

(front view)

Check to be sure that *Bowl* is securely seated on *Air Coupling* in *Base*.

G Moving Your AeroGarden 3

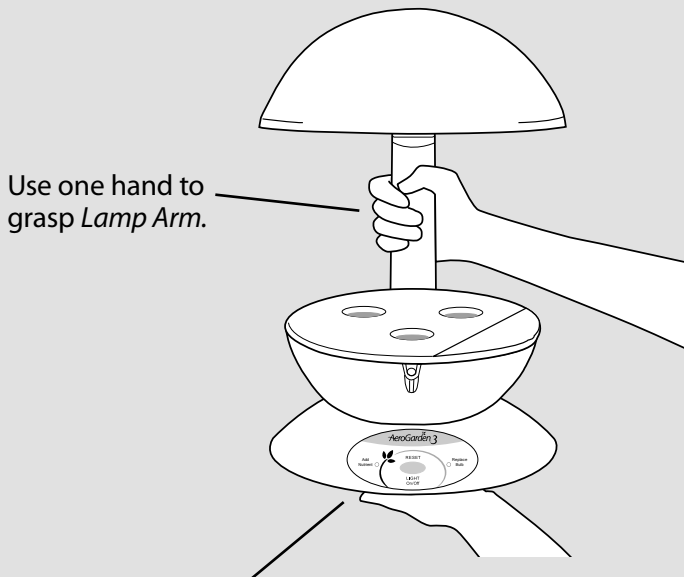

Use one hand to grasp *Lamp Arm*.

Gently slide AeroGarden 3 toward the surface edge and place other hand under *Base*.

NEED ADDITIONAL HELP?
For supplies and information, visit...
www.aerogardensupport.com

H Place Your Garden

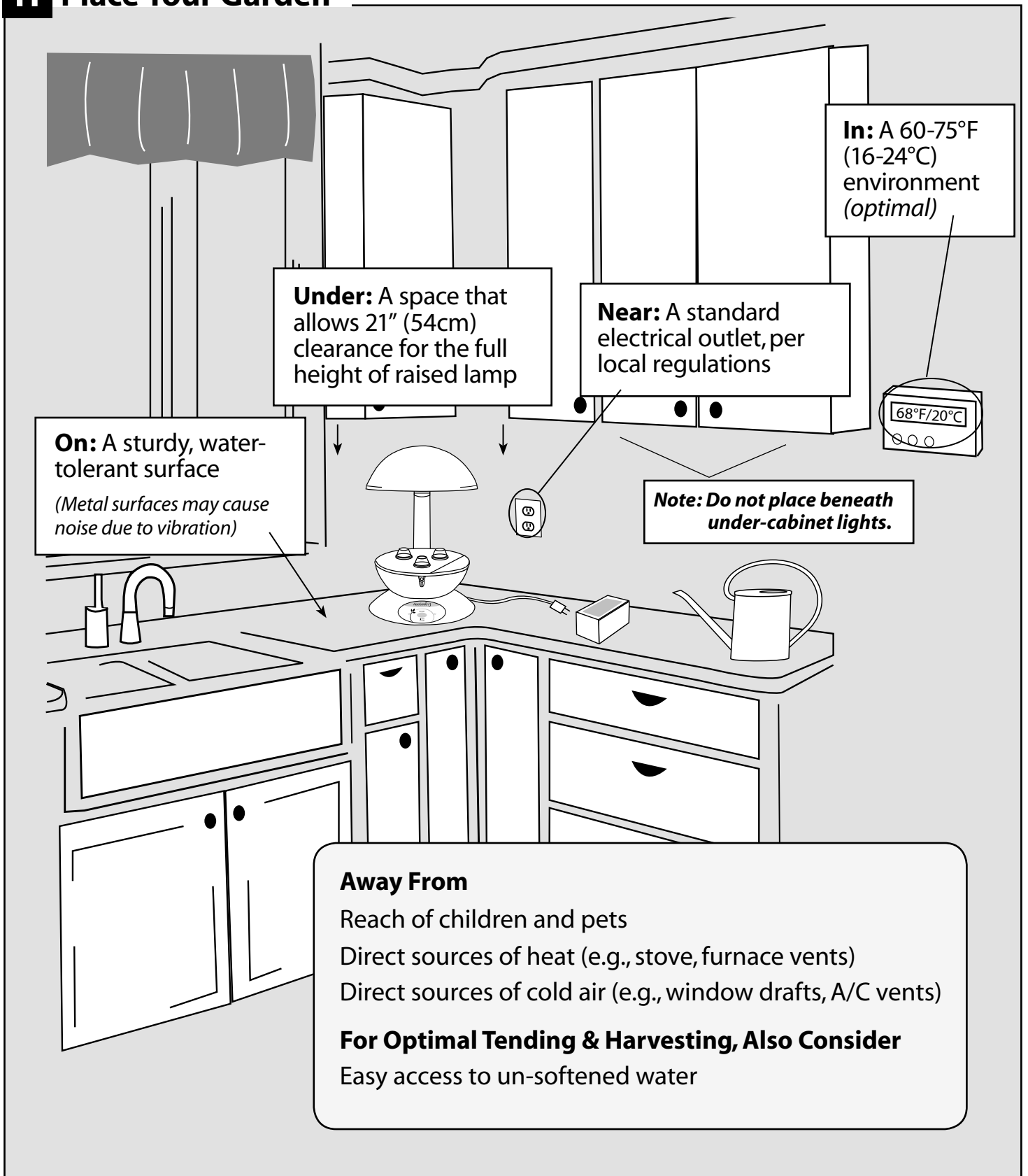

2 Planting Your Garden

A Add Water Using a Spouted Container

Fill to "Fill To Here"
(located below the View Door)

Use room temperature municipal tap, bottled or purified water. Do not use well or softened water.

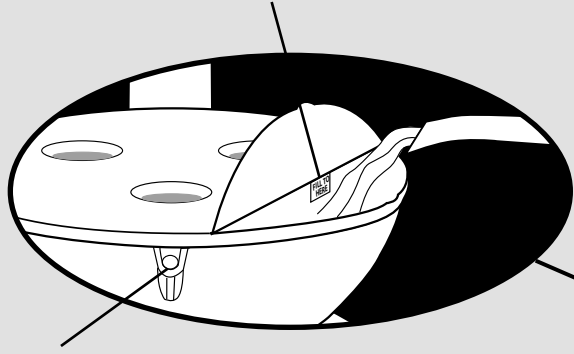

Water Level Indicator will turn red when water needs to be added.

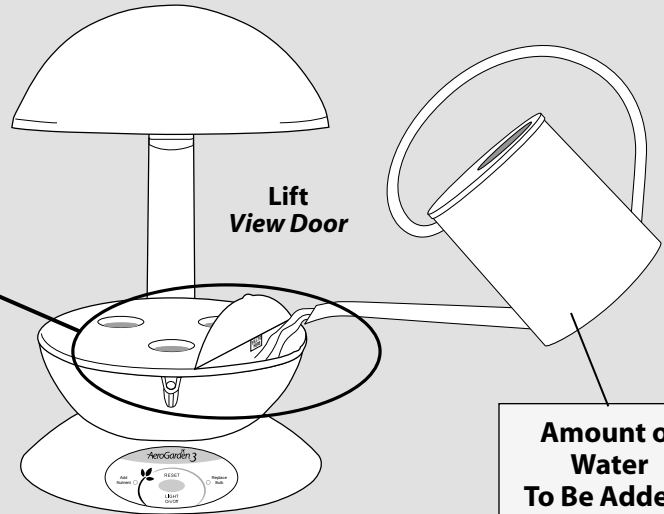

Amount of Water To Be Added:
1.5 quarts or
1.4 liters

When additional water is needed, water level indicator will be Red. Add water to raise level up to "Fill To Here" inside Bowl.
It is okay to add water up to "Fill To Here" before water level indicator turns red.

B Plant Your Garden

Plant your AeroGarden.

Check to see that:

- There is a *Seed/Plant Pod* or *Plant Spacer* in every *Grow Surface* opening.
- *Seed Pod Labels* are facing forward.

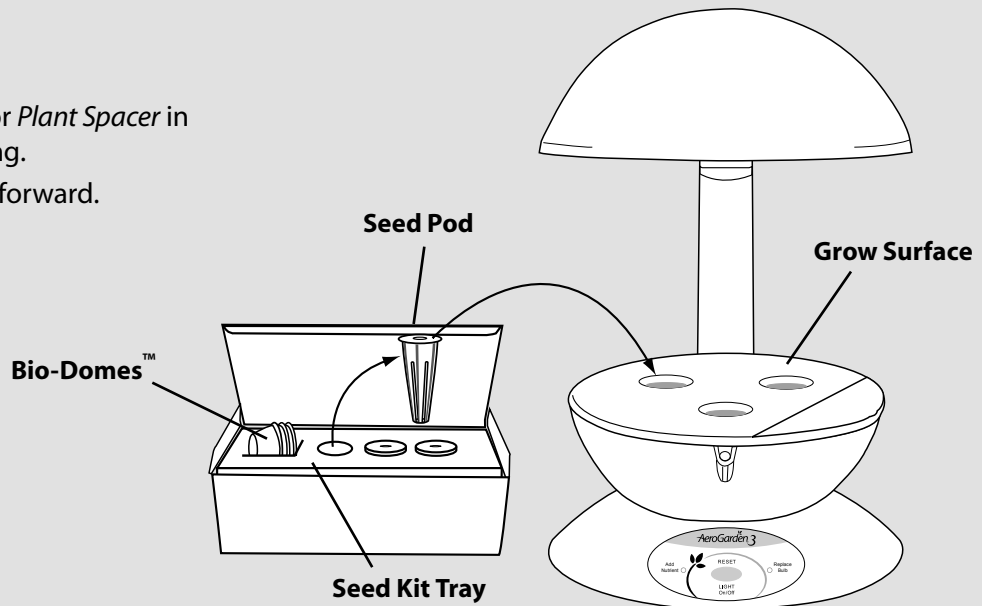

Special Seed Kit Option

Split a 6-pod Seed Kit and Grow Two Gardens!

Important guidelines to consider when splitting a 6-pod *Seed Kit*...

- Arrange *Seed Pods* where they receive enough light. See *Tending & Harvesting Guide* for plant-specific pruning & harvesting information.
- When planting – Use one *Starting Nutrient* and save the other one for your second Garden. Store unused nutrient in an airtight bag.
- All Other Feedings – Use one *Growing Nutrient*.
- Second Garden – When you have 8 nutrient tablets remaining – 1 *Starting Nutrient* and 7 *Growing Nutrients* – it is time to start your second Garden.

C Place Bio-Domes™ on Seed Pods

Place a *Bio-Dome* on each *Seed Pod*.

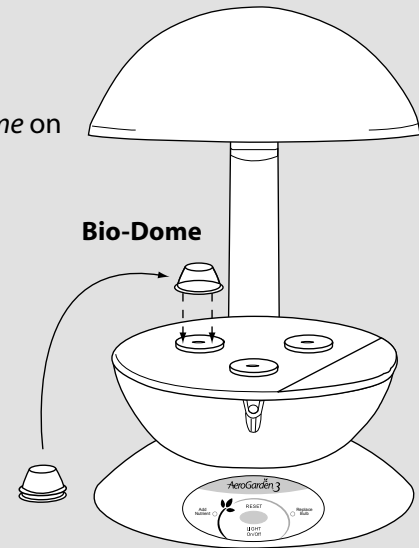

Note: Do not remove Bio-Domes until seeds have sprouted. NEVER REMOVE SEED POD LABELS.

D Add Starting Nutrient Tablet and Record Planting Date

Record Planting Date

Record the date your *Seed/Plant Kit* was planted on front cover of the *Tending & Harvesting Guide*.

See "**Add Nutrients**" (*Feed Garden - Basic Feeding*) on page 9 of this guide for additional feeding instructions.

***When splitting a 6-pod Seed Kit, be sure to use only 1 nutrient tablet when feeding your Garden (see "Special Seed Kit Option" above).**

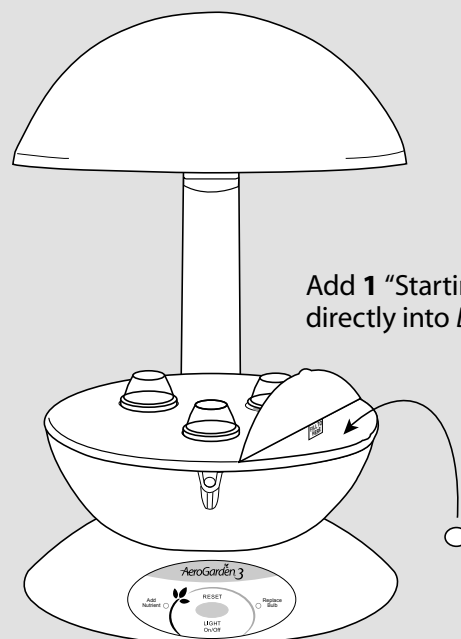

Add 1 "Starting Nutrient" directly into Bowl.

3 Starting Your Garden

A Plug Cord into Electrical Outlet

What will happen...

- 1** *Grow Bulb* will come on.
Look under *Lamp Hood* to check that bulb is lit.
If not, check to see if:
 - *Grow Bulb* is properly inserted in *Lamp Hood* (page 2, step 1C).
 - *Lamp Cord* is plugged into *Lamp Hood* (page 2, step 1D).
 - You are getting power through electrical outlet.
- 2** Air bubbles should be visible inside *Bowl*.
If not, check to see if:
 - *Bowl* is securely seated on *Air Coupling* in *Base* (see page 3, step 1F).
 - *Bowl* has water up to "Fill To Here."

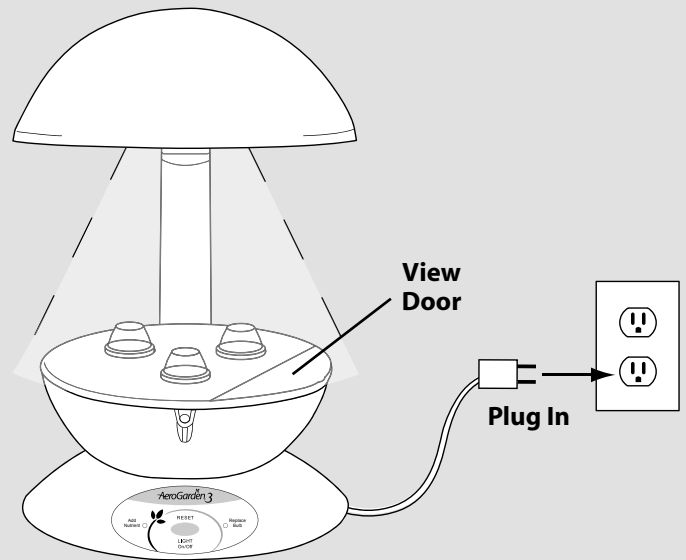

B Your Light Timer

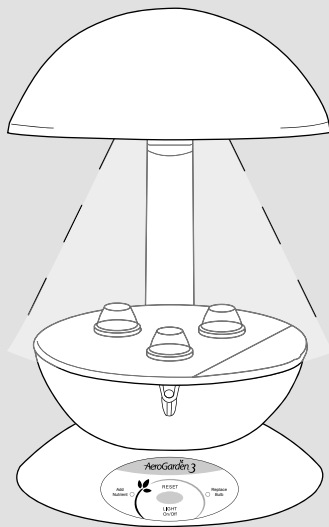

1 Your Light Timer is Set To Start Growing Your Plants...*Starting Now!*

2 If You Would Like to Change the Time of Day Your Light Goes On...

See Page 8.

- Your light will stay on for **17 hours** and will shut off for **7 hours**.
- Your light will come on every day at the time you plugged in your AeroGarden 3.

Personalize Your Light Timer (optional)

Your AeroGarden 3 has a built-in light timer that automatically provides your plants with the optimal amount of “sunlight” (17 hours) and “night” (7 hours).

As long as your plants get this amount of light, it does not matter when the light is turned off.* Many people find it convenient to have the light go on in the morning and off at night to match their own wake and sleep schedule.

***The exceptions to this are Flower & Vegetable plants. They require a daily dark period in order to produce flowers. If plants will receive any room light during the day (natural or artificial) we recommend setting your AeroGarden 3 light to be on during the day.**

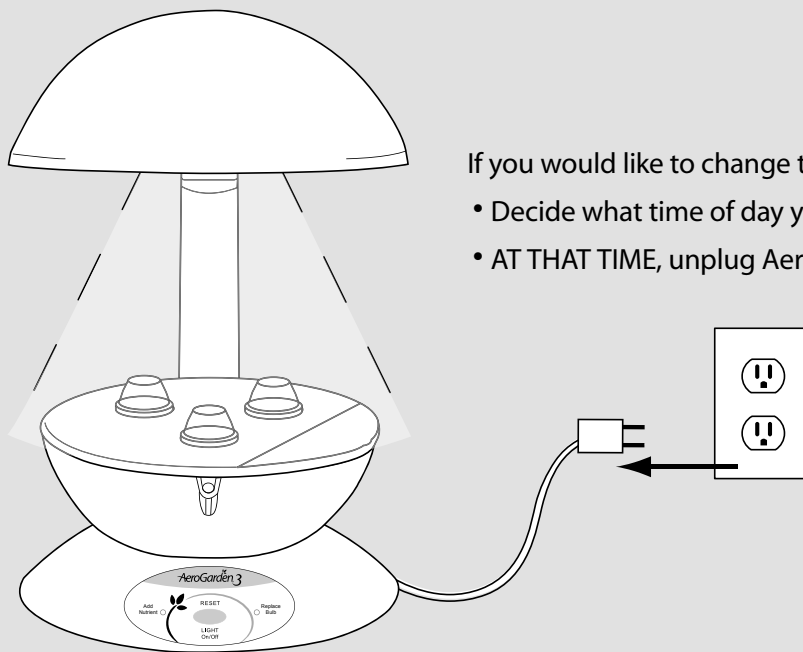

If you would like to change the time of day your light will go ON...

- Decide what time of day you want light to go ON.
- AT THAT TIME, unplug AeroGarden 3 and plug it back in.

Now, each day, your AeroGarden 3 light will automatically

- Turn on at the time you plugged in your AeroGarden 3
- Remain on for 17 hours
- Turn off for 7 hours

You can reset your timer as often as you want.

In case of power failure, AeroGarden 3 has a backup system that stores nutrient and grow bulb timer settings. You will need to manually reset the Off-On cycle for your light (see above) to return to your previously selected light setting.

Basic Reminders About Your AeroGarden

AeroGarden³ Control Panel

RESET

Use to reset "Add Nutrient" and "Replace Bulb" timers when each light illuminates.

LIGHT On/Off

Use to *occasionally* override built-in light timer. Once pushed, light will stay off/on until the next time built-in light timer is set to go on/off. This will not affect the timing of your light cycle, and *occasional* use of this feature will not harm your plants.

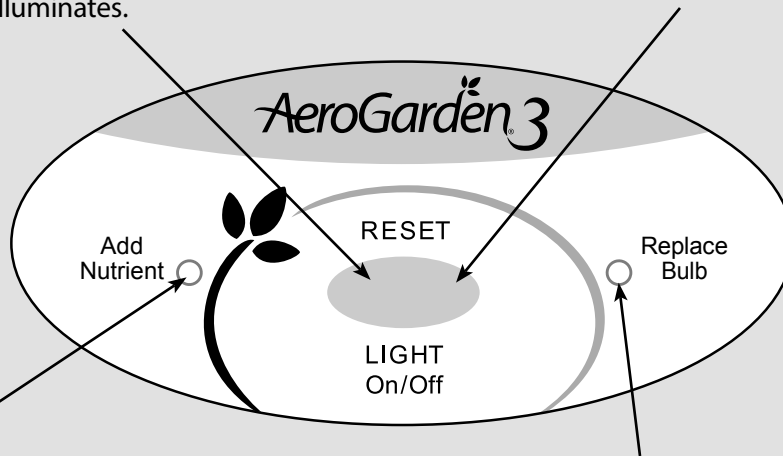

ADD NUTRIENT (Feed Garden - Basic Feeding)

When "Add Nutrient" light illuminates (every 2 weeks), add 1 nutrient tablet and fill Bowl with water up to "Fill To Here."

Press and hold "Reset" button until "Add Nutrient" light blinks (3 seconds). Release "Reset" button, then press and release again. "Add Nutrient" light will go off and timer is now reset.

REPLACE BULB*

When light illuminates (after 6 months of use), it is time to replace *Grow Bulb*. Order bulbs at www.aerogardensupport.com or from your retailer.

After replacing *Grow Bulb*, press and hold "Reset" button until "Replace Bulb" light blinks (3 seconds). Release "Reset" button, then press and release again. "Replace Bulb" light will go off and timer is now reset.

**See complete replacement instructions on page 11.*

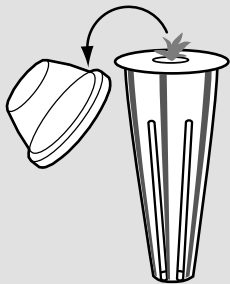

REMOVE BIO-DOMES

When plants appear through hole in *Seed Pod Label*, remove *Bio-Dome* and discard or recycle.

Note: Never remove Seed Pod Labels.

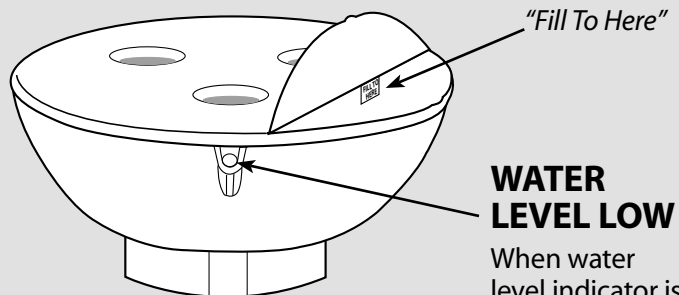

WATER LEVEL LOW

When water level indicator is RED, add water to "Fill To Here."

Basic Reminders About Your AeroGarden (continued)

Raise *Lamp Hood (Light)*

As plants grow to **1-2" from light**, raise *Lamp Hood* one notch at a time. Be sure *Lamp Arm* is in the lowest position when starting your AeroGarden 3.

- 1** Unplug AeroGarden 3 and remove *Bowl* from *Base*.
- 2** Hold *Lamp Arm* with one hand.
- 3** With other hand, support *Lamp Hood* and use thumb to push in *Locking Button*.
- 4** Release *Locking Button* while pulling up on *Lamp Arm*. *Locking Button* will automatically click into next notch.
- 5** Replace *Bowl* on *Base* and plug in AeroGarden 3.

Note: When lowering *Lamp Hood*, be sure to hold *Lamp Arm* to avoid crushing plants.

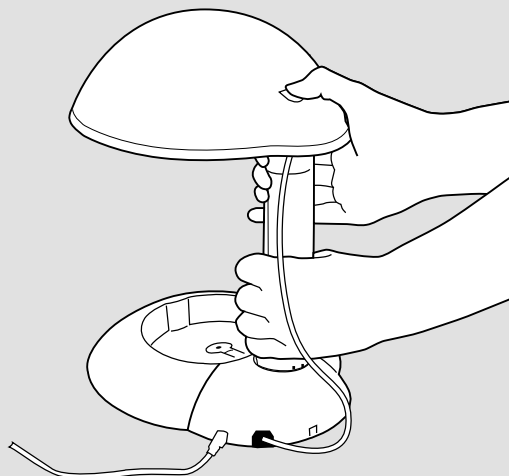
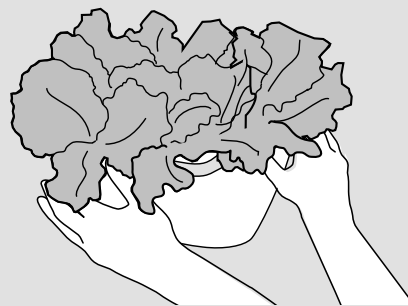

Basic Reminders About Your AeroGarden (continued)

Replace Grow Bulb – Order bulbs at www.aerogardensupport.com

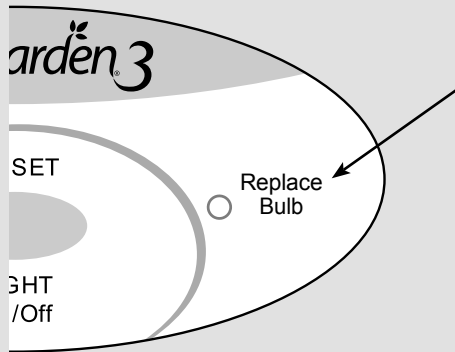

When "Replace Bulb" light on *Control Panel* illuminates after 6 months of use...

- Unplug AeroGarden 3 about the time your light comes on.
- Remove old *Grow Bulb* and carefully discard*.
IMPORTANT: To avoid burning, be sure Grow Bulb is cool before handling.
- Insert new *Grow Bulb* into *Lamp Hood*.
- Plug in AeroGarden 3 and press and hold "Reset" button until "Replace Bulb" light blinks (3 seconds). Release "Reset" button, then press and release again. "Replace Bulb" light will go off and timer is now reset.

Early *Grow Bulb* Replacement

If you replace *Grow Bulb* before "Replace Bulb" light illuminates, be sure to restart grow bulb timer as follows:

- Press and hold "Reset" button until "Replace Bulb" light blinks – about 9 seconds.
- Release "Reset" button.
- Quickly press and release "Reset" button. "Replace Bulb" light will blink once and grow bulb timer will be reset.

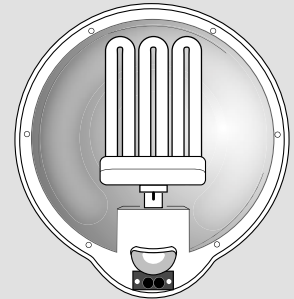

* Check with local recycling authorities for light bulb recycling availability in your area.

NEED ADDITIONAL HELP?
For supplies and information, visit...
www.aerogardensupport.com

Prepare For Your Next Garden

Cleaning Instructions for your AeroGarden

Use only water and mild soap when cleaning your AeroGarden (except when Sanitizing - Step 6). Do not use abrasive cleaners or run through the dishwasher.

When your garden has completed its growing cycle...

- 1** Unplug AeroGarden.
- 2** Carefully remove *Bowl* and *Grow Surface* from *Base* and bring to a sink. Set *Base* and *Lamp Hood* aside.
NEVER SUBMERSE BASE AND CONTROL PANEL IN WATER.
- 3** Remove *Grow Surface* from *Bowl* and place on counter near a sink.
- 4** Empty contents of *Bowl* in sink.
- 5** Remove *Seed Pods* and plants from *Grow Surface*.
 - Pull *Seed Pods* out of *Grow Surface* openings.
 - Throw away *Seed Pods* and plant debris (plant growth and roots). If you compost, plant debris can be composted.
- 6** Sanitize AeroGarden.*
 - Fill *Bowl* $\frac{3}{4}$ full with water.
 - Add $\frac{1}{8}$ cup (24ml) of chlorine bleach.
 - Let sit for 2 minutes.
 - Using sanitizing water, wipe *Grow Surface* with soft cloth or sponge. Scrub underside of *Grow Surface* with soft scrub brush to remove any tangled roots.
 - Thoroughly rinse *Grow Surface* with tap water and set aside.

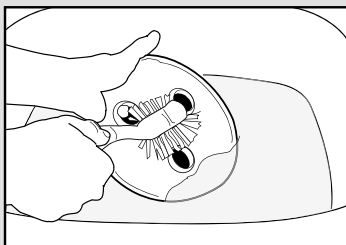
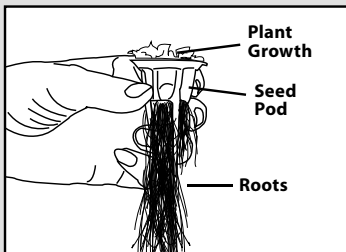

- Clean water level indicator *Prism* (located in *Bowl*), using a soft cloth.
 - Grasp rubber piece holding *Prism* in place and gently slide it up and out of *Bowl*.

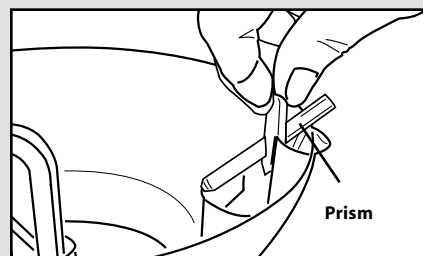

- Using tap water, wipe off *Prism* and rinse well.
 - Gently slide *Prism* back into housing in *Bowl*.
- 7** Rinse *Bowl* with tap water. Repeat.
 - 8** Towel dry *Bowl* and *Grow Surface* before putting them back together and setting them on *Base*.
 - 9** If *Grow Bulb* has been in use more than 6 months, it should be replaced at this time (see page 11).

Your AeroGarden is now ready for replanting.

*Gloves recommended.

Prepare For Your Next Garden (continued)

Replanting Your AeroGarden

If you have already grown a garden in your AeroGarden 3, please follow the instructions below to reset the nutrient timer:

- Press and hold "Reset" button until red "Add Nutrient" light blinks (about 6 seconds).
- Release "Reset" button.
- Quickly press and release "Reset" button. "Add Nutrient" light will blink once and nutrient timer will be reset.

NOTE: These steps do not reset grow bulb timer.

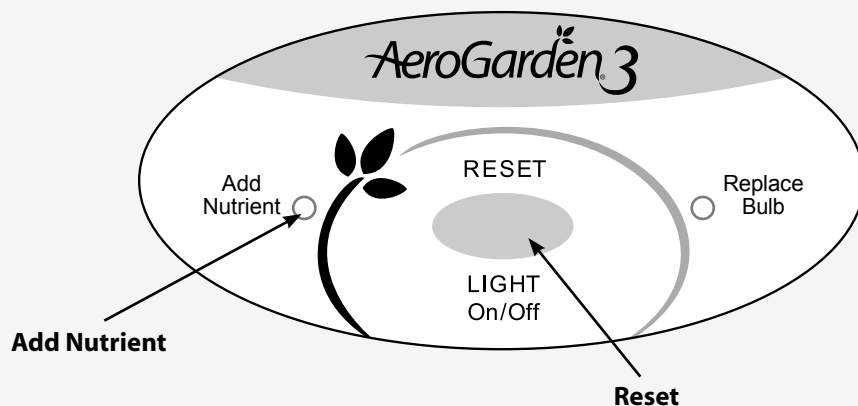

Remember to...

- Replace *Grow Bulb* after 6 months of use. Replacement bulbs can be ordered at www.aerogardensupport.com or from your retailer.
- Sanitize AeroGarden 3 before replanting (see page 12).
- Set your *Lamp Hood* to lowest position when starting a new garden.

! Bundle cord when furnishing is not in use.

Notes...

A large rectangular area with a light gray background and horizontal lines, intended for taking notes. The lines are evenly spaced and extend across the width of the area.

U.S. CAUTION – You are cautioned that any changes or modifications not expressly approved in this manual could void your authority to operate this equipment. **NOTE:** This equipment has been tested and found to comply with the limits for a Class B digital device, pursuant to Part 15 of the FCC Rules. These limits are designed to provide reasonable protection against harmful interference in a residential installation. This equipment generates, uses, and can radiate radio frequency energy and, if not installed and used in accordance with the instructions, may cause harmful interference to radio communications. However, there is no guarantee that interference will not occur in a particular installation. If this equipment does cause harmful interference to radio or television reception, which can be determined by turning the equipment off and on, the user is encouraged to try to correct the interference by one or more of the following measures: Reorient or relocate the receiving antenna; Increase the separation between the equipment and receiver; Connect the equipment into an outlet on a circuit different from that to which the receiver is connected; or, Consult the dealer or an experienced radio/TV technician for help.

To reduce the risk of electric shock, this furnishing has a polarized plug (one blade is wider than the other). This plug will fit in a polarized outlet only one way. If the plug does not fit fully in the outlet, reverse the plug. If it still does not fit, contact a qualified electrician to install the proper outlet. Do not change the plug in any way.

CAUTION: TO PREVENT ELECTRIC SHOCK, MATCH WIDE BLADE OF PLUG TO WIDE SLOT, FULLY INSERT.

ATTENTION: POUR ÉVITER UN CHOC ÉLECTRIQUE, PRÉSENTER LA LAME LARGE À LA FENTE LARGE ET POUSSER JUSQU'AU FOND.